

CANADA
DEPARTMENT OF MINES AND TECHNICAL SURVEYS
DOMINION OBSERVATORIES

PUBLICATIONS
OF THE
Dominion Observatory
OTTAWA

VOLUME XX No. 1

DOMINION OBSERVATORY ROCKBURST RESEARCH
1938 - 1945

BY

ERNEST A. HODGSON

EDMOND CLOUTIER, C.M.G., O.A., D.S.P.
QUEEN'S PRINTER AND CONTROLLER OF STATIONERY
OTTAWA, 1958

This document was produced
by scanning the original publication.

Ce document est le produit d'une
numérisation par balayage
de la publication originale.

PREFACE

A long series of rockburst studies, beginning late in 1938 and continuing through to October 31, 1945, was carried out at the request of Lake Shore Mines, Kirkland Lake, Ontario, by the Surveys and Engineering Branch of the (then) Department of Mines and Resources, Ottawa, operating through the Dominion Observatory. The direction of this research was assigned to Dr. E. A. Hodgson, then Chief of the Seismological Division of the Observatory.

Reports covering the progress of this work (22 in all) were prepared for limited distribution to serve as memoranda for Lake Shore Mines, the Department, and the Observatory. About fifty copies of each were mimeographed and bound, pamphlet style, and requests from various sources soon exhausted the supply. The continued demand for copies, and a growing opinion that a permanent record in printed form should be made available, has led to the decision that these reports should be edited and printed.

DOMINION OBSERVATORY ROCKBURST RESEARCH 1938-1945

by

Ernest A. Hodgson

Introduction

The first inquiry from Lake Shore Mines Limited was received on December 28, 1938. A severe rockburst had occurred the previous night at 10.50. C.E. McKnight, the company's Safety Director, inquired if any record had appeared on the Observatory seismographs to indicate that an earthquake had occurred at the time of the burst and, if so, whether it might have been the cause.

The vertical Benioff seismograph had produced a record lasting about three minutes that showed well-defined phases. It was quite evident that this was a record of the rockburst, and that there had been no general seismic activity that might have been the triggering cause of the burst.

The writer went to Kirkland Lake to consult with the mine officials and to obtain data regarding the rockburst. During the visit, E.W. Todd, Mine Superintendent, proposed that a seismograph station be established at the mine at company expense both as to initial cost and maintenance, but under direction of the Observatory. This proposal was accepted by the Department and steps were taken to secure instruments suitable for the conditions peculiar to the location. It took some months to decide on the best types and to have them manufactured, but the last items were received at Ottawa on October 31. After some weeks of testing, they were installed at the site selected by the writer, and the station came into operation on December 19, 1939.

Mr. Todd then proposed that rockburst research should be undertaken in the mine itself. This also received Departmental approval, and it was arranged that the general direction of the work should be assigned to the writer; a resident operator was secured in the person of Zack E. Gibbs, of San Marino, Cal.

In the meantime, Mr. Todd had resigned as Superintendent and Mr. A.E. Blomfield had been appointed to that office. The program continued to operate under the above conditions for about two years except that, from time to time, the company engaged part-time assistants for Gibbs. In June 1941, Frank Hallick was engaged as assistant on a full-time basis.

In 1942, the writer was assigned to full-time participation in the program, to be responsible for the work as a whole and to take over the underground studies. Hallick was to assist Gibbs in the maintenance of equipment and was to carry on the underground program in the writer's absence. This arrangement continued until the agreement with Lake Shore was terminated in 1945, when underground research was discontinued. Shortly thereafter,

the surface seismograph was transferred to Hallick's property at Kirkland Lake, a vault was constructed, and a full complement of instruments of modern type and high sensitivity was installed. A first-class seismological station has been operated there since that time.

Further research programs, utilizing rockbursts as energy sources of precisely known location, accurately timed by the Kirkland Lake seismographs, were carried out during the next three or four years by John H. Hodgson and his associates. The data so obtained have enabled him to draw up improved travel-time curves for short epicentral distances and to determine surface structure over the Canadian Shield. These results have been reported by him in detail in a series of papers (see bibliography).

The seismograph installation at Kirkland Lake is today one of the fully equipped and regularly operating stations of the network operated by the Seismological Division of the Dominion Observatory.

Summary Sketch of Original Rockburst Reports

Brief summaries of the original twenty-two reports are given below. Alphabetic designations (A to W inclusive, omitting I) are here employed in preference to numbers, with a view to simplifying the references to sub-headings in the complete, but revised, reports forming the body of this publication.

Report A

Dec. 27, 1938 to Jan. 18, 1940

The report first outlines the events leading up to the establishment of a seismograph station at Lake Shore Mines. Then follows a discussion of a correlation between a list of rockbursts (1938-1939) as furnished by Lake Shore with the corresponding seismograph records at Ottawa, Shawinigan Falls, and Seven Falls. Comparison is also given, with reproduction of the records obtained at Ottawa, of the registration of the rockburst of Dec. 27, 1938 with a quarry explosion of 45,000 lb. of dynamite near New Haven, Connecticut.

The report then deals with the selection of seismograph and radio equipment, the testing of equipment at Ottawa, the choice of site and preparation of recording room, observation routine, and analysis of records from Dec. 19, 1939 to Jan. 18, 1940.

The report notes Mr. Todd's proposal that an underground rockburst research program be established at Lake Shore Mines, and outlines a series of recommendations in that connection for the consideration of the company.

Report B

Jan. 18, 1940 to April 15, 1940

As those conducting the underground research knew little of mining in general, most of this report is devoted to a description of conditions at Lake Shore.

The last part of Report B describes the equipment and procedure during the first two months of the new underground program.

Report C

April 15, 1940 to Aug. 15, 1940

The report describes the construction and equipping of an electronics laboratory and machine shop at Lake Shore.

Improvements to the surface seismograph are noted as having been completed. A new mine (underground) seismograph, designed and constructed by Gibbs, is reported in operation.

The question of the possible difference in vibration frequency between bursts and blasts is suggested as a possible study, and plans to that end are outlined. Other lines of inquiry discussed are: supersonic vibrations (suggested by the writer in 1923 as an index of pressure and a means of prediction of earthquakes); strain gauges (one constructed by Gibbs is shown); temperature variation measurements; systematic correlation of mine and seismological data.

The collaboration between the Lake Shore research group and that of The International Nickel Company of Canada Limited, at Sudbury was reported in some detail.

Report D

This report deals solely with the program with the surface seismograph. It describes the steps taken to ensure, as nearly as possible, complete time coverage of burst and earthquake recording. It details the procedure for fixing responsibility for any lapse; this is considered important as a means of maintaining efficient operation.

Report E

Aug. 15, 1940 to April 15, 1941

The report deals with progress for the period indicated. Two chief items of interest are an account of experiments with a bore-hole closure gauge (microgauge) designed by

V.E. Hollinsworth of the Observatory staff and a record, through a burst, made by the strain gauge described in Report C.

The report also describes experiments with seismic survey equipment for the purpose of measuring vibration frequencies and velocities in the mine. These yielded few data, and none of much value in burst prediction.

The reason for the attempt to distinguish differences in vibration frequencies as between bursts and blasts was that if such differences could be shown to exist it might be possible to design a filter for the mine seismograph that would transmit bursts more strongly than blasts. Some slight frequency differences were indicated by the seismic survey equipment and by oscilloscope experiments, and a filter was designed and built by Gibbs for the mine seismograph, but the results were disappointing.

Report F

This report describes experiments with the microgauge carried out on typical Lake Shore mine rock at the Mines Branch, Ottawa.

Report G

The report covers the recording of the surface seismograph for 1941. In addition to the text describing the operational modifications, and the tabular matter as given in Report D, 1940, the following tables are included: larger rockbursts located and listed by Lake Shore Mines and rockbursts recorded on the surface seismograph.

Report H

Ten of the larger rockbursts recorded on the Benioff seismograph at Ottawa were studied as a group to determine the velocity of elastic waves and the structure of the earth's crust in the vicinity of Ottawa. Each of these bursts was precisely located in the Lake Shore mine. Two had been accurately timed at Kirkland Lake by the surface seismograph. This paper initiated the research in velocities and in surface structure carried out over several years by John Hodgson and his associates.

Report J

April 15, 1941 to June 30, 1942

Experiments in the mine with the microgauge are briefly reported. Modifications of the mine and surface seismograph are discussed. A severe rockburst that occurred on July 30, 1941 is dealt with at some length.

Steps had been taken to study supersonic vibrations as indicators of increasing rock pressure. Some equipment had been assembled and experiments had begun when the work of Dr. Leonard Obert, of the U.S. Bureau of Mines, was brought to the attention of the Kirkland Lake group. This report outlines the steps that led to the use of Obert recorders for the supersonic vibration studies.

Report K

July 1, 1942 to Dec. 31, 1942

The report reviews the difficulties overcome, outlines the underground program in progress, and describes the layout of test holes from which records were being obtained by means of Obert recorders. It includes a number of conclusions and recommendations.

The report concludes with data on test holes assigned to rockburst research (their location, history, condition, etc.).

Report L

Jan. 1, 1943 to March 31, 1943

A heavy rockburst on January 29, 1943 occurred in the section of the mine in which the recorders were operating. The effects of this burst and a discussion of the records are given, with photographic illustrations. This burst furnished the best evidence of the fact that subaudible snapping (designated 'microseisms') gives warning of a burst. It also shows the limitations in the application of the method in a mine such as Lake Shore.

An extensive list of recommendations shows the trend of the program, and a complete tabulation of data from all test holes is given for the period. A list of rockbursts registered in January includes 61 for which the observations are tabulated.

Report M

April 1, 1943 to Jan. 31, 1944

The first part of this report is devoted to a revision of theories and deductions and to a series of recommendations. The further development of the research program is detailed. The routine of calibrating the equipment is described, the listening procedure outlined and the data obtained during the period are given in detail. The rockbursts occurring from April 1943 to January 1944 inclusive are listed.

Report N

A short bibliography of rockburst literature listing 58 items. It serves as the source of most of the publications listed in the bibliography at the end of this publication. The additional items cover only the later research program on rockbursts carried out by the Dominion Observatory through its Division of Seismology.

Report O

Feb. 1944 to June 1945

After reporting progress on the regular underground program, this report outlines a new intensive program carried out in a section of the mine considered particularly liable to bursts. Seventeen holes were spaced at 30-ft. intervals on each side of a section of drift, the holes being staggered so that there was one every 15 ft. Recordings were taken from nine holes in a planned order, each recording lasting a little over 5 minutes. One hole of the nine, designated as a monitoring comparison, recorded three times in the hour. The recording was carried on for 3 hours in the afternoon when mining activity was at a minimum, and for 3 hours in the 'graveyard' shift, when no mining was in progress. The strips of recorder tape were mounted in sequence and photographed each day. These photographs, with brief notes calling attention to features of interest, were published as reports P to V.

Report W

This report covers experiments of the College Park, Md., laboratory of the United States Bureau of Mines. Specimens of Lake Shore rock were cut into small samples and subjected to increasing pressure in a hydraulic press. A geophone unit attached to the specimen under test recorded on a regular Obert instrument.

The object of the experiments was to test the validity of the contention that high pressures on a rock specimen produce high-pitched, subaudible vibrations (microseismims), and that these microseismims offer a means of determining when the rock under pressure has reached the limit of its strength and is about to burst.

The experiments were undertaken at the request of the National Research Council of Canada, and were carried out by three Canadians (Hodgson, seismologist; Langford, mining engineer; Bailey, electronics engineer).

Report A

Surface Seismograph Installation

1939

A-1 Correlation of Rockburst and the Ottawa Seismograms

On December 27, 1938, at about 10:50 p.m., E.S.T., a severe rockburst occurred at Lake Shore Mines. It was decided that the writer should go to Kirkland Lake to learn what he could of the burst. While there, he made various attempts to determine the exact time of the burst, but was unable to do so.

The burst was slightly above the 2700-ft. level. About 160 ft. of drift was affected, 98 ft. being closed solidly. Broken rock resulting from a burst is coated with a fine white dust, indicating that part of the rock disintegrated at the instant of release from strain. Rock broken by blasting does not exhibit this dust coating.

Examination of the seismograms at Ottawa established the fact that no earthquake occurred at the time of the burst, and it must therefore be considered as being the sole cause of the record. The mechanism of the release of energy is exactly the same whether the storage of that energy was due to natural causes or to the mining operations. Moreover, the energy release in a severe burst is very great.

Lake Shore Mines furnished a list of the larger rockbursts that had occurred up to that of December 27, 1938. On checking these at Ottawa, the following report was sent to mine officials under date of January 11, 1939.

"You will note that the records of two instruments were checked -- the short-period vertical Benioff at Ottawa and the short-period horizontal Wood-Anderson at Shawinigan Falls. The Ottawa Benioff was not in operation previous to April 5, 1937. It was then run experimentally for a couple of months or so, the recording being sometimes interrupted to permit changes in the set-up. For this reason we have no records to check bursts numbered 1-5. The instrument was temporarily out of commission for Nos. 16 and 17 (July 19 and September 9, 1938).

"The net result of the check-up is that the only record obtained at Ottawa is that of December 27 last. Those recorded at Shawinigan Falls are those of January 5, 1937, July 19, 1938, and December 27, 1938. Presumably, the first two of these would have recorded at Ottawa had the Benioff been in operation at the time."

Requests for seismograms were sent out to those seismograph stations within a radius of 600 miles of Kirkland Lake at which short-period seismographs were operating during the period covered by the tabulation of rockbursts. None of these bursts were recorded except that for December 27, 1938, which was just visible as a trace on the Weston, Mass., short-period Benioff record. The arcual (computed) distance from Kirkland Lake to Weston is 580 miles.

Subsequent to December 1938 and through 1939, the larger rockbursts occurring at Lake Shore were reported to Ottawa (see list p.). Eight bursts were reported from Lake Shore Mines and recorded with phase differentiation at Ottawa.

A-2 Initial Discussions and Correspondence

In January 1939, E.W. Todd, of Lake Shore Mines, discussed with the writer the possibility of establishing a seismograph station at Kirkland Lake. The company undertook to finance the establishment of such a station and to purchase the equipment, also to provide quarters, electricity, water services, and daily attendance on condition that the Observatory would supervise the selection of instruments and their installation, would supply photographic paper and developer, and would provide such technical assistance as might be required. The Observatory was also to analyse the records and issue regular reports to the company; the seismograms were to become the property of the Observatory.

The Observatory stressed the point that the establishment of a single seismograph at Kirkland Lake would be of considerable scientific value but that, so far as rockburst prediction was concerned, the instrument could only be expected to record their times of occurrence and their relative intensities. This is specifically set forth in a letter from Mr. Stewart to Mr. Todd under date of January 11, 1939, which at the same time tabulated the various requirements that would have to be met by a seismograph operating under the exacting conditions obtaining at Kirkland Lake. The unusual amount of ground disturbance due to traffic and heavy machinery, together with the presence of power transmission lines, made it problematical whether any type of seismograph then available could be used to advantage. It was quite possible that if the sensitivity were made high enough to record the bursts, the local surface disturbance would vitiate the record. It was also evident that some means of readily adjusting the sensitivity would be essential.

In a letter to Mr. Stewart, dated January 14, Mr. Todd confirmed the verbal agreement and acknowledged the limitations outlined from Ottawa.

A-3 Selection of Seismograph and Radio Equipment

Correspondence was immediately initiated by the Observatory with those seismologists best qualified by experience to advise on the selection of an instrument; and the results were submitted to Mr. Todd on April 14. In his reply, dated April 17, 1939, Mr. Todd guaranteed to meet the cost of the equipment and of installation and maintenance.

Under date of April 25, the necessary authorization was given by the Department. A proposal was made by Mr. Stewart, under date of March 6, that the company should reimburse the Department for the cost of the seismograph and radio equipment, the whole to become and remain the property of the Department, and to be left at Lake Shore as long as required. The authority from the Department included a guarantee to leave the instruments at the mine 'at least 10 years, or longer if conditions so require'. This arrangement was agreed to by Mr. Todd in a letter dated May 8, 1939.

The equipment ordered consisted of the following:

- 1 Special Rockburst Recorder
- 1 Type SE-400-P Vibration Detector
- 1 Special Recording Camera from the Heiland Research Corporation.
- and
- 1 National Standard HRO Receiver (2.5 volt)
- 4 Sets of Coils 1.7 m.c. to 30 m.c.
- 1 Speaker for above Receiver
- 1 Power Supply Unit (110 v., 25 cycles)
- 1 Set of Coils 100 k.c. to 200 k.c.
- 2 Sets of Coils 900 k.c. to 2,000 k.c. from the Canadian Marconi Company.

The initial radio equipment was received at Ottawa about July 8, 1939. It was tested under various conditions and by different operators throughout the summer and fall. The seismograph was received at the Observatory on October 31, 1939.

A-4 Testing and Installation of Equipment

On testing the equipment at Ottawa, it was found that certain alterations and adjustments to the seismograph were necessary, and this delayed the installation at Lake Shore. However, the instruments were placed in operation on December 19.

The site for the station, chosen by the writer, was below the gymnasium of the building used as living quarters by Lake Shore staff members: its relation to the mine is shown in Figure 5. An anteroom 5' x 7' housed the radio and time-recording equipment, and also acted as a light trap for the adjoining seismograph room. The latter (11' x 12', less a corner 3' x 5' -- Figure 6) housed the seismograph and a developing bench, with the necessary cupboard space. The emplacement of the seismograph is shown in Figure 7.

A-5 Observational Routine

On arrival at the station, usually about 12:30 p.m., the operator tuned in Station NAA (Arlington), adjusting the relay to give as clear reception as possible, and closing the knife switch on the relay at about 12:55, so that the beats up to and including the long note at 1 p.m. were recorded. If the work had to be done at another time of day, the operator tried

to pick up the Observatory continuous signals (CHU): if these were not sharp enough to operate the relay, the signals were recorded by means of a telegraph key.

The record sheet was then changed, and the mechanism for driving the drum wound up. The sheet removed was developed, and the time breaks and other data entered in soft pencil; the completed sheet was then forwarded to Ottawa.

A-6 Further Rockburst Research Proposed

When the seismograph installation had been completed at Lake Shore, Mr. Todd suggested the possibility of further research on rockbursts. It seemed possible that a rockburst in any given section of the mine might be predicted, and the following possibilities were suggested:

- (a) If a sensitive seismometer were installed in the area under observation and were to record continuously, the chronological pattern of the heavy rumbling noises preceding a burst might be learned by experience and serve as a basis for predicting later bursts.
- (b) If the pick-up used were a sensitive microphone with its amplifier provided with a wave trap to cut out the rumbling, it was believed that high-pitch (perhaps ultrasonic) crackling might be found to precede bursts, in a chronological pattern that would have to be learned by experience.
- (c) The velocity of sound in rock increases with the pressure, and it is possible to measure such velocities over short distances with the necessary precision to indicate changes in velocity due to increasing pressure. The velocity at bursting conditions has been found experimentally in the laboratory. If velocities were frequently measured at the suspected point in the mine, the approach to critical conditions could be observed.
- (d) It is possible that continuous registration of temperature creep, by means of thermo-couples and amplifiers, might yield some indication, by its time pattern, of the approach of a burst.
- (e) The use of strain meters to produce continuous records of the displacements in suspected areas might prove worth while.
- (f) Reference marks could be installed at known faults in the mine. The separation of these could be measured at regular intervals, and would serve to indicate the activity along these faults.

Mr. Todd proposed that such research be carried on under the supervision of the writer, who was asked to suggest the name of a qualified man who might be employed by the

company to take charge of the actual operations at Kirkland Lake. He suggested Zack E. Gibbs, of San Marino, Cal., who was engaged as of January 27, 1940.

The project was approved by the Department on January 12, 1940, and steps were taken to plan such studies as were possible with the limited equipment immediately available. Most of this was designed and built at the Observatory.

Appendix Section

A-7 Location Data for Rockburst of December 27, 1938

1. Geographical coordinates of centre point of No. 3 Shaft:
 N. 48°08'56.95" W. 80°02'42.72"
 2. Azimuth and Distance from above point to centre of burst:
 N. 80°58'36" E. Distance: 213.8 ft.
 3. Elevation of No. 3 Shaft Collar = 1051.0 ft. (Sea-level datum).
 4. Distance below collar of No. 3 Shaft to point nearest the centre of the burst:
 2,683 ft.
- The readings for the Ottawa record of the rockburst are as follows:
- | | |
|---------------------------|-----------------------|
| H = 11:49.9 p.m., E.S.T. | S* = 11:51:50 |
| P _n = 11:50:52 | F = 11:53.5 |
| P* = 11:51:01 | △ = 415 km. (258 mi.) |
| S _n = 11:51:37 | |

These readings are based on Joliat's Tables for nearby earthquakes. These evidently need revision, for conditions between Kirkland Lake and Ottawa at any rate, for the computed arcual distance between these places is 279 miles.

A-8 Correlation of larger rockbursts at Lake Shore Mines with seismograms at Ottawa and Shawinigan Falls March 20, 1936, to December 27, 1938 Short-period, vertical Benioff, Ottawa, Ont.

- | | | |
|---------------|-----------|----------------------|
| 1. Mar. 20'36 | 3:25 p.m. | No records available |
| 2. Dec. 3'36 | 9:45 a.m. | No records available |
| 3. Dec. 16'36 | 3:25 p.m. | No records available |
| 4. Jan. 5'37 | 7:30 p.m. | No records available |
| 5. Apr. 27'37 | 2:40 p.m. | No records available |
| 6. June 13'37 | 6:30 a.m. | No trace found |

DOMINION OBSERVATORY

| | | |
|----------------|------------|--|
| 7. June 16'37 | 11:00 p.m. | Questionable trace at 9:59:45 (might be the burst if K-L time as given were Daylight Saving, as is probable) |
| 8. Aug. 14'37 | 10:20 p.m. | No time breaks on the record Various faint traces, but not definite at 9:20 [±] (or 10:20 [±]) |
| 9. Sept. 4'37 | 11:20 p.m. | No time breaks on the record. Various faint traces but not definite at 10:20 [±] (or 11:20 [±]) |
| 10. Nov. 26'37 | 10:15 p.m. | Possible faint traces at 10:15 but clock beats and heavy microseisms prevent certainty |
| 11. Dec. 24'37 | 5:00 a.m. | Microseisms and clock beats; no certainty of traces. |
| 12. Apr. 6'38 | 3:15 a.m. | Very heavy microseisms; no trace |
| 13. May 11'38 | 9:15 p.m. | Very heavy microseisms; no trace |
| 14. May 20'38 | 12:45 p.m. | Microseisms present; no trace at 11:45 a.m. [±] or 12:45 p.m. [±] 11:45 p.m. [±] or 12:45 a.m. [±] (May 21) but sharp "local" type at 1:45:22 p.m., May 20. However, two others much the same at 11:03:23 a.m. May 20 and at 3:03 p.m., May 20 |
| 15. July 4'38 | 3:30 p.m. | Microseisms present; no trace |
| 16. July 19'38 | 7:19 a.m. | No record available |
| 17. Sept. 9'38 | 6:40 a.m. | No record available |
| 18. Oct. 2'38 | 2:30 a.m. | Small microseisms; no trace |
| 19. Oct. 14'38 | 2:40 a.m. | Small microseisms; no trace |
| 20. Nov. 17'38 | 9:10 a.m. | Gear trouble and microseisms; no trace |
| 21. Dec. 27'38 | 11:50 p.m. | Well recorded, begins at 11:50:52 and continues for a little more than two minutes |

Short-period, Vertical Wood-Anderson, Shawinigan Falls, Que.

Of the 21 rockbursts reported above no trace was found at Shawinigan Falls, except for the following:

| | | |
|----------------|------------|---|
| 4. Jan. 5'37 | 7:30 p.m. | Fairly good record beginning at 7:30:17 and continuing for about one minute |
| 16. July 19'38 | 7:19 a.m. | Trace at 7:28 a.m., continuing slightly less than a minute; not legible |
| 18. Oct. 2'38 | 2:30 a.m. | Faint traces, possibly due to the burst; quite illegible |
| 21. Dec. 27'38 | 11:50 p.m. | Trace at 11:52:09, continuing for about a minute; illegible |

All records to which Daylight Saving time might have applied in the report from the mine were examined also an hour earlier than the time given. No traces other than those listed above were found.

A-9 Rockbursts at Lake Shore Mines, Dec. 28'38 to Dec. 18'39

The first section of each entry below gives the report as received from Lake Shore Mines. The times given in this first section are approximate only. The latter section shows the nature of the reception at Ottawa, with full readings of those tremors which were registered.

| | | |
|-----------|-----------|--|
| 1. Feb. 7 | 1:25 p.m. | Felt at Lake Shore, but no damage in Lake Shore Mines and none reported from adjoining properties. |
|-----------|-----------|--|

Ottawa readings:

H = 1:25:26.6

eP_n? = 1:26:25

e = 1:27:02

eS_n? = 1:27:10

e = 1:27:15.5

e = 1:27:23

F = 1:27.8

△ = 415 km. (258 mi.)

| | | |
|------------|-----------|-------------------|
| 2. Feb. 19 | 4:02 p.m. | Medium intensity. |
|------------|-----------|-------------------|

Ottawa:

A single faint trace 4:06:25 to 4:07:05; may be due to other causes

3. Mar. 11 8:14 p.m. Very heavy, disturbed large section of the mine covering a vertical distance of 500 ft. and a horizontal distance of 400 ft.; centred at 686 ft. S 80° 14' E from the centre of No. 3 Shaft at a vertical depth of between 3450 ft. and 3575 ft.

Ottawa readings:

H = 8:14:11.6

 $P_n = 8:15:10$

P* = 8:15:18

 $S_n = 8:15:55$

S* = 8:16:06.5

F = 8:17

 $\triangle = 415 \text{ km. (258 mi.)}$

4. Mar. 26 4:50 a.m. Heavy burst; location of apparent centre from No. 3 Shaft is 604 ft. S 26° 50' W.

Ottawa readings:

Ottawa records show light traces only from 5:08:01

to 5:10.5; may be due to other causes

5. Mar. 28 1:07 p.m. Location of apparent centre from No. 3 Shaft is 936 ft. S 86° 00' E.

Ottawa readings:

H = 1:09.0 p.m.

i(P*) = 1:10:40

i(S_n) = 1:11:17

i(S*) = 1:11:30

i = 1:11:33.5

F = 1:11.8

 $\triangle = 445 \text{ km. (276 mi.)}$

6. Apr. 30 4:03 p.m. Severe rocking motion; some slight trace in mine but not sufficient to account for surface tremors; no damage.

Ottawa and Shawinigan Falls got no trace

7. Aug. 31 2:50 a.m.
3:00 a.m.
3:04 a.m. Three tremors, the first of medium intensity, the second heavy, and the third medium. These were followed by more tremors. Approximate centre of disturbance from No. 3 Shaft was 600 ft. in a direction S 80° E at depth 3575 ft.

Ottawa readings:

H = 2:51:59 a.m.

 $P_n = 2:52:57$

P* = 2:53:05

 $S_n = 2:53:42$

i = 2:53:55

i = 2:53:58

F = 2:55

 $\triangle = 415 \text{ km. (258 mi.)}$

| | |
|--------------------------|-----------------------|
| H = 3:02:00 a.m. | i = 3:03:58 |
| P _n = 3:02:59 | i = 3:04:00 |
| P* = 3:03:07 | F = 3:06 |
| i = 3:03:50 | △ = 415 km. (258 mi.) |

There was no trace of the third disturbance, but the second shock was recorded as more severe than the first.

8. Sept. 2 2:40 a.m. These shocks were each of medium intensity; they originated at about the same locality as those of Aug. 31, but approximately 300 ft. deeper.

Ottawa readings:

| | |
|--------------------------|-----------------------|
| H = 1:44:55 p.m. | i = 1:46:52 |
| P _n = 1:45:53 | F = 1:48 |
| i = 1:46:02 | △ = 415 km. (258 mi.) |
| S _n = 1:46:38 | |

No trace of the first of the above bursts was found on the records at Ottawa

9. Sept. 19 10:45 p.m. Each of these bursts was of heavy intensity; they were followed by some fifteen smaller bursts, not sufficiently severe to register at Ottawa. The bursts occurred between the 1400 and 2500 ft. levels.

Ottawa readings:

| | |
|------------------------------|----------------------------|
| H = 10:54:44.5 p.m. | iS* = 10:56:46 |
| iP _n = 10:55:46 | iS _g = 10:57:00 |
| iP* = 10:55:55 | F = 11:07 |
| iS _n = 10:56:33.5 | △ = 440 km. (275 mi.) |
| i = 11:08:10 | i = 11:09:0 |
| i = 11:08:47 | F = 11:11 |

It is just possible that an earthquake, represented by the first set of readings above, occurred somewhat north of Kirkland Lake, and that the rockbursts were set off at the mine as a consequence of the disturbance.

All times given in the section just completed (A-9) are given in Eastern Standard Time.

A-10 Explanation of index abbreviations in Table 1

1. Dates are recorded as: Day : Month
e.g. 19 : 12 indicates December 19.

2. Value of the time signal is given by a number in the scale 0 to 3, with the following signification:

| | |
|---------------|------------------------|
| 3 = excellent | 1 = doubtful |
| 2 = fair | 0 = lacking altogether |
3. Time correction: + means clock slow
- means clock fast.
4. The amount of time correction is given in seconds and is followed by the hour (on the 24-hour system beginning at midnight) nearest to which the correction was obtained. It is not underlined if the correction was obtained on the first day of the record. If it was obtained on the second day it is underlined, thus:

| | |
|--------------------------------|---|
| + 110 ^s : <u>13</u> | means that the clock was found to be 100 sec. slow at 1 p.m. (the normal time for taking time signals) on the second day of the record. |
|--------------------------------|---|
5. In the remarks column the following letters indicate comments most likely to be frequently used:
 - B = Blasting at Lake Shore
 - BT, BW = Blasting at Teck-Hughes or Wright-Hargreaves
 - C = Charging equipment interference
 - F = Finger marks on record
 - S = Stain from developer on record
 - R[±] = Rate of driving clock was accelerated or retarded; indicated by sign after the R
 - G = Interference from games or dancing in the gymnasium
 - Is = Recording light too strong
 - Iw = Recording light too weak
 - Iv = Light variable owing to voltage fluctuation
 - a, b, c, = Index letters to footnotes to etc. tabulation, given at bottom of sheet on which they occur.
 - () = Brackets on any letter denote that the fault reported is relatively small
 - B, R, H = at the end of the remarks line for each entry indicate the name of the operator responsible for the given date

Table 1 as given in this publication is the second of two given in the original report. It is given here to show the methods used to secure continuous and efficient service. There is no longer anything to be gained by presenting all such material in the present publication.

Table 1
KIRKLAND LAKE SEISMOGRAM RECORD

January, 1940.

| No. | Rec'd | On | | Off | | Time Correction | | Bursts | Quakes | Remarks | | |
|-----|-------|-------------|------|--------------|------|-----------------|--------|--------|--------|---------|--|-----|
| | | Time | Date | Time | Date | Value | Amount | | | | | |
| 18 | 5:1 | 12:44 p. m. | 1:1 | 11 a. m. ca. | 2:1 | 1 | + 59.5 | :13 | - | - | Batteries ran down; record fails after 11 a. m. | R |
| 19 | 13:1 | 12:41 p. m. | 2:1 | 1:02 p. m. | 3:1 | 2 | +51.5 | :13 | 1? | - | S, (Iw), B, BT. Light out 3:02 to 3:55 p. m., Jan. 2 | B |
| 20 | " | 1:07 p. m. | 3:1 | 1:16 p. m. | 4:1 | 3 | + 46.5 | :13 | 1? | - | (Iw), B, BT. | B |
| 21 | " | 1:22 p. m. | 4:1 | 1:05 p. m. | 5:1 | 0 | - | | - | - | Clutch not completely engaged; no record. | B |
| 22 | " | 1:10 p. m. | 5:1 | 11:25 a. m. | 6:1 | 1 | + 44.5 | :14 | 2? | - | B, (G), Iw. | B |
| 23 | " | 11:31 a. m. | 6:1 | 1:02 p. m. | 7:1 | 3 | + 37.5 | :13 | 1+? | - | B,C, (G), a. Very good light spot intensity. | ? |
| 24 | " | 1:06 p. m. | 7:1 | 1:03 p. m. | 8:1 | 3 | + 33. | :13 | 1? | - | Is, C, B, G. | ? |
| 25 | " | 1:09 p. m. | 8:1 | 1:03 p. m. | 9:1 | 3 | + 30. | :13 | 2? | - | (Is), B, BT. Very nice rate on clock drive. | B |
| 26 | " | 1:09 p. m. | 9:1 | 1:01 p. m. | 10:1 | 1 | + 26.5 | :13 | 4? | - | B, G, BT. | B |
| 27 | 23:1 | 1:06 p. m. | 10:1 | 1:02 p. m. | 11:1 | 3 | + 23. | :13 | 3? | - | B. Effective light spot intensity. | ? |
| 28 | " | 1:06 p. m. | 11:1 | 1:05 p. m. | 12:1 | - | - | | - | - | No record; clutch out; breaking in a new man. | B |
| 29 | " | 1:09 p. m. | 12:1 | 12:40 p. m. | 13:1 | 1 | + 20.5 | :14 | 1? | - | G,B,C. CHU time signal. | B |
| 30 | " | 12:47 p. m. | 13:1 | 12:32 p. m. | 14:1 | 1 | + 17. | :13 | - | - | B, G, Is (corrected after 1:47 p. m.), b. | A+R |
| 31 | " | 12:37 p. m. | 14:1 | 1:02 p. m. | 15:1 | 2 | + 10.5 | :13 | 1? | - | Iw, (C). Second of two time comparisons used. | B |
| 32 | " | 1:08 p. m. | 15:1 | 1:03 p. m. | 16:1 | 3 | + 7. | :13 | 1? | - | S, Is, B, (G). Well-marked blasting; No. 4 Shaft. | B |
| 33 | " | 1:09 p. m. | 16:1 | 1:09 p. m. | 17:1 | 3 | + 4. | :13 | 1? | - | C, B, G. Bubble blank due to developing (small) | B |
| 34 | " | 1:13 p. m. | 17:1 | 1:04 p. m. | 18:1 | 3 | + 0 | :13 | 1+2? | - | F, B, c. Change to 12-volt charger. | B |

a Small but well-marked burst at 5:09:50 a. m., Jan. 7.

b Dance and card party in gym. evening of Jan. 13.

c Fairly well-marked burst at 10:17:43 p. m., Jan. 17. Was "not located in the mine".

Report B

Initial Mine Research

January 18 to April 15, 1940

B-1 Geology of Kirkland Lake Area and Lake Shore Mines

According to Robson (2), "the productive veins of the Kirland Lake district lie within a belt of metamorphosed tuff, conglomerate and greywacke, which occupies a synclinal trough in the old Keewatin basement". In the vicinity of Kirkland Lake, numerous granitic offshoots, chiefly syenitic types, have intruded the older sedimentary rocks in an area north of the central axis of the syncline. The intrusions occur in the form of dykes and small bosses, which together make up the greater part of the ore zone. This syncline is about 2 miles wide in the vicinity of Kirkland Lake and extends for about 100 miles in a direction roughly east-west.

The orebodies at Lake Shore were deposited in pre-ore overthrust fault zones, the faults being caused by pressure from the southwest. There are two main veins, the No. 1, or south vein, and the No. 2, or north vein. They lie roughly parallel and about 400 ft. apart at the surface. No. 2 vein is 2,800 ft. long from boundary to boundary of the Lake Shore property. The outcrop of the veins has a strike roughly N60°E. The dip varies, according to Adamson (8) "from about 75° to the south, down to the 1200-ft. level, to approximately 87°, also to the south, for 1,800 ft. below this horizon". There are also several important diagonal veins. The plan of these veins at the 3075-ft. level is shown in Figure 8.

The orebodies are thus subsequently mineralized pre-ore overthrust faults. These faults were caused by pressure from the southwest.

The mine has been developed from a series of shafts on a line running at approximately right angles to the veins, at about the centre of Lake Shore property. It is to be noted that, when the mine was first opened, only the south or No. 1 vein was visible on the surface, the north or No. 2 vein being concealed beneath Kirkland Lake, which has since been filled by tailings from the mine.

There is an important difference between the east and west sections of the mine. From a point roughly 200 ft. west of the line of shafts to the eastern boundary of Lake Shore property there lies a porphyry mass that has not been invaded by other intrusives. It has, however, been subjected to post-ore cross-faulting of considerable magnitude. The displacement of both veins at the extreme east end of the property is 600 ft., the eastward continuance of the veins being thrown up into the Wright-Hargreaves property. To the west, the intrusives are in smaller masses, tongue-shaped in horizontal section. Post-ore cross-faulting is here

less pronounced. There are, however, a goodly number of these cross faults joining the two chief veins; these are clearly due to tension. As between the two principal veins, cross-faulting is more pronounced on No. 1. A large pre-ore diabase dyke occurs near the western boundary of the property.

In addition to the post-ore cross-faulting, strike faults are encountered although, with few exceptions, the displacement along them is not great. These dip at a lower angle than the principal veins (as little as 30°) and have a strike slightly more to the north. Tension cracks were developed in some parts of the footwall of the south vein, and thus provided channels in which ore was deposited. Their presence in any part of the development results in increased width of drift and stope.

The north vein is much the more productive of the two larger ore zones. This is due to the fact that it is much more crushed than is the south vein. At various horizons, branching vein structure has resulted in the formation of parallel orebodies. High-grade orebodies as much as 70 ft. in width are found in this vein, particularly in the fractured zone at its junction with the diagonal vein. Because of the more widespread fracturing of the rocks in the west end of the mine, this section has, in general, larger ore shoots than has the east end. A model of the north vein has been constructed, covering the section from the 3075-ft. level to the 4075-ft. level, on a scale of 20 ft. to one inch. Important ore shoots were found in both the south and diagonal veins towards the east end of the property.

The principal fact to note, from the standpoint of rockburst study, regarding the geology of Lake Shore is that the north vein, particularly in the west half of the mine, is much more crushed and fractured than the south. The vein-fracture pattern is made up of several parallel fractures with diagonal breaks joining them, resulting in the formation of roughly diamond-shaped blocks. This structure persists not only in the larger masses, but throughout the blocks of these masses, and is apparent in both cross-section and in plan. A well-developed system of jointing results in weak walls, particularly in the north vein, where crushing has been more pronounced. When the ore is mined, especially if the rock is porphyry, small angular blocks are formed along the walls and, if unsupported by backfill or timber, the sloughing will extend for quite a distance into the walls of the orebody. When the walls are predominantly basic syenite, larger lenticular slabs are formed. They are bounded by smooth surfaces coated with chlorite and other secondary minerals, resulting in treacherous stope walls that require careful attention. In general, the Lake Shore rocks are hard and brittle. The jointing and the numerous contacts of various types of rocks, notably in the west end of the mine, are features that tend to result in the building up of stresses that are released by rockbursts of various types.

B-2 Development

By the term 'development' is meant the work done in a mine to provide access to the stopes or working faces of the orebody and to permit the transportation of ore, waste, fill, and other materials. The development at Lake Shore Mines will be discussed briefly in order

that an index may be placed on record to serve in the case of later references to various mine locations. With regard to nomenclature, it is to be noted that serial numbers indicate the chronological order of development; for example, No. 1 and No. 2 veins as previously noted. Shafts Nos. 1 to 6 were sunk in that order. A drift is indicated by a preceding number of one or two digits as required, to indicate the level, followed by a two-digit number indicating the order of development and followed again by E or W, showing the direction of the drive, e.g. drift 3908W refers to a drift on the 3950-ft. level, it being the eighth drift to be opened on that level, and indicates that it was drifted in a westerly direction.

(1) Shafts and Hoists:

The six shafts at Lake Shore Mines lie roughly on a line that runs at right angles to the veins at about the centre of the property. No. 1 goes to a depth of 4,500 ft. in two stages; the first from the surface to 2,200 ft. and the second offset at the 2000-ft. level, where the hoist is located.

No. 2 is inclined at 18° , extending to the 200-ft. level from what was once a peninsula on the north side of Kirkland Lake. Railway terminals are adjacent to this shaft. A timber-framing plant, timber storage yard, and timber-treating plant are located at its entrance. The fire hazard is thus kept far from the mine proper and the passage of timber and other construction materials into the mine is facilitated.

No. 3 drops from the surface to 4,000 ft. in one stage. Because of the proximity of this shaft to the north vein zone, a portion of the orebody had to be left in place. There was thus a great deal of valuable ore tied up in the shaft pillar and the crushed nature of the rock made the use of the shaft a serious hazard. It has therefore been abandoned for hoisting purposes and is now used as the main upcast airway for ventilating the mine.

No. 5 also begins at the surface and drops to 4,000 ft. in one stage. It was sunk 70 ft. through mill tailings dumped in what was formerly Kirkland Lake, and in spite of the location the water seal is so effective that no water of any consequence enters the mine. There is, in fact, very little seepage anywhere in the mine. Lake Shore may be classed as a dry mine, but the mine air is very moist and in many places the walls are wet. The Geodetic Survey has tied in the collar of No. 5 shaft as being 1051.03 ft. above sea level.

Shafts 4 and 6 extend from the 3950-ft. level to locations in lower horizons of the mine. Shaft No. 6 is temporarily bottomed (as of 1940) at 4750 ft. while No. 4 is being extended below the 5325-ft. level (1940).

For the purposes of this article it is sufficient to note here that:

(a) The line of shafts lies roughly $N30^\circ W$, as shown in Figure 8. The entrance to No. 5 shaft lies farther to the north, along a line from No. 1 to No. 3 and a little west. It is 125 ft. north and 250 ft. west of the collar of No. 3 shaft. It is thus 80 ft. in the footwall of

the north vein on the 200-ft. level and 600 ft. in the foot-wall on the 3950-ft. level.

(b) The hoisting machinery is on the surface in the case of No. 5 shaft, and at the 3575 and 3825-ft. levels in the case of No. 6 shaft.

(c) No. 5 shaft is about 17 x 13.5 ft. in cross-section and is divided into five compartments. The largest of these accommodates the main hoist, which can carry a load of 45,000 lb., and the others carry two smaller hoists, ladders between levels, electric cables, and pipes for air and water.

Stations are cut in the shaft wall at set vertical intervals. From these stations, cross-cuts are run back to meet the two veins. At the intersection of a cross-cut with a vein, drifts are run east and west along the orebody to the boundaries of the property.

Down to 2200 ft., the levels were run at 200-ft. intervals, and below that at 125-ft. intervals. The levels below 2200 ft. were thus run at 2325, 2450, 2575 ft. and so on. No level designation carries the hundred digit 1 or 6.

The drifts were given 4-digit designations, the first two being the hundreds digits of the level and the last two being reserved to indicate the chronological order in which the drift was developed on that level. The letters E and W were added to indicate the direction from the cross-cut. Thus the first drift to be run west on the 2825-ft. level is designated the 2801W drift. A digit following the letter indicates the section. Section intervals are 100 ft., and the number 2801W-8 therefore indicates a section 800 feet west on drift 2801W.

It is natural, then, in referring to a level, to indicate it in even hundreds, e.g. to call the 4075-ft. level the '4000-ft. level'. It must be remembered, however, that the separation in vertical distance between any pair of adjacent levels below 2200 ft. is always 125 feet. Thus the difference in elevation between the '4000-ft. level' and the '4200-ft. level' (the latter properly so called) is 125 ft., not 200 ft., as might be expected.

Throughout this publication, both the true and the conventional level designations are used indiscriminately.

The hoists make regular trips at shift change hours, but at other times operate irregularly, moving ore, waste, and supplies. They can therefore be relied on for transportation at change hours only, although the hoist man can sometimes arrange for travel between levels at other times.

B-3 Mining Procedure at Lake Shore Mines

Practically all mining at Lake Shore is overhead. In the upper levels, shrinkage stoping and stull stoping were used; but, as the mine was developed to deeper levels, the horizontal cut-and-fill methods came into use. There are some shrinkage stopes in the upper levels from which the shrinkage ore has not as yet been removed (1940).

As time went on and the mine was developed below the 2000-ft. level, rockbursts became more frequent and more severe, and square-set rill stoping was adopted. At the present time experiments are being carried on with horizontal cement plugs immediately over the lower drift. Such cement plugs are the full width and length of the stope and 8 ft. deep. In some cases they are reinforced with tension cables and iron rods. Such plugs will, it is hoped, relieve some of the pressure on the stope walls until the ore has been mined out (Figures 47, 58 and 62).

In the west end of the mine, the veins were not mined out for a distance of 100 ft. from the cross-cuts. About the centre of the west end, another section of vein 100 ft. wide was left. These sections are referred to respectively as the shaft pillar and the west pillar (see Figure 8). Raises at the boundary and at the sides of these pillars provided four working faces or stopes, which could be carried forward away from the pillars until they met in the centre.

B-4 Rockbursts in the Kirkland Lake Region

Informative papers on this subject have been published by: Christian (5), Robertson (6), and Robson *et al.* (7). Valuable contributions to the same subject are given in earlier papers by Robson (2) and Weldon (3). These are listed in Section B-6. Some of the points brought out in the papers referring to Lake Shore Mines are noted below:

The governing factors affecting the incidence and severity of rockbursts are:

- Type of rock and its properties;
- Depth of workings, other conditions being equal;
- Dip of the orebody and rock structure;
- Mining methods and speed of operation.

It has been found that:

- Bursting occurs in many instances at the time of, or closely following, blasting;
- Complete extraction of ore is desirable, and the leaving of small pillars*, whether of ore or waste, is to be avoided, so that a gradual and uniform subsidence of the hangingwall may take place;

* The term 'pillar' is used rather loosely to indicate any body of rock or ore with more or less definite, if sometimes only partly visible, physical boundaries (air-rock, air-ore, ore-rock). For example, a section of waste rock between two branches of a drift is a pillar. In Figure 8, we have, in plan, a section of ore 100 ft. long (which is, in elevation, at least 1000 ft.) of varying thickness and cut entirely through at every drift, yet this mass of ore is called the West Pillar. If the ore in any drift in this West Pillar is capable of taking pressure vertically, horizontally, or obliquely, it is itself a pillar. If a stope is mined out from below until a thin section only remains below the floor of the next drift above, it is referred to as a sill pillar or a floor pillar.

Horizontal pillars are a menace and should be avoided or else removed as soon as possible;
Mining out a remnant from two directions is not good practice, regardless of the form of the triangle established;
Steep rills avoid the formation of horizontal remnants and hence are least susceptible to bursts;
Long rills extending from level to level and advancing in the direction of unmined ground are less susceptible to bursts than those mining out a remnant;
The method of mining vertical cuts in short sections is useful in particularly heavy ground, but costs are higher;
Bursts at either side do not transfer through the shaft pillar, nor, in most cases, do they occur close to it;
No bursts have occurred in the vertical pillars formed by the Tech-Hughes boundary line and the diabase dike.

Rockburst types may be listed as:

Strain bursts, affecting the face of workings only;
Pillar bursts, where a volume of rock bursts in a more or less localized part of the mine;
Crush bursts, where larger sections of the mine burst and settle.

The mechanism by which, it is supposed, the large stresses are built up is known as doming. As a section of ore is taken out of a stope, the rock in the wall, with or without partial support of crib and fill, is called upon to hold open the workings. The face of the rock is generally in the crushed region of the vein and has little strength. The stress is supported by the rock behind, which acts as an arch or dome, spreading the stress to the pillar edges. As the workings increase in size, the dome changes in dimension and the stress per unit area on the pillar increases. If this stress exceeds the bursting strength of the pillar, a rockburst results. Doming takes place in the hangingwall at lesser depths than in the footwall.

In the upper part of the mine, there was some displacement of the veins along a strike fault which gave a displacement to the south of as much as 90 ft. in the case of the most prominent strike fault. In this area therefore, the upper workings are over a solid base in the footwall of the vein. The doming caused by the upper workings is thus not carried on downward to the lower levels. This type of fault does not extend below the 1600-ft. level.

The location of rockbursts in the various workings at Lake Shore Mines is given by Robson et al. (7). Some of the larger bursts are described and their effect on timbering and on the circular steel sets is noted.

The prevention of rockbursts has depended in the past, and must continue to depend in the future, on careful mining technique, particularly in the matter of speed. At Lake Shore, to reduce the hazard, two eight-hour shifts only are worked--from 7 a.m. to 3 p.m. and from 7 p.m. to 3 a.m. All major blasting is restricted to the off-shift periods, when only a few workmen are in the mine. The blasts are fired electrically from the shaft station, the stopes being fired in order, beginning with those farthest out.

B-5 Adaptation of Research Program to Mine Conditions

In the foregoing, care has been taken to include all observed data that would affect the design of the research equipment or the planning of the program. All equipment will have to be designed for the conditions found in the mine. Some of these are noted below:

- (1) Equipment will have to be operated in very moist air, but little or no special precautions need be taken against dust.
- (2) Operational noises and electrical disturbances in the vicinity of the cross-cuts that may affect recorders are likely to be caused by: hoists, charging stations, hoist machinery, ventilating fans, ore and waste discharges, fill runs, crushers, annunciator and telephone systems, locomotives and trucks with ore and supply loads, water pumps, and chute blasts to loosen ore.
- (3) Operational noises and electrical disturbances in the drift regions that must be considered may be caused by: drilling, discharges of ore from chutes in the stopes, discharge of fill into stopes, transportation equipment, water pumps, popshots for timbering and placing drills and blasting.
- (4) Equipment must be made in units that can be lifted by one man and loaded into trucks so as to clear all timbering and permit of unloading at its destination.
- (5) Locations for seismic equipment, which will be placed for the most part in the west end of the mine, must be on solid rock. This will mean scaling into the walls and providing cement-lined recesses for the units, which must therefore be as compact as possible. Equipment must be so placed as not to obstruct traffic through the drifts.
- (6) Locations should not be in the west pillar, but as close to it as possible in the drifts.
- (7) As shaft travel is time-consuming, projects should be planned to require as little as possible.
- (8) As the shaft provides ready access to all levels, the problem of installing electric cables would be mainly one of expense, should it be decided to set up a surface recording system.
- (9) As the only electric service in the stopes is for blasting purposes, equipment should be battery-equipped as far as possible.
- (10) To avoid using mine trucks, a light service truck that can be lifted from the track should be provided.
- (11) The uniform temperature conditions do not present a problem for seismic equipment and the situation is favourable to studies on temperature effects within the pillars due to changing pressure.

(12) Since all workings are interconnected, it should be possible to record with seismometer and microbarograph at the same location and obtain some indication of the position of a burst from the time interval between the elastic wave through the rock and the shock wave through the air.

B-6 References for Preceding Sections of Report B

1. Todd, E.W. Kirkland Lake gold area. Ontario Department of Mines, Vol. 37, Part 2, Toronto, 1928.
2. Robson, W.T. Lake Shore geology. The Canadian Mining and Metallurgical Bulletin, No. 287, Montreal, March, 1936.
3. Weldon, Leslie S. Mining methods and practices at Lake Shore, Ibid.
4. Dougherty, E.V. Some geological features of Kolar, Porcupine, and Kirkland Lake. Economic Geology, Vol. 34, No. 6, Lancaster, September-October, 1939.
5. Christian, J.D. Rockbursts at Teck-Hughes. The Canadian Mining and Metallurgical Bulletin, No. 331, Montreal, November, 1939.
6. Robertson, A.F. Rockbursts at Wright-Hargreaves, Ibid., No. 332, December, 1939.
7. Robson, W.T., J.C. Adamson and W.E. Selnes. Rockbursts at Lake Shore Mines. Ibid., No. 333, January, 1940. (Excellent rockburst bibliography appended).
8. Adamson, John C. Construction and equipment of No. 5 shaft at Lake Shore Mines Limited. Canadian Mining Journal, Vol 61, No. 1, Gardenvale, January, 1940.

B-7 Initial Program Planned and Equipment Provided

The aim of the March program was to determine the nature and occurrence of mine noises that might, by their chronological pattern, indicate that a pillar was in danger of bursting. As nothing was known as to the vibration frequency of such noises, two frequency ranges in detectors were required. A Heiland geophone covering the frequency range from about 20 cycles to 75 cycles (see Figure 18 for interior construction) and, for the higher frequencies, a Brush crystal detector (Type DP-1) ranging from about 1 cycle to a little over 5000 cycles, were purchased.

The amplifier for use with the above detectors was built by Hollinsworth for another purpose, but was made available through the courtesy of the Dominion Astronomer and Mr. Hollinsworth. The amplifier was designed to have a linear amplification over the combined range of both detectors, but had not been tested and modified when it was taken over for this work.

The recorder was built at the Observatory under the direction of Hollinsworth and according to his design. It records with ink on ordinary paper. For details of the pen see Figures 19 and 20. The pen is mounted at right angles to the axis of a Milne-Shaw recording drum, which uses a sheet of paper about 10 by 19.5 inches, travelling at 8 mm./min. To mark time, an alarm clock was fitted with a minute contact operating a relay through two

No. 6 dry cells. The relay, in turn, supplied current from a single No. 6 dry cell, through a rheostat, to the loud-speaker unit of the pen. The rheostat permitted the amplitude of the time marks to be adjusted. A small copper oxide rectifier between the amplifier and the speaker unit of the pen was arranged so that all mine noises were recorded by a downward mark of the pen. The time marking device was arranged to move the pen upwards to mark the minutes. The recording assembly is shown in Figure 20.

The recording unit and amplifier were mounted in a wooden case, the latter in the lower part and the recorder in the upper. Holes in the shelf allowed the heat from two 40-watt lamps to reach the recorder. This was found to be ample protection against the dampness of the mine.

As set up in Section 8W of 2901W, the crystal detector was suspended on the drift wall. The rock was spalled at all points in the vicinity, so the detector did not rest on solid rock. For this same set-up the Heiland geophone was set firmly wedged on loose rock on the face of the drift. More solid conditions were available in the second set-up in 3908 (south drift). These are shown in Figure 21.

B-8 Recording Program as Implemented

(1) Mine Seismograph

The equipment was received at Lake Shore early on Monday, March 11, and was immediately set up and tested. The instruments were set in place and connected at a location in the unused south drift about 90 ft. east of cross-section 2909 on Tuesday.

The installation began operating on Wednesday, using the Heiland geophone, but, as a result either of faulty adjustment or dampness, the recording pen lost contact soon after operations began and the ink dried in the pen, with the result that no data were recorded for the period March 13-14. On March 17 the Heiland geophone was replaced by a crystal detector, and good 24-hour records were obtained for the next three days.

On the 20th, the installation was moved to the east end of 3908W, where good records were obtained up to the 26th--the date of the report. The detector was first attached to a post resting on service pipes running along the floor of the drift, but it was pointed out that these pipes carried tremors resulting from normal mine operations, so on the 25th the supporting wires were fastened to the rock (Figure 21).

Each day, the records were compared with the mine captains' reports showing the amounts of explosive used and the nature of the rock blasted. Special reports on the positions and times of all popshots for timbering were also received and, for one day, a report on the movements of electric trains in the vicinity of the west pillar on the 3950-ft. level. Full 24-hr. runs were obtained regularly except for the first two days, when the pen ran dry. The record for March 19-20 is shown in Figure 17.

(2) Surface Seismograph

The surface seismograph was completely overhauled and the timing circuit was arranged to operate from a dry cell instead of from the battery supplying the light source. This eliminated any possible interference by the charging generator. The efficiency of the surface installation was greatly enhanced and served as a valuable check on the mine seismograph.

As it was sometimes impossible to receive time signals, even from NAA, the aerial was taken down and re-wired, the dimensions being changed. The long wire was cut and three insulators were inserted at intervals of 66 ft. From the middle insulator an ordinary lamp cord was run to the receiving set. Each conductor of the lamp cord was soldered to one 66-ft. length of the antenna. When connected to the receiver as a 'half-wave doublet', this antenna gave excellent reception of CHU on 3330 Kc. and reduced the static. By changing the method of attaching the feeders to the receiver, the antenna may be used as a simple capacitive antenna. Knife switches were mounted on the wall of the radio room to facilitate the change. Operating as an ordinary antenna, the signals from NAA were better than before, owing mainly to a better signal-to-noise ratio obtained with the effectively shorter antenna.

B-9 Deductions from Data Obtained

Observed results of the short recording program carried out with the mine seismograph follow:

- (1) All blasting and all reported bursts in the region of the west pillar appeared to have been recorded by the mine seismograph.
- (2) The crystal detector was more sensitive for both the blasts and for the few small strain bursts experienced during the experimental runs.
- (3) There seemed to be no record of any noises in the mine other than those due to mine operations and to the strain bursts reported. A few other shocks seemed to have recorded in the same way as strain bursts and appeared on the charts of both mine and surface seismographs. These were probably due to small strain bursts not located by the miners.
- (4) No mine noises, as distinct from strain bursts were reported in the vicinity of the west pillar since recording began. The mine was not 'talking' or 'cracking'.
- (5) Dumping of ore or waste rock through the chutes was not recorded except at the set-up in 3908W where the chutes were very close and the recording was affected by the improper attachment of the detector wires.
- (6) The seismograph, when in 2901W, picked up small blasts from greater distances than when in 3908W.
- (7) The seismograph seemed to pick up small blasts from greater distances below it than above, indicating that the energy of a blast travels more freely upward than downward; e.g. when in 2901W it recorded small blasts in the 5300 cross-cut with equal or greater amplitudes than when in 3908W.

- (8) Rock drills did not affect the seismograph, even when operating quite close by, e.g. in the stope above 3908W.
- (9) Locomotives and trains, even when loaded, did not record unless passing very closely. Detailed reports of locomotive operation were obtained for one day only.
- (10) Strain bursts gave no warnings that can be detected on the slow time scale of the recording drum (paper speed 8 mm./min.).
- (11) Experience indicated that the detector (crystal or geophone type) should be installed on solid rock, with no direct connection to timbering, piping, electric services, or tracks.

B-10 Limitations of Equipment

It will be clear from the foregoing that the assembly had to be improvised at short notice, with no definite knowledge of the frequency characteristics that were to be measured, and it seems certain that even if some of the recorded offsets were due to mine noises as distinct from operational ones, it could not give a clear picture of mine noises alone.

If, therefore, the investigation was to continue new equipment would be required. The two detectors would cover a frequency range to 5,000 cycles, but a third unit to extend the frequency range to at least 10,000 cycles would have to be added. It would also be necessary to build an amplifier that would filter out operational noises and record mine noises only. This phase of the problem is discussed later.

The investigation generally had proved well worth while, showing the general noise level in the mine and demonstrating the feasibility of operating delicate detectors underground. It was, however, clear that for a regular program a new type of recorder would have to be developed.

B-11 Instrumental Criteria for New Recorder

(1) Listening Post Equipment:

Listening post equipment should have a variable-speed recording unit so that it may be speeded up at those times of the day when it is desired to get a clear record of the nature and frequency characteristics of certain noises. The amplifier should be equipped with filters that would enable the operator to confine the record to those sections of the frequency spectrum that it may seem desirable to explore. Equipment that meets these criteria was available commercially, and it therefore seemed better to make a selection of the various commercial units and then build them into a coordinated whole, than to attempt to build an outfit from the ground up.

The coordinated equipment should have a portable recording unit, operating on A.C. or batteries, that would record with ink on sprocket-driven paper charts at any desired speed:

- (a) all noises, as to amplitudes
- (b) the amplitude of noises of segregated bands of specified frequency, or
- (c) the frequencies of all noises, regardless of amplitude, thereby identifying the type of sound and, probably, its source.

It would be desirable to perfect a single unit at first: it would then be possible to locate all the recorders in the office building on the surface. The only difficulty in such an arrangement would probably be the expense of providing shielded cable connections from the various detectors to the central recording station. The advantages of such an arrangement are obvious, but it could not be recommended until all experimenting with a single recording device had been satisfactorily completed.

(2) Time-recording Devices:

The most serious instrumental difficulty in carrying out a research program on seismic velocities would be in securing time-measuring devices of the necessary sensitivity and precision. The total time for a seismic wave to travel 1000 ft. in a pillar would probably be about .05 sec. The shortest distance of travel involved in the program would be about 100 ft. which would involve a travel time of .005 sec. Variations in total time, which would be the quantity required for burst prediction purposes, would thus be about .0001 sec. To do this, clear and accurately timed lines would have to be photographically recorded at intervals of .001 sec.

(3) Strain Meters:

If strain meters were to be used in the drifts, it would be very desirable first to study closely the extensive work previously done in this field.

The meters would have to be installed at numerous points, and it would be necessary for readings to be taken regularly and frequently, and for the results to be kept tabulated right up to date.

In some cases, the variation in dimensions of the pillar itself could be taken with a constant tension device suggested by Gibbs, provided it were possible to drill a hole completely through the pillar from stope to stope and from drift to drift. Such a procedure would be very informative. It could probably be used to advantage in small pillars.

B-12 Laboratory Facilities Required

For a continuing research program facilities would have to be provided at the outset for an electronics laboratory. Such a laboratory should be light-tight, ventilated, and provided with hot and cold water, A.C. and D.C. power supply, compressed air, and gas. An oscilloscope, frequency standards, etc. would be needed, as well as the necessary measuring devices, tools, and supplies.

B-13 Interim Program Proposed

The interim program described below would require a year or more of experimenting until suitable equipment for measuring the various physical properties of the rock in the mine was developed. It might, perhaps, evolve the chronological pattern of the physical phenomena, significant for the purpose of rockburst prediction. Whether it did or not the necessary pattern of routine observation would then be indicated and an established routine program could be planned.

Five distinct types of investigation are recommended. The details of providing for each of these (from the point of view of the difficulties involved) have been treated in sections B-13 and B-14. The present section sketches briefly the proposed method of attack in each case and the equipment required.

(1) **Listening Post:**

If a single listening post only is planned, it should be a portable type that could be set up at various points. Battery-operated equipment is indicated.

(2) **Velocity Measurements:**

The west pillar is at least 1000 ft. in height, measured along the dip of the veins. If a seismic prospecting outfit were obtained, the recording unit could be set up in some convenient position in a drift midway of the pillar and cables run up and down to several geophone pickups sealed in suitable positions at various heights in the pillar walls. Arrangements might then be made for a five-minute stoppage daily at some convenient time for observational purposes.

At this time, a shot of approximately one stick of dynamite would be fired at a selected point in the pillar. A wire would have been run previously from the recording unit to the firing point. This wire would be left in place from day to day to record the instant of discharge. The camera would run through about 30 inches of paper per second, recording the arriving tremors in full detail.

Such a record would show to .0001 sec. the travel time from the shot point to each of the geophones and would thus give the times for several paths through the pillar. By firing at

several points, the number and position of the travel paths could be increased for each firing position. The geophone would remain in position, the recording unit would be sealed and left ready for operation, and the lines to each firing position would be left in place.

The shifting of stress from one part of the pillar to another as mining progressed would reveal itself in the relative movements of the plotted travel times for the various paths. Such a composite graph would be most informative.

(3) Strain Meters:

It was proposed to place these in numerous positions in drifts throughout the west pillar region and also, if possible, in some of the smaller pillars, as well as in the east side of the mine. They would be set in place permanently and read at frequent intervals.

(4) Thermometric Measurements:

It was considered that instruments for this purpose could best be built by Gibbs and installed by him at no cost except for supplies. One or two experimental stations would suffice for the duration of the proposed interim program.

(5) Fault Markers:

It would involve very little expense for the construction and installation of devices for measuring the amplitude and direction of slow displacements along the plane of all major faults exposed in drifts. These would be designed to involve a minimum of servicing. Some thought was given to this form of research and several designs for such markers were discussed.

Fault markers should be installed in the east end of the mine also, where faulting is more marked and, presumably, more active. The tabulated results would be obtained at a minimum of expense and trouble and should prove most informative. It was recommended that the installation and servicing of such markers be included in any continuing program adopted. The expense, other than overhead, would be purely nominal.

Note: In all the above, except as noted, it was proposed to confine the investigations to the west pillar, where conditions were more simple in that there were fewer faults. The pillar, too, was smaller, and was changing more rapidly as mining progressed.

B-14 Conclusions

The five forms of investigation proposed above, if carried on simultaneously, would give a comprehensive picture of the tectonic conditions in the mine. No such concerted attack on the problem of rockbursts had ever been attempted in Canada, so far as the writers were aware. Indeed, until quite recently, electronics was not sufficiently advanced to allow such

work to be carried out.

The data obtained from this interim program would be of ever-increasing value. It was considered that the ultimate goal of rockburst prediction was more nearly possible than had been thought and that the proposed program was a reasonable method of procedure towards that end. Its adoption as a coordinated whole was recommended.

Report C

Initiation of Interim Program

April 15 to August 15, 1940

Two reports dealing with the seismic research program being carried out in collaboration with Lake Shore Mines have already been presented, covering the work up to the middle of April, 1940. The present memorandum is designed to bring the detailed account to August 15.

C-1 Report of Progress, April 15 - August 15, 1940

At the date of the second report, Gibbs was just returning to Kirkland Lake, after two weeks spent at Ottawa in building an amplifier. It was expected that the surface seismograph would be ready to ship to Kirkland Lake in two or three weeks. In the meantime, the seismograph constructed by Hollinsworth and used in the mine during March was to be continued in operation at the surface station at the mine in order that the program of accurately timing the bursts might not be interrupted.

The electronics laboratory was completed about April 20: it was located in the Accommodation Building as had been recommended. The only current available was 25-cycle.

Recording by the surface seismograph began July 2-3 and was practically continuous for the remainder of the period.

The Hollinsworth seismograph, held on surface until July 2, was returned to Ottawa. In the meantime, Gibbs completed a new mine seismograph, building an amplifier and related equipment and using a commercial Esterline-Angus recorder. After a period of testing and adjustment on the surface, this seismograph was placed in a specially prepared position on the 2950-ft. level on June 10 at the point first occupied during the March experiments by the Hollinsworth instrument.

As was the case with the Hollinsworth seismograph, the records on the new instrument were confused by man-made noises: blasting, tramming, etc. It was believed that in many cases the blasts initiated bursts. If so, many of the offsets at blasting time were probably due to small bursts. During the relatively quiet off-shift periods, the recorded disturbances were few, and were almost certainly due to small strain bursts.

It was considered that a seismograph that would not register mine noises but would record bursts was needed. Such an instrument could be built if the frequencies of the vibrations at the time of a burst differed from those resulting from man-made noises. If the frequency ranges were known, filters could be constructed to pass only that part of the spectrum

desired. Much time was spent in an endeavour to determine these frequencies, but without success. This problem had to be solved before further work could be efficiently carried on.

Rockburst research was initiated by The International Nickel Co. of Canada Ltd. at its Frood mine in December 1938, under the general superintendence of R.D. Parker, General Superintendent, Mining and Smelting Division, and Dr. Arthur B. Yates, Chief Geologist. Close collaboration was arranged between those working at the Frood mine and the group at Lake Shore. Data were exchanged on amplifiers, etc. and complementing programs were arranged. In the case of one rather costly project (determination of vibration frequencies) the experiments were planned to be done in both mines, the overhead cost of equipment being shared. Steps were taken to calibrate the seismometers and amplifiers used, so that the records might be compared qualitatively.

On June 11, Messrs, Parker, Yates, and Shenon visited Lake Shore Mines for a conference on geophysical methods of studying the rockburst problem. It was arranged that such visits should be interchanged from time to time, and on July 30-31, Gibbs and the writer visited the Frood mine for a conference on a continuing program.

The Ontario Mine Operators Association appointed a special committee on rockbursts with R.D. Parker as Chairman. The committee arranged for a visit by G.K. Morrison of the Nundydroog Mines, Mysore State, India, an authority on rockbursts, which he had studied in India, South Africa, and Canada. In the course of this visit, the writer had the benefit of several long conversations with Mr. Morrison.

A report on the rockburst research at Lake Shore was presented by the writer at the Annual Meeting of the Royal Society of Canada at London, Ontario, on May 20. At that time, Prof. E.S. Moore of the Department of Geology, University of Toronto, made available to the research program data from a series of tests on the strength of various samples of Lake Shore rock, studied under his direction some years ago at Toronto by C. Godefroy. He stated that he would be glad to try to arrange any cooperation with his Department that might be desired. The work had, however, not proceeded far enough to permit the formulation of definite problems that could be presented for solution with the aid of the University's trained personnel and special equipment. Similar offers were received from the Department of Physics of the same University. It seemed likely that, as the work proceeded, special problems would arise that could be submitted to such organizations with advantage.

E.W. Todd resigned as Superintendent at Lake Shore Mines on June 22, and his successor, A.L. Blomfield, Managing Director of Lake Shore, indicated that the program of rockburst research was to continue.

A memorandum presented to Mr. Blomfield on August 6 suggested that the detailed geological studies made in the mine after all bursts be made immediately available to the rockburst investigators. At the same time it was recommended that an assistant be appointed

to help Gibbs. It was decided to engage an geologist, Howard M. Butterfield, to take care of the geological side of the work and to collaborate with Gibbs.

C-2 Alterations to the Surface Seismograph

The clockwork drive of the surface seismograph, adopted to render the instrument independent of power interruptions, had proved not entirely satisfactory, and further trouble arose from the deterioration of the two mirrors used in the light track. It was therefore decided to send the instrument to Ottawa to have a synchronous motor drive installed in place of the clockwork drive, to have it fitted with change gears permitting speeds of 30 to 60 mm./min., and to have the optical system re-designed so as to eliminate the mirrors and prism. In its absence, the Hollinsworth seismograph, designed for underground use, was brought to the surface. As this instrument has a paper speed of 9 mm./min. only, the timing was not as accurate, but the recording of blasts and bursts was excellent.

Specifications for the motor, ordered from the Bodine Electric Co. of Chicago, called for Type KYC-22RC 110v., 25-cycle, 1500:1 reduction, 1 r.p.m. While awaiting delivery, the optical system was changed. A new type of lamp suggested by Gibbs was found to give excellent results. This was a precision lamp used in large quantities by the motion picture industry, known as a pre-focused photo-exciter 4A, 8.5v., and available at a cost of only 50 cents. Replacement merely required the removal of the old lamp and insertion of the new, without any of the delicate adjustments necessitated by the former type. It proved so satisfactory that it was adopted as standard equipment at all Canadian seismograph stations. The new system, designed and made in the Observatory machine shop, eliminated the prism and mirrors, thus increasing available light.

The new optical system on the Kirkland Lake instrument located the lamp at the rear of the recorder case. The power supply was furnished through a Thordarson transformer from the 110v., 25-cycle service. The light beam traversed a series of baffles in a light-tight metal case to the galvanometer, which was mounted on a weighted base independent of the case. After reflection by the galvanometer mirror, the beam passed through a cylindrical lens mounted in a hole cut in the rear of the old case. The focused point of light fell on the rear of the drum.

Work on the gear system, designed to give paper speeds of 30 or 60 mm./min., began as soon as the motor was received, and the machine was shipped to Kirkland Lake on June 27. Installation was completed by July 2, and the instrument has functioned practically continuously since. The only modification found necessary was a slight adjustment in the lighting system designed to reduce the intensity of the recording spot except when a burst is in progress, when the light is brought up to full strength.

As the optic axis of the new system was only about .6 as long as the one it replaced, the magnification was proportionately reduced. However, experience shows that this is not a disadvantage, as all bursts record on the new system.

The Heiland Research Corporation supplied the design of a battery-operated amplifier, and such an amplifier was constructed by Gibbs. It proved quite satisfactory except that it shorted the timing impulse to the galvanometer so that all the time marks were lost. Pending the design of a semaphore timer to be placed in the light path in lieu of the impulse to the galvanometer, the use of the amplifier was discontinued.

The power source at Lake Shore Mines since April 30, 1940 has been the Hydro system. The frequency control has been excellent, as the sample record shows; the interruptions have been few and of short duration. Of course, when such interruptions did occur, the timing of bursts ceased. Except for this drawback, the modified equipment proved much more satisfactory than the former design. It should be said, however, that the difficulties experienced with the first set-up did not arise from any defects in manufacture, but from the specifications, which stipulated that the apparatus was to be designed so as to be unaffected by interruptions in the power supply.

C-3 Construction of the Electronics Laboratory

Work on the electronics laboratory began on April 11, and although all the work had not yet been done, Gibbs was able to move into it on May 15. It was felt that some of the more expensive testing instruments came under the classification of instruments for scientific purposes as regards customs regulations, as they would be of no use to Lake Shore Mines except for the rockbursts research. Accordingly, these were purchased by the Dominion Observatory with the understanding that Lake Shore Mines would reimburse the expenditures incurred, and that the instruments would remain at Lake Shore for at least 10 years, or longer if circumstances should so require. A list of the equipment, ordered from General Radio Co., Cambridge Mass., follows:

Two Variacs (200-CMH)
and one each of the following:
Impedance Bridge (650-A)
Beat Frequency Oscillator (713-BM)
Output Power Meter (583-A)
Microvolter (546-A)
Sound Level Meter (759-A)
Sound Analyser (760-A)

The best frequency oscillator was designed for 25-cycle current: the other equipment was battery operated. All instruments were received at Lake Shore Mines on August 15.

C-4 Experimental Work to August 15

The experimental work for the period covered by this report was as follows:

- (a) Design and construction of a strain gauge;
- (b) Design, construction, and tests of a mine seismograph;
- (c) Frequency tests in the mine.

(1) Strain Gauge:

The strain gauge constructed by Gibbs consisted of a heavy brass cylinder with an internal diameter of one inch, closed at one end by a piston working through a packed sleeve. The other end opened into a glass tube at right angles to the brass cylinder. The ratio of cylinder area to tube area was 12:1. This was expected to give sufficient magnification. The liquid proposed for use in the gauge was a coloured light oil. The gauge (Figure 22) was not set up in the mine as it lacked a recording system.

Steps were taken to design and construct ten recording gauges to be operated in the mine at strategic points to be selected by the geological department.

(2) Mine Seismograph:

A mine seismograph designed and constructed by Gibbs was in practically continuous operation on the 2950-ft. level from June 10 to date. The design of this seismograph depended on the solution of a series of problems here discussed briefly:

(a) Power Supply Frequency:

The frequency of the power supply at Lake Shore Mines is 25-cycle. Nearly all commercial testing equipment required for the laboratory is designed for 60-cycle. It was a question whether equipment should be selected and designed for 25-cycle or whether converters should be used to change the supply to 60-cycle. It was finally decided to adapt all equipment to either 25-cycle or to battery operation.

(b) Seismograph Design:

The pick-ups for this instrument were the Heiland geophone and the DP-1 Brush vibration detector purchased by Lake Shore Mines for use in the March experiments. The recorder selected was a commercial 5-milliampere Esterline-Angus meter. This instrument uses a paper chart run normally at 3 in. per hour, but capable of a variety of speeds for experimental purposes. Registration is by means of ink, using a special pen.

The power pack and amplifier were built by Gibbs. Tests of this instrument on the surface showed that voltage fluctuations affected the over-all magnification to an extent that precluded intercomparability of the records. A voltage regulator was therefore designed and built by Gibbs, and gave excellent results.

The amplifier and meter were originally used with the DP-1 pick-up. The combination worked quite well until about the end of June when it suddenly failed. Examination showed that moisture had affected the crystal of the DP-1, so the unit was returned to the manufacturers to be repaired.

With the DP-1 out of commission, the Heiland geophone was installed, but the results were not satisfactory. The amplification was much too low, and the geophone and amplifier were not impedance-matched. A matching transformer (Hammond No. 910) was tried with excellent results. The available gain of the amplifier was now more than adequate and, in fact, when used to the full, brought in mine noises to an extent that seriously affected the record. This arrangement continued to date, the installation being on the 2950-ft. level, where a special pier was constructed on solid rock for the pick-up location. The power pack, amplifier, and Esterline-Angus meter are housed in a special steel box as shown in Figure 24 (the meter itself being just out of the picture on the right). Figure 25 shows the entire outfit as set up in the drift, and Figure 26 a typical record.

The records showed clearly that small bursts probably occurred during blasting and that they certainly occurred at intervals during off-shift hours. Even comparatively large bursts did not go off scale on this seismometer. The gain was linear for about half the full scale and then diminished rapidly. For example, bursts marked as such were perhaps tenfold as severe as the heaviest bursts occurring during blasting time.

Experiments at the Frood mine gave some promising results. All bursts occurring there were plotted on an empirical vertical scale designed to show integrated total intensity, with a horizontal time scale. The resulting curve, extending over some months, shows a distinctive pattern after and before large bursts. If the records could have been cleared of all mine noise records and confined to bursts alone, this pattern would probably have become sufficiently distinct to permit approximate prediction of large bursts. Clarifying the record would have been possible if the vibration frequencies of blasts and bursts differed materially. It was suggested at Frood that the frequency of bursts was from 20-40 cycles, and that of blasts from 40-80 cycles, but it seems doubtful if the evidence given by the experimental data is sufficient to warrant this conclusion.

(c) **Frequency Problems;**

With a view to determining the frequency of bursts, a head set and an oscilloscope were arranged in multiple at the same amplifier output. It was thus possible to hear and see the oscilloscope record and, at the same time, the record of the Esterline-Angus meter. The results were too uncertain to be of any value. Attempts to use photographic paper to record the oscilloscope picture were not successful. It was hoped that the seismic prospecting apparatus might enable the operators to solve this problem of vibration frequencies.

C-5 Plans for the Immediate Future

In addition to the proposed strain gauge program, plans for the immediate future called for a new set-up of the mine seismograph for the vibration frequency tests, and for experiments to determine whether supersonic vibrations (very high frequency and low energy level) occur before a burst and reveal by their presence the approach to bursting conditions

in a rock under pressure. These may be outlined as follows:

(a) **New Location for Mine Seismograph:**

An excellent location for the mine seismograph was found in a long cross-cut on the 3075-ft. level. This cross-cut ran north from the drift on No. 2 vein for about half a mile. It was an exploratory working, no longer in use. It was planned to instal the seismograph there as soon as Gibbs could build an amplifier that could be operated on batteries, there being no power supply in the cross-cut. The seismograph station was at a point on the west wall of the drift about half-way between the junction of 3053W drift and the indicated Lake Shore boundary.

(b) **Velocity Tests:**

Authority having been given to lease a seismic prospecting outfit from Dr. L.D. Leet, tests with it were planned for Lake Shore and one of the mines of International Nickel, which was sharing the expense of this part of the investigation. The tests were aimed at finding the velocity of transmission of the elastic waves for both bursts and blasts. Variations in this velocity over certain selected paths were also to be studied. The instruments would also make it possible to determine the vibration frequencies of both bursts and blasts.

(c) **High-frequency (ultra-sonic) Vibrations:**

It seemed possible that bursts might be preceded by frequency vibrations that would, if they could be recorded, furnish a means of burst prediction (see No. 47, bibliography). It was planned to begin studies along these lines as soon as possible. To this end, two high-frequency Brush pick-ups were purchased; these are known as the VP-1 and VP-2. With suitable filters and matching transformers they were to be used with the equipment set up in the long cross-cut on the 3075-ft. level.

C-6 Yates-Shenon Memorandum on Lake Shore Conference

The conference on rockburst research, held at Lake Shore Mines on June 11, 1940, was mentioned in section C-1. A summary of the discussion follows:

Library:

A complete bibliography of papers and reports covering rockburst and allied subjects has been compiled and libraries of rockburst literature are being assembled by the Ontario Mine Operators Association at Toronto and at some of the mines.

Investigations:

Critical parts of mine workings have been mapped in great detail to determine the disposition of rock types, faults, and joints in an endeavour to determine if there is any correlation between these structural features and the locations of rockbursts. It has been found that, in general, rockbursts are confined to the more brittle or friable rocks and that major structural features influence their location; for example, intersections of vein or fracture systems, major irregularities in orebody outlines, close spacing or parallel

orebodies, and the presence of many closely spaced joints and fractures. The object of this work is to furnish data that will aid in planning of mining methods and proper mining sequence to control, as far as possible, the occurrence and severity of rockbursts.

Engineering and geological records of rockbursts have been kept for a number of years as a basis for statistical analysis, which has led to a better understanding of the contributing causes of the phenomena. Charts, plans, and sections showing the location, time, frequency of occurrence, extent of damage, relative intensity, and sequence of bursting have been prepared. From these data an understanding of the space relationship of bursts to the physical condition of the mine as a whole may be obtained. Study of such data also aids in the determination of critical areas.

Many attempts have been made by means of various micrometer bars, extensometers, and gauges to measure small movements within the walls of various mine workings to ascertain if there are indications of movement within the elastic limit of the rocks that might indicate areas within which unusual stresses are being built up to produce rockbursts. Thus far it has been found that slabbing along the walls and differential movement along small joints vitiate results. Some work has been done and further work has been planned to determine temperature changes in areas known to be undergoing increasing pressure, in the belief that the rate of temperature increase may give a measure of the accumulating stresses that cause rockbursts and thus furnish a basis for predicting their occurrence.

Apparatus has been constructed and installed in several places in two mines for the purpose of recording vibrations within the rock structure set up by stress releases. The immediate object of the work is to relate these vibrations to subsequent rockbursts and to attempt to give adequate warning of the forthcoming bursts. Enlightening data have been obtained with reference to the time pattern of the minor readjustments preceding major movement and it is hoped that eventually results will be consistent enough for reliance to be placed on their interpretation. A specially designed seismograph has been purchased and put into continuous operation in coordination with the Dominion Observatory of the Department of Mines and Resources. Dr. E.A. Hodgson, Dominion Seismologist, is working in close cooperation with the technicians employed by the mines for this special purpose and is devoting considerable time and energy to the problem.

A very well-equipped laboratory supervised by specially trained scientists has been set up to develop and construct instruments for use in this investigation. New types of extremely sensitive electronic apparatus, much of it especially designed and constructed, have been applied to the problem, and while it is too early to cite specific examples, sufficient encouragement has been attained in the short time in which these methods have been in use to hold out the promise of valuable contributions to the safety of deep mining operations.

Report D

Surface Seismograph Records

Dec. 19'39 - Dec. 31'40

This report discusses the records made in the course of the regular surface recording from December 19, 1939, when the work began, to the end of 1940. A comprehensive summary is first given, followed by a discussion of the data under various headings. A tabular record of the entire set of individual seismograms, prepared in accordance with the initial form as given in Report A, Table 1, completes the report.

D-1 Summary Discussion

The maintenance of a surface seismograph at Lake Shore Mines could serve only two purposes: to furnish data for an accurate determination of the velocity of propagation of elastic waves in the upper surface layers and to provide a complete record of the rockburst activity over a period of years and determine whether it is growing or not. The former is of considerable value from a purely scientific point of view.

To accomplish this velocity determination it was necessary that the absolute time of all large bursts be known to within a half second, or less if possible. Any interruption to the seismograph or its auxiliary time equipment might mean the loss of data for the obtaining of which opportunities are so rare. Moreover, the chronometer correction must be obtained accurately and regularly. All adjustments affecting the chronometer and its rate should be immediately noted in detail on the back of the corresponding seismogram. Only in this way can a complete and accurate time correction be obtained.

To accomplish the second purpose, studies of rockburst incidence, there must be prompt, regular, and careful correlation with the seismograms of data from the underground superintendent's office.

Except for lost time, the surface seismograph recorded all bursts of even moderate intensity with a timing error which was, in general, $\pm .5$ sec. and seldom if ever greater than ± 1.0 sec. No burst of moderate intensity seems to have occurred during any lost-time period, and certainly no burst large enough to have served for a velocity determination. Finally, it must be recorded that no velocity determination has been made, as yet, in more than a year of recording. As for the complete tabulation of all bursts and their relative magnitudes as experienced at the surface station, the service fell far short of the possibilities. Interruptions due to required modifications of equipment were past, and the sensitivity seemed adequate. Although it was not as high for Series III as for Series I, the recording seemed to be a better indication of burst activity with less disturbance from adjacent conditions in the gymnasium, etc. The records for 1941 would be much improved with a daily

sensitivity test and daily correlation of data; the first of these was planned for the near future.

D-2 Lost Time

One of the chief reasons for installing and maintaining the surface seismograph was to determine accurately the speed of propagation of the elastic waves in the upper part of the earth's crust for the path from Kirkland Lake to Ottawa. To do this, the Kirkland Lake instrument must be operating at the moment when a burst of sufficient magnitude to register at distant seismographs occurs. To be of any value, the record must carry regular chronometer minute marks and the correction for these must be known.

If such a burst occurred at a moment when any one of the above conditions failed, the opportunity for obtaining a velocity measurement would be lost. It was therefore important to reduce servicing stoppages to the absolute minimum. The time required to change the seismograph sheets varies from a few seconds to several minutes, and was necessarily designated as lost time.

There were other causes of lost time that were in some cases unavoidable and in others must be classed as due to the carelessness of the operator. These causes have been listed in the legend section of the table, the actual time lost on account of these various causes being indexed in the body of the table. All entries are to the nearest minute.

Where the chronometer signals were not, for any reason, shown on the record, the time was irretrievably lost and the fact was therefore included in the tabulation. This was especially serious when the cause was failure to wind the chronometer. In such circumstances, the time without signals was lost and the chronometer rate also was usually affected.

Time lost for the period of this report (378^d 12^h 25^m) amounted to 33509 min. (23^d 06^h 29^m) or 6.14 per cent. It was hoped that this lost time could be brought down to at most 2.5 per cent for 1941 (see section G-2).

D-3 Chronometer Corrections

Time comparisons between the chronometer and radio signals were made usually once a day, though there were a few periods in which the comparisons were somewhat irregular. In general, the comparisons were good, most of them being automatically recorded on the seismograms. During the interim period of Series II (April 1 to July 2), automatic recording was not attempted, as the paper speed of the mine seismograph was then only 8 mm./min. For the time of this series, the comparisons were made by eye-and-ear method, a single signal being put on the seismogram by means of the telegraph key. The correction, as estimated by looking at the second-hand of the chronometer while listening to the radio signal, was also kept as a desk memorandum.

In preparing this report, the chronometer corrections were obtained from the records or from desk memoranda. They were plotted on cross-section paper to a scale of .1 in. = 1 sec. correction and for the other coordinate 1 in. = 1 day. Through these plotted points, the graph for the chronometer correction, as determined from the observational data, was plotted to give the rate graph. All outstanding deviations from the plotted graph were re-examined on the records.

The corrections as read from the graph were given to tenths of seconds. In using them, one may interpolate to the required epoch and obtain a correction expressed to tenths of seconds. This permits the exercise of a certain amount of judgment when scaling the time of an event and applying the correction, but the final result should never be quoted to a closer approximation than half a second.

D-4 Distribution of Bursts

Merely to approximate a statistical study of the surface-recorded rockbursts for the period of this report, it would be necessary to have the sensitivity of the seismograph the same throughout or to secure data permitting a comparison; these conditions did not apply. The sensitivity was roughly the same throughout each of the three series: 19/12/1939-31/3/1940 with the original Heiland equipment; April 1 to July 2, 1940 with the mine seismograph on surface; July 3 to Dec. 31, 1940 with the modified Heiland equipment. Inter-comparison of the sensitivity for the three series cannot be made and it is not certain that the sensitivity was the same throughout any given series. Indeed, in the case of Series I it is certain that the sensitivity was falling off after the middle of February. It is to be noted, however, that at no time (except when the gain was inadvertently set at zero, which time is included in the lost time tabulation) was the instrument so lacking in sensitivity that a moderately severe burst would not have been registered.

To overcome this difficulty, it was proposed to provide a simple and uniform mechanical test to be applied to the seismograph each day as a matter of routine. This would show, in some degree at least, the comparative sensitivity of the equipment from day to day.

Another condition that had to be met before the records could be used to show comparative burst activity from month to month was that of routine and regular correlation of underground data as to blasting and other activity with the surface records. Unless this was done promptly and regularly, questions of interpretation would arise when the records were read which could not then be answered.

The reports of bursts for the period of this report may be tabulated on the following basis. In line A are listed bursts sufficiently severe to have a marked duration period (two seconds or more). In line B are listed those less severe, but that could be certainly identified as bursts. In line C are those that were recorded with a notation as to the lack of certainty that they really were bursts.

December 1939 to December 1940

| | Dec. | Jan. | Feb. | Mar. | Apr. | May | Jun. | Jul. | Aug. | Sep. | Oct. | Nov. | Dec. |
|---|------|------|------|------|------|-----|------|------|------|------|------|------|------|
| A | 0 | 1 | 4 | 0 | 0 | 0 | 0 | 0 | 2 | 0 | 3 | 3 | 1 |
| B | 2 | 5 | 2 | 16 | 18 | 5 | 4 | 17 | 24 | 40 | 12 | 24 | 14 |
| C | 4 | 57 | 27 | 28 | 2 | 0 | 0 | 17 | 17 | 18 | 29 | 19 | 21 |

For proper appreciation, this tabulation should be studied in the light of the following notes:

(a) Line A shows 14 fairly large bursts, each of a duration of 2 sec. or more. This is a minumum list; had all records been registered on the original Heiland equipment or even on the final modified Heiland seismograph, the number of larger bursts showing such a duration would undoubtedly have been larger. It should be noted that not a single entry appears in line A for the months April to June, inclusive, when only the mine seismograph with ink registration and low paper speed was in service.

(b) Where the classification was not carefully done, the number of bursts shown in line C probably includes some that should have appeared in line B.

(c) The entries for Series III were determined with the modified Heiland equipment at, presumably, the same sensitivity. While light spot conditions varied and the lost time was not uniform in those months, the conditions were nevertheless more nearly uniform and continuous. The number of records identified as bursts varies from 15 to 40 per month. During this period the scanning of the records at Ottawa was done fairly uniformly, all being read in order without interruption. The number of entries in the three lines combined varies from 34 to 58 per month.

(d) For the last half of 1940, the number of larger bursts ranged from zero to 3 per month and none of these were sufficiently severe to register at Ottawa. The large burst in line A for December occurred on December 28 and at a time when the Benioff at Ottawa was dismantled for adjustment. It was not registered on the short-period instrument at Shawinigan Falls. Previous experience showed that a burst registering at Ottawa also registered at Shawinigan Falls on a slightly smaller scale. It may be inferred that if the burst had registered at Ottawa the amplitude would have been so small as to have precluded the possibility of making a velocity determination.

D-5 Suggestions for Improvement of Service

- (a) The operator should avoid as far as possible the causes of lost time as noted in 1940, and detailed in section D-6.
- (b) Sheets should be replaced on the drum with a minimum loss of time, even though adjustments may be found necessary on developing the sheet just removed. It is better to use an extra sheet than to have the equipment out of use for even a short time.
- (c) When a record covers only an hour or so between two regular sheets, but does so adequately, it should be included in the records sent in evidence of coverage.
- (d) Correlation of sheets with mine data should be noted promptly and regularly, and all offsets on the record should be explained or marked as due to unknown causes.
- (e) Records should be sent to Ottawa regularly once a week.
- (f) Sheets should be time-annotated as soon as they are dry.
- (g) The initials of the operator (or operators) responsible for each sheet should be noted on it.
- (h) All adjustments of the chronometer should be noted on the seismograms. These should be sufficient to enable the chronometer corrections to be determined for the entire record time. If time comparisons were plotted regularly by the operator on a large-scale graph, they would tend to be more accurate, and any changes in rate would show up at a time when the operator might be able to determine the reason.
- (i) Notice should be sent to Ottawa at least one month before the stock of seismograph paper would need replenishing and at least two months before new developer or fixer would be needed.
- (j) It should be borne in mind that any sheet being developed may contain important data that will require copying for use in a report.

D-6 Lost Time Tabulation

In this tabulation, the nearest number of minutes required to change the seismograph sheets each day is entered first, in the appropriate intersection of column and line. Following, in the adjacent compartment for the same day and month, appears the number of minutes lost during that calendar day from various causes as indicated by lower-case letters having reference to the causes listed below. The total and percentage loss for each month are tabulated in the last two spaces respectively of the columns concerned.

- a Adjustments made at record-changing time
- b Light inadvertently turned out
- c Sensitivity dial set at zero
- d Record destroyed in developing
- e Chronometer signals failed
- f Batteries ran down
- g Clutch on lateral drive not set in
- h Clock drum stopped
- i Experimenting with equipment
- j Power supply at mine changed to a new system
- k Ink supply failed (mine seismograph on surface)
- m No record received at Ottawa (no explanation)
- n Pen balance out (pen off paper for some time)
- p Too overexposed to give clear record.
- q Severe electrical storm; power off repeatedly
- r Seismograph being demonstrated to visitors
- s Overlap on adjacent small sheets lost in crack
- t Chronometer ran down for lack of winding
- u Record not changed in time; over-run
- v Light spot too weak to record

Total Lost Time
 33509 min.
 23^d 06^h 29^m

Percentage Lost Time
 6.14 per cent

*

Note:

The original of Report D gave the lost time tabulation as Table I. It is repeated here in full to permit comparison of efficiency of operation of the surface seismograph for 1940, here reported, and for 1941, as given in Report G of this publication.

*

Table 1

| | Dec. | Jan. | Feb. | Mar. | Apr. | May | June | July | Aug. | Sep. | Oct. | Nov. | Dec. |
|----|------|--------|--------|-------|-------|-------|------|------|-------|------|------|-------|-------|
| 1 | | 4 | 2 | 3 | 8 | 3 | 2 | 3 | 3 | | 833g | 1 | 6 |
| 2 | | 185bf | 2 | 4 | 2 | 2 | 3 | 0 | 13 | 2 | 668g | 1 | 1 |
| 3 | | 5 | 2 | 6 | 4 | 3 | 2 | 2 | 150a | 1 | 1 | 20a | 1 |
| 4 | | 644g | 14 | 5 | 4 | 1032h | 2 | 1 | 2 | 3 | 2 | 2 | 7 |
| 5 | | 791g | 2 | 4 | 5 | 3 | 2 | 0 | 4 | 3 | 1 | 1 | 133ms |
| 6 | | 6 | 5 | 5 | 3 | 3 | 2 | 0 | 2 | 3 | 1 | 1 | 1 |
| 7 | | 5 | 8 | 3 | 3 | 1 | 2 | 2 | 4 | 3 | 1 | 435g | 1 |
| 8 | | 6 | 2 | 2 | 410f | 7 | 3 | 2 | 5 | 1 | 5 | 1044g | 2 |
| 9 | | 13 | 2 | 2 | 780f | 5 | 3 | 2 | 1 | 1 | 2 | 2 | 1 |
| 10 | | 5 | 1 | 1 | 327ah | 4 | 1 | 2 | 1 | 2 | 2 | 0 | 1 |
| 11 | | 658g | 3 | 7 | 744h | 4 | 716k | ? | 3 | 2 | 3 | 1 | 1 |
| 12 | | 791g | 3 | 1217h | 3 | 922k | 3 | 2 | 1 | 2 | 2 | 1 | 1 |
| 13 | | 8 | 6 | 4 | 3 | 1 | 2 | 90h | 2 | 5 | 2 | 1 | 2 |
| 14 | | 5 | 2 | 3 | 4 | 0 | 2 | 2 | 31a | 34a | 2 | 1 | 1 |
| 15 | | 6 | 3 | 5 | 3 | 1 | 2 | 1 | 16 | 4 | 3 | 1 | 0 |
| 16 | | 5 | 3 | 2 | 3 | 2 | 3 | 1 | 4 | 2 | 2 | 88u | 11u |
| 17 | | 4 | 2 | 3 | 5 | 3 | 2 | 96n | 1 | 2 | 2 | 1 | 1 |
| 18 | | 3 | 5 | 4 | 658c | 4 | 2 | 2 | 1 | 2 | 2 | 1 | 1 |
| 19 | 7 | 44a | 6 | 2 | 52a | 784c | 4 | 1 | 8 | 1 | 2 | 1 | 1 |
| 20 | 4 | 825abc | 5 | 7 | 3 | 392u | 6 | 671c | 1 | 2 | 2 | 2 | 1 |
| 21 | 8 | | 7 | 4 | 2 | 3 | 3 | 43k | 1410c | 13 | 1 | 0 | 3 |
| 22 | | 765d | 6 | 4 | 3 | 3 | 2 | 62a | 577v | 1 | 26a | 2 | 1 |
| 23 | | 671d | 3 | 3 | 3 | 2 | 3 | 1 | 1213v | 1 | 3 | 2 | 0 |
| 24 | 6 | | 6 | 3 | 2 | 4 | 1 | 2 | 782p | 2 | 2 | 2 | 2 |
| 25 | | 646e | 547h | 8 | 4 | 3 | 2 | 4 | 137q | 1 | 3 | 2 | 1 |
| 26 | | 721e | 8 | 4 | 4 | 223i | 415m | 1 | 617h | 1 | 39a | 18 | 2 |
| 27 | 14 | | 5 | 3 | 1 | 1396m | 2 | 505h | 1 | 1 | 38u | 7 | 76m |
| 28 | 6 | | 2 | 3 | 2 | 3 | 295k | 3 | 191h | 1 | 878g | 2 | 5 |
| 29 | 4 | | 10 | 6 | 239h | 2 | 2 | 2 | 1 | 3 | 487g | 2 | 24 |
| 30 | 7 | | 1356bf | 3 | 2 | 2 | 2 | 2 | 1 | 1 | 11r | 2 | 12 |
| 31 | 6 | | 3 | 44a | 414j | 0 | 2 | 2 | 1 | 1 | 11 | 107m | 2 |
| T | 3734 | 5108 | 119 | 3902 | 2174 | 5221 | 512 | 6150 | 274 | 1574 | 1623 | 1842 | 1276 |
| P | 20.7 | 11.4 | 0.3 | 8.7 | 5.0 | 11.7 | 1.2 | 13.8 | 0.6 | 3.6 | 3.6 | 4.3 | 2.9 |

Report E

Leet Seismograph, Microgauge, and Strain Gauge Results
August 15, 1940, to April 15, 1941

The present report deals with the studies made during the period that has been designated the Interim Program. It presents the results obtained with the Leet seismograph, which was operated at the Frood mine and at Lake Shore, together with the tests made with the Hollinsworth microgauge, and the results obtained from the strain gauge designed and constructed by Gibbs. The last-named was operated in 3001W drift, Sec. 8 from early September, 1940, until a burst on April 8, 1941 wrecked the location and destroyed the gauge. Daily readings of the strain gauge are shown graphically in Figure 34, and discussed in Section E-7.

E-1 Progress Report

At the closing date of Report C, a memorandum had just been presented to Lake Shore Mines recommending among other things the leasing of a seismic prospecting outfit from Dr. L. Don Leet of Harvard University, for the purpose of determining the frequencies of the elastic vibrations in the rock, as generated by bursts, blasts, or other mine noises.

In the meantime, Gibbs constructed a battery-operated amplifier for the mine seismograph, to be used in a long exploratory cross-cut on the 3075-ft. level, running north from the mine proper for more than half a mile. The remote end of this long-disused cross-cut was not supplied with electric current.

The amplifier was completed and installed in the cross-cut (designated 3052 X-C) on August 29. The hydraulic gauge previously constructed was installed in 3001W drift. The routine operation of these and of the surface seismograph was assigned to Butterfield, the new assistant in the rockburst program (see Sec. C-1).

The Leet equipment was tested and installed, and on September 30 was placed in operation. R.G.D. Morrison of Nundydroog Mines, Mysore, India, who had been engaged by the Mining Association to investigate the rockburst situation, was present on this occasion, also Messrs. Yates and Shenon of International Nickel, Professor George B. Langford, head of the Department of Mining Geology, University of Toronto, Mr. Robson of Lake Shore, Gibbs, and the writer. The records were discussed the following day, after which the group dispersed.

It was planned to ship the equipment to Sudbury for experiments in the Frood mine early in October. The cost of leasing and installing the Leet equipment was borne by the two companies.

The Froid experiments were carried out by Gibbs over the period October 8-24. The frequency investigations were carried out at two locations, one on the 2000-ft. and the other on the 2800-ft. level. Considerable difficulty was experienced owing to moisture and acid-charged ground water affecting the equipment, to the practically constant interruptions by mine noises, and to stray electric currents affecting the galvanometers. Good frequency records were obtained after some difficulty, but experiments to obtain rough values of the speed of propagation of the elastic waves through the rock could not be carried out without extensive modification of the equipment. As the instruments were leased, this was out of the question, and the Leet apparatus was returned to Lake Shore Mines on October 25.

Experiments to determine frequency were resumed at Kirkland Lake by Gibbs, assisted by O.E. Andrew of the Lake Shore staff, who had been appointed to assist in this work after Butterfield left Lake Shore early in October. Frequency studies were made again in 3052 cross-cut and also on the 2950-ft. level in a specially prepared location in 2920W cross-cut, close to the west pillar. As the ground was loose, special timbering and lagging were necessary.

The experiments at Lake Shore and Froid showed definitely that:

- (a) Blasting always generated vibrations in the frequency range of about 40-60 c.p.s.
- (b) Some blasts had, superposed on the above low frequency, a higher order of from 200-400 c.p.s.
- (c) The few cases where strain bursts alone registered were found to show frequencies in the higher range only.
- (d) Other mine noises (trimming, hoists, crushers, etc.) generated frequencies of less than 100 c.p.s.

To determine whether the high frequencies could have been due to some characteristic of the equipment, extensive experiments were carried out at Lake Shore. A geophone was subjected to various frequencies controlled by an oscillator and to amplitudes that were kept within appropriate limits. It was found that no high frequencies registered on the seismograms when the geophone was subjected to low frequencies, and that it recorded the high frequencies faithfully as to period, but at a much lower amplification than for the low frequencies.

It was concluded that:

- (a) Blasts generate rock vibrations with a frequency of 40-60 c.p.s.
- (b) Other mine noises generate frequencies of less than 100 c.p.s.
- (c) Bursts generate frequencies of 200-400 c.p.s.
- (d) Blasts in strained rock induce the low frequency and often also release energy that causes the high frequency characteristic of bursts.
- (e) The discrepancy in amplitude of recorded low and high frequencies is due to the non-linear amplification of the equipment. The energy in the burst frequency is relatively greater than the records indicate.
- (f) The high frequencies attenuate with distance much more than the low.

Some attempts were made to determine sound velocities in the rock at Lake Shore but, as at Froot, the difficulties were too great to be surmounted in the limited time available with the leased equipment. Experiments were concluded at Lake Shore on November 19 and the equipment was returned to Harvard.

Filters that would suppress oscillations up to 200 c.p.s. but give good amplification for higher frequencies were finally secured, and were given an exhaustive series of tests. It was found necessary to change the terminal impedance of the filters from 250,000 ohms to 20,000 ohms. Under the new conditions, the cut-off was sharp to 200 cycles and the amplification beyond that frequency was reasonably flat to nearly 5000 c.p.s.

The mine seismograph, equipped with the filter, was set up in the rear of a safety shelter on the 4200-ft. level, where it was operated for some days early in March. This location was not only at considerable depth, but was also in strained ground and close to extensive mining operations. An observer sat beside it several days during blasting time, watching the record while listening to the blasts. It was found that:

- (a) Not all the blasts registered.
- (b) Most of the heavy ones were recorded.
- (c) No records of bursts alone occurred during the observation period.
- (d) Some disturbances, presumably strain bursts, were registered at other than blasting times, and these were usually registered on the surface seismograph also.

It was concluded tentatively that:

- (a) Some of the larger blasts or those nearer the equipment were able to pass the filter simply because of their magnitude.
- (b) Considering the location and its nature, it was probable that most of the blasts released inherent strains in the rock and so generated both high and low frequencies.

On March 15, it was decided to remove the mine seismograph to the surface for the following test. It was set up alongside the surface seismograph and operated first without the filter. Tests were to be made, setting the gain so that both instruments would record with about the same amplitude; the records would thus show both blasts and bursts. The filter was then to be installed on the mine seismograph and the gain stepped up the amount known to be necessary to care for the reduction of amplification due to the filter. The records should then differ if the filter were effective in eliminating blasts in unstrained rock. As many blasts occur in the upper levels of the mine and so, probably, do not release strain, it was confidently expected that the records from the two seismographs would differentiate between bursts (or blasts releasing strain) and blasts not associated with strain.

It was found difficult to get the two instruments to record the same with the filter removed. Tests were finally run on the two geophones to see if they were comparable as pick-ups, and these indicated they were not. Investigation disclosed a friction in the surface geophone. When this was eliminated, the two geophones gave practically the same result under varying tests.

In the intervals between the trial runs, the Leet seismograms were sorted and indexed, those showing no records being discarded. There were hundreds of feet of these obtained at Lake Shore and Frood. Several bursts were recorded, but the bulk of the seismograms had to be discarded.

The time-marking device of the surface seismograph consisted, up to this time, of a shunt which sent a small current through the recording galvanometer for two seconds at the end of each minute. A semaphore arm for eclipsing the light for the timing interval had been constructed at Ottawa. This was installed in such a way that its eclipsing edge divided the recording spot at its zero position. The screen on the lens was removed. The zero position of the spot was set well to the left of the cylindrical lens as viewed from the front of the recording box. The offsets were thus all to the right (downward on the sheet) but could use the full width of the lens instead of only half as before. The time impulse shifted the semaphore to the left, making a mark upwards. The time marks were thus on the opposite side of the record line from the recorded burst and blast offsets.

The changes in the optical system required many adjustments to the surface seismograph equipment. The comparisons between mine seismograph and surface seismograph were hardly begun when, on March 23, Hollinsworth arrived with his microgauge and equipment. The comparison experiments were postponed indefinitely while part of the mine seismograph was taken over for use in the microgauge experiments.

Microgauge and Strain Gauge Tests

Hollinsworth had been experimenting during the late summer of 1940 with an electric gauge for rapid testing of machined parts. The device is very sensitive, showing a deflection of about a quarter of an inch on the meter for a movement of 10^{-5} inches at the gauge. It was suggested that such a gauge might yield valuable information if designed to be placed deep in a diamond drill hole run into a pillar to reach the pressure zone of a dome.

The gauge, redesigned by Hollinsworth with this object in view, was the subject of experiments by him at Ottawa from early November to the middle of March. At Ottawa the power supply is 60 cycles and the voltage fluctuations were not severe. The gauge was made quite stable for experiments at Ottawa.

The power supply at Lake Shore was 25 cycles and the voltage fluctuations severe. Moreover, there was no certainty that the bore hole, only 1.5 in. in diameter, would be deformed appreciably by pressure. For these reasons it was felt that experiments should be carried out at the mine.

The equipment was set up in the laboratory at Lake Shore on March 24. A block of rock about as large as a football had a standard diamond drill hole bored in it. It was found that pressure on the rock with the hand alone would deform the bore hole sufficiently to cause a marked deflection on the meter. Pressure in the direction of the line of contacts of the

gauge indicated a shortening of that axis of the hole; pressure at right angles showed the same axis to lengthen. There was no longer any doubt that the bore hole might be deformed by comparatively slight changes in pressure.

The change to 25 cycles necessitated changes in the gauge. Experiments were run in the laboratory for several days. While these were in progress Gibbs arranged equipment, utilizing the Esterline-Angus meter of the mine seismograph for recording the meter readings continuously. A special horizontal diamond drill hole 20 ft. deep was made in the rock at the observing station in the rear of the safety shelter on the 4200-ft. level. The device was taken into the mine and no difficulty was experienced in clamping the gauge at any desired depth in the hole, but the voltage fluctuation was found to be unusually severe.

A special supply line was run to the station in an effort to avoid the circuits most affected, but the trouble was still much too great to permit the operation of the gauge. After more than a week of experiment, it was decided that a commercial voltage regulator would be required. Enquiry showed that this would cost about \$200 and could not be promised for less than five weeks after order. For the gauge to operate continuously an extra Esterline-Angus recorder was also needed, or the mine seismograph routine would be interrupted. This would cost upwards of \$300. It also would require several weeks for delivery.

On being advised of the situation, Mr. Blomfield at once authorized the purchase of the two instruments. It was agreed that the gauge should remain at Lake Shore and that Gibbs should experiment with it in the laboratory with a view to achieving the necessary constant power supply and to ironing out other difficulties connected with continuous registration. A second gauge was to be made at Ottawa to be used by Hollinsworth for obtaining pressure-strain curves of large samples of rock, bored at the mine and supplied for these experiments. The blocks, after being sawn into regular form and lapped, would be subjected to pressures applied by a hydraulic press and carried to the point of failure of the specimens.

Three specimen rocks, two of syenite and one of porphyry, were received at Ottawa about the middle of April, to be sawn and lapped at the Bureau of Geology and Topography and tested at the Bureau of Mines.

It was planned to resume underground work at Lake Shore as soon as the equipment was ready, and it was expected to produce interesting data of a local character. Steps were also taken towards developing equipment for detecting and recording supersonic vibrations in pillars. This line of investigation also was considered most promising and might yield data of a local character, since the short wavelength of the vibrations would result in their rapid attenuation with distance.

The hydraulic strain gauge, described in section C-5, was installed in section 8 of 3001W drift on September 1, 1940. Deep holes were drilled on opposite sides of the drift, in which thrust rods were set with the gauge between them. Thus the convergence (or divergence) of the walls behind the loose rock was made the subject of study.

Daily readings obtained from this gauge are shown in Figure 34. It will be noted that, after a period of about two weeks during which, it may be presumed, the lost motion in the connections was being taken up by convergence, the graph drops down from the broken line drawn at an angle of approximately 38° with the axis of abscissae and rises again to meet that line at the time of the large burst on January 19, 1941. This burst was close to the gauge, affecting among other places the adjacent section 7 of 3001W drift. It may be argued with some reason that the broken line represents the average rate of convergence of the drift and that, when the actual convergence rate was less, strain was building up, leading toward another burst in the vicinity. Some other bursts, more distant from the gauge but still in the same general area, are shown to have little or no effect on the displacement of the graph from the average line.

The graph falls again after the January burst to the last reading on April 7. On April 8, there occurred a large burst that involved section 8 of 3001W drift, and the gauge was buried in fallen rock.

E-2 Experiments at Lake Shore Mines with Leet Equipment

After two days of assembling and testing in the laboratory, the seismograph was installed on the 3075-ft. level a little north of the Lake Shore boundary, as shown on Figure 27. Three of the galvanometer tracks were used for pick-ups: an SSC geophone, the spare Heiland geophone, and the Brush crystal detector. The natural frequencies of these were, respectively: 38 c.p.s., 20 c.p.s., and 1-5000 c.p.s.

The spare geophone line was used for signalling by means of small currents sent through its galvanometer. A telegraph key was used by one observer to note, by deflections of the signal record line, the occurrence of certain observed noises regarding which notes were made by another. It was found difficult to make the closing of the key sufficiently short to give a definitive signal. After the first few experiment periods the method was abandoned.

The experiments were carried out during blasting time. In a few cases only, the air wave penetrated to the observation point and registered, especially on the line from the crystal pick-up. The frequency of such waves was very low, about 20 c.p.s. (see Figure 29e) and the amplitude high.

All the blasts registered with frequencies of from 40 to 60 c.p.s., but in some cases frequencies of from 200 to 400 c.p.s. were registered. These higher frequencies occurred sometimes right at the beginning of the shorter frequency series, sometimes from .08 to .11 sec. before, and also right at the beginning. In a few cases, a high frequency registration occurred when there was no blasting; in others, the frequency characteristic of blasting had no high frequency imposed on its initial swings. The low frequency usually decreased slightly after the first few swings.

Samples of records made in Lake Shore Mines during this period are given in Figures 29 and 30. The description of these is as follows:

- 29a Record No. 47 (LS)
Small burst with no blast frequency. Some interference from 50-cycle tuning fork.
- 29b Record No. 82(F)
Burst superposed on blast.
- 29c Record No. 21(LS)
High frequency .10 sec. before blast frequency and also at the beginning of the blast.
- 29d Record No. 42(LS)
Same as Figure 29c except that the lag of blast frequency is only .08 sec.
- 29e Record No. 38(LS)
Air wave from earlier blast, with high frequency preceding a blast by .10 sec.
- 29f Record No. 75 (F)
Blast showing high frequency missing. Note lag of successive records owing to spacing of pick-ups.
- 30a Record No. 94(F)
Showing effects due to tramming.
- 30b Record No. 111(F)
Showing effects due to the crusher.
- 30c Record No. 87(F)
Showing effect of pulling chutes.
- 30dd Record No. 86(F)
Showing effect of a drill in a nearby stope.
- 30e Record No. 140(LS)
Record made by impressing disturbance on geophone of 2 c.p.s.
- 30f Record No. 146(LS)
Record made by impressing disturbance on geophone of 54 c.p.s.

E-3 Experiments at Frood Mine with Leet Equipment

The observations were discontinued at Lake Shore after about a week. The equipment was taken to Sudbury, and experiments began at the Frood mine on October 9 and continued until October 24. The first set-up was made in a special observing room on the 2800-ft. level which had been converted from a powder magazine to a seismograph station. This room was adjacent to a travelled cross-cut, and there was considerable disturbance from passing trams and electric locomotives. Stray electric currents affected the galvanometer circuits and acid-charged water tended to short the cable.

Small strain bursts are relatively frequent in the Frood mine, and it was expected that good records would be obtained of a burst, showing its vibration frequency. The disturbances were so great, however, that daytime observing was abandoned. Conditions at night were much better, and some good records were obtained at this first location.

It was decided to attempt some velocity measurements while the equipment was in a section of the mine best suited for such investigations. Blasts could be set off about 2000 ft. distant and the development drifts provided a convenient path for the connecting cables.

Experience showed that the equipment could not be used for this work without considerable modification: this was out of the question, as the instruments were on lease. The only velocity value obtained was 12,120 ft./sec. This is of the order to be expected, but the doubtful values of the basic data render it quite uncertain. The velocity determinations were made difficult by electrical interference on the connecting cables and by the difficulty experienced in getting sufficient energy from the blasts without throwing down a prohibitive quantity of muck. One blast of three sticks at 2000 ft. brought down about 10 tons of muck into the drift and failed to register on the geophones.

Attempts to continue velocity experiments were finally halted when the acid-charged water in the drift attacked the cables and necessitated a complete overhaul of the outfit. It was decided to move to the 2000-ft. level, where a set-up was made between manways 27.25 and 27.75 in a narrow travelway about 30 ft. above the drift. The geophones were placed on solid rock and set with plaster of paris.

Interference here was much less. There were many more small strain bursts in the immediate vicinity, and numerous good records of both blasts and bursts were obtained. The average low frequency obtained from all the Frood blast records was 60 c.p.s. The average for the high frequency was 272. The average for the frequency of vibration of small, known, isolated strain bursts was 223 c.p.s.

E-4 Testing Experiments with Leet Equipment

The very definite recording of two groups of frequencies raised the question as to whether the higher values might not be due to some resonance characteristic of the equipment. The arguments against such a conclusion were: (a) pick-ups of different natural frequencies recorded, and rapid movements at essentially the same frequency, though with different amplitudes: (b) at times the high frequencies occurred when no blasting was recorded, while at other times blasting frequencies alone registered. (c) the character of the records, made with the same equipment but in different mines, differed somewhat in the frequency values and also in the relative positions of the two frequencies. Experiments impressing various known frequencies on the equipment were carried out, and in every case the recording showed the same frequency as that impressed on the pick-up. Two samples of such records are shown as Figures 30e and 30f, the first being in the nature of a series of sharp impulses, and the second approximating the average blast frequency.

E-5 Final Experiments at Lake Shore with Leet Equipment

The final experiments at Lake Shore Mines were designed to secure records made during blasting time, velocity records, records of typical disturbances, and records made in off-shift periods.

The blasting time records were made on the 2975-ft. level in a specially constructed shelter in 2920W, and also in the long cross-cut, 3052W, where the equipment was simply wheeled into place on a small mine car. The results agreed entirely with those reported in the preceding sections.

Attempts at velocity records were made on the 1000-ft. level and also on the 4000-ft. level. The same difficulties were encountered as at Frood, and no records of any value were obtained.

Records made of typical mine noises (see Figure 30) due to tramming, drilling, chute-pulling, etc. were similar to those obtained at the Frood mine. In no case were mine noises of frequencies higher than those of blasting, except those caused by the drill. Here the frequency was of the order of 250 c.p.s. Drilling did not register, either on the Leet equipment or the mine seismograph, unless it was taking place very near the set-up, usually in the adjacent stope.

Making records in off-shift periods was a little like trying to secure a moving picture of a street accident by repeatedly taking short shots of a busy corner. The operator entered the mine soon after blasting time, when small strain bursts are most common, and ran sections of record paper at intervals. Notes were made for each section as to what noises were heard and at about what part of the record. Several small strain bursts were registered in this way and one rather severe one at a little distance. The frequencies obtained from these were always high. The method was adopted as an off-chance means of obtaining useful data and using up the remainder of the photographic paper before the lease period expired. It entailed a great deal of work in developing the many feet of paper, scanning it in connection with the notes, and picking out the few useful sections.

The Leet seismograph was shipped back to Harvard on October 25.

E-6 Filter Designed for Mine Seismograph

Accepting the deduction from the experiments outlined above, that there is a wide difference in the frequency range of blasts and bursts, it became desirable to secure for use with the mine seismograph a filter that would reject pure blast frequency and accept that of bursts, either alone or released by blasting.

The design and construction of these filters was referred to General Radio Corporation of Cambridge, Mass. Because of the pressure of defence work, they were unable to supply the filters without very considerable delay. However, they kindly furnished the specifications for their construction, and the filters were made, with very little delay, by the Hammond Manufacturing Co. of Guelph, Ont. On being tested they were found to require some modification of their terminal impedances. When these were corrected they gave a very satisfactory cut-off to a little below 200 c.p.s.

The mine seismograph operated from about February 25 with this filter in circuit. It was tested at various positions in the mine and was found to reduce the number of registrations of blasts; at some locations, however, it passed so many that it was difficult to believe that such a large percentage of blasts could be coupled with induced bursts.

Experiments carried somewhat beyond the time range of this report have finally shown that, when the seismograph with its filter was located in the 3052 cross-cut, it recorded all the known strain bursts very definitely, and only about 5 per cent of the blasting, when set at 2.5 decibels attenuation.

The record from the mine seismograph under these circumstances showed all bursts of any importance, and so few of the blasts that it is safe to conclude that these registered blasts were accompanied by a release of strain. The location was at the extreme end of the 3052 cross-cut, and the record under these conditions may be taken as a measure of the release of strain in the mine.

E-7 Record of the Hydraulic Strain Gauge

The hydraulic strain gauge, designed and constructed at Lake Shore by Gibbs, was installed early in September 1940 in 3001W drift, section 8, a particularly unstable part of the workings.

The gauge consisted of a heavy brass cylinder with an internal diameter of about an inch. This was closed at one end by a piston working through a packed sleeve. The other end opened into a glass tube at right angles to the brass cylinder. The ratio of areas of internal cross-sections of the cylinder and tube was found to be 12:1. The liquid used was a coloured oil.

Two holes were drilled opposite to each other in the walls of the drift to a depth of about six feet — well within the spalled surface. Into these were thrust two iron rods that transmitted the pressure of the walls to the cylinder and piston.

The daily readings of the gauge are shown graphically in Figure 34; the gauge itself is shown in Figure 22. The various numbers written above the graph indicate bursts that occurred near the strain gauge. The location of these in the order in which they occurred is given below. The letter 'C' after a burst number indicates a crush type. The time of each is

roughly indicated by the position of the dot associated with each number on the time scale of the graph.

| No. | Cross-cut or Drift | Sec. | Rock Fall in Tons | Class |
|------|-----------------------|------|----------------------|--------|
| 221C | 3301W : | 10-1 | 10 | Light |
| 223C | 3001W : | 10 | 10 | Light |
| 224C | 2801W : | | * | Medium |
| " | 2819X : | | * | " |
| " | 2918X : | | * | " |
| " | 2901W : | | * | " |
| 225C | 3301W : | 10-1 | 10 | Medium |
| 230C | 3301W : | 8 | 45 | Light |
| " | 3301W : | | 10 | " |
| 231C | 3401W : | | 5 | Light |
| " | 3413X : | | 1 | " |
| " | 3401W : | | 20 | " |
| 288S | 3001W : | 10 | 5 | Light |
| 236C | 2901W : | 9 | 20 | Medium |
| " | 2901W : | | 50 | " |
| " | 3001W : | 7 | 10 | " |
| 237C | 3001W : | | 80 | Light |
| 238C | 3401W : | | * | Medium |
| " | 3501W : | | 100 | " |
| " | 3701W : | | 12 | " |
| " | 3701W : | 14 | 5 | " |
| 240C | 3202W : | | 25 | Heavy |
| " | 3301W : | | 200 | " |
| " | 3301W : | 10-1 | 8 | " |
| " | 3401W : | | 20 | " |
| " | 3401W : | 9 | 30 | " |
| 241C | 3301W : | | 40 | Heavy |
| " | 3202W : | | 50 | " |
| " | 3301W : | | 35 | " |
| " | 3301W : | 7-2 | 30 | " |

* Damage confined to timbering.

It should be noted that some 'light' bursts displace more muck (broken rock) than do those designated as 'medium'. For example, 225C is marked medium, but displaced only 10 tons, while 237C, a light burst, displaced 80. That is to say, the intensity of the burst is not measured by the amount of rock thrown down, but by the general evidence of violence, including the shock as noted by the miners underground and on the surface.

It may be assumed that, after a period during which the closure was taking up lost motion in the gauge set-up, the broken line on the graph shows the average closure on the gauge. Where the actual closure fell away from the average, it was brought back by a large burst (236C). The light burst of early November (230C) was two levels below the drift in which the gauge was set, and apparently caused a slight return to the average. The medium bursts of mid-October (224C, 225C) were in the vicinity, one above and the other below the gauge location, and appear to have caused the graph to trend upward from the average slope. On the other hand, the light burst of early February (237C) had no apparent effect.

The graph, after late January, was below the average line. On April 7, 1941, the date of the last reading of the gauge, the trend was still downward from the broken line. On April 8, a large burst involved section 8 of 3001W drift, the location of the gauge. The gauge was buried in the muck and was not recovered until some weeks later.

Though this series of observations was neither long enough, nor repeated in a sufficient number of places, to warrant definite conclusions, the results seemed to indicate that the closure is variable, that it may be detected by such a gauge, and that a slowing up in closure indicates the building up of pressure that creates conditions favourable to a burst in the region under investigation.

Report F

Microgauge Experiments at Ottawa

May-June 1941

These experiments were arranged by Hollinsworth, who collaborated throughout the entire range of the experiments and assisted in the preparation of the data for this report.

The experiments were undertaken to determine the behaviour of drilled specimens of Lake Shore rock under pressure. It was realized that the conditions for rock in place could not be duplicated. At depth, rock pressure is pseudo-hydrostatic. Even when excavations have been made, only a part of the surface of a pillar is exposed. In the laboratory, with the time and means available, it was possible to employ unilateral pressure only. However, it was felt that the experiments should be attempted, in the hope that some leading ideas might emerge on testing with a microgauge the deformation of a diamond drill hole in a prepared specimen of mine rock as the pressure was gradually increased to the bursting point.

F-1 Preparation of Specimen Rocks

One specimen of porphyry and two of syenite, each with a 1.5-in. diamond drill hole, were supplied in the form of rough blocks weighing upwards of 75 lb. each. The porphyry specimen showed some signs of jointing; the others seemed quite solid. It is very difficult to secure solid specimens of this size at Lake Shore. The syenites are designated S₁ and S₂; the porphyry specimen is indicated throughout this report by the symbol P.

Each block was sawn into a cube of about 5-inch sides, so that the drill hole lay symmetrically along the line joining the centre points of two opposite sides. Two opposing planes parallel to the axis of the drill hole were selected and lapped to smooth surfaces.

Arrangements were made to use the Bureau of Mines (now the Mines Branch) hydraulic testing press. The prepared specimens were checked on being received and as specimen S₂ was found to be not as well surfaced as the others it was capped for the pressure tests.

As prepared for the tests, the specimens had the following areas on the faces to be subjected to pressure: P, 21.0 sq. in.; S₁, 20.3 sq. in.; S₂, 26.6 sq. in.

The drill hole effectively reduced these areas by an amount equal to its projection on the pressure plane. The areas sustaining pressure thus became: P, 14.2 sq. in.; S₁, 13.8 sq. in.; S₂, 19.1 sq. in.

F-2 Preliminary Crushing Strength Tests

In order that the crushing strength of the rock might be known approximately, permitting removal of the gauge shortly before the specimens were likely to burst, cylinders two inches in diameter and two inches long were cut with a core drill from some of the larger pieces sawn from the large syenite rock to reduce it to regular form. These test cylinders, three in all, were carefully capped and then crushed in the press. The pressures at which the test cylinders broke were: 37,800, 38,800, and 32,200 pounds per square inch.

F-3 Behaviour of Specimens under Pressure

The behaviour of all three specimens under pressure was substantially the same. Up to about 250,000 lb., depending on the specimen, the difference in pressure for a unit of compression was, within the errors of observation, apparently constant. That is to say, the diameter of the drill hole that was perpendicular to the plates of the press shortened linearly as the pressure increased.

At about 250,000 lb., the pump control being left unchanged in its setting, the pressure dial would show a falling off in pressure, sometimes accompanied by a cracking noise, while at the same time the milliammeter pointer moved rapidly in a positive direction, showing that the hole was closing. The specimen was yielding, compressing the hole and reducing the pressure between the plates of the press in spite of the steady slow pumping in of oil.

These observations were qualitative only. The amount by which the block as a whole yielded and the amount by which the diameter of the hole was reduced could not be measured. Indeed, at the first sign of such a reversal of pressure, the gauge was unclamped as quickly as possible. In no case was the gauge injured by this yielding, initially sudden and followed by a gradually attenuating diminution.

After the pressure dial again began to move positively, with the controls as they were, the gauge was reclamped and a unit compression reading taken. The initial reading was sometimes as low as 400 lb., but the second and successive readings, as the pressure was gradually raised some thousands of pounds, were of normal value, showing that the rock was, apparently, as strong as before.

At a higher value another sudden yield occurred, and the above cycle was repeated. In some cases as many as four yield points were passed before the pressure was so near the probable bursting value, as indicated by the test experiments with the cylindrical samples, that the gauge had to be removed from the hole. Throughout all the regular compression, including the yield points, the hole was never compressed so much that the available adjustment on the jacking device of the gauge would not permit its ready removal. This available range was about .02 in., and the total yield of the hole was thus of the order of .01 in. This is of no particular importance except for the indication that the design of the clamping device was satisfactory for conditions likely to occur in practice in the mine.

Figure 39 indicates the course of the experiments as described above. The position of the yield points, the loss in pressure at each, and the final bursting pressure are taken from the test of specimen S_1 . The slope of the compression is of the same approximate value for all the specimens. The amounts and rates by which the compression increased during the yield periods are not known; hence the dotted lines in these sections of the graph.

F-4 Observations on Figure 39

This graph indicates, qualitatively rather than quantitatively, the behaviour of the small syenite specimen S_1 . The series of determinations of the differences in pressure for a unit of compression indicated that the variation was linear. The slope selected for the unbroken lines of uptrend is quite arbitrary. It was approximately uniform, however, throughout the experiment.

At 150,000 lb., a tension crack opened above the centre of the hole. In spite of a continued slow input of oil to the press, the pressure fell, indicating that the block, and therefore the hole, was yielding. The amount of the pressure-fall and that of compression not being known, the slope of the broken, down-trending lines was not determined. This slope was arbitrarily chosen. It may not have been uniform for any one instance and many have differed for different parts of the graph. The specimen yielded several times in this 150,000-lb. region, but terminal pressure values were not defined. Hence the faint terminations made in drawing the otherwise solid lines.

The block yielded several times in about the same pressure range, and in each case resumed its former strength. This strength was then maintained from little over 160,000 to about 270,000 lb. At this point several cracks opened, with temporary resumption of strength in the intervals.

The experiment was discontinued during the lunch hour, the pressure being left on at 272,000 lb. What change occurred in compression is not known, but, on resuming the experiment, the press dial read 266,000 lb.

A series of yield points followed, after which the rock again became, apparently, as strong as before. At 350,000 lb. the gauge was removed from the hole and the control valve set to slowly build up pressure.

At 364,000 lb., the pointer on the press dial wavered, stopped, and then began to move in reverse quite rapidly. As it reached 340,000 lb., the specimen broke with great violence. It then appeared as in Figures 36 and 37. Note the multiple fine lines of shear in otherwise solid wedges, as shown in Figure 37.

F-5 Character of the Specimens after Yielding

After the porphyry specimen had been subjected to pressures up to 130,000 lb. it suddenly yielded but did not burst (Figure 38). It was removed from the press and taken to the Observatory to be examined. The jointing due to pressure is quite marked and a spalled line along the inside of the hole is clearly shown. The block, however, was evidently quite strong for, on being returned to the press, it showed about the same resistance up to 257,000 lb., when it again yielded. It then recovered its normal strength and withstood increasing pressure. It finally burst at 294,000 lb.

The porphyry specimen was not as strong as the syenites, but this was, in part at least, owing to the fact that it was visibly jointed. One of these joints opened as a slab was cut from the rough block.

The large syenite specimen, S₂, was capped and the plates of the press were oiled to reduce lateral friction. The other specimens were left dry. In every case, a piece of cardboard was used above and below, between the block and the plates of the press. Prior to 510,000 lb. pressure, the specimen had yielded only once. It snapped at 505,000 lb., and the pointer on the press dial fell to 462,000 lb. before the specimen again resumed its normal resistance to compression. At 510,000 lb., it snapped again. It was removed and taken to the Observatory. The block showed one tension crack above the hole and two below. When returned to the press this block burst at 590,000 lb.

The small syenite specimen, S₁, showed the greatest number of yield points. The energy with which it burst was markedly greater than that of either of the others. The specimen burst at 340,000 lb., after sustaining pressure up to 364,000 lb.

F-6 Tabulation of Experimental Data

| Specimen | Net Area | Bursting Pressure | Pressure per sq. in. |
|----------------|----------|-------------------|----------------------|
| | sq. in | lb. | lb. |
| P | 14.2 | 294,000 | 20,700 |
| S ₁ | 13.8 | 364,000 (?) | 26,400 |
| S ₂ | 19.1 | 590,000 | 30,900 |

The cylinders cut from the slabs sawn from S₂ were, presumably, freer from incipient joints than the large regular block made from the same rough rock. The average of their crushing strengths was found to be 36,266 lb./sq. in. which is a value in fair agreement, all things considered, with the last value in the final column above.

Without doubt, the crushing strength of the rock in the mine, subjected to semi-confining pressures, is greater than this value and the compression/pressure ratio is less.

F-7 Conclusions

The following conclusions seemed warranted, even though the conditions of the experiment differed so greatly from conditions in the mine. The fact that the results of the experiments were qualitative rather than quantitative seemed unimportant in the circumstances. Some of the conclusions outlined below would have been evident from a priori considerations, but they were emphasized by the experiments.

It was concluded that:

- (a) The gauge as at present designed was more sensitive than required. A reduction in sensitivity would result in a marked gain in stability.
- (b) The range of the clamping device seemed to be sufficient.
- (c) The graph of Figure 39, showing the typical behaviour of a prepared block under unilateral pressure, could not be considered any indication of the behaviour of rock in place under confining pressure.
- (d) It was unlikely that the gauge would be damaged by any strain short of actual crushing.
- (e) The fact that the behaviour of blocks under unilateral pressure was essentially the same suggests that the law of consistent behaviour may be determined for rocks under pressure at the mine.
- (f) The lines of spalling in a drill hole are 90° from the axis of compressive stress.
- (g) Tension cracks in a drill hole indicate the axis of compressive stress.
- (h) It is not likely that a pillar will crush under pressure before ample warnings have been given by sudden yieldings in its component blocks. Some of these take place long before crushing conditions are reached.
- (i) The syenite specimen had a specific gravity of 2.81. Presumably, the average mine value would be about 3. Thus, on an isolated pillar under homogeneous rock, the pressure would be 1300 lb./sq. in for each 1000 ft. in depth. The small test specimens were crushed at from 32,000 to 39,000 lb./sq. in., corresponding, roughly, to depths of from 25,000 to 30,000 ft. Confining pressures would probably render rock stable at even greater depths. Faulting and other departures from uniform conditions, so prevalent in the mine, explain failures at lesser depths. These considerations are in accord with previous conclusions from seismic recording of bursts that pressure of overburden alone is sufficient to account for these failures.
- (j) As rock under unilateral pressure after yielding becomes as strong as before, this is even more likely to be the case for rocks under mine conditions.

(k) A pillar bursts because of partial relief of confining pressure. That is to say, it bursts from a combination of confining pressure and resultant unilateral pressure. The former tends to increase the strength of the rock prior to bursting, but contributes to the force of the burst when it comes. Because of the resultant directional pressure, the drill hole in the mine will go out of round under conditions tending to favour bursting.

(l) To detect the conditions developing at a given point in the mine two gauges, measuring compression in two directions at right angles, should be used. Preferably at least two such pairs should be set at different depths in the same hole. Similar quadruple set-ups should be employed near the middle of the arch of a dome and also near the abutment on the smaller pillar end. The gauges in the centre of the dome should be set in at a considerable depth — well within the zone of compression. Those near the pillar should be just within the zone of spalling. Eight gauges, as suggested above, could be arranged to record through a single amplifier etc., and possibly on a single recording meter.

*

Report G

Kirkland Lake Seismograph Records

1941

G-1 Summary Discussion

The seismograph and auxiliary equipment were modified considerably during 1940, resulting in a recording time loss of 6.14 per cent (see D-6). Few changes were made in 1941 and these did not seriously interrupt the recording. The time loss in 1941 was only 3.08 per cent. At no time was the time correction unknown, and for most of the year the adjusted corrections were classed as 'A', i.e. dependable to within $\pm .5$ sec. As a result, except for the time losses set forth in Table A, the check on rockbursts at Lake Shore was continuous. It is known that no burst of any importance occurred during any of the interruptions to service.

Only two bursts (those of July 30, listed as No. 255C in Table D) were of sufficient magnitude to register on the Benioff seismograph at Ottawa. The data obtained permitted a fairly precise determination of seismic propagation time to Ottawa and a less accurate value to Shawinigan Falls. The burst was not registered at Seven Falls or at any of the New England stations.

The correlation of mine data and instrument records for 1941 was most satisfactory. The detailed reports on all bursts at Lake Shore were made available regularly to the writer in Ottawa as well as to those working at Kirkland Lake. The correlation was most carefully done by O.E. Andrew of the Lake Shore staff, and the seismograms were subjected to close scrutiny throughout the year. In some cases, bursts were reported at Lake Shore that were not registered on the seismograph; others, not listed, appear on the records.

The first group, bursts listed but not registered by the surface seismograph, includes more or less important rock falls with or without slight shocks to start them. It is readily understandable that during the off-shift periods (in general from 3 a.m. to 7 a.m. and from 3 p.m. to 7 p.m.) the blasting immediately preceding many have loosened some rock masses and that very slight bursts may suffice to cause rock falls of several tons. Such slight strain bursts may not have released sufficient energy to register on the surface seismograph, approximately a quarter of a mile distant.

Bursts in the second group, those registered but not listed, are usually more severe. They may occur in abandoned workings of Lake Shore Mines, or in adjacent mines. A few of them were identified as having occurred in other mines, but no regular reports from those mines are available. If such a burst were of sufficient magnitude to register at Ottawa it

could, no doubt, be definitely located and the data could be used for velocity determinations. In the meantime, the surface seismograms indicated all these relatively severe releases of energy and provided a complete record of the burst activity in the vicinity of the installation. The records were of sufficient value to warrant a recommendation that they be continued at their present standard throughout 1942.

G-2 Lost Time

The importance of maintaining the surface seismograph in continuous, efficient operation was emphasized in Report D. An analysis of the time lost during 1941 showed a marked improvement over the results for 1940, the lost time being reduced from 6.14 to 3.08 per cent.

A further reduction would result if automatic signals were installed to warn of the failure of the light source; the time lost from such failures in 1941 was 5866 min. out of a total time loss of 16,168 min. Had all light-source losses been avoided, the lost time for 1941 would have been reduced to 1.96 per cent.

G-3 Distribution of Bursts

The continuity and uniformity of recording in 1941 was much better than in 1940. Installation of the testing device on Aug. 4 provided a check on the uniformity for the remaining part of the year. Previously, the recording of the daily blasting was the only proof of continued sensitivity. It seems certain, however, that all bursts of sufficient intensity to be of any interest in this investigation were registered.

The mine seismograph was not operating continuously during the year. When its records were available they were scanned in conjunction with those of the surface instrument and the mine reports. Some, but not all of the bursts reported but not registered at the surface were found to have been registered on the mine seismograph.

The mine reports are listed in G-4. Of the 77 bursts reported, 50 were recorded by the surface seismograph and 19 were not; five may have been recorded, but the record is not certain; one could not have been recorded as the seismograph was not operating when it occurred, and two others may have failed to record for the same reason.

Of the 19 that did not record, only three were in the more distant (eastern) end of the mine; the recording of one other burst that occurred in that end is also open to question. It does not appear, then, that the greater distance is a serious factor in the explanation for non-recording of some reported bursts. Of the 77 bursts reported, 20 occurred in the eastern end of the mine.

In the tabulation below, the seismograph records have been divided into four categories on the basis of the range in half-millimetres of the half-amplitudes on the records as made by the bursts — A, half-amplitudes up to 10; B, 11-20; C, 21-30, D over 30. The fifty bursts certainly recorded fall into the categories as follows: A-12; B-15; C-5; D-18. The tabulation gives the analysis of all records obtained by the surface seismograph.

| | A | B | C | D | Total |
|--------|-----|-----|----|----|-------|
| Jan. | 15 | 3 | 2 | 1 | 21 |
| Feb. | 9 | 6 | 3 | 2 | 20 |
| Mar. | 7 | 7 | 2 | 2 | 18 |
| Apr. | 6 | 14 | 4 | 3 | 27 |
| May | 7 | 6 | 5 | 0 | 18 |
| June | 12 | 11 | 3 | 0 | 26 |
| July | 29 | 10 | 9 | 0 | 48 |
| Aug. | 9 | 9 | 2 | 5 | 25 |
| Sep. | 16 | 10 | 0 | 6 | 32 |
| Oct. | 17 | 15 | 1 | 9 | 42 |
| Nov. | 6 | 6 | 1 | 8 | 21 |
| Dec. | 1 | 4 | 0 | 3 | 8 |
| Total: | 134 | 101 | 32 | 39 | 306 |

There is a noticeable increase in the number of the largest bursts (D category) after August 1. After November 17, when a strike began and production was curtailed, the number in this category was only two and for December three. All categories fall off noticeably after November 17.

The total number of bursts reported by the mine or recorded on the surface seismograph in 1941 was about 325. If we deduct most of those in category A, many of which are of the order of the largest blasts, we may say that at least 200 bursts of considerable intensity occurred during 1941, although it does not follow that all of these occurred in the Lake Shore mine.

G-4 Larger Rockburst Located and Listed by Lake Shore Mines

This list of rockbursts was given in the original report as Table D. The disturbances are classified as strain and crush bursts and the latter are further subdivided into heavy, medium, and light. The distinctions are not sharply defined. It is believed that a strain burst simply releases strain in the rock; it may, however, cause rock slides, or sections of the surface of the workings may spall off. A crush burst, on the other hand, is one in which the rock of a pillar is completely broken down. The terms heavy, medium, and

light are based on the estimates of the miners and are derived from the integrated impressions given by the noise and shock experienced and the damage done. There are no precise criteria. The terms were not used in the reports received at Ottawa until after the end of March.

In the tabulation, the strain or crush bursts are combined into one chronological series. The numbers followed by S indicate strain bursts; those followed by C are crush bursts. The table shows the serial numbers of the S and C series, as given by the mine records, the date, the Eastern Standard Time as reported by the miners, a rough indication of the location, and an estimate of the number of tons of rock displaced. The mine reports give many other details that cannot be included here, and are accompanied by plans and elevations of the sections of the mine effected.

The capital letters, H, M, or L, appended to a C-serial number in the first column indicate respectively a heavy, medium, or light burst, as 243C-H. The capital letters elsewhere in the columns refer to a key given at the end of the tabulation.

Larger Rockbursts Located and Listed
by Lake Shore Mines

| No. | Date | Time | Location | Tons | Remarks |
|-------|---------|------------|------------------|------|----------|
| 292S | Jan. 4 | 1:15 p.m. | 3901W | 2 | Recorded |
| 293S | " 16 | 8:15 p.m. | 4301W | - | No trace |
| 294S | " 18 | 10:50 p.m. | 3202W) 3314W) | 2 | Recorded |
| 295S | " 18 | 1:30 a.m. | 3018W) 3202W) | 9.5 | A |
| 236C | " 19 | 12:25 p.m. | 2901W | - | B |
| 296S | " 21 | 10:00 p.m. | 4001W | - | Recorded |
| 296S+ | " 26 | C | 817E | 70 | Recorded |
| 297S | Feb. 6 | 8:05 p.m. | 3701W | 5 | Recorded |
| 237C | " 12 | D | 3301W | 50 | Recorded |
| 238C | " 13 | 10:24 a.m. | 3501W | ? | Recorded |
| 239C | " 17 | ? | 4202E | ? | Recorded |
| 298S | " 17 | 9:15 a.m. | 3214W | 1 | No trace |
| 240C | " 18 | 4:00 p.m. | 3401W | 83 | Recorded |
| 241C | Mar. 10 | 10:45 a.m. | 3301W | 85 | Recorded |
| 299S | " 10 | 5:10 p.m. | No. 4 S | - | No trace |
| 300S | " 12 | 1:45 p.m. | 4201W | .5 | No trace |
| 242C | " 27 | E | 3701W | ? | F |

DOMINION OBSERVATORY

| No. | Date | Time | Location | Tons | Remarks |
|--------|---------|------------------------|--|------|----------|
| 301S | Apr. 6 | 12:55 a.m. | 3214E) 3307W) 3001W) 3002W) 3010W) | 8 | No trace |
| 243C-H | " 9 | 11:50 p.m. | 3025W) 3201W) 3202W) 3214W) | 235 | Recorded |
| 244C-H | " 12 | 5:45 a.m. | 4002E | G | Recorded |
| 302S | " 16 | 7:10 p.m. | 3002W | 12 | Recorded |
| 245C-L | " 18 | 2:45 p.m. | 4202E | 50 | H |
| 246C-L | " 27 | 10:30 a.m. | 5001W | 60 | No trace |
| 247C-L | " 29 | 1:50 a.m. | 3401W | 20 | I |
| 303S | May 3 | J | 4202E | 5 | No trace |
| 304S | " 15 | 2:50 p.m. | 3307W | 50 | Recorded |
| 305S | " 16 | K | 4001W 3401W) 3406X) | 15 | No trace |
| 248C-M | " 20 | 2:55 a.m. | 3409W) 3414W) | 220 | Recorded |
| 249C-L | " 20 | 8:45 p.m. | 4001W | 150 | Recorded |
| 306S | " 23 | 8:00 p.m. | 4301W | 5 | Recorded |
| 307S | " 23 | 9:55 p.m. | 4202E | 20 | Recorded |
| 308S | June 5 | 1:45 a.m. | 3307W | 8 | No trace |
| 309S | " 5 | 10:25 a.m. | 4001W | 2 | No trace |
| 250C-L | " 12 | 9:20 a.m. | 4301W | 10 | No trace |
| 251C-M | " 13 | 2:45 a.m. | 3802E) 3902E) | 170 | Recorded |
| 310S | " 15 | L | 4001W 3301W) | 20 | M |
| 252C-M | " 20 | 1:25 a.m. | 3401W) 3501W) | 40 | Recorded |
| 311S | " 28 | 2:41 a.m. | 4201W 4001W) | 5 | Recorded |
| 253C-M | June 29 | 2:40 a.m. | 4201W) | 75 | Recorded |
| 312S | July 10 | N | 4001W | 50 | O |
| 313S | " 17 | 2:30 a.m. | No. 6S | 23 | No trace |
| 314S | " 21 | 3:00 p.m. | 4202E | 10 | P |
| 315S | " 22 | 9:00 p.m. | Q | .5 | No trace |
| 254C-L | " 23 | 3:00 p.m. | 4502E | R | No trace |
| 316S | " 24 | 2:40 p.m. 8:30 a.m. | No. 6S | 10 | Recorded |
| 317S | " 25 | 3:00 p.m. | 4202E | R | Recorded |
| 318S | " 29 | 3:48 a.m. | ? | 10 | No trace |

ROCKBURST RESEARCH 1938-45

69

| No. | Date | Time | Location | Tons | Remarks |
|--------|---------|------------|----------|------|----------|
| | | | 3901W) | | |
| | | | 3908W) | | |
| 255C-H | " 30 | 9:39 p.m. | 4001W) | T | Recorded |
| | | 9:46 p.m. | 4201W) | | Recorded |
| | | | 4301W) | | |
| 319S | Aug. 1 | 8:15 p.m. | U | 20 | No trace |
| 256C-L | " 12 | 3:05 p.m. | 3802E) | 20 | Recorded |
| | | | 3902E) | | |
| 257C-L | " 16 | D | 4301W | 40 | Recorded |
| 320S | " 26 | 2:45 p.m. | No. 6 S | - | No trace |
| | | | 4402E) | | |
| 258C-L | " 29 | 6:15 p.m. | 4502E) | 60 | Recorded |
| 321S | Sep. 3 | D | 3307W | 10 | Recorded |
| 322S | " 10 | 2:35 a.m. | No. 6 S | 10 | Recorded |
| 259C-L | " 11 | 1:20 p.m. | V | 72 | Recorded |
| 323S | " 18 | 3:20 a.m. | 3906E | R | Recorded |
| | | | 4302E) | sev- | |
| | | | 4401E) | eral | |
| 260C-H | " 20 | 2:30 a.m. | 4402E) | tons | Recorded |
| | | | 4501E) | each | |
| | | | 4502E) | loc. | |
| | | | 4402E) | | |
| 261C-M | " 21 | 1:45 p.m. | 4502E) | 100 | Recorded |
| | | | 2401W) | | |
| | | | 2501W) | | |
| 262C-L | " 23 | 9:40 p.m. | 2504W) | 60 | Recorded |
| | | | 2575X) | | |
| | | | 4201W) | | |
| 263C-L | " 27 | 3:00 p.m. | 4301W) | ? | Recorded |
| 324S | Oct. 8 | 9:25 a.m. | 3325X | 8 | Recorded |
| 325S | " 9 | 3:05 a.m. | 5401W | .5 | No trace |
| | | | 4002E) | | |
| 264C-L | " 11 | 3:10 a.m. | 4202E) | 170 | Recorded |
| 326S | " 21 | 10:30 p.m. | 4301W | 15 | W |
| 265C-M | " 24 | 3:01 a.m. | 4202E | X | Recorded |
| 266C-L | " 24 | 4:27 a.m. | 4200X | 40 | Recorded |
| 327S | " 24 | 7:00 a.m. | 3307W | 20 | Y |
| 328S | " 25 | 7:15 p.m. | No. 6S | 2 | No trace |
| 328S+ | " 28 | 10:26 p.m. | 3202W | 2 | Recorded |
| 328Sx | " 28 | 11:15 p.m. | 3202W | 35 | Recorded |
| 329S | Nov. 14 | D | 4001W | 20 | Recorded |
| 330S | " 17 | 10:30 a.m. | 4502E | 1 | Z |
| | | | 4409X) | | |
| 267C-M | " 19 | 10:30 a.m. | 4501E) | 50+ | Recorded |
| | | | 4501E) | | |
| 268C-M | Dec. 7 | 8:40 a.m. | 4502E | 125 | Recorded |

- A If dates are correct, the serial numbers 294S and 295S are inverted. At 1:30 a.m. on the 19th, which might possibly be intended for 295S, there was no trace.
- B The seismograph not recording at this time, owing to lamp failure.
- C Time reported simply as 'between shifts'. The report was not included in the regular S series and has been assigned the number 296S+ by the writer.
- D Time reported as 'between shifts, p.m.'.
- E Reported simply as 'between shifts'.
- F Adjustment of apparatus interfered with the record during the p.m. off-shift period. There was no trace on the a.m. off-shift period.
- G 'Several hundred tons'.
- H Recorded very feebly.
- I It is not certain that this was recorded. There was no trace at the time and date given; but, if either were in error, it might have been the record at 2:28 a.m. on the 29th, or at 1:46 on the 30th.
- J Time given as 'between day and night shifts'.
- K Time given as 'between 3 a.m. and 7 a.m.'.
- L Time given as 'between Saturday night and Monday day shift'.
- M Either No. 116 and 117 of the serially numbered bursts recorded on the surface seismograph might be 310S.
- N Time given as '3 to 7 p.m.'.
- O Two bursts at 3:00 and 3:01 p.m., which are probably to be identified jointly as 312S.
- P Small offset at 2:24 p.m. on 21st may be 314S, but the record is very feeble and the time does not agree well with the reported '3 p.m.'.
- Q Level 5200 in pilot raise of No. 6 shaft.
- R 'Several tons'.
- S 'Five bursts of which three were heavy'.
- T The damage due to these bursts (there were three) was great. The several displacements were reported as '210 tons', 'several hundred tons', '30 tons', and 'a small amount'.
- U 'No. 4 shaft at 5325-ft. level'.
- V Pillar between 2722 and 2725 cross-cuts. Note the very small half amplitude on the surface seismograph (5 half mm.) for a displacement of 72 tons.
- W Discrepancy of 20 min. in time. The recorded amplitude is large, but there is no other offset that may be identified as 326S, for which the displacement was 15 tons.
- X 'Several tons' and '30 tons'.
- Y Not recorded, but may have occurred while sheets were being changed at 7:06:30 to 7:07:30 a.m.
- Z Burst 330S is reported as having occurred at 10:30 a.m. on the 17th. There is no trace of an offset at that time. It is possible that No. 290 (Surface Seis.) at 10:35 a.m. on the 16th might be so identified.

Report H

Velocity of Elastic Waves and Structure of the Crust
in the Vicinity of Ottawa, Canada

The data upon which this study is based were obtained from ten rockbursts that occurred during a period of about 3 years in the Lake Shore mine, Kirkland Lake, Ont. and were registered on the short-period, vertical Benioff seismograph at Ottawa. Such bursts are strictly comparable to earthquakes as regards the mechanics of energy release. At least two of them were so severe that they were recorded at Weston, Mass. at an arcual distance of 581 miles.

The ten bursts originated at depths ranging from about 2000 ft. to 4000 ft. and, in plan, lie within a rectangle 1600 ft. by 500 ft. As the arcual distance from Ottawa to Lake Shore Mines is 450 km. (279 mi.), the foci were essentially at the same distance from the recording station, the variation being less than one part in 7000. Regarding the bursts as earthquakes, they may be said to have originated at zero depth.

The records were all made on the same seismograph, set at the same constants, and having a paper speed (synchronous motor drive) of 60 mm./min. The time service throughout was that of the Dominion Observatory. The correction to be applied is much less than the error of reading even the most sharply marked phase on the seismograms. For such well-marked phases, the error of reading the arrival times at Ottawa is about $\pm .25$ sec.

Only two of the bursts were accurately timed at Kirkland Lake, eight of them having occurred before the installation of the seismograph there. The paper speed of this instrument was 30 mm./min. The time marks were put on the seismogram by a Dent chronometer, mounted in a supplementary wooden box supported by a bracket on a brick wall of an inside basement room. The chronometer had been reinstalled, after cleaning and adjusting, twelve days before the bursts (within about 7 min. of each other on July 30, 1941), and had been rated by automatically recorded time signals, in general oftener than once a day, and always at least once. For the entire 12 days the rate was zero, the correction at each check being + 15.0 sec. The time of occurrence could be read from the sharply defined record to within $\pm .5$ sec.

In the above circumstances, and with two records available for averaging, it is safe to say that the travel time for the well-marked phases is known to within about half a second.

H-1 Tabulation of Data

| Record | Date | Time | Depth | Intensity | Coordinates (x-y-z) |
|--------|------------|----------|--------|-----------|------------------------|
| A | XII-27-38 | 23:49:50 | 2700 | 6 | 9-5-13 |
| B | III-11-39 | 20:49:07 | 3500 | 2 | 12-2- 5 |
| C | III-28-39 | 13:09:28 | 3000 | 1 | 16-0-10 |
| D | VIII-31-39 | 2:51:55 | 3600 | 9 | 9-2- 4 |
| E | VIII-31-39 | 3:01:55 | 3600 | 8 | 9-2- 4 |
| F | IX- 2-39 | 13:44:50 | 3800 | 5 | 8-2- 2 |
| G | IX-19-39 | 22:54:44 | (2000) | 10 | 8-5-20 |
| H | IX-19-39 | 23:06:59 | (2000) | 7 | 8-5-20 |
| I | VII-30-41 | 21:39:02 | 4000 | 3 | 0-0- 0 |
| J | VII-30-41 | 21:46:17 | 4000 | 4 | 0-0- 0 |

Record designations are assigned in chronological order.

Times are given in E.S.T. on the 24-hr. system beginning at midnight. The occurrence times for bursts A to H inclusive were computed from the Ottawa records, using the same elapsed times as obtained for the bursts I and J, which were the only ones directly timed by the Kirkland Lake seismograph. The second of the three bursts shown in Figure 41., occurring between I and J, was not of sufficient intensity to register at Ottawa.

Brackets on depth numbers indicate approximate values. Bursts G and H together extended, in depth, from 800 ft. to 3000 ft. in a shaft pillar, the greatest damage being from 1400 ft. to 2600 ft.

Intensity numbers (1-10) simply relative intensities, increasing with the number order.

The coordinates x-y-z are expressed in hundreds of feet, x being measured positively E 30°N, y being measured positively N 30° W, and z being measured positively upward from 4,000 feet.

Zero of coordinates is taken at the position of the bursts of July 30, 1941.

Greatest ranges are: x = 1600 ft.

y = 500 ft.

z = 2000 ft. (\pm 600 ft.)

Geographical coordinates of No. 5 Shaft, Lake Shore Mines:

80° 02' 43" W.

48° 08' 57" N.

Geographical coordinates of the Ottawa station are:

75° 42' 57" W.

45° 23' 38" N.

Computed azimuth, Kirkland Lake to Ottawa, S 49° E.

Computed azimuth, Ottawa to Kirkland Lake, N 45° W.

Computed arcual distance Ottawa to Kirkland Lake, 279 mi. (450 km., 4°).

H-2 Layout of Seismograms in Figure 42

When the ten records are copied so as to be as exactly as possible on the same scale, and are mounted so as to place a certain well-marked phase on each in the same vertical line, it is found that at least five phases are clearly defined on each, several others appearing on some of the records only.

If the crust in the region concerned be considered to have two discontinuities defining three layers and if the layers, in order from the surface down, be designated as 1, 2, and 3, then P_1 , P_2 , and P_3 indicate respectively the longitudinal waves arriving at Ottawa through the three layers in order; and similarly, S_1 , S_2 , and S_3 indicate respectively the transverse waves arriving at Ottawa through the same three layers.

The five phases definitely recorded on all the records are identified, in order of arrival at Ottawa, as P_3 , P_2 , S_3 , S_2 , and S_1 . On every seismogram P_2 is very sharply defined. There is an indication of P_1 on records A, B, D, E, and G, but it is not sharply recorded on any of these. The other phases are well defined on some and not as well on others. However, knowing that the shocks had a common origin, that the intensity (with its governing factors) is practically the only cause of variation in trace, and that the travel times for all must be the same, it is permissible to combine the ten records to obtain:

- (a) the time sequence of arrival of the phases.
- (b) the focal time for each of the ten bursts.

These data are set forth in the next section.

H-3 Readings for the Ten Seismograms

Arrival Times for an Arcual Distance of 450 km. (279 mi.)

| Rec. | H | P ₃ | P ₂ | P ₁ | S ₃ | S ₂ | S ₁ |
|------|------------|----------------|----------------|----------------|----------------|----------------|----------------|
| - | 0 | 1:01.5 | 1:11.5 | (1:22.5) | 1:48 | 2:01 | 2:13.5 |
| A | 23:49:49.5 | 50:51.5 | 51:01 | (51:12.5) | 51:38 | 51:51 | 52:03 |
| B | 20:14:06.5 | 15:08.5 | 15:18 | (15:30) | 15:55 | 16:08 | 16:21 |
| C | 13:09:28 | - | 10:40 | (10:51) | 11:16 | 11:30 | (11:43) |
| D | 2:51:55 | 52:56 | 53:06 | (53:18) | 53:43 | 53:56 | (54:08) |
| E | 3:01:55 | 2:57 | 3:07 | (3:18) | 3:43 | 3:56 | 4:08 |
| F | 13:44:50 | 45:52 | 46:02 | (46:13) | 46:38 | 46:51 | 47:03 |
| G | 22:54:44 | 55:45.5 | 55:55.5 | (56:06.5) | 56:32.5 | 56:45 | 56:57 |
| H | 23:06:58.5 | (8:00) | 8:10 | (8:22) | 8:46 | 9:00 | 9:12 |
| I | 21:39:01.5 | - | (40:13) | (40:25) | (40:50) | (41:03) | 41:15 |
| J | 21:46:17 | 47:19 | 47:28.5 | (47:40) | 48:05 | 48:18 | 48:30 |

The entries in the first line are minutes and seconds of elapsed time, obtained by taking zero focal time and the best estimate of phase time obtained from the records. All the other entries are the hours, minutes, and seconds (in the first column) or minutes and seconds (in the remaining columns) of recorded time for each rockburst.

Brackets indicate that an increase of energy seems to be recorded at the expected phase time, but that the phase cannot be accurately timed.

The P₁ values for records A and G are the two readings used to get that range value in the first line.

L-waves appear definitely on record H only.

H-4 Explanation of Figures 41 and 42

Figure 41 presents the Kirkland Lake surface seismograph records of three bursts that occurred at Lake Shore on July 30, 1941. These are designated I, Ia, and J. The second burst did not register on the Ottawa seismograph: the others produced respectively the seismograms designated I and J in section H-1. The times of occurrence (H) are:

$$H_I = 21:39:01.5$$

$$H_{Ia} = 21:39:09.5$$

$$H_J = 21:46:17$$

Figure 42 presents the ten seismograms listed in section H-1. They were compiled into the composite lay-out, care being taken to have the scale exactly the same throughout. They were then laid out in order chronologically from top to bottom, with the well-marked phase on each (P_2) in line. The following points should be noted:

- (a) The principal phases are marked, e.g. a straightedge from P_3 at the top to P_3 at the bottom will pick out that phase on each of the seismograms.
- (b) Interval P_3 to P_2 was obtained from the records A and G.
- (c) Interval P_2 to P_1 was obtained from the records A and G.
- (d) Interval P_2 to S_3 was obtained from the records A, H, and G.
- (e) Interval S_3 to S_2 was obtained from the records A, B, H, and J.
- (f) Interval S_2 to S_1 was obtained from the records A and F.
- (g) Interval H (focal time) to P_2 was obtained from record J.
- (h) Extra phases may be noted as follows:
 - (1) about 1.5 sec. after every phase on record D.
 - (2) about 1.5 sec. after P_3 on the records A and G.
 - (3) about 3 sec. after S_3 on records A and H.
 - (4) about 3 sec. after S_2 on records A, F, and J.
 - (5) about 2 sec. after S_1 on records A and J.
 - (6) about 3 sec. after S_1 on records A, B and J.

H-5 Earth Structure Deductions

In 1934, Saint Louis University published a set of "Tentative Tables of Travel Times for Near Earthquakes", prepared under the direction of Father Joseph S. Joliat, S.J., and based on velocity values determined by Jeffreys for northern Europe, namely:

| | V_p | V_s |
|---|--------------|---------------|
| 1 | 5.4 km./sec. | 3.3 km./sec. |
| 2 | 6.3 km./sec. | 3.7 km./sec. |
| 3 | 7.8 km./sec. | 4.35 km./sec. |

Joliat assumed that the focus lay at the bottom of the uppermost layer, not at the surface as is the case with rockbursts. A comparison of the travel times obtained for the rockburst records at Ottawa (H) with the Joliat values (J) for the same distance (450 km.) follows:

Travel Times for an Arcual Distance of 450 km.

| | P_3 | P_2 | P_1 | S_3 | S_2 | S_1 |
|-----|-------|-------|--------|-------|-------|-------|
| J | 62.5 | 72. | 83. | 111 | 122 | 134 |
| H | 61.5 | 71.5 | (82.5) | 108 | 121 | 133.5 |
| J-B | 58. | - | - | 104 | - | - |

The travel times shown in the latest tables by Jeffreys and Bullen (J-B) are also given for P_3 and S_3 the only values tabulated by them for such a short distance. They assume a depth of focus of 14.5 km. in a layer 15 km. thick.

Differences of the magnitude found in the above were to be expected because of the difference in focal depth, but they may also be due, in part, to the differences in structure (and associated velocities) in the vicinity of Ottawa as compared with those of northern Europe, where the instrumental data that were the basis for the Jeffreys-Bullen tables were collected; these tables were used, in turn, by Joliat, in connection with an arbitrarily selected, hypothetical, crustal structure, in computing his tables for near earthquakes.

The sequence of arrival times in the H line above gives one set of points defining travel-time curves for rockburst records in the vicinity of Ottawa. Up to an arcual distance of 10° (1110 km., 690 mi.) such curves may be considered to be straight lines. One more set of points would define these lines and permit the computation of rockburst travel time tables; these, with some small modifications, could be adapted to apply to local earthquake tables. From the same data, the thickness of each of the layers and the six velocities concerned could be deduced.

Burst G was well recorded at Weston, Mass., and at Shawinigan Falls, Que., thus furnishing two such sets of points. The focal time for the burst can be obtained with considerable precision, on the basis of the ten burst seismograms recorded at Ottawa. There is, however, only one record defining two other points on each of the travel time graphs at each of the other stations. A least squares solution is necessary to permit the deduction of the most probable values to fit the observational data of varying weights. A set of tables based on the deduced structure and velocities, and assuming a focus at the surface, can then be computed. These tables can be used in the vicinity of Ottawa for both rockbursts and earthquakes. The corrections necessary to convert the tables for use where the focus is not at the surface must also be computed and supplied.

It is evident from the preliminary work on the material that the P-velocities are higher than those obtained by Jeffreys for northern Europe and used by Joliat in his tables. The values, subject to corrections, obtained by the preliminary investigation are:

$$P_1 = 5.5 \text{ km./sec.}$$

$$P_2 = 6.5 \text{ km./sec.}$$

$$P_3 = 8.1 \text{ km./sec.}$$

as compared with those of Jeffreys given in section H-5 above. The S-velocities appear also to be slightly higher than the corresponding Jeffreys figures there tabulated.

In terminating this analysis of the ten rockburst records, it is to be noted that other phases appear on some of the seismograms. These are, perhaps, more easily noted on record A. Some of these are more pronounced on the Shawinigan Falls record of burst G. This is to be expected since the Ottawa record was made on a vertical Benioff seismograph and the Shawinigan Falls record on a horizontal Wood-Anderson instrument. The Weston records are Benioffs, both horizontal and vertical. When they are received, these extra phases will be studied in an attempt to deduce other peculiarities of structure in the area.

H-6 Evidence of Rockburst Mechanism

A further point of interest should be noted. The fact that these records were due to a burst might lead to the supposition, a priori, that the first impulse would be anaseismic, away from the origin. In every case however, this first impulse was kataseismic, i.e. toward the origin. The rock yielded, bursting out into the stope and development drifts, and the impulse was transmitted as a rarefaction. As at date of writing, the rockburst records obtained at Ottawa are all definitely kataseismic.

H-7 Summary

The centre of each of the ten bursts was located within a few feet, but for the purpose of preparing travel time tables, they may all be considered to have occurred at a single point at the surface. Two of the bursts were accurately timed on the surface seismograph at the mine.

Six phases were registered on each seismogram, being more sharply marked on some records than on others. Five of these are well defined on nearly all the records. It was thus possible to deduce a set of arrival times at a distance of 450 km. for a burst (or earthquake) occurring at the surface, and this set of times was known with considerable precision, since all the readings could be combined. The distance was determined within one part in 7000, the depth within 2000 ft., and the travel times with an error of $\pm .5$ sec.

These travel times were compared with those obtained by Joliat in computing his Tables for Near Earthquakes, based on the velocities deduced by Jeffreys for northern Europe and arbitrarily assuming an earth structure with two layers above the Mohorovicic discontinuity. The differences were minor and may be explained as largely due to the fact that Joliat assumed the focus to lie at the bottom instead of the top of the upper layer.

On the strength of the comparisons afforded by the ten seismograms, the focal time of each burst may be considered as known to within a half second. One burst was so severe that it registered at Shawinigan Falls Que. (576 km., 358 mi.) and Weston, Mass. (935 km., 581.) also. These records afforded a means of deducing the earth structure and velocities in the vicinity of Ottawa, and made possible the construction of tables for rockbursts and earthquakes in that area up to 10° (1110 km., 690 mi.)

Further work on this problem was interrupted because of the pressure of research duties at the mine. It was later resumed by John H. Hodgson, who obtained points on the time-distance curves by setting up temporary stations at ever-increasing distances from Kirkland Lake and utilizing the records from rockbursts timed by the Kirkland Lake seismograph and located in the mine by the staff of Lake Shore Mines. A brief introduction to this work will be found at the end of this publication and a list of papers on the subject will be found in the Bibliography in the Appendix.

A paper by the writer, based on the material of Report H, appeared in the Bulletin of the Seismological Society of America, Vol. 32, No. 4, 249-255, 1942.

Report J

Initial Obert Experiments
April 15, 1941 to June 30, 1942

During the period under review, the experiments with the microgauge were continued. On July 30 the gauge was slightly injured by the triple bursts in 4200W, the first and last of which are the only two so far recorded at Ottawa since December 1938.

Improvements to the mine and surface seismographs greatly improved their recording. The strain gauge caught in a burst on 3001W on July 8, 1941 was recovered, repaired, and again placed in service.

Experiments leading to the development of ultrasonic equipment had progressed to a point where the instruments were about ready for service when contact was made with Dr. Leonard A. Obert, of the United States Bureau of Mines. His experience indicated that the ultrasonic vibrations could not be picked up more than a few feet from their source. He was obtaining good results with instruments sensitive to vibrations of 1000 c.p.s., but subaudible.

Dr. Obert was most cooperative; he accepted an invitation to demonstrate his equipment, both at Frood and at Lake Shore. As a result, towards the end of June 1942 three sets of Obert instruments were in operation at Lake Shore. On June 30, the writer assumed direct conduct of the underground program.

After Obert's visit in late October, a listening program was begun at a selected number of drill holes in the west pillar. This was continued without interruption to the end of the project on November 30, 1945. Report J deals with these developments in the order in which they occurred.

J-1 Mine Seismograph Program

This instrument was reconditioned and was moved on August 11 to a point about 120 ft. west of the junction of 3053W drift, which connects with 3052 cross-cut at a point about 1500 ft. north of the north vein (Figure 27). Electricity was carried to this point, so the seismograph no longer depended on battery operation. The seismometer employed was Heiland geophone No. 357, and the recorder a commercial 5-milliampere Esterline-Angus meter. The amplifier, built by Gibbs, was equipped with a wave filter. Twice each day for a period of about 5 minutes a telechron clock repeatedly placed and lifted a test weight on and off the mass of the geophone, by means of the device illustrated in Figure 43. The records were changed once a week and analysed.

J-2 Control Panel for the Surface Seismograph

As considerable lost time was experienced with the surface seismograph because of lamp failure, a warning device was designed and put in operation by Gibbs. The 115-volt supply provided a power source for the synchronous motor and the light; a transformer between the lamp and the supply cut the voltage. Into this circuit Gibbs introduced a resistance. Bridging this resistance and using the voltage drop across it, a copper oxide rectifier provided current to operate a relay. As long as the light was in service the relay remained open. If it failed, the relay closed a circuit that actuated buzzers in the laboratory and in Gibbs' house.

This device, together with the circuit to drop a test weight on the geophone, made it desirable to have a control panel set up. This proved most useful in reducing lost time in the recording of the surface seismograph, and made it very convenient to adjust the light intensity, etc. A telegraph key in the adjoining radio room permitted the operator to close the relay that placed the test weight on the geophone. This was done each day before removing the completed seismogram and also just after putting a fresh sheet on the drum.

J-3 Severe Rockbursts of July 30, 1941

On July 30, at about 9:40 p.m., three severe rockbursts occurred from the 3900-ft. level to the 4300-ft. level, causing considerable damage. The first and last of the shocks were of sufficient intensity to record at Ottawa — the first such recording since the rockburst of December 28, 1938, also the first of the recording rockbursts to be timed at Kirkland Lake. Report H deals with the data from these bursts.

J-4 Experiments with the Microgauge

While the experiments with the microgauge, described in Report F, were being carried out during May and June 1941, Gibbs and Hallick experimented at the mine with a specimen gauge left at the mine by Hollinsworth, in an attempt to stabilize the zero and to obtain data underground.

On July 28, the gauge was installed in a bore hole at the back of the safety station at the extreme south end of the main cross-cut on the 4200-ft. level. It showed some variation during the first three days, which seemed to indicate that pressure was lessening in the azimuth of the bore hole crossed by the gauge contacts.

The heavy triple burst of July 30 occurred while the gauge itself was temporarily replaced by the reference standard. This device had just been installed when the burst occurred. The next morning the gauge was again placed in operation in the same drill hole. The drift of the previous three days had disappeared. It is possible that the gauge movement

prior to the burst may have been due to temperature effects that later became equalized. The equipment was in good working order, but the only azimuth that could be checked with the single gauge did not present a complete picture of conditions.

J-5 Meeting with Obert

In September 1941, the writer met Dr. Leonard A. Obert of the United States Bureau of Mines in Washington. Dr. Obert had been studying rockbursts for some years, and had developed an instrument that recorded subaudible (but not supersonic) snaps. These are said to indicate, by an increase in the number per minute, the imminence of a rockburst. Dr. Obert was invited to try his equipment in the Frood mine at Sudbury and at Lake Shore Mines. The visit was made to Sudbury on October 17-21 and to Kirkland Lake, October 22-26. The report of the meeting of Hodgson and Obert in Washington is given in section J-6 below and of the visits to Frood and Lake Shore in section J-7.

J-6 Notes on Obert Equipment

(a) Recording Paper

The Obert seismic equipment uses a paper specially developed by the Western Union Telegraph Company for use in its facsimile transmission work. The paper is three-layered, that next the drum being aluminum-coloured (this is probably a special conducting material), the middle layer black, and the face of a thin, hard, smooth-surfaced paper. Recording is accomplished by a stylus carrying a current of about 7 milliamperes to 180 to 200 volts.

The stylus can record clean-cut lines at frequencies as great as 10 c.p.s.. At a paper speed of 2 inches a minute, close tracings are not confused, as would occur as a result of halation in photographic recording, and blotting if ink were used. Other advantages are: low friction on stylus; low price; no development delays; no lighting problems; ability to see the results of tests and adjustments as made.

The only disadvantage is that if the stylus remains too long on one spot (as in the case of the paper feed failing) the paper may become ignited. However, the paper smoulders, rather than burns, and so no fire hazard is involved, although damage to the drum and stylus may result. The paper is marketed under the name 'Teledeltos'.

(b) Pick-up Device

The pick-up device utilizes the piezo-electric effect. Two crystals of Rochelle salt are separated by a conducting leaf at one potential with connected conducting leaves at the other potential on the outer faces. The built-up crystal is 2.5" long, 0.75" wide, and 0.25" thick; the natural frequency of the crystals is 800-900 c.p.s.

The crystal is 'spring-board' mounted in a heavy metal cylinder with rounded ends, one of which has a water-tight gasket for the electric cable. The whole pick-up is 7" long and a little more than one inch in diameter. It is simply laid in a drill-hole that has been blown clean and dry by compressed air.

Total cost of the pick-up, which is made in the Bureau of Mines (U.S.) workshops, is \$6-8, exclusive of labour, as against \$150-200 for the commercial seismic pick-ups hitherto used.

(c) Recording System

The recording system uses an amplifier, filter's, and recorder made at the Bureau. The recording device consists of a writer coil, designed to obtain high impedance, operating a steel stylus. The output current from the amplifier is rectified. The amplifier has practically flat gain for the range 50-10,000 c.p.s., but the system is peaked slightly by the natural frequency of the crystal pick-up.

Two recording devices are used to register the impulses from one geophone. One operates through an integrating device with an integrating time of one-tenth of a second (referred to as the 'A' recorder), and the other through a device with a time of one second ('B' recorder).

The devices record side by side on Teledeltos paper, the A recorder indicating the amplitude of the maximum throw or voltage variation of a wave train, and the B the integrated energy. By careful comparison of the dual record it is therefore possible to determine whether an impulse was from a nearby small pulse with a wide amplitude but small train, or originated as a more severe shock at a greater distance. By comparing the dual record from various points in the mine, as well as the reports made by miners, it is possible to determine approximately where all the larger pulses originate.

(d) U.S. Field Work with Obert Equipment

Most of the recent work with the Obert equipment was done in the Ahmeek Mine, Ahmeek, Mich. At this mine, blasting is almost entirely restricted to 15 minutes twice daily, at which times the recording devices are shut off. Speed of operation is relied on to keep ahead of bursting conditions, and no large bursts are experienced; small bursts occur in cycles.

In the work here, it was noted that when the detected snaps in the vicinity of any given pick-up become numerous (sometimes 200-300 per ten-minute interval) a burst occurs in that part of the mine within 24 hours. The snaps are always more active for a short time after blasting: they are quite inaudible, and can be detected by the seismic equipment only.

The above is directly opposite to what had been expected. It had been thought that the frequent releases of pressure shown by the recorded snaps would preclude a build-up of pressure, and that a burst would be expected only after a period of quiescence. Obert suggested that the frequent noises indicate a general increase of pressure with slight release along some of the fault faces, leading up to a build-up of pressure to bursting value in one or more of the blocks. The suggestion seems reasonable in view of the different occasions when a burst has followed a period of marked unrest, and is supported to some extent by the initial plotting at Lake Shore of integrated burst activity.

(e) Characteristics of Recording

The Obert equipment is much more sensitive than that used at Lake Shore: the blow of a one-pound hammer on the wall of a drift 1,000 ft. distant gives offsets of about one-eighth of an inch on the record. This method is, in fact, used a rough test of sensitivity. The chief disturbance comes from rock drilling--something scarcely affecting the Lake Shore equipment. The reason is that drill disturbance is of high frequency, about 1,000 c.p.s., while the Lake Shore equipment is sensitive to frequencies of about 100 c.p.s. Filters can greatly reduce drilling noise, but cannot eliminate it.

(f) Observations on Frequency

Obert considers that impact on an elastic body causes the generation of a wide spectrum of frequencies. If these are plotted for various types of disturbance, the peak of the spectrum curve occurs at characteristic positions along the frequency abscissa. He considers also that blast and burst spectra have peaks at different frequencies, but that each generates some amplitude at all frequencies: moreover, the waves damp out in the rock at distances that vary with the frequencies. He believes that the snaps with which he has been working carry for 20 ft. or less, and that his studies are therefore limited to areas within 20 ft. of the equipment.

Evidently, the amplitude of the record made by any type of equipment depends on such factors as:

- (i) The energy released in the various frequencies, i.e. the initial spectrum curve.
- (ii) The filter system, which cuts down the intensities of record for certain frequencies.
- (iii) The gain factor of the amplifiers for various frequencies.
- (iv) The resonance characteristics of the pick-up, and the recording mechanism for various frequencies.
- (v) The distance from source to recorder, which causes higher frequencies to damp out more than the lower one, i.e. the spectrum at the recorder.
- (vi) The path between the source and the recorder, which tends to be better in some parts of a mine than in others.

Obert considers that it is quite possible to build equipment that would record the snaps that he believes occur under increasing pressure at frequencies as high as 15,000 c.p.s. He believes, however, that such snaps could not carry for more than 2 or 3 inches (or as many feet at most), and that data from so small a volume of rock would be of little value. If we decided to carry on work along the lines he had developed, he recommended the use of Y-cut quartz crystals, as they are not affected by moisture.

(g) Direct Approach to the Problem

To design the optimum equipment for detecting and recording mine noises and sub-audible snaps that might serve to give warning of approaching bursts, the factors listed in the preceding section would have to be studied in detail, particularly those concerned with frequencies. The studies would involve the securing of records at various frequencies with optimum response characteristics in order to determine for which choice of frequency the most definite warning of an impending burst is conveyed. Obert considered that this frequency would be about the 1,000 c.p.s. level.

(h) Alternative Methods

In the course of studying the elastic constants of rocks under pressure, Obert found, as had Birch and others, that the velocity curve flattens markedly after pressures definitely below bursting values have been reached. It cannot therefore be used to predict bursts, but is of value in determining pressures in residual pillars from which it is desired to extract the ore.

Obert has constructed a high-speed camera that makes it possible to measure directly velocities over paths of 1,000 ft. or less with a timing accuracy approaching $\frac{1}{1,000}$ of a second. In carrying out direct measures of seismic velocity, he found that a short length of wire laid in the drift at the recording point would pick up the electric surge caused by blasting 1,000 ft. and more away. He suggested that this is the cause of the high-frequency disturbances preceding the blast frequencies as shown in Figures 29c, d & e, the surge of the blasting current being carried by the rock and picked up by the seismometers. Later experiments at Lake Shore tended to confirm this theory.

J-7 Experiments at Frood and at Lake Shore

(a) Frood:

It was decided to visit Frood mine on the night of Oct. 19, as this was one of the alternate Sundays when the mine was not operating. The company arranged to have a number of holes drilled on the 2800-ft. level, near the top of No. 6 shaft, where the ground had been working for sometime. Cracks developing in the hoist room are being measured and studied regularly.

Frood mine has two large mineralized areas with a narrow, horizontal section connecting them. The initial development was done at the 2800-ft. level and mining continued upward. At the same time, open-pit mining was started on the surface and development drifts were opened below the 2800-ft. level.

Obert, Elves, Hollinsworth and the writer listened in at the prepared holes until about midnight. There were snaps from time to time, perhaps an average of four or five a minute. A few of these could be heard without the equipment, but most of them were quite inaudible without it: Obert said that the low pitch indicated that they were coming from a distance of about 1,000 ft. This would indicate the possibility of working ground at a distant point where the more frequent, higher-pitched noises, indicative of bursting conditions, might be heard; such noises do not carry more than about 50 ft. It was therefore decided to try a listening post on the 3100-ft. level. The holes were to be prepared on the following day so that listening could be done that night during the off-shift period.

No air or water being immediately available at the location selected, it was necessary to have lines laid. This work was just finished, and the drillers had not started, when a rockburst heaved the track for a distance of 60 ft. along the drift, broke timber, and threw out several tons of loose rock. The ground continued to 'talk', so the drillers did not put any holes in the burst section, but began drilling 10 ft. or so to the south, and continued at intervals for several hundred feet; similar holes were drilled north of the burst section. All were blown clean, ready for the experiments. The party consisted of Elves, Obert, A.E. Prince (Assistant Electrical Superintendent), and the writer. The first stop was made at one of the holes on the 2800-ft. level. The snaps were about the same as those heard the night before. They were about as frequent as they had been and were of the same low pitch, indicating a relatively distant origin.

The outfit was then moved to the 3100-ft. level and the first set-up was made at the hole nearest the south end of the burst section. The snapping was practically continuous. It sounded something like static, but many snaps had the hissing, spitting sort of sound heard when a neon sign has a poor connection. Heavier ones could occasionally be heard without the equipment.

The pick-up was left in this hole and another was placed in a hole some 75 ft. to the south. Two amplifiers and two sets of head phones permitted the observers to listen to both places at the same time. It was at once apparent that the high-pitched snaps were much more frequent in the hole nearer the burst section and that there was a marked lack of simultaneity in this sort of sound in the two locations. The heavier snaps were simultaneous. Occasionally a crack could be heard progressing through the rock as a crack crosses an ice-covered lake with a ripping sound on a very cold night.

Listening in at successively farther points going south, it was found that the high-pitched noises fell off until, at about 300 ft., there was not much more snapping than had been heard on the 2800-ft. level. (The direct distance from the burst on the 3100-ft. level, to the listening post on the 2800-ft. level was about 500 ft.)

While reeling in the line from the farthest south hole and while about 100 ft. from the burst section, another burst occurred at 3:45 a.m. This heaved the track still more in the section previously affected and also heaved the track in the next parallel drift 44 ft. to the east. It broke timber in both drifts and threw out several tons of loose rock in each.

The party returned to the hole first used, and installed the geophone. The activity was found to be about the same as before, as nearly as one could judge. The line was then carried through the burst section to place the geophone in various holes north of the section, the amplifiers remaining at the south end. It was found that the rock became noisier with 'local' cracking to the north, and that easily audible snaps and bumps were more numerous. At about 5 a.m., it was decided to move out. No further observations were made at Frood.

(b) Lake Shore:

On October 23, Obert, the writer, and mine personnel examined sections in 3202W, 3811E, 3802E, and 4301W. There were some diamond drill holes in each vicinity that had not been partly closed by the slabbing of exposed faces, and it was arranged that these should be cleaned out and the experiments begun in the afternoon shortly after blasting.

Two holes were tried in 3811E at approximately 500 ft. east of the main cross-cut on the north vein. The nearest (farthest east) hole was about 20 ft. west of the stoping on this vein. A few 'local' noises were heard and also a few distant ones, but there was very little activity. None of the sounds could be heard except with the equipment.

The party then moved to 4301W, to a point about 700 ft. west of the main cross-cut on the north vein. This is almost immediately below the large burst of July 30 last that affected the 3900-, 4000- and 4200-ft. levels. The ground here was a good deal more noisy. Practically all of the snapping was local. None could be heard except with the equipment. Attempts to plot the snaps on a time scale show an average of about three per minute.

This occurrence pattern in the mine with which Obert is best acquainted (Ahmeek, Mich.) would not indicate bursting conditions. Until the high-pitched snaps were recording from 20-30 per minute, that ground is considered safe. However, as stressed by Obert, the significance of the occurrence pattern at Lake Shore could only be learned by continuing observations over a period sufficiently long to include a burst in the vicinity of the listening post.

Although the observations were being made in the Lake Shore off-shift period, drills could be heard working in Teck-Hughes mine at a distance of not less than a quarter mile. These were sufficiently disturbing to prevent an accurate counting, but Obert was of the opinion that most of the local unrest would have registered if the recorder had been equipped with the proper filters.

It was decided to listen in at the same position on 4301W on the afternoon of Oct. 24 before, during, and after blasting. The amplifiers were kept at No. 5 shaft on the 4300-ft. level and cables were run to the pick-up placed just below the stoping. About 1200 ft. of cable was run out, but the listening was done through 1500 ft. There was no impairment of the sensitivity. Matching transformers were used at each end of the cable.

It was learned that the mining in the stopes immediately above the 4300-ft. level had not progressed far enough for blasting at the end of the shift. However, there were other stopes higher in the mine and in the same general area to be blasted.

It was found, even before blasting, that the rock was noisier in this section than it had been the day before. All the snaps were local in character. After blasting was completed, they increased in number and a few were audible. One was fully of burst proportions, but it is not known whether it caused damage anywhere. Careful counting by different members of the party gave snapping noises of 10-15 per minute at a time about an hour after blasting. Whether this indicates dangerous conditions can only be learned by experience.

On Oct. 25, two diamond drill holes on the 4200-ft. level were used. The more westerly of these was in the south wall of the small triangular pillar at the intersection of the north and diagonal veins with the main cross-cut. The other was in 4201E, about 200 ft. east of the cross-cut on the north vein. Two or three days before, a small burst had heaved the track and knocked down several tons of rock on the main cross-cut on this level. The re-laying of the track had just been completed. Two pick-ups and two amplifiers were used, with two sets of head phones, so the activity in the two holes could be compared. It was found that the noise was nearly all local in character and much of it not simultaneous. Sometimes the west pick-up was the noisier, sometimes the east. Careful counting showed 8-22 snaps per minute about half an hour after blasting had been completed. This ended the experimenting at Lake Shore.

J-8 Specifications for Obert's Equipment

Obert's equipment for studying the subaudible snaps consists of three units, for which the following specifications are given:

Unit No. 1:

- (a) A three-stage amplifier operated from the power supply, having a voltage gain of over 100,000 (from the grid of the first tube to the plate of the last tube).

Linear to frequency to within 2 db. from 150 to 10,000 c.p.s. An attenuator (0 to 45 db. in steps of 2.5 db.) is inserted between the first and second stages.

(b) A filter system consisting of a 2500-cycle and a 7500-cycle high-pass section with switching arrangement so that either section can be cut in. The filters have an attenuation of 40 db. in the first half octave below cut-off and an insertion loss of less than 3 db.

(c) A calibration circuit operated by a switch on the amplifier panel, showing the over-all response (with the exception of the first two stages) of the recorder.

(d) This unit is enclosed in a gumwood, copper-lined, carrying case with cover. Two 1620 and one 6P5 tubes are included.

Unit No. 2:

(a) A non-linear peak-limiting amplifier for compressing the recording scale.

(b) A one-stage, low-gain amplifier for independent regulation of the fast and slow recorder.

(c) Two signal rectifiers and time-constant circuits, one having a time constant of approximately 0.1 sec., the other of approximately 1.0 sec.

(d) Two class B amplifiers with approximately 8 watts output.

(e) A 90-120-volt, 25-60-cycle power supply (140 v.a.) having a voltage regulation such that the sensitivity of the recorder does not change appreciably on a power line fluctuating by as much as 15 per cent. All of the equipment is operated from this power supply.

(f) This unit is contained in a gumwood case with cover. The following tubes are included: 1-6J7-G, 2-5v4-G, 2-6p5-G, 2-6ZY5-G, 1-VR75, and 1-VR150.

Unit No. 3:

(a) This unit contains two magnetic recorders using Teledeltos paper at a speed of approximately 3 in. per minute: they will operate over eight hours on a 125-ft. roll of recording paper. The recorders are driven by telechron synchronous motors and a time mark is made on the paper every other minute.

(b) Five hundred feet of shielded two-conductor microphone cable with connectors.

The necessary connectors for all units are furnished. Amphenol plugs are used throughout.

J-9 Purchase of Obert Recorders

At the time Obert left Lake Shore (October 26, 1941), it was agreed that steps would be taken to arrange for the purchase of three complete sets. These were delivered to Lake Shore on May 20, and were at once placed in service.

Figures 44 and 45 present, respectively, a side and an end view of the Obert recorder with the box removed. Figure 86 shows a complete set in service and Figures 82, 83, 84, and 85 give the wiring diagrams for the sets, with some changes made in the light of experience. For example, the improved sets had two of the 0.1 sec. time-constant circuits, the 1.0 sec. integrating circuit being abandoned in favour of having twice the coverage with a given recorder.

The pictures of the uncovered recorder show the two alnico magnets, each with a writer coil and stylus. The roll of paper can be seen below the magnets in Figure 44. In Figure 45 the paper is in place for recording under the stylus points. The time-marking device can be seen in Figure 45, just above and to the right of the handle on the upper feed roller. A stylus in permanent contact with the paper near the edge receives a writing voltage for about ten seconds each two minutes, tracing a short dash on the record.

J-10 Listening Experiments:

Using a geophone loaned by Obert and the amplifier (LSM-10) designed and built by Gibbs for the supersonic studies previously planned, a listening program was begun November 5, and continued each day (except Sundays and holidays) until June 20, 1942. At first the LSM-10 amplifier * was used and later the LSM-11; then, beginning May 21, the Obert recorders went into service. From time to time during the period May 21-June 20, it was necessary to use the LSM-11, owing to trouble with the Obert writer coils.

Beginning November 5, listening was done on the 3825-ft. level, the geophone being below 3811E drift in 3906E stope and the amplifiers in the charging station on the main cross-cut. Listening continued until May 1, when the equipment was moved to a 'doghouse' on the main cross-cut on the 4200-ft. level, remaining there till June 20. During the entire period November 5 — June 20, most of the listening was done during the afternoon blasting period (2:45 - 4:55 p.m.). Geophones were installed in several of six holes in 4201W-7; these holes were all in the south (hanging) wall, and were about 6 ft. deep and 30 ft. apart. Attempts were made to record for 10 minutes from each hole by means of a switch in 4201W-7, operated from the cross-cut.

* Note: See sec. L-9 for description of LSM-10 and LSM-11.

Beginning May 21, Obert recorders were used whenever possible, but the writer coils burned out one after another, so the LSM-11 was used for listening when the recorders were not available. The program continued until June 20. The writer arrived at Kirkland Lake on June 17, at which time the writer coils of the Obert recorders were all out of commission, as well as some of the six replacement coils Obert had furnished.

It was decided to discontinue the listening program on June 20 and to concentrate on getting new coils made and the Obert equipment operating as soon as possible. This was accomplished by June 30, when a regular program with the Obert recorders was begun on the 4200-ft. level in 4201W-7. The equipment was supplied with the A.C. mine electric service, which was specially wired out to this point, some 700 ft. west of the main cross-cut.

J-11 Analysis of Data Obtained in Listening Program

- (a) There was a marked difference between 3906E stope and 4201W-7 drift, the latter being much the more active location, in a ratio of about 10:1.
- (b) Blasting in the vicinity of the geophones markedly increased the count, many cracks following the blast.
- (c) The average of cracks per minute (C/M) is given in the following tables, but the number occurring in each successive minute varied greatly. For example, on June 20 the average for 60 min. was 5.7, but the number in any one minute varied as follows:

| C | O | C | O |
|---|----|----|----|
| 1 | 2 | 6 | 12 |
| 2 | 1 | 7 | 9 |
| 3 | 6 | 8 | 5 |
| 4 | 7 | 9 | 2 |
| 5 | 13 | 10 | 3 |

C = the number of snaps in a given minute.

O = the number of different minutes when the count was the number given in C.

- (d) Greater cracking activity preceded and immediately followed the one small burst experienced while actually listening in on the 4201W-7 post.
- (e) It was concluded that recording should be attempted in the vicinity of 4201W-7.

J-12 Summary of Listening Observations in Stope 3906E

November 5, 1941 to April 30, 1942

| Date | C/M | Date | C/M | Date | C/M | Date | C/M | Date | C/M | Date | C/M |
|------|-----|------|-----|------|-----|------|-----|------|------|------|-----|
| N5 | 3.2 | D 4 | .3 | J 2 | .5 | F 4 | 1.1 | M 5 | .9 | A 2 | 1.8 |
| 6 | 1.2 | 5 | .4 | 3 | .4 | 5 | B | 6 | 1.4 | 3 | 1.4 |
| (7) | .5 | 6 | .7 | 5 | 2.0 | 6 | .2 | 7 | 1.1 | 4 | 1.6 |
| (11) | .4 | 8 | .6 | 6 | 2.0 | 7 | 1.9 | 9 | .5 | 6 | .6 |
| 11 | 1.1 | 9 | .5 | 7 | .7 | 9 | C | 10 | .4 | 7 | .5 |
| (12) | 2.0 | 10 | .5 | 8 | 1.7 | 10 | 1.4 | 11 | 4.4H | 8 | 2.0 |
| 12 | 2.1 | 11 | .7 | 9 | .2 | 12 | D | 12 | 1.0 | 9 | J |
| (13) | .8 | 12 | 2.5 | 12 | .1 | 13 | .1 | 13 | .7 | 10 | .4 |
| 13 | 1.4 | 13 | .5 | 13 | A | 14 | .6 | 14 | .9 | 11 | J |
| 14 | 1.3 | 15 | 1.0 | 17 | .4 | 16 | E | 15 | G | 13 | .8 |
| 15 | .9 | 16 | .4 | 19 | 1.1 | 17 | .9 | 17 | .8 | 14 | 1.0 |
| 17 | 1.2 | 17 | 1.0 | 20 | .2 | 18 | .8 | 18 | 2.6I | 15 | 1.4 |
| 18 | 1.5 | 18 | .2 | 21 | .5 | 19 | F | 19 | .7 | 16 | .9 |
| 19 | .9 | 19 | 1.2 | 22 | 1.6 | 20 | 1.0 | 20 | 1.2 | 17 | 1.4 |
| 20 | 1.1 | 20 | .7 | 23 | .5 | 21 | .6 | 21 | 1.2 | 18 | .5 |
| 21 | .9 | 21 | .5 | 24 | .3 | 23 | G | 23 | 1.0 | 20 | 1.1 |
| 22 | .7 | 22 | 1.2 | 26 | .6 | 24 | .6 | 24 | 1.1 | 21 | 1.2 |
| 24 | .4 | 23 | .8 | 27 | .5 | 25 | .4 | 25 | .5 | 22 | 1.2 |
| 25 | .3 | 24 | .5 | 28 | .3 | 26 | .6 | 26 | 1.0 | 24 | .7 |
| 27 | 1.2 | 27 | 1.9 | 29 | 1.9 | 27 | .2 | 27 | .7 | 25 | .8 |
| 28 | 1.4 | 28 | .9 | 30 | .6 | 28 | .9 | 28 | 1.0 | 27 | .4 |
| 29 | 1.0 | 29 | 1.4 | 31 | 2.6 | M 2 | .7 | 30 | .3 | 28 | .1 |
| D2 | .4 | 30 | .9 | F 2 | .2 | 3 | .7 | 31 | .8 | 29 | .6 |
| 3 | .3 | 31 | 1.6 | 3 | 1.9 | 4 | .8 | A 1 | 1.4 | | |

Dates in brackets indicate observations made from 2:45 to 3:55 a.m.

- A Insensitivity traced to geophone (Obert's). Replaced by one made by Hallick, beginning January 17.
- B No blasting in stope, Only 6 snaps in 110 min.
- C New dual amplifier installed February 9.
- D Drill operating prevented good listening.
- E Replaced battery.
- F Geophone trouble spoiled record.
- G Crusher and conveyor running.
- H Several bursts heard in listening.

- I New section started in 3906E stope.
 J Listening by Gibbs. Testing Equipment.

J-13 Summary of Listening Observations in 4201W-7

May 1 to June 20, 1942

| Date | C/M | Date | C/M |
|------|------|------|-------|
| M 1 | 8.1 | M 27 | 3.7 |
| 2 | 6.4 | 28 | 9.2 |
| 4 | 5.6 | 29 | 3.2 |
| 5 | 4.1 | 30 | 7.5 |
| 6 | 2.9 | J 1 | 8.3 |
| 7 | 2.5 | 2 | 4.8 |
| 8 | 6.3 | 3 | # |
| 9 | 5.2 | 4 | 7.8 |
| 11 | 5.5 | 5 | 5.1 |
| 12 | 4.4 | 6 | 8.8 |
| 13 | 6.2* | 8 | 2.6 |
| 14 | 2.2 | 9 | 1.5 |
| 15 | 7.5 | 10 | 2.4 |
| 16 | 10.3 | 11 | 1.2 |
| 18 | 7.2 | 12 | .9 |
| 19 | 5.0 | 13 | 2.0 |
| 20 | 5.2 | 15 | 5.4 |
| 21 | 10.1 | 16 | 11.6+ |
| 22 | 7.0 | 17 | 3.8 |
| 23 | 9.0 | 18 | 5.7 |
| 25 | 7.3 | 19 | 5.3 |
| 26 | 8.3 | 20 | 5.7 |

* Heaviest snaps and greatest activity seemed to be in H4.

Testing and adjustment of equipment by Gibbs.

+ Small burst occurred during listening period, with great increase in activity.

J-14 Recommendations for Research Program

The development of the various geophysical programs undertaken at Lake Shore Mines had now reached a point where it was definitely established that a geophysical

characteristic (subaudible snapping) existed, and that it was probably indicative of strain conditions approaching burst proportions; also that the equipment available was adequate for a thorough study of this phenomenon in a selected section of the mine. The various phases of this problem had now to be studied intensively and persistently. The following recommendations were therefore submitted:

(a) Personnel:

That the responsibility for maintaining and adapting the equipment rest with Gibbs; that the problem of developing and carrying through an underground program be given to someone thoroughly interested and qualified to carry it through; and that Hallick be assigned to assist jointly in these closely related duties.

(b) Locale:

That the study be confined to the west pillar. Initially the investigations should cover both sides of that pillar throughout its entire elevation. As experience dictated, the study might later be directed more particularly to key points whose existence and position had become evident as the work progressed.

(c) Recording Equipment:

That shelters be provided on three levels to be selected, and that these be located in that part of the drift that is central to the pillar (within the stoped region). These shelters should be made as safe as is reasonably practical and supplied with 110-volt alternating current. From these shelters, lines could be run out to reach any selected point in the pillar, in drift or stopes.

(d) Listening Equipment:

That a light truck be designed and built to accommodate the battery-operated listening equipment, making it easily possible to reach, on any level, the holes to be drilled for geophone installation.

(e) Geophone Holes:

That a considerable number of drill holes be located by survey and run out into the solid. These should be located wherever strain conditions seem to be building up in any part of the pillar.

(f) Mapping of Mine Work:

That an isometric chart of the pillar be constructed for use as a base on which to plot the progress of the mine work in the pillar. A chart, brought up to date on, say, Friday

of each week should be made available to the geophysical services on Saturday.

(g) Recording Program:

That records be obtained regularly at each of the three recording stations for such times of the day and such points on the pillar as may be found desirable from day to day.

(h) Listening Program:

That some part of each working day be spent with the listening equipment in an endeavour to track down the active section or sections of the pillar and to determine whether they are stationary or migrate as mining progresses.

(i) Observing Program:

That the man appointed to take charge of the underground program devote sufficient time to become thoroughly familiar with every part of the pillar, the stopes as well as the drifts. He should have access to the reports of the shift bosses, who should be instructed to bring to his attention anything that, in their opinion, has any bearing on the problem of determining the strains on the pillar. As experience may indicate, the study of subaudible snapping should be supplemented by records of strain gauges, scratch plates, photographic repeats, etc.

(j) Reports:

That once a week a confidential report is to be submitted to the company, showing graphically the work done and the conclusions drawn to date, and adding such brief comments as seem necessary.

The above recommendations were presented on June 26, 1942, and were approved. Later, Mr. Blomfield asked the writer to develop and carry through the underground program, leaving Gibbs free to deal with the heavy and complex instrumental problems. Hallick was assigned to assist both, and the new program began as of July 1, 1942.

Report K

July 1 to December 31, 1942

In spite of the interruptions to service, the first six months of the reorganized program yielded most valuable data, which are presented in detail in this report.

K-1 Instrument Trouble(a) Writer Coils Burning Out:

When the program began on July 1, the chief trouble with the equipment was due to the burning out of the writer coils at a rate of nearly one a day for some weeks. It was found that the cause was the damp air charged with explosion fumes; this was remedied by installing a 50-watt lamp in each recorder box, since when no coil has burned out.

During the period when the coils were burning out, it was necessary to take at least one recorder to the surface nearly every day, with the result that for the first month there is little continuity of instrumental hook-up, as will be noted from the tabulated data given later in this report. The sets were designated 111, 222, and 333, keeping the three sets of three units each assembled as they were when received.

A complete statement of operating conditions requires one to give hole number, geophone number, and attenuation in decibels. This is usually abbreviated as: 222 H4 G2 D10, or in practice as: 222H4G2D10.

(b) Recording Paper Fires:

Soon after the program began, a series of fires occurred in the recording units, owing to the recording paper catching fire from the stylus. Sometimes the only result was the loss of a record. On other occasions, the plastic spools were burned and had to be replaced by wooden ones.

At first, fires were due to the recording running side ways on the recorder and so becoming warped up off the contact platen just enough to permit fires to start. Later, they were due to the traction of the drive roller being too slight to move the paper. When this was remedied by reducing back tension, the paper moved from the supply roller in jumps which lifted it from the platen and again caused fires.

Finally, on September 22, recorder 2C caught fire early in the morning and burned the unit badly. This fire threatened to spread in the recording room. The wooden recorder boxes were then replaced by ones made of steel, the drive rollers were made of

knurled brass (which tend to snuff out a smouldering record), and the C units were checked for alignment (and found to be quite badly out). When these points had been corrected the fires ceased.

(c) Other Instrument Troubles Encountered:

The following difficulties were not persistent, but cropped up erratically from time to time:

- (1) Shorting of the stylus to chassis by filaments of steel wool that were so small as to be almost invisible.
- (2) Failure of soldered joint holding stylus point on the arm. Some points also burned off.
- (3) Disintegration of geophone crystals owing to moisture penetrating the case.
- (4) Poor contacts at amphenol connectors.
- (5) Broken strands of shielded cable caused slight holes in casing, leading to infiltration of water and the development of electrolytic action, with resulting electrical disturbance (static) on the recording lines.
- (6) Burning out of radio tubes and a transformer, the latter of a type that could not be exactly duplicated (nearly all replacements at this time had to be more or less unsatisfactory substitutions).
- (7) Some record paper rolls were a shade too wide, resulting in a failure of the drive. Such rolls when found (usually only one in a package of ten) had to be discarded.
- (8) Voltage fluctuations in AC power line.

K-2 Listening Program

In order that the pillar might be surveyed as thoroughly as possible to locate strategic operating positions, a listening program was begun at once. From the beginning it was found necessary to do all the listening during the off-shift periods, but a sufficient length of time after blasting.

At first, listening was done with LSM-11 and LSM-12; these are amplifiers used with head sets, but not giving any record. Later, when the Obert recorders were connected by cable lines from the central recording rooms to widely distributed geophones that could be connected at will, it was found desirable to listen in over the Obert units, which furnished a record at the same time.

To permit the use of an extra listening set (LSM-11 or LSM-12) and get a record from one hole while recording on the Obert set from another, Gibbs devised an extra stylus, manually operated, for the Obert recorder. Using it, the operator listened over the extra set and recorded what he heard by means of the extra stylus on the Teledeltos paper of the Obert instrument, the extra stylus tracing an extra line on the record. The listening from one hole was thus recorded and correlated with the Obert record from another.

This procedure resulted in the operator attaining a most useful familiarity with the nature of the records. The timbre of the sound heard is often sufficient to permit the identification of the source, whereas the record gives much the same sort of response to many types of disturbance. It thus became possible to note the slight differences in the records and to know more about the nature of the activity from day to day.

K-3 Underground Recording Rooms and Layout of Drill Holes

Cable was run from the doghouse on 4206W-6 (Station B) to holes H4, H25, H19, and H20, all on the 4200-ft. level (for layout of holes see section K-6). Another line was run from station B down through the manway just to the west of the station to the flatback above 4301W-7. This served to connect H23, and later H24, to Station B. Another line was run west from B for about 185 ft. to the flatback above 4201W-7, thence up the manway at section line 8W to 4001W, and thence east to H27. Similar lines were run in 3801W, west from the station in 3801W-9 (Station C) to H22. The line was continued east for about 250 ft. to the manway about 30 ft. west of section line 6W, and to the flatback above 3901W-6. Here it was led west in the more southerly of the divided drifts (3908W-7) to H13 and H18.

After the conference with Obert, it was decided to drill a 30-ft. hole (H28) beside H25, another 30-ft. hole (H29) in 3801W-9, and a third 30-ft. hole (H30) in 3908W-6. These holes were to be connected to their respective stations and the program was to consist of regular daily runs from 4 to 5 and 6 to 7 a.m. and p.m. (see section K-8). There were to be two recorders at Station B, recording from two selected holes of the available list, H24-25-26-27-28. Listening was to be carried out in the other adjacent holes. There was to be one recorder at Station C, recording from H29, with listening from H30.

It was planned that a testing oscillator should be built by Gibbs to Obert's design, and that the recording sets should be calibrated and maintained at a selected, intercomparable standard of sensitivity, which was to be tested at regular intervals.

It was proposed also to build a capacity bridge to test, from the observing stations, the lines from the geophones, these being in place on the lines, the set-up in the hole not being disturbed.

It was further decided to wedge 7-ft. steel bars, 1 3/8" diameter, into 6-ft. holes drilled near each geophone position. On the end of each bar was to be mounted a tapping mechanism, to be designed and built by Gibbs, operated electrically from the station

concerned. The tappers were designed to give a slight kick to the buried geophone, which should record as an offset on the record. Though these offsets would differ for the different geophone holes, they should always be the same for any given hole, regardless of what geophone or recorder was being used. Gibbs also planned to build a shaking table to test and calibrate the geophones.

As the supply of shielded cable was strictly limited, arrangements were made to replace all lines by BXL cable and to run parallel to each line of BXL a line of style B wire, which could be used to operate the tappers.

In order that the coverage of the pillar might be greater with the limited equipment available, Gibbs was to design and build time switches, so that two geophones, in widely separated boreholes, could operate automatically for alternate half-hours on the same recorder.

K-4 Handling of Records

The records as taken from the Obert recorders consisted of rolled strips of Tele-deltos paper 2 inches wide and 30 ft. long. To permit the study of these records and to provide a means of ready reference to any point, equipment and procedure were designed to simplify the accordion-pleating of the strips so that they could be mounted in book form. Each book carried the serial number of the record, and was paginated with a numbering machine. Thus a reference to 30337B indicates an 8-inch section of Record No. 303, appearing on the right-hand side (B) of the book when opened at page 37.

K-5 Conclusions and Recommendations

The following conclusions and recommendations are based on the work done in this period:

- (a) It was clearly demonstrated that anything less than a 6-ft. hole is useless. The 30-ft. holes were quite satisfactory and seemed deep enough. It was proposed to adopt 30-ft. holes as standard for this work, and to have them cased for 6 to 8 ft., with the casing projecting at least one foot from the wall to provide an attachment for the tapper. It was found that the 100-ft. hole (H25) did not extend beyond the zone of compression. The bottom of this hole was sometimes more and sometimes less active than the bottom of the 30-ft. hole drilled beside it.
- (b) A sensitivity slightly less than that used during the period covered by this report should be adopted as standard.
- (c) Tapping on the north (foot) wall was not picked up by geophones on the south (hanging) wall at distances at all comparable with those over which tapping on the south wall was picked up by the same south-wall geophones. Geophones set in holes in the north wall on

several different levels have shown little or no ground activity either by listening or recording. When bursts occurred, it was the hangingwall that came in.

(d) The 'slow' tracks of the three Obert recorders proved of little value and, with coverage of the pillar with a sufficient number of geophones, they became even less important. The new recorders had two 'fast' tracks instead of one fast and one slow.

(e) A voltage regulator should be obtained for each observing station (doghouse).

(f) The making of records into books after they have been scanned, compared, and analysed has proved most valuable, rendering the data readily accessible for checking and comparisons as further ideas developed from later observations.

(g) Effective listening was impossible at Lake Shore except during off-shift hours. Continuous recording was possible at such times only. When activity in any region becomes acute, it is recommended that the recorders and geophones concerned be run on 24-hr. schedule in an effort to record up to and through a burst. When ground is not dangerously active, it seems sufficient to record for alternate half-hours from each geophone for the hours 3-7 a.m. and p.m. When records are run 24 hours a day, only the schedule hours may be used in the statistical study.

(h) Many small and some medium snaps (as recorded at the sensitivity level in use during the period under review) recorded on one geophone and not on another, and vice versa, when distances of 50 to 75 ft. separated the geophones. This was not a matter of relative sensitivity of equipment or of the efficiency of emplacement of the geophones. It sometimes occurred when the holes were only 25 ft. apart. However, some medium snaps were clearly shown to be simultaneous over several levels. The significance of these anomalies must await analysis of the records.

(i) All records taken on schedule hours should be retained, annotated, analysed, and made up into book form, and sections of 24-hr. runs not on schedule should be carefully labelled and dated, but kept in roll form, unless some part of them becomes important.

(j) In general, the ground about to burst (within a week or so) showed great subaudible activity, even when the walls did not 'talk'. Data to show whether this activity increases or falls off immediately prior to a burst were lacking. It was safe to say that the subaudible method clearly indicated the sections actively dangerous, but prediction of the time of a burst was not clearly demonstrated. It was hoped that an analysis of the records into large, medium, and small offsets might show prediction trends in one special group.

(k) Small pre-bursts occur in badly strained ground for some days prior to destructive pillar bursts. These are too small to register on the surface seismograph and, in fact, show a (probable) falling off in intensity at a distance of 70 ft. between adjacent geophones.

There seems to be no prediction of these bursts either by increase or decrease of activity at the geophone showing the best record. After-snaps are very numerous and continue for from half a minute to 5 minutes or more. Many of these are now recorded and several have been heard during the listening periods.

(l) An examination of the back records in conjunction with the records of the surface seismograph should be made as soon as possible to determine the shift of pressure after a burst. The small bursts occurring in strained ground and presumably indicating serious conditions have not been known to record on the surface seismograph; nor, except in one case, is there known to be any relation between a burst in one part of a pillar and a change in ground activity in another part.

(m) It seems probable that a section of a pillar not under strain at the moment might be suddenly subjected to critical strain within a few minutes by a heavy burst in the pillar either above or below it. Such a danger might be detected promptly if equipment designed for such emergencies were available.

(n) As soon as an Obert set is available for use on a mobile listening post, the listening program at the recording stations should be abandoned in favour of using the short time available each day in exploration over a greater section of the pillar.

(o) Steps should be taken to put in pipe conduits (1.5" diam. at least) from each level to adjacent levels throughout the pillar. Each time a rill is completed, a pipe conduit should be put in place before the fill is poured, unless a connection has already been made between the levels concerned.

(p) Some more direct and regular connection should be made between the progress of mining in the region under study and the activity of the ground as shown on the records. It is clear that much of the fluctuation in activity is due to the amount of powder used, the number of holes blasted, and the approach of the rill to the top and towards the pickup geophone. It is strongly recommended that steps be taken to make this mining information readily available in some simple routine manner for the regular use of the rockburst survey.

(q) A good deal of valuable equipment is maintained in the underground observing stations. The fact that it is vital to the work and almost irreplaceable makes it more valuable than its cost would indicate. Much of the time of trained observers is spent in these stations. In view of the experience so far gained, it is strongly urged that the stations should always be built:

- (i) Well in the fill region, with no part of the pillar between the doghouse and the cross-cut.
- (ii) Against the north (foot) wall.
- (iii) With timbers competent to take pressure, and sided with two-inch plank.

The station at 4201W-6 may be cited as an example of a satisfactory structure, except that it is built against the south wall.

(r) Until the calibration and standardization of the recorders and geophones is accomplished, and checking is done regularly as a routine procedure, the program will operate under a considerable handicap, since undisputed conclusions can never be drawn from the observations.

K-6 Test Holes Assigned to Rockburst Research

Test holes 1-30, drilled for use in the rockburst program during the period covered by this report, are plotted in plan and elevation in Figure 47. Plan and elevation have each a vertical scale indicated by the 125-ft. difference in the levels. The section lines on each chart indicate an east-west distance in intervals of 100 ft. In each diagram, west and east are respectively to the left and right as one faces the charts. In the projection of the plans, the oblique lines run down and to the left (south) and up and to the right (north), the scale division in each direction indicating 50 ft. The following table gives the drilling data for each hole and indicates its position in the mine.

| No. | PD or DD No. | Date | Location and Wall | Depth | Remarks |
|-----|--------------|--------|-------------------|-------|--------------------------------|
| 1 | PD | May | 4201W- 6-S | 6' 1" | Good hole, fairly solid rock. |
| 2 | PD | " | 4201W- 6-S | 3' 7" | Good hole in solid rock. A |
| 3 | PD | " | 4201W- 7-S | 4' 6" | Ground shattered. A |
| 4 | PD | " | 4201W- 7-S | 5' 2" | Good hole; solid rock. |
| 5 | PD | " | 4201W- 8-S | ? | B |
| 6 | PD | " | 4201W- 9-S | ? | B |
| 7 | DD | July 2 | 4201W- 9-S | 1' 0" | A, C, D |
| 8 | DD | " 2 | 4201W- 7-N | 3' 6" | Good hole, solid rock. A, D |
| 9 | PD | " 3 | 4001W- 7-S | 5' 0" | Tandem holes in fair condition |
| | | | | 5' 0" | when drilled. |

DOMINION OBSERVATORY

| No. | PD or DD No. | Date | Location and Wall | Depth | Remarks | |
|-----|-----------------|---------|----------------------|----------------|--|---------|
| 10 | PD | " 3 | 4001W- 8-N | 5' 0" | | E |
| 11 | PD | " 11 | 3801W- 8-S | 6' 1" 6' 4" | Tandem holes, in fair condition when drilled | |
| 12 | PD | July 11 | 3801W- 9-N | 6' 0" | Rough at inner end; solid. | |
| 13 | PD | " 11 | 3908W- 8-S | 5' 11" | Rough for 2', then good. | |
| 14 | PD | " 13 | 4301W- 7-S | 4' 10" | Rough. | |
| 15 | PD | " 13 | 4301W- 7-S | 5' 1" | Very rough for 2', then good | |
| 16 | PD | " 13 | 4301W - 8-S | 4' 9" | Broken ground 18" in the hole. | |
| 17 | PD | " 13 | 4001W- 8-S | 5' 0" | Broken ground; rough. | |
| 18 | PD | " 13 | 3908W- 7-S | 6' 0" | Irregular; wavy. | |
| 19 | PD | Aug. 7 | 4201W- 9-S | 6' 0" | Ground loose; beside H7. | |
| 20 | PD | " 7 | 4201W-10-N | 6' 1" | Good ground; smooth. | |
| 21 | DD-3679 | " 15 | 4201W- 7-S | 30' 0" | Beside H4 | F |
| 22 | PD | " 28 | 3801W- 9-S | 5' 4" 5' 4" | Very loose. Tandem holes, good at inner ends. | |
| 23 | DD | " 30 | 4301W- 7-S | 4' 6" | Good ground, | A, D, G |
| 24 | DD-3704 | Sep. 16 | 4301W- 7-S | 30' 3" | Near H15 | H |
| 25 | DD-3679 | " 22 | 4201W- 7-S | 103' 0" | Beside H4 | I, J |
| 26 | DD-3707 | " 23 | 4201W- 9-S | 30' 0" | Beside H7 and H19. | K |
| 27 | DD-3708 | " 23 | 4001W- 7-S | 29'10" | Beside H9. | L |
| 28 | DD-3735 | Oct. 28 | 4201W- 7-S | 29' 9" | Beside H4, H21, and H25. | M |

| No. | PD or DD No. | Date | Location and Wall | Depth | Remarks | |
|-----|-----------------|--------|----------------------|--------|-------------|---|
| 29 | DD-3742 | Nov. 5 | 3801W- 9-S | 30' 3" | Beside H22. | N |
| 30 | DD-3744 | " 6 | 3908W- 7-S | 29' 6" | Beside H18. | O |

A. Some PD (percussion drill) holes (and a few DD, or diamond drill holes mostly shallow) are 'bootlegs' left from earlier operations and were taken over for this program.

B. Original depth of this hole not known. The ground was very badly shattered when later breaking a rill from stope 4301W-7 and on November 6, when examined, the hole was quite blocked.

C. Clean, smooth DD bootleg in what was later found to be a slab of loose.

D. DD hole; number not known.

E. Hole blocked at depth of about 2 ft. when steel was pulled.

F. This hole was the first deep DD test hole. It was drilled right beside H4. The work was finished August 15 but the hole was not used until September 1. It was later deepened to 103 ft. and numbered H25. The ground is fairly good. Hole gave good results as H21.

G. Hole found in south wall of 4301W-7 stope, on flat-back.

H. DD-3704 (H24), begun September 16; finished September 16.

0' - 30'3" all porphyry.

0' - 8'3" core badly broken up. 14 pulls with 3" or 4" of ground core at each pull.

8'3" - 30'3" core not so badly broken up; rock jointed with planes about 3" or 4" apart.
12 pulls; no ground core.

No sludge.

I. See F. above. This hole was originally H21 (30 ft. deep). It was deepened to 103 ft. and given the number H25. The ground in the extension is very good.

J. DD-3679 (H25), begun September 17; finished September 22. Hole deepened from 30 ft. to 103 ft. Old hole (H21) required reaming 18 ins. at 2 ft. and 18 ins. at 10 ft.

30' - 31' shattered porphyry.

31' - 31'7" ground core.

31'7" - 37' porphyry badly broken up. Pieces average 2" long. 4 pulls.

37' - 61' porphyry not badly broken up. 9 pulls.

61' - 63'9" porphyry not shattered.

63'9" - 88'4" porphyry not shattered. 4 pulls.

88'4" - 103' porphyry not shattered; 3 pulls.

No sludge returned to collar of hole.

K. DD-3707 (H26), begun September 23; finished September 23.

0' - 19'9" porphyry core badly shattered. 18 pulls.

19'9" - 30' blocky porphyry. 7 pulls.

No sludge.

| Rec | Fr | To | ABC-G-Db | S | Mx | A | Mn | Remarks |
|-----|----|----|----------|-----|----|---|----|-------------------|
| | | Oc | | | | | | |
| 186 | 1 | 2 | 333 | 1 5 | a | 5 | 2 | 0 |
| 188 | 2 | 3 | 333 | 1 5 | a | 6 | 4 | 0 |
| 190 | 3 | 5 | 333 | 1 5 | b | 4 | 2 | 0 New schedule b. |
| 192 | 5 | 6 | 333 | 1 5 | b | 8 | 4 | 0 |

- A. Stylus writes very lightly.
- B. Record of a burst at 3:46 a.m., September 30. Compare note K' for H4. Activity greater for the remainder of the hour, then return to slight activity. No bursts are reported by the mine for this time, but burst 286C occurred in 1607W drift at 2:05 a.m., Sept. 30 and was well recorded on the surface seismograph. The burst at 3:46 a.m. does not appear on the surface seismogram, but it is undoubtedly a small burst not far from 4201W-7.

H4

| Rec | Fr | To | ABC-G-Db | S | Mx | Av | Mn | Remarks |
|-----|----|-------|----------|------|----|----|----|-----------|
| | | Jn J1 | | | | | | |
| 1 | 30 | 2 | 111 | 2 5 | a | - | - | - A, B |
| | | J1 | | | | | | |
| 2 | 2 | 4 | 111 | 2 0 | a | - | - | - A, B, C |
| 3 | 4 | 6 | 212 | 2 22 | a | 6 | 3 | 1 D |
| 7 | 8 | 9 | 211 | 2 22 | a | 18 | ? | 0 E, F |
| 8 | 9 | 10 | 223 | 2 15 | a | 35 | ? | 1 G, H |
| 9 | 10 | 11 | 223 | 2 15 | a | 15 | ? | 1 I |
| 11 | 11 | 13 | 223 | 2 20 | a | 4 | 2 | 0 J |
| 12 | 13 | 14 | 311 | 2 20 | a | - | - | - K |
| 13 | 14 | 15 | 222 | 2 20 | a | 2 | 1+ | 0 |
| 14 | 15 | 16 | 222 | 2 20 | a | 2 | 1+ | 0 |

DOMINION OBSERVATORY

| Rec | Fr | To | ABC-G-Db | S | Mx | Av | Mn | Remarks |
|-----|----|----|----------|------|----|----|----|---------|
| 15 | 16 | 17 | 222 | 2 15 | a | 2 | 1+ | 0 |
| 16 | 17 | 18 | 222 | 2 15 | a | 2 | 1+ | 0 |
| 19 | 18 | 20 | 313 | 2 2 | a | - | - | - K |
| 20 | 20 | 21 | 222 | 2 15 | a | 1 | 1- | 0 |
| 23 | 21 | 22 | 313 | 2 2 | a | 0 | 0 | 0 L |
| 26 | 22 | 23 | 222 | 2 10 | a | 2 | 1- | 0 |
| 30 | 23 | 24 | 313 | 2 2 | a | 2 | 1- | 0 M |
| 32 | 24 | 25 | 313 | 2 2 | a | - | - | - N |
| 36 | 25 | 25 | 313 | 2 2 | 0 | 2 | 1- | 0 O |
| 38 | 25 | 27 | 313 | 2 2 | a | - | - | - K |
| 42 | 29 | 30 | 111 | 2 10 | a | 34 | 9 | 1 P, Q |
| 43 | 30 | 31 | 222 | 2 5 | a | - | - | - R |
| | Ag | Ag | | | | | | |
| 45 | 1 | 3 | 222 | 2 5 | a | 15 | 4 | 1 |
| 47 | 3 | 4 | 222 | 2 5 | a | 6 | 3+ | 2+ S |
| 49 | 4 | 5 | 222 | 2 5 | a | - | - | - K |
| 52 | 5 | 6 | 222 | 2 5 | a | T | T | T T |
| 53 | 6 | 7 | 222 | 2 5 | a | 10 | 4 | 2 U |
| 55 | 7 | 8 | 222 | 2 5 | a | 10 | 5 | 3 |
| 57 | 8 | 10 | 222 | 2 5 | a | 7 | 4 | 3 |
| 59 | 10 | 11 | 222 | 2 5 | a | 6 | 4 | 1 |
| 62 | 11 | 12 | 222 | 2 5 | a | 5 | 2+ | 0 |

ROCKBURST RESEARCH 1938-45

109

| Rec | Fr | To | ABC-G-Db | S | Mx | Av | Mn | Remarks |
|-----|----|----|----------|-------|----|----|----|---------|
| 65 | 12 | 13 | 222 | 2 5 a | 14 | 5 | 2 | |
| 68 | 13 | 14 | 222 | 2 5 a | 6 | 3 | 2 | |
| 71 | 14 | 15 | 222 | 2 5 a | 6 | 3 | 0 | |
| 74 | 15 | 17 | 222 | 2 5 a | - | - | - | K |
| 77 | 17 | 18 | 222 | 2 5 a | 8 | 5 | 0 | V |
| 80 | 18 | 19 | 222 | 2 5 a | 8 | 6 | 1 | W |
| 83 | 19 | 20 | 222 | 2 5 a | 6 | 3 | 1 | |
| 86 | 20 | 21 | 222 | 2 5 a | 30 | 15 | 0 | W, X |
| 89 | 21 | 22 | 222 | 2 5 a | 14 | 8 | 0 | |
| 92 | 22 | 24 | 222 | 2 5 a | 12 | 6 | 0 | Y |
| 95 | 24 | 25 | 222 | 2 5 a | 5 | 3 | 0 | |
| 98 | 25 | 26 | 222 | 2 5 a | 5 | 3 | 0 | Z |
| 101 | 26 | 27 | 222 | 2 5 a | 20 | 10 | 5 | A' |
| 104 | 27 | 28 | 222 | 2 5 a | 6 | 4 | 0 | B' |
| 107 | 28 | 29 | 222 | 2 5 a | 6 | 4 | 2 | C' |
| 109 | 29 | 31 | 222 | 2 5 a | 5 | 3 | 0 | B' |
| | | | | Sp | | | | |
| 111 | 31 | 1 | 222 | 2 5 a | 3 | 2- | 0 | |
| | | | | Sp | | | | |
| 115 | 1 | 2 | 222 | 2 5 a | 12 | 5 | 1 | |
| 119 | 2 | 3 | 222 | 2 5 a | 18 | 7 | 2 | D' |
| 122 | 3 | 4 | 222 | 2 5 a | 12 | 5 | 2 | |

DOMINION OBSERVATORY

| Rec | Fr | To | ABC-G-Db | S | Mx | Av | Mn | Remarks |
|-----|----|----|----------|--------|----|----|----|---------|
| 125 | 4 | 5 | 222 | 2 5 a | 15 | 6 | 3 | A' |
| 128 | 5 | 7 | 222 | 2 5 a | 14 | 5 | 2 | E' |
| 131 | 7 | 8 | 222 | 2 5 a | 10 | 5 | 2 | A' |
| 134 | 8 | 9 | 222 | 2 5 a | 7 | 4 | 1 | |
| 136 | 9 | 10 | 222 | 2 5 F' | F' | F' | F' | F' |
| 138 | 10 | 11 | 222 | 2 5 a | 7 | 4 | 0 | |
| 140 | 11 | 12 | 222 | 2 5 a | 7 | 4 | 2 | |
| 142 | 12 | 13 | 222 | 2 5 a | 10 | 6 | 2 | A' |
| | Sp | Sp | | | | | | |
| 143 | 13 | 14 | 222 | 2 5 a | 8 | 5 | 1 | |
| 148 | 14 | 15 | 222 | 2 5 a | 7 | 4 | 1 | A' |
| 151 | 15 | 16 | 222 | 2 5 a | 11 | 6 | 1 | A' |
| 154 | 16 | 17 | 222 | 2 5 a | 10 | 5 | 1 | A' |
| 157 | 17 | 18 | 222 | 2 5 a | - | - | - | G' |
| 160 | 18 | 19 | 222 | 2 5 a | 6 | 4 | 1 | A' |
| 163 | 19 | 21 | 222 | 2 5 a | 6 | 4 | 1 | A' |
| 166 | 21 | 22 | 222 | 2 5 a | 6 | 3 | 0 | |
| 169 | 22 | 23 | 222 | 2 5 H' | - | - | - | H' |
| 172 | 23 | 24 | 111 | 2 5 a | 4 | 2- | 0 | I' |
| 174 | 24 | 25 | 111 | 2 5 a | 4 | 1- | 0 | J' |
| 175 | 25 | 26 | 111 | 2 5 a | 5 | 2 | 0 | |
| 177 | 26 | 28 | 111 | 2 5 a | 5 | 2 | 0 | |

ROCKBURST RESEARCH 1938-45

111

| Rec | Fr | To | ABC-G-Db | S | Mx | Av | Mn | Remarks |
|-----|----|----|----------|----|-----|-----|----|-----------------|
| 179 | 28 | 29 | 111 2 5 | a | 9 | 4 | 1 | |
| 181 | 29 | 30 | 111 2 5 | a | 12 | 5 | 2 | K' |
| | | | | | | | | Oc |
| 183 | 30 | 1 | 111 2 5 | a | 10 | 4 | 2 | |
| | | | | | | | | Oc |
| 185 | 1 | 2 | 111 2 5 | a | 9 | 4 | 2 | |
| 187 | 2 | 3 | 111 2 5 | a | 20+ | 10+ | 3 | |
| 189 | 3 | 5 | 111 2 5 | a | 25+ | 15+ | 5 | L' |
| 191 | 5 | 6 | 111 2 5 | b | 30+ | 15+ | 5 | New schedule b. |
| 193 | 6 | 7 | 111 2 5 | b | 15 | 10+ | 3 | |
| 195 | 7 | 8 | 111 2 5 | b | 40- | 15+ | 5 | M' |
| 197 | 8 | 9 | 111 2 5 | b | 15+ | 8+ | 3 | N' |
| 199 | 9 | 10 | 111 2 5 | b | 20+ | 10+ | 4 | O' |
| 201 | 10 | 12 | 111 2 5 | b | 20- | 10- | 3 | |
| 203 | 12 | 13 | 111 2 5 | b | 15+ | 8+ | 3 | |
| 205 | 13 | 14 | 111 2 5 | b | 15+ | 8+ | 3 | |
| 207 | 14 | 15 | 111 2 5 | P' | - | - | - | P' |
| 210 | 15 | 16 | 111 2 5 | P' | - | - | - | P' |
| 214 | 16 | 17 | 222 2 0 | b | 15+ | 8+ | 3 | Q' |
| 217 | 17 | 19 | 222 2 0 | b | 15+ | 8+ | 3 | Q', R' |
| 219 | 19 | 20 | 111 2 5 | b | 15+ | 8+ | 1 | S', T' |
| 221 | 20 | 21 | 111 2 5 | b | 10+ | 5+ | 3 | T' |

| Rec | Fr | To | ABC-G-Db | S | Mx | Av | Mn | Remarks |
|-----|----|----|----------|-------|-----|-----|----|---------|
| 223 | 21 | 22 | 111 | 2 5 b | 10+ | 5+ | 3 | T' |
| 225 | 22 | 23 | 111 | 2 5 b | 10+ | 5+ | 3 | U' |
| 227 | 23 | 24 | 111 | 2 5 b | 25+ | 10+ | 3 | V' |
| 230 | 24 | 26 | 222 | 2 0 b | 5 | 1+ | 0 | W' |
| 233 | 26 | 27 | 222 | 2 5 b | 5 | 2- | 0 | |
| 235 | 27 | 28 | 111 | 2 5 b | 10 | 5+ | 4 | X' |
| 237 | 28 | 29 | 111 | 2 5 b | 5+ | 4+ | 3 | Y' |
| 239 | 29 | 30 | 111 | 2 5 b | 5+ | 4+ | 3 | |
| 241 | 30 | 31 | 111 | 2 5 b | 5+ | 4+ | 3 | Z' |

- A. Only occasional small offsets.
- B. Very insensitive. Only small offsets at long intervals.
- C. Recorder coil burned out on 1C. Replaced 1A and 1C with 2A and 2C.
- D. Slow stylus burned out early on July 5.
- E. Sudden increased activity 3 a.m., July 9.
- F. The record on July 8 was averaging about 1 s.p.m. but when the set came on automatically and unchanged as to constants at 3 a.m., July 9 the activity had increased to about 18 s.p.m. It got down to about 2 s.p.m. by 7 a.m., July 9. July 8-9 was a Wednesday-Thursday.
- G. Sudden increased activity at 3 a.m., July 10.
- H. Again a greatly increased activity after the night shift blasting. Minimum by 7 a.m., July 10 was about 3 s.p.m.
- I. Increased activity less on second day.
- J. July 12 was a Sunday. Activity small.
- K. Record burned in service.
- L. Record absolute blank - instrument trouble.
- M. Just before 4 p.m. on July 23 the record ran crookedly and the remainder of the record is distorted but partly legible. It is clear that the normal activity was maintained.
- N. E.A.H. forgot to turn record on.
- O. Record ran 3-4 and 6-7 p.m., July 25 and was then changed Saturday evening, July 25, by E.A.H., after the burst at 11 a.m., July 25, in stope 4301W-9. Shortly after 6 p.m., July 25, the record ran crookedly but is legible. The activity in this 6' hole, some 300 ft. from the burst and closing off about 4 hr. previous, is markedly low. The attenuation was only 2Db.

- P. Marked increase in activity.
- Q. This is a marked increase in activity, but it is to be noted that the instrumental set-up was changed since the preceding records.
- R. Record lost unaccountably.
- S. Uniformly moderate activity.
- T. The activity through most of the record was about: Max. 6 s.p.m.; Av. 4 s.p.m.; Min. 2 s.p.m., but a succession of bursts registered from 3-4 a.m., August 6. See Note J for H7.
- U. First record in doghouse B (4201W-6).
- V. Some small bursts (?) registered shortly before 4 a.m., August 18.
- W. Activity diminishes through record.
- X. First definite evidence of ore skipping 3-4 a.m., August 21, in No. 4 shaft.
- Y. Activity on both styli.
- Z. Well-defined activity.
- A'. Definite evidence of ore skipping in No. 4 shaft, 3-4 a.m.
- B'. Activity began 6 p.m., August 26.
- C'. Definite evidence of ore skipping 3-4 p.m., August 28. Location not known.
- D'. Small burst about 4 p.m., September 2.
- E'. First tapping tests. When tapping done on south wall it registered very well, but not when done on north wall.
- F'. Record not turned on (E.A.H.) till 6 a.m. Then there was a Max. 7 s.p.m.; Av. 3 s.p.m.; Min. 1 s.p.m. Record ran 6-7 a.m., September 11.
- G'. AC supply plug left improperly inserted by Z.E.G. No record.
- H'. No record. Paper caught fire. Recorder badly burned. Set 222 taken to surface for extensive repairs.
- I'. Record that looks like a burst recorded for about 4 min. at about 6:55 p.m., September 23.
- J. Again evidence of activity at 6:55 p.m., September 24 which, coming at same time as previous day, discredits the assumption that the records were due to bursts. They do not resemble blasts, however; cause not known.
- K'. Record of what was almost certainly a burst at 3:46 a.m., September 30. Compare I' and J' note above. The activity during the 14 min. which remained of the record after the burst averaged about 55 s.p.m., but it was down to 10+ s.p.m. when the record came on again at 6 a.m. Compare note B for H3.
- L'. Paper stuck for a short time. Motor kept running and paper released.
- M'. Record ran simultaneously with No. 194, this one in the 6-ft. hole and No. 194 in the 100-ft. hole. The activity was great in both, slightly greater in H25 (the deeper hole) and the coincidences were surprisingly few.
- N'. First 'pull out' test between H25 and H4. Compare record of No. 198 in H25.
- O'. Character of record changed since previous day owing to adjustment of recorder. Lines now quite faint.
- P'. Record stuck and nearly caught fire. No record till 6 a.m., when E.A.H. began listening program. Traction was weak on the feed and the back tension too strong. The record would run when tested and then fail to start when turned on by the time clock.

- Q'. A most unusual sensitivity. Both stylus records alike in appearance. The s.p.m. count seems valid however. See note F for H25.
- R'. Very wide zero which almost moved the fast stylus to the edge of the record.
- S'. Activity low for the first hour, then back to the level reported in the s.p.m. columns.
- T'. Too much voltage on recording styli.
- U'. Fast stylus recording many of the offsets as double. Probably due to carbon on the writing point.
- V'. Paper ran crookedly much of the record. Edge burned off for nearly 6 min. beginning page 22704. Fortunately record did not catch fire, but smouldered out.
- W'. Recorder decidedly out of adjustment. More activity recorded on the slow stylus than on the fast one. Beginning 3 p.m., October 25, activity up to Max. 15+, Av. 4+, Min. O, but fell off again after an hour. Latter end of record seems good but activity very low -- about Av. 1.
- X'. Paper did not feed until E.A.H. began listening at 6 a.m. Many small holes burned in record, but no fire.
- Y'. First 40 min. of record show instrument insensitive, but a sudden return to normal recording at a time when no one was near the instruments. Normal recording continued throughout the remainder of the record.
- Z'. For further recording from 4201W-7, see tabulations for H25 and H28.

(Note: the above noted instances of the improper feeding of record paper, with burning of parts of the record, culminated in a serious fire in station B (4201W-6) on September 22. Improvements were introduced as soon as they could be completed, but the set 111 in H4 was not changed over until about the end of October.)

H7

| Rec | Fr | To | ABC-G-Db | S | Mx | Av | Mn | Remarks |
|-----|----|----|----------|--------|----|----|----|---------------------------------|
| | J1 | J1 | | | | | | |
| 24 | 21 | 22 | 131 | 1 10 a | 0 | 0 | 0 | Absolutely blank. Instruments. |
| 27 | 22 | 23 | 313 | 1 2 a | 3 | 1- | 0 | |
| 29 | 23 | 24 | 222 | 1 10 a | 5 | 1 | 0 | A |
| 31 | 24 | 25 | 222 | 1 10 a | 5 | 2+ | 1 | |
| 35 | 25 | 25 | 222 | 1 10 B | 27 | 6 | 3 | B |
| 37 | 25 | 27 | 222 | 1 7 C | 20 | 15 | 6 | C |
| 39 | 27 | 28 | 222 | 1 5 a | 30 | 15 | 10 | Marked activity, entire record. |

| Rec | Fr | To | ABC-G-Db | S | Mx | Av | Mn | Remarks |
|-----|----|----|----------|------|------|----|----|--|
| 40 | 28 | 29 | 222 1 | 5 a | 30 | 10 | 3 | D |
| 41 | 29 | 30 | 222 1 | 5 a | 23 | 8 | 4 | E |
| 44 | 30 | 31 | 111 1 | 10 a | 135+ | 50 | 25 | F |
| | Ag | Ag | | | | | | |
| 46 | 1 | 3 | 111 1 | 10 a | 150+ | 50 | 25 | G |
| 48 | 3 | 4 | 111 1 | 10 a | 85+ | H | H | H |
| 50 | 4 | 5 | 111 1 | 10 a | 70 | I | I | I |
| 51 | 5 | 6 | 111 1 | 10 a | 50+ | J | J | J |
| 54 | 6 | 7 | 111 1 | 10 a | - | - | - | K Recording changed to H19, at 6-ft. hole drilled in south wall right beside H7. |

- A. A series of small continuous bursts from 6:32 p.m., July 23 to the shutting off of the record at 7 p.m. When the record came on again at 3 a.m., July 24, it was again normal with a maximum of about 5 s.p.m. and an average of less than 1 s.p.m.
- B. The stope nearest H7 (4301W-9) burst at a little after 11 a.m., July 25. The record was changed by E.A.H. at 8 p.m., July 25, so ran only 3-4 and 6-7 p.m. on July 25. The activity was marked. It is to be noted that H7 is only a foot deep and was later found to be in a large slab of loose.
- C. Activity markedly greatest beginning 3 p.m., July 26. By 6 a.m., July 27, after a Sunday of no mining, the record was down to an average of less than 1 s.p.m.
- D. Activity began to be great at 3 a.m., July 29. During the p.m. runs on July 28, it was an average of about 5 s.p.m.
- E. Activity began to be great at 3 a.m., July 30. During the p.m. runs on July 29, it was an average of about 5 s.p.m. A small burst registered 3:28 a.m., July 30, and a larger one, recording for more than a minute, registered at 3:43 a.m., July 30.
- F. Marked activity throughout record. Burst about 6:31 p.m., July 31, recorded for nearly two minutes.
- G. Very marked activity began 3 a.m., August 2, and gradually diminished over the week-end, August 2 being Sunday. Most of the activity was small and on the fast stylus but there were about 2 s.p.m. on the average of strong throws on both. In spite of the very marked activity there were no bursts.

- H. Record began very actively with average of more than 75 s.p.m. The activity fell off gradually during the recording.
- I. Beginning with an activity of about 25 s.p.m. on the average, all small, the activity increased during the period 6-7 p.m., August 4. From 6:50 to 6:53, three small bursts recorded. Two others of short duration but strong offsets occurred at 3:10 and 3:18 a.m., August 5, and a succession of these followed almost continuously till 4 a.m., when normal strong activity was resumed to the end of the record.
- J. Abnormal activity began 3 a.m., August 6, and continued till the closing off at 4 a.m. A succession of severe bursts occurred. Normal strong activity was resumed at 6 p.m., August 6. See note T for H4.
- K. Entire record open circuit oscillations.

H8

| Rec | Fr | To | ABC-G-Db | S | Mx | Av | Mn | Remarks |
|-----|----|----|----------|---|----|----|----|---------|
| | J1 | J1 | | | | | | |
| 10 | 10 | 11 | 312 5 0 | a | 2+ | 1- | 0 | A |
| 17 | 17 | 18 | 313 5 2 | a | 1+ | 1- | 0 | |
| 18 | 18 | 20 | 222 5 15 | a | 1- | 1- | 0 | B |
| 21 | 20 | 21 | 313 5 2 | a | 1- | 0 | 0 | C |
| 22 | 21 | 22 | 222 5 15 | a | 1+ | 1- | 0 | |
| 25 | 22 | 23 | 131 5 2 | a | 1 | 0 | 0 | D |
| 28 | 23 | 24 | 131 5 0 | a | 0 | 0 | 0 | E |
| 33 | 24 | 25 | 131 5 0 | a | 1 | 1- | 0 | F |
| 34 | 25 | 25 | 131 5 0 | H | 0 | 0 | 0 | G, H |

- A. Slow stylus coil burned out July 11.
- B. Very little on entire record.
- C. Record almost complete blank.
- D. One snap only on entire record.
- E. Record absolutely blank. Instrument trouble?
- F. Very little activity. Instrument OK.
- G. No activity recorded.

- H. The instrument was in good order so far as is known, but no activity was recorded. It ran 3-4 and 6-7 p.m., July 25. After the burst in 4301W-9 stope the record was removed by E.A.H., Saturday evening, July 25.

H9

| Rec | Fr | To | ABC-G-DB | S | Mx | Av | Mn | Remarks | | |
|-----|----|----|----------|---|----|----|------|---------|-----|-------------------------|
| | Ag | Ag | | | | | | | | |
| 87 | 20 | 21 | 111 | 5 | 5 | a | 20 | 15 | 2 | A |
| 90 | 21 | 22 | 111 | 5 | 5 | a | 100+ | 60 | 30 | B |
| 93 | 22 | 24 | 111 | 5 | 10 | a | 100+ | C | C | C |
| 96 | 24 | 25 | 111 | 5 | 5 | a | 25+ | 15 | 5 | Mostly small amplitude. |
| 99 | 25 | 26 | 111 | 5 | 5 | a | 30+ | 20 | 10 | Well defined activity. |
| 102 | 26 | 27 | 111 | 5 | 5 | a | 25+ | 15 | 10 | |
| 105 | 27 | 28 | 111 | 5 | 5 | a | 50+ | 25 | 10 | D |
| 108 | 28 | 29 | 111 | 5 | 5 | a | 50+ | 25 | 10 | E |
| | Sp | | | | | | | | | |
| 113 | 31 | 1 | 111 | 5 | 5 | a | 20 | 15 | 10 | |
| | Sp | | | | | | | | | |
| 116 | 1 | 2 | 111 | 5 | 5 | a | 8 | 5 | 1 | F |
| 158 | 17 | 18 | 111 | 5 | 5 | a | 50+ | 30+ | 20+ | G |
| 161 | 18 | 19 | 111 | 5 | 5 | a | 100+ | 75+ | 50+ | H |
| 164 | 19 | 21 | 111 | 5 | 5 | a | 40+ | 25+ | 15+ | I |

- A. Activity diminished through record.
 B. Activity diminished very little.

- C. Strong activity as indicated from 3-4 p.m., August 22, then markedly less over the week-end. Only 1 to 2 s.p.m. towards end of record. Compare note H for H19.
- D. Strong activity began 3 a.m., August 28. Previously quite moderate.
- E. Activity increased slightly 3 a.m., August 29.
- F. No evidence of anything like static.
- G. Slow stylus coil shorted to chassis by bit of steel wool. Not recording after first half hour. Strong activity on fast stylus seems real.
- H. Strong activity seems real.
- I. Definite falling off of activity (Saturday-Sunday).

H11

| Rec | Fr | To | ABC-G-Db | S | Mx | Av | Mn | Remarks |
|-----|----|----|----------|------|----|----|------|------------------|
| | | | Ag | Ag | | | | |
| 111 | 29 | 31 | 333 | 1 10 | a | 8 | 4 0 | A |
| | | | Sp | | | | | |
| 114 | 31 | 1 | 333 | 1 5 | a | 20 | 10 5 | |
| | | | Sp | | | | | |
| 117 | 1 | 2 | 333 | 1 10 | a | 12 | 6 0 | Very wide zeros. |

- A. The geophone was placed in H11 by F.J.H. in mistake for H22, which accounts for the short run on this hole. This is the first recording done on 3801W.

H19

| Rec | Fr | To | ABC-G-Db | S | Mx | Av | Mn | Remarks |
|-----|----|----|----------|------|----|------|-------|---------|
| | | | Ag | Ag | | | | |
| 56 | 7 | 8 | 111 | 1 10 | a | 200+ | A A A | |
| 58 | 8 | 10 | 111 | 1 10 | a | 65+ | B B B | |
| 60 | 10 | 11 | 111 | 4 10 | a | 100+ | C C C | |
| 64 | 11 | 12 | 333 | 4 5 | a | 20 | 10 2 | D |
| 67 | 12 | 13 | 333 | 4 5 | a | 15 | 10 3 | D |

| Rec | Fr | To | ABC-G-Db | S | Mx | Av | Mn | Remarks |
|-----|----|----|----------|---|----|------|--------|-----------------------------|
| 70 | 13 | 14 | 333 4 | 0 | a | 25 | 10 3 | D |
| 73 | 14 | 15 | 333 1 | 0 | a | 36 | 15 5 | E; much small amplitude. |
| 76 | 15 | 17 | 333 1 | 0 | a | 100+ | F F F | |
| 79 | 17 | 18 | 333 1 | 0 | a | 50+ | 25 15 | Mostly small amplitude. |
| 82 | 18 | 19 | 333 1 | 0 | a | 70+ | 25 15 | Mostly small amplitude. |
| 85 | 19 | 20 | 333 1 | 0 | a | 100+ | 50+ 25 | G; strong activity. |
| 88 | 20 | 21 | 333 1 | 5 | a | 150+ | 60+ 40 | Strong activity throughout. |
| 91 | 21 | 22 | 333 1 | 5 | a | 75+ | 40+ 25 | Strong activity throughout. |
| 94 | 22 | 24 | 333 1 | 5 | a | 150+ | H H H | |
| 97 | 24 | 25 | 333 1 | 5 | a | 75 | 25 10 | D; mostly small. |
| 100 | 25 | 26 | 333 1 | 5 | a | 85 | 30 15 | Mostly small. |
| | Sp | Sp | | | | | | |
| 155 | 16 | 17 | 111 3 | 5 | a | 60 | 30 20 | I; slow coil burned out. |

- A. For earlier recording from this same position see the report for H7, which is right beside H19. The former is only about a foot deep, while the latter is 6 ft. deep. This is the first recording from H19. Activity is very great throughout. During the latter part of the period 3-4 a.m., August 8, a succession of bursts is recorded.
- B. Activity was moderately strong on August 8. Beginning 3 p.m., August 9 (Sunday), strong activity was begun which continued, diminishing only slightly, to the end of the record.
- C. Moderately active to 3 a.m., August 11, when the activity became very marked, diminishing only slightly to the end of the record.
- D. The small frequent activity of these records may be instrumental, owing to non-grounding of centre tap of the geophone transformer.
- E. Installed internal transformer on G1. (Note that the recorded activity did not fall off, on the contrary it increased, which seems to nullify the suspicion of note D above.)

- F. Marked activity from beginning of record, diminishing towards the end of record which covers a week-end.
- G. Small burst 3:12 a.m., August 20.
- H. Very great activity 3-4 p.m., August 22. It then diminishes gradually over the week-end to about 10 s.p.m., all small, on August 24. Compare note A for H9.
- I. Decided change in character of record beginning 3 a.m., the amplitude being greater. Slow coil burned out 3:42 a.m.

H20

| Rec | Fr | To | ABC-G-Db | S | Mx | Av | Mn | Remarks |
|-----|----|----|----------|---|------|----|----|-------------------------------|
| | Ag | Ag | | | | | | |
| 61 | 10 | 11 | 333 6 5 | a | 1 | 0+ | 0 | Very quiet; hole in N wall. |
| 63 | 11 | 12 | 111 6 10 | a | 15 | 3 | 0 | A |
| 66 | 12 | 13 | 111 6 5 | a | 150+ | 50 | 40 | B |
| 69 | 13 | 14 | 111 6 10 | a | 38 | 25 | 10 | C |
| 72 | 14 | 15 | 111 6 10 | a | 15 | 10 | 0 | Small amplitude; diminishing. |
| 75 | 15 | 17 | 111 6 10 | a | 15 | 5 | 0 | Nearly all on fast stylus. |
| 78 | 17 | 18 | 111 6 10 | a | 10 | 4 | 0 | All small amplitude. |
| 81 | 18 | 19 | 111 6 5 | a | 20 | D | D | D |
| 84 | 19 | 20 | 111 6 5 | a | 20 | 15 | 10 | Activity small, continuous. |

- A. Some activity of small amplitude on fast stylus, beginning 3 a.m., August 12, but died down soon.
- B. Mostly small-amplitude activity on fast stylus only. This and the activity on the previous record may be static due to non-grounding of centre tap on geophone transformer; also, cable not shielded. (Note: trouble began to show up about this time from poor cable and from weathered joints, which had to be found and repaired when the evidence of their presence was found on the records.)
- C. Small-amplitude activity. Markedly greater, beginning at 3 a.m., August 14.
- D. Activity, all small, confined to 3-4 p.m., August 18.

H21

| Rec | Fr | To | ABC-G-Db | S | Mx | Av | Mn | Remarks | | |
|-----|----|----|----------|---|----|----|-----|---------|-----|-----------------------------|
| Sp | | Sp | | | | | | | | |
| 120 | 2 | 3 | 111 | 4 | 5 | a | 15 | 8 | 1 | First record in a 30' hole. |
| 123 | 3 | 4 | 111 | 4 | 5 | a | 12 | 8 | 2 | |
| 126 | 4 | 5 | 111 | 4 | 5 | a | 40+ | 20+ | 10+ | A |
| 129 | 5 | 7 | 111 | 4 | 5 | a | 30+ | 15+ | 6+ | Tapping test. |
| 132 | 7 | 8 | 111 | 4 | 5 | a | 30- | 15- | 6- | |
| 135 | 8 | 9 | 111 | 4 | 5 | a | 30- | 15- | 6- | A |
| 137 | 9 | 10 | 111 | 4 | 5 | a | 30+ | 15+ | 6+ | B |
| 139 | 10 | 11 | 111 | 4 | 5 | a | 15 | 8 | 3 | Good clean record. |
| 140 | 11 | 12 | 111 | 4 | 5 | a | 15 | 8 | 3 | A, C |
| 144 | 12 | 13 | 111 | 4 | 5 | a | 9 | 7 | 1 | D |
| 145 | 13 | 14 | 111 | 4 | 5 | a | 9 | 7 | 1 | |
| 149 | 14 | 15 | 111 | 4 | 5 | a | 15 | 9 | 2 | D |
| 152 | 15 | 16 | 111 | 4 | 5 | a | 18 | 9 | 2 | D, E |

- A. Very pronounced evidence of skipping on Shaft No. 4. The first noticed in the 30-ft. hole at 3-4 a.m.
- B. Skipping very pronounced 3-4 a.m. Also what seems to have been a burst, lasting about 2 min. at 3:48 a.m.
- C. Much quieter 3-4 p.m., September 11. Also 6-7 p.m. the same date. Activity was resumed at 3-4 a.m., September 12.
- D. Skipping very pronounced 3-4 a.m.
- E. This hole was deepened from 30 ft. to 103 ft. on September 22. Operating began on October 6 from the deepened hole, renumbered H25.

DOMINION OBSERVATORY

H22

| Rec | Fr | To | ABC-G-Db | S | Mx | Av | Mn | Remarks | | |
|-----|----|----|----------|---|----|----|----|---------|---|--------------------|
| Sp | | Sp | | | | | | | | |
| 118 | 2 | 3 | 333 | 1 | 10 | a | 5 | 1- | 0 | Wide zero. |
| 122 | 3 | 4 | 333 | 1 | 10 | a | 5 | 1- | 0 | |
| 124 | 4 | 5 | 333 | 1 | 5 | a | 10 | 4 | 2 | A |
| 127 | 5 | 7 | 333 | 1 | 5 | a | 7 | 3 | 2 | B |
| 130 | 7 | 8 | 333 | 1 | 5 | a | 10 | 5 | 3 | B |
| 133 | 8 | 9 | 333 | 1 | 5 | a | - | - | - | C |
| 146 | 12 | 14 | 333 | 1 | 5 | a | - | - | - | D, E |
| 147 | 14 | 15 | 333 | 1 | 5 | a | 3 | 1 | 0 | F |
| 150 | 15 | 16 | 333 | 1 | 5 | a | 2 | 1- | 0 | |
| 153 | 16 | 17 | 333 | 1 | 5 | a | 2 | 1- | 0 | G |
| 156 | 17 | 18 | 333 | 1 | 5 | a | 2 | 1- | 0 | |
| 159 | 18 | 19 | 333 | 1 | 5 | a | 2 | 1- | 0 | |
| 162 | 19 | 21 | 333 | 1 | 5 | a | 2 | 1- | 0 | H |
| 165 | 21 | 22 | 333 | 1 | 5 | a | 2 | 1- | 0 | |
| 168 | 22 | 23 | 333 | 1 | 5 | a | I | 1- | 0 | I |
| 171 | 23 | 24 | 333 | 1 | 5 | a | 2 | 1- | 0 | Wide zero. |
| 173 | 24 | 25 | 333 | 1 | 5 | a | J | 1- | 0 | J * |
| Oc | | Oc | | | | | | | | |
| 209 | 15 | 16 | 333 | 3 | 0 | b | 3 | 1- | 0 | K; new schedule b. |

| Rec | Fr | To | ABC-G-Db | S | Mx | Av | Mn | Remarks | | |
|-----|----|----|----------|---|----|----|----|---------|---|------------|
| 212 | 16 | 17 | 333 | 3 | 0 | b | 4 | 1 | 0 | Wide zero. |
| 215 | 17 | 19 | 333 | 3 | 0 | b | 4 | 1 | 0 | L |
| 218 | 19 | 20 | 333 | 3 | 0 | b | 4 | 1+ | 0 | |
| 220 | 20 | 21 | 333 | 3 | 0 | b | 4 | 1+ | 0 | M |
| 222 | 21 | 22 | 333 | 3 | 0 | N | - | - | - | N |
| 224 | 22 | 23 | 333 | 3 | 0 | b | 3 | 1- | 0 | |
| 226 | 23 | 24 | 333 | 3 | 0 | b | 4 | 1+ | 0 | |
| 228 | 24 | 26 | 333 | 3 | 0 | b | 2 | 1- | 0 | O |
| 231 | 26 | 27 | 333 | 3 | 0 | b | 2 | 1- | 0 | |
| 234 | 27 | 28 | 333 | 3 | 0 | b | 2 | 1- | 0 | |

- A. Mostly small; wide zero.
- B. Many small offsets on fast stylus increase during progress of record. Zero very wide. The numerous small offsets possibly due to instrumental trouble. First tapping tests on walls made on this record. They were well marked when done on south wall, but little or nothing showed when done on the north wall.
- C. Record not turned on (E.A.H.)
- D. Record valueless.
- E. First hour of record, continuous oscillations as if a circuit were open. Then wide zero for remainder of record. Some line trouble apparently.
- F. Zero still too wide.
- G. Second half of record shows an increased activity at the rate of 11-12 s.p.m., but it seems probable that the record is the result of instrument trouble. This is especially true since the next record (R156) shows a return to slight activity.
- H. Instrument seems OK.
- I. Only first two periods recorded; recorder out of order.
- J. Only first period recorded. Recorder 3C taken to surface for adjustment.
- K. Record shows very poor pickup. May be instrumental but possibly due to poor rock condition.
- L. Wide zero continued to 3 p.m., October 18, when an open circuit recorded with a few small interruptions for two hour-records, after which the wide zero was resumed.

DOMINION OBSERVATORY

- M. Too much voltage on slow stylus. Towards the last half of the record considerable very small activity recorded on the fast stylus only. May be instrumental.
- N. The record paper did not run, owing to slippage in drive. No record.
- O. The record showed very small activity, as reported in the s.p.m. columns, except for the period 3-4 p.m., October 25, when it ran: Mx 8; Av. 4, and Mn 1, after which the low activity was resumed. Zero was too wide throughout, but especially during the active hour.

H23

| Rec | Fr | To | ABC-G-Db | S | Mx | Av | Mn | Remarks |
|-----|----|----|----------|---|----|----|----|---------|
|-----|----|----|----------|---|----|----|----|---------|

| Ag | Ag |
|----|----|
|----|----|

| | | | | | | | | |
|-----|----|----|----------|---|----|----|----|------|
| 103 | 26 | 27 | 333 1 10 | a | 25 | 10 | 10 | A, B |
|-----|----|----|----------|---|----|----|----|------|

| | | | | | | | | |
|-----|----|----|----------|---|----|----|----|---|
| 106 | 27 | 28 | 333 1 10 | a | 40 | 30 | 10 | B |
|-----|----|----|----------|---|----|----|----|---|

| | | | | | | | | |
|-----|----|----|---------|---|----|----|----|--|
| 110 | 29 | 31 | 111 6 5 | a | 25 | 15 | 10 | |
|-----|----|----|---------|---|----|----|----|--|

A. Mostly small, possibly instrumental in part.

B. Definite evidence of ore skipping 3-4 a.m.

H24

| Rec | Fr | To | ABC-G-Db | S | Mx | Av | Mn | Remarks |
|-----|----|----|----------|---|----|----|----|---------|
|-----|----|----|----------|---|----|----|----|---------|

| Dc | Dc |
|----|----|
|----|----|

| | | | | | | | | |
|-----|---|---|----------|---|----|----|---|---|
| 306 | 7 | 8 | 111 3 10 | b | 5+ | 2+ | 0 | A |
|-----|---|---|----------|---|----|----|---|---|

| | | | | | | | | |
|-----|----|----|----------|---|-----|-----|---|--|
| 318 | 11 | 12 | 111 3 10 | b | 15- | 10- | 2 | |
|-----|----|----|----------|---|-----|-----|---|--|

| | | | | | | | | |
|-----|----|----|----------|---|----|----|---|--|
| 321 | 12 | 14 | 111 3 10 | b | 5+ | 3+ | 0 | |
|-----|----|----|----------|---|----|----|---|--|

| | | | | | | | | |
|-----|----|----|----------|---|----|----|---|--------------------|
| 324 | 14 | 15 | 111 3 10 | c | 5+ | 3+ | 0 | B; new schedule c. |
|-----|----|----|----------|---|----|----|---|--------------------|

| | | | | | | | | |
|-----|----|----|----------|---|-----|-----|---|---|
| 330 | 16 | 17 | 111 3 10 | c | 15+ | 10- | 3 | C |
|-----|----|----|----------|---|-----|-----|---|---|

| | | | | | | | | |
|-----|----|----|----------|---|-----|-----|---|--|
| 333 | 17 | 18 | 111 3 10 | b | 20+ | 10- | 0 | |
|-----|----|----|----------|---|-----|-----|---|--|

| | | | | | | | | |
|-----|----|----|----------|---|-----|-----|---|--------------------|
| 336 | 18 | 19 | 111 3 10 | d | 30+ | 10+ | 0 | D; new schedule d. |
|-----|----|----|----------|---|-----|-----|---|--------------------|

| | | | | | | | | |
|-----|----|----|----------|---|---|---|---|---|
| 338 | 19 | 21 | 333 3 10 | c | - | - | - | E |
|-----|----|----|----------|---|---|---|---|---|

| | | | | | | | | |
|-----|----|----|----------|---|-----|-----|----|---|
| 340 | 21 | 22 | 333 3 10 | b | 20- | 10- | 5- | F |
|-----|----|----|----------|---|-----|-----|----|---|

| Rec | Fr | To | ABC-G-Db | S | M | Av | Mn | Remarks | |
|-----|----|----|----------|---|----|----|-----|----------|-------------------------|
| 342 | 22 | 23 | 333 | 3 | 10 | d | 20- | 10- 5- | |
| 344 | 23 | 24 | 333 | 3 | 10 | d | 40- | 20+ 20- | |
| 346 | 24 | 28 | 333 | 3 | 10 | d | 10+ | 10- 5+ G | |
| | | Ja | | | | | | | Starting January, 1943. |
| 358 | 31 | 2 | 333 | 3 | 7 | d | 15+ | 10- 5- | |

- A. Friction of writing stylus with record much too great.
- B. Time switch installed to run H24 and H26 each alternate half-hour from 4-7 a.m. and p.m., with H24 coming on at the hour and H26 at the half hour. But the time switch did not close properly, so that it was always open circuit for H26 with much oscillation and no record.
- C. Last half of record was entirely lost, owing to open circuit oscillations.
- D. Last half of record shows noticeable falling off in activity.
- E. Entire record lost, owing to ineffective contacts on the time switch.
- F. Considerable time lost, owing to ineffective contacts on the time switch.
- G. Activity increased; at end of record about Av. 30+.

H25

| Rec | Fr | To | ABC-G-Db | S | Mx | Av | Mn | Remarks | |
|-----|----|----|----------|---|----|----|-----|---------------------------------------|--|
| | Oc | Oc | | | | | | | |
| 194 | 6 | 7 | 333 | 4 | 0 | b | 40+ | 20+ 10+ A; first record in 100' hole. | |
| 196 | 7 | 8 | 333 | 4 | 0 | b | 50+ | 25+ 15+ | |
| 198 | 8 | 9 | 333 | 4 | 0 | b | 40+ | 20+ 10+ B | |
| 200 | 9 | 10 | 333 | 4 | 0 | b | 40- | 20- 10- | |
| 202 | 10 | 12 | 333 | 4 | 0 | b | 40+ | 20+ 10+ C | |
| 204 | 12 | 13 | 333 | 4 | 0 | b | 20+ | 15+ 10+ D | |
| 206 | 13 | 14 | 333 | 4 | 0 | b | 20- | 15- 10- E | |
| 208 | 14 | 15 | 333 | 4 | 0 | b | 40+ | 20+ 10+ | |

DOMINION OBSERVATORY

| Rec | Fr | To | ABC-G-Db | S | Mx | Av | Mn | Remarks |
|-----|----|----|----------|---|-----|-----|-----|---------|
| 211 | 15 | 16 | 222 4 10 | b | 15+ | 10+ | 5+ | F |
| 213 | 16 | 17 | 111 4 5 | b | 50+ | 30+ | 15+ | |
| 216 | 17 | 19 | 111 4 5 | b | 40+ | 20+ | 10+ | G |
| 229 | 24 | 26 | 111 4 5 | b | 2 | 1- | 0 | H |
| 232 | 26 | 27 | 111 4 5 | b | 3 | 1- | 0 | I |
| Nv | | | | | | | | |
| 242 | 31 | 2 | 333 6 5 | b | 10- | 5+ | 1 | J |
| Nv | | | | | | | | |
| 245 | 2 | 3 | 111 4 5 | b | 20+ | 15+ | 5+ | |
| 247 | 3 | 4 | 111 4 5 | b | 20+ | 15+ | 5+ | K |
| 248 | 4 | 5 | 333 4 0 | b | 10- | 5+ | 1 | L, M, N |
| 251 | 5 | 6 | 111 4 5 | b | 20+ | 15+ | 5+ | |
| 253 | 6 | 7 | 111 4 5 | b | 15+ | 10- | 3 | |
| 255 | 7 | 9 | 111 4 5 | b | 15+ | 10- | 3 | |
| 257 | 9 | 10 | 111 4 5 | b | 10- | 5+ | 3 | O |
| 259 | 10 | 11 | 111 4 5 | b | 10+ | 5+ | 3 | O |
| 261 | 11 | 12 | 111 4 5 | b | 5 | 1+ | 0 | |
| 263 | 12 | 13 | 111 4 5 | b | 10- | 5+ | 2 | O |
| 265 | 13 | 14 | 111 4 5 | b | 20- | 10+ | 4 | O |
| 267 | 14 | 16 | 111 4 5 | b | 20- | 10+ | 3 | O |
| 269 | 16 | 17 | 111 4 5 | b | 15+ | 10- | 5 | P |
| 271 | 17 | 18 | 111 4 5 | b | 10+ | 5+ | 3 | O |

| Rec | Fr | To | ABC-G-Db | S | Mx | Av | Mn | Remarks |
|-----|----|----|----------|---|-----|-----|----|----------------|
| 273 | 18 | 19 | 111 4 5 | b | 40- | 15+ | 5 | O |
| 275 | 19 | 20 | 111 4 5 | b | 30+ | 10+ | 5 | O |
| 277 | 20 | 21 | 111 4 5 | b | 20+ | 10+ | 3 | O |
| 279 | 21 | 23 | 111 4 5 | b | 20+ | 10+ | 3 | O |
| 281 | 23 | 24 | 111 4 5 | b | 20- | 10- | 3 | O |
| 283 | 24 | 25 | 111 4 5 | b | 20- | 10+ | 3 | |
| 285 | 25 | 26 | 111 4 5 | b | 20- | 10+ | 3 | O |
| 287 | 26 | 27 | 111 4 5 | b | 10+ | 10- | 3 | |
| 289 | 27 | 28 | 111 4 5 | b | 10+ | 10- | 3 | Q |
| 291 | 28 | 30 | 111 4 5 | b | 15+ | 10- | 2 | R |
| Dc | | | | | | | | |
| 293 | 30 | 1 | 111 4 5 | b | 20+ | 10- | 0 | S |
| Dc | | | | | | | | |
| 295 | 1 | 2 | 333 4 5 | b | 20+ | 10+ | 5+ | Zero too wide. |
| 297 | 2 | 3 | 333 4 10 | b | 15+ | 10- | 5- | Good record. |
| 299 | 3 | 4 | 333 4 10 | b | 20- | 10- | 5 | T |
| 301 | 4 | 5 | 333 4 10 | b | 20- | 10- | 5 | |
| 303 | 5 | 7 | 333 4 10 | b | 20+ | 10+ | 4 | U |
| 305 | 7 | 8 | 333 4 10 | b | 20- | 10- | 3 | |
| 308 | 8 | 9 | 333 4 10 | b | 20- | 10- | 3 | V |
| 309 | 8 | 9 | 111 4 10 | b | 20- | 10- | 3 | V |
| 311 | 9 | 10 | 333 4 10 | b | 15+ | 10- | 3 | V |

DOMINION OBSERVATORY

| Rec | Fr | To | ABC-G-Db | S | Mx | Av | Mn | | Remarks |
|-----|----|----|----------|------|----|-----|-----|-----|-----------------|
| 312 | 9 | 10 | 111 | 4 10 | b | 15+ | 10- | 3 | V |
| 314 | 10 | 11 | 333 | 4 10 | b | 20+ | 10- | 3 | V |
| 315 | 10 | 11 | 111 | 4 10 | b | 20+ | 10- | 3 | V |
| 317 | 11 | 12 | 333 | 4 10 | b | 25+ | 10+ | 4 | |
| 320 | 12 | 14 | 333 | 4 10 | b | 25+ | 10+ | 4 | W |
| 323 | 14 | 15 | 333 | 4 10 | b | 40+ | 10- | 6 | X |
| 326 | 15 | 16 | 333 | 4 10 | b | 25+ | 10- | 4 | |
| 329 | 16 | 17 | 333 | 4 10 | b | 25+ | 10+ | 2 | Y |
| 332 | 17 | 18 | 333 | 4 10 | b | 40- | 20- | 10- | |
| 335 | 18 | 19 | 333 | 4 10 | b | 40+ | 20+ | 5+ | |
| 337 | 19 | 21 | 222 | 4 10 | d | 20+ | 10+ | 5+ | New schedule d. |
| 339 | 21 | 22 | 222 | 4 10 | d | 20+ | 10+ | 5+ | |
| 341 | 22 | 23 | 222 | 4 0 | d | 40- | 20- | 5+ | |
| | Dc | Dc | | | | | | | |
| 343 | 23 | 24 | 222 | 4 0 | d | 40+ | 25+ | 20- | Z |
| 345 | 24 | 28 | 222 | 4 0 | d | 20+ | 10+ | 5+ | A' |
| 348 | 28 | 29 | 222 | 4 0 | b | 20- | 5+ | 0 | B', C' |
| 349 | 28 | 29 | 333 | 4 2 | b | 25+ | 10- | 2 | B', C' |
| 350 | 28 | 29 | 111 | 4 5 | b | 20+ | 10+ | 3 | B', C' |
| 351 | 29 | 30 | 222 | 4 0 | b | 20- | 10- | 5 | D' |
| 352 | 29 | 30 | 333 | 4 7 | b | 20+ | 10+ | 5+ | D' |
| 353 | 29 | 30 | 111 | 4 7 | b | 20+ | 10+ | 5+ | D' |

| Rec | Fr | To | ABC-G-Db | S | Mx | Av | Mn | Remarks |
|-----|----|----|----------|-----|----|-----|--------|---------|
| 354 | 30 | 31 | 222 | 4 0 | b | 30+ | 10+ 5+ | D' |
| 355 | 30 | 31 | 333 | 4 7 | b | 30+ | 10+ 5+ | D' |
| 356 | 30 | 31 | 111 | 4 7 | b | 30+ | 10+ 5+ | D' |
| | | | | Ja | | | | |
| 357 | 31 | 2 | 222 | 4 0 | c | 20+ | 10+ 5+ | |

- A. Ran simultaneously with No. 195 in H4. See note M' for H4.
- B. First 'pull-out' test between H4 and H25; compare record No. 197 in H4. Deeper hole the more active.
- C. Activity fell off somewhat towards the end of the record, which ran over Sunday.
- D. Fairly continuous activity.
- E. Record caught fire but went out, leaving small burned hole.
- F. Feed seems irregular. Frequent small stoppages marked by burned holes, beginning on page 21115. Very bad on page 21119. Both styli give records that look much the same — a most unusual result. This is the first record from 222 since it was repaired after the fire of September 22. See Note H' for H4. It was fortunate that it did not catch fire again at this time.
- G. Paper caught fire and burned quite a section off one edge for nearly 2 min. on page 21603. The paper was feeding crookedly at the time. It came back to normal after about 40 min. Burned off at about 3:50 p.m. October 18, and the record stopped. During the last hour the paper slipped badly, remaining stationary, hence the burn-off. Did not catch fire, however.
- H. Most remarkable change in H25 since October 19.
- I. Paper ran crookedly during much of record. No fire. Voltage high on styli.
- J. Styli have too much friction with paper. Does not prevent most of the recording, but makes record very irregular, as stylus does not return to zero after each throw.
- K. May be small burst registered at 6:57 p.m., November 3. Slight trace on 24613A and well recorded on 24713A.
- L. Record began to run crookedly on page 24809. The edge was burned off the record for nearly 7 min. on page 24810. The record came back to position and no fire resulted.
- M. The stylus friction is much too great.
- N. Looks like a small burst at 6:57 p.m., November 4. In view of note K above, the record may be instrumental. It appears also on 24912, which seems to show that the disturbance is mechanical, but it may be seismic. If not, cause is not known. See also 25813A.
- O. Many electrical disturbances, lasting some minutes at a time, causing slight 25-cycle oscillation and a widening of the zero; cause is instrumental.

- P. Well-recorded burst lasting about 4 min. on page 26903 . Less well registered on 26803 for H28.
- Q. Severe oscillations resembling bursts on page 28919 for H25. They do not appear on corresponding pages of record 288 for H28, the latter being the newly adjusted 222 set.
- R. Burst felt by E.A.H. at 6:22 a.m., November 30. See page 29144A for H25 and compare 29043B for H28.
- S. Burst at 4:12 p.m., November 30 (see page 29306B); compare 29206B for H28.
- T. Some good records of ore-pass noise during the listening period.
- U. A series of bursts registered, beginning at 6 p.m., December 6; becoming quite violent at 6:12 p.m. (page 30337B); compare page 30230B on H28.
- V. Recorders 333 and 111 ran on an input divider, giving two records from the same hole.
- W. Activity falls off considerably towards the end of the record, to Av. 5- s.p.m.
- X. Maximum activity falls off very rapidly.
- Y. Activity becomes greater in second half of record, reaching Max. 30+, Av. 20+ Min. 10-.
- Z. Activity reported was on first period of record. The activity fell off to about Max. 20+, Av. 10+, Min. 5+.
- A'. Activity fell off to about Av. 5+ by the end of the record.
- B'. H25G4 was run through a voltage divider onto 111, 222, and 333. The results were far from satisfactory as regards equivalent recording.
- C'. Heavy burst at 6:06 p.m., December 28, recorded on all three sets.
- D'. Simultaneous recordings on 111, 222, and 333, from H25G4. Adjustment of sensitivity much better.

H26

| Rec | Fr | To | ABC-G-Db | S | Mx | Av | Mn | Remarks |
|-------|----|----|----------|------|-------|-----|----|---------|
| Oc Oc | | | | | | | | |
| 236 | 28 | 28 | 333 | 1 0 | a 3 | 1- | 0 | A |
| 240 | 30 | 31 | 333 | 1 0 | B 3 | 1- | 0 | B |
| Dc Dc | | | | | | | | |
| 336 | 18 | 19 | 111 | 1 10 | c 5 | 3 | 1 | |
| 338 | 19 | 21 | 333 | 1 10 | c - | - | - | C |
| 342 | 22 | 23 | 333 | 1 10 | c 20- | 10- | 5- | D |
| 344 | 23 | 24 | 333 | 1 10 | c 10- | 5- | 0 | |

| Rec | Fr | To | ABC-G-Db | S | Mx | Av | Mn | Remarks |
|-----|----|----|----------|---|-----|----|----|---------|
| 346 | 24 | 28 | 333 1 10 | c | 10- | 5- | 0 | E |
| Ja | | | | | | | | |
| 358 | 31 | 2 | 333 1 7 | c | - | - | - | F |

- A. Recorder all in good order, as blasting is well recorded. But in this 30' hole in 4201W-9 the activity has fallen almost to zero. For previous recording in this region see tabulation for H19.
- B. Last hour (6-7 a.m., October 31) of this record was run: 111G6H28.
- C. Entire record lost owing to ineffective contacts on the time switch.
- D. Considerable time lost owing to ineffective contacts on the time switch.
- E. Greatly increased activity towards the end of the record, up to Av. 50+. May be instrumental but does not appear to be so.
- F. Time-switch contacts very poor. Continual oscillations during the H26 part of the record.

H27

| Rec | Fr | To | ABC-G-Db | S | Mx | Av | Mn | Remarks |
|-------|----|----|----------|---|-----|----|----|---------|
| Dc Dc | | | | | | | | |
| 327 | 15 | 16 | 111 6 10 | b | A | A | A | A |
| 347 | 24 | 28 | 111 6 10 | b | 10- | 2- | 0 | B |

- A. Record very active: Av. 25+, but this may be instrumental, as the connecting cable is very long. If not, H27 must be very active. The activity increased slowly to 4 a.m., December 16, when it became quite pronounced as noted above, and so continued.
- B. Voltage too high on styli.

H28

| Rec | Fr | To | ABC-G-Db | S | Mx | Av | Mn | Remarks |
|-------|----|----|----------|---|----|----|----|---------|
| Oc Oc | | | | | | | | |
| 238 | 29 | 30 | 333 6 0 | b | 1 | 0+ | 0 | A |
| 240 | 30 | 31 | 333 6 0 | b | 6 | 3 | 1 | B |

DOMINION OBSERVATORY

| Rec | Fr | To | ABC-G-Db | S | Mx | Av | Mn | Remarks | | |
|-----|----|----|----------|---|----|----|-----|---------|---|---|
| | | | Nv | | | | | | | |
| 243 | 31 | 2 | 111 | 2 | 5 | b | 20- | 10+ | 2 | |
| | | | Nv | | | | | | | |
| 244 | 2 | 3 | 333 | 2 | 0 | b | 10+ | 5+ | 2 | C |
| 246 | 3 | 4 | 333 | 2 | 0 | b | 5+ | 2+ | 0 | D |
| 249 | 4 | 5 | 111 | 2 | 5 | b | 5+ | 2+ | 0 | |
| 251 | 5 | 6 | 333 | 2 | 0 | b | 20- | 10- | 2 | D |
| 252 | 6 | 7 | 333 | 2 | 0 | b | 5+ | 1+ | 0 | |
| 254 | 7 | 9 | 333 | 2 | 0 | b | 15+ | 5+ | 0 | |
| 256 | 9 | 10 | 333 | 2 | 0 | b | 10- | 5+ | 1 | |
| 258 | 10 | 11 | 333 | 2 | 0 | b | 10- | 5+ | 1 | |
| 260 | 11 | 12 | 333 | 2 | 0 | b | 10- | 2 | 0 | E |
| 262 | 12 | 13 | 333 | 2 | 0 | b | 10+ | 10- | 3 | |
| 264 | 13 | 14 | 333 | 2 | 0 | b | 20- | 10+ | 4 | |
| 266 | 14 | 16 | 333 | 2 | 0 | b | 20- | 10- | 3 | |
| 268 | 16 | 17 | 333 | 2 | 0 | b | 15+ | 5+ | 3 | F |
| 270 | 17 | 18 | 333 | 2 | 0 | b | 15- | 10- | 3 | E |
| 272 | 18 | 19 | 333 | 2 | 0 | b | 20- | 10+ | 3 | E |
| 274 | 19 | 20 | 333 | 2 | 0 | b | 10+ | 10- | 3 | G |
| 276 | 20 | 21 | 333 | 2 | 0 | b | 20- | 10+ | 3 | H |
| 278 | 21 | 23 | 333 | 2 | 0 | b | 20- | 10+ | 3 | |

| Rec | Fr | To | ABC-G-Db | S | Mx | Av | Mn | Remarks |
|-------|----|----|----------|-----|----|-----|-----|---------|
| 280 | 23 | 24 | 333 | 2 0 | b | 20+ | 10+ | 4 I |
| 282 | 24 | 25 | 222 | 2 5 | b | 5 | 2+ | 0 J |
| 284 | 25 | 26 | 222 | 2 5 | b | 5+ | 2+ | 0 |
| 286 | 26 | 27 | 222 | 2 5 | b | 5+ | 2+ | 0 |
| 288 | 27 | 28 | 222 | 2 5 | b | 4+ | 2+ | 0 |
| 290 | 28 | 30 | 222 | 2 5 | b | 5+ | 2- | 0 K |
| Dc | | | | | | | | |
| 292 | 30 | 1 | 222 | 2 5 | b | 10- | 3+ | 0 L |
| Dc | | | | | | | | |
| 294 | 1 | 2 | 222 | 2 5 | b | 5+ | 2+ | 0 |
| 296 | 2 | 3 | 222 | 2 0 | b | 5+ | 2+ | 0 |
| 298 | 3 | 4 | 222 | 2 0 | b | 10- | 5 | 1 |
| 300 | 4 | 5 | 222 | 2 0 | b | 10+ | 5+ | 0 M |
| 302 | 5 | 7 | 222 | 2 0 | b | 5+ | 5- | 1 N |
| 304 | 7 | 8 | 222 | 2 0 | b | 10+ | 5- | 1 |
| 307 | 8 | 9 | 222 | 2 0 | b | 15+ | 5+ | 2 |
| 310 | 9 | 10 | 222 | 2 0 | b | 5+ | 3+ | 0 |
| Dc Dc | | | | | | | | |
| 313 | 10 | 11 | 222 | 2 0 | b | 15+ | 10- | 1 |
| 316 | 11 | 12 | 222 | 2 0 | b | 15+ | 10- | 1 |
| 319 | 12 | 14 | 222 | 2 0 | b | 15+ | 10- | 1 O |
| 322 | 14 | 15 | 222 | 2 0 | b | 15+ | 10- | 1 |

DOMINION OBSERVATORY

| Rec | Fr | To | ABC-G-Db | S | Mx | Av | Mn | Remarks | |
|-----|----|----|----------|---|----|----|-----|---------|----------------------|
| 325 | 15 | 16 | 222 | 2 | 0 | b | 10- | 5+ | 0 |
| 328 | 16 | 17 | 222 | 2 | 0 | b | 10+ | 5+ | 2 |
| 331 | 17 | 18 | 222 | 2 | 0 | b | 20+ | 10- | 2 O |
| 334 | 18 | 19 | 222 | 2 | 0 | b | 20+ | 10- | 2 |
| 337 | 19 | 21 | 222 | 2 | 0 | c | 20+ | 10- | 2 P; new schedule c. |
| 339 | 21 | 22 | 222 | 2 | 0 | c | 40- | 20+ | 15+ |
| 341 | 22 | 23 | 222 | 2 | 0 | c | 40- | 20+ | 15+ |
| 343 | 23 | 24 | 222 | 2 | 0 | c | 50+ | 40+ | 20+ Q |
| 345 | 24 | 28 | 222 | 2 | 0 | c | 30+ | 20+ | 10+ R |
| Ja | | | | | | | | | |
| 357 | 31 | 2 | 222 | 2 | 0 | d | 5+ | 2+ | 0 New schedule d. |

- A. This activity is plainly instrument trouble. 111H4G2 for the same period gives a normally active record (see No. 239 for H4). G6 was taken to surface and the crystal was found to have been destroyed by moisture.
- B. New crystal in G6. Works very well.
- C. A number of disturbances, lasting a minute, more or less, which are probably due to electrical disturbance, since some are so identified during the listening period, 6-7 a.m.
- D. Friction of styli on paper much too great.
- E. Too much voltage on the styli.
- F. Some bursts, lasting about 4 min., on page 26803. Very pronounced on page 26903 for H25.
- G. Record ran crookedly, pages 27407 to 27409. Caught fire on edge (page 27407) and burned off edge for nearly 5 min. but did not set fire to record. Record resumed position and no recording lost.
- H. Towards the end of the record many small offsets registered on the fast stylus. May have been instrumental.

- I. Activity falls off towards end of record.
- J. Note that this falling off of activity is not real. The set 222 has been substituted for 333.
- K. Burst felt by E.A.H. at 6:22 a.m., November 30. See page 29043B (H28) and compare 29144A (H25).
- L. Burst at 4:12 p.m., November 30, hardly registers on 29206B, but is very well marked on 29306B (H25). Is this due to lack of calibration or to the fact that H25 is the deeper hole?
- M. Activity falls off towards the end of the record.
- N. Fairly well-marked burst occurred at 6:12 p.m., December 6 (page 30230B); this was much better marked on 333 H25 G4 Db 10, on page 30337B.
- O. Record falls off considerably towards the last, giving Av. 5-.
- P. Some lost time owing to poor contacts on time switch.
- Q. Activity reported was for first period only. It fell off until at the end of the record it was down to Max. 20+, Av. 10+, Min. 5+.
- R. Activity fell off gradually to about Av. 5+ by the end of the 4-day record.

K-9 Sample Records of Particular Interest

(1) Figure 48:

On the left-hand side of this illustration are shown a series of records leading up to a rockburst at 11 a.m., July 25, and to a second burst at 6:31 p.m., July 31. The bracketed numbers refer to corresponding serial numbers on the sections of records shown. Sections 1 to 7 show the activity at H7 (4201W-9-S) at a series of intervals from July 22 to July 31.

The rockburst of July 25 occurred in 4301W-9, about 125 ft. below H7. It is to be noted that H7 was later found to be in a slab of loose and probably not in very good contact with the solid rock of the pillar; it was only a foot deep (see section K-6). Of the samples shown, the nearest preceding record is No. 4, taken at 3:30 a.m., some 7.5 hours before the burst. It cannot be said to show any warning. Moreover, the record from H8 (4201W-7-N) as given in section K-8 showed no activity whatever about the time of the severe burst of July 25. As noted in K-6, this is a good hole in solid rock, 3'6" deep; it is 125 ft. above the burst and 200 ft. east. H8 is in the north (foot) wall. Evidently some 230 ft., even through solid rock, is too far to expect the subaudible, relatively high-frequency snaps to be picked up by the recorders.

On the other hand, consider sections 5, 6, and 7; the last one, about 15 hr. before the burst of July 31 at 6:41 p.m., shows warning activity of about 75 s.p.m. The activity continued after the burst, as can be seen from the activity for H7, records 44 and 46, as reported in K-8.

The series of sample records shows, then, one case where warning was a failure, in spite of the reasons mentioned. The other case indicates a good measure of warning activity, well before the time of the burst.

No. 3 shows a small burst that occurred near the geophone and lasted about two minutes. It is a good example of the way such small bursts record. Bursts such as this do not record on the surface seismograph as a rule. If one is listening to them underground, they are quite striking while the earphones are in place but, these removed, there is not a sound in the empty mine.

On the opposite side of Figure 48 are shown some typical recordings. No. 8 shows a marked increase of activity after the lapse of seven hours. The left-hand side was made at 7 p.m., July 9, and the right at 3 a.m., July 10, when the recorder again went into service. Such increases are said to indicate critical conditions, but no burst occurred in this case.

In No. 9, the 15 offsets beginning to the right of centre are due to blasts that did not occur in the Lake Shore mine. They could barely be heard with the unaided ear. They are of longer duration than the snaps to the left, and have a full record on the upper (slow) stylus — an indication that they originated at a considerable distance.

No. 10 shows the type of record obtained if the line from the geophone to the recorders is open or partly open. At first this type of record (obtained from lines that were sometimes open and sometimes closed, giving short runs of wild recording) was thought to have been caused by rock slides in stopes near the pick-up geophones.

No. 11 is a record of 'static' caused by slight electrical impulses picked up by the geophone-to-recorder cable or due to electrolytic action at a poor joint or a broken strand in the cable. Note that all the static is on the lower (fast) stylus and that three small snaps are to be identified by small irregularities on the upper line. This 'static' can be eliminated by making sure that good cables are used, with proper joints and no broken strands, and with a good shield.

No. 13 shows the record obtained in 4201W-8, owing to the sliding of ore in the pass at the cross-cut 800 ft. or more away, when skipping ore in No. 4 shaft. The skip intervals are approximately 70 sec. Two small sections, some 20 min. apart, are here given to show the effect as the amount of ore in the pass diminishes. After about an hour it fades down to a slight irregularity on the lower (fast) stylus.

(2) Figure 49:

This shows the history of activity in 4201W-8, leading up to the holing through of a 16-ft. rill from 4301W-8 on September 5. Records 1 to 9 and 10a to 13a were all made on the same recording equipment at H4. The series 10b to 13b was made from a geophone in a 30-ft. DD hole (H21) close to H4.

Note that:

- (1) The series in H4 shows a definite growth up to the time of greatest stress, September 5.
- (2) The series in H21 shows a much more marked increase on September 4. It is unfortunate that H21 was not occupied prior to September 2.

It is concluded that a 30-ft. hole is much more informative than one six feet deep. In this case the hole (H4) is the best of all the twenty odd 6-ft. holes drilled for this study.

If then, a 30-ft. hole is more informative than a 6-ft., what could one expect from a 100-ft. hole? To answer this question, H21 was deepened on September 22 to 103 ft., and several 'pull-out' tests were made; these are shown in Figure 49.

- (3) Figures 50 and 51:

These show a series of records made to compare the recording in a 100-ft. hole with that in a good 6-ft. hole. The respective holes, H25 (formerly H21) and H4, are drilled side by side in 4201W-7, as shown in Figure 46.

A geophone (G2) in the 6-ft. hole (H4) was run without any resetting on Obert unit 222. Another (G4) was run throughout the test on Obert unit 111 in H25. The geophone in H25 was run for four minutes at a depth of 100 ft., then another four minutes at a depth of 94 ft., and so on, at depths successively 6 ft. less. The comparative records from the second of these pull-out tests are shown in this illustration. On each record a sensitivity test (T) is recorded as a result of tapping (generally five times) on a steel anchor bolt let into the south wall of recording station B in 4201W-6. The bolt is at a distance of 125 ft. to 150 ft. from the collars of the two holes (see Figure 47).

The tests (T) show up well on each pair of records, indicating that contact with the rock was good at each setting and that the bottom of the 100-ft. hole is more active than the bottom of the 6-ft. The questions therefore arise:

- (1) How deep would one need to go to get beyond the zone of compression?
- (2) How would the simultaneous recordings from a 30-ft. hole, say, compare with those from the 100-ft. hole?

To answer the second question, a 30-ft. DD hole (H28) was drilled close to H4 and H25. The comparison tests were made through a long series of records from H25 and H28. (see section K-8).

*

Report L

January-March, 1943

.

The main events of the first three months of 1943 were the heavy crush bursts of January 29 and March 31. The first completely wrecked the section of the west pillar where the instruments were in operation, destroying all the available geophones and burying one of the three Obert sets. The second burst was also in the west pillar, but higher up. It completed the devastation of the pillar but did not materially increase damage to the research program.

The compilation of data of section K-8 was given in full because it leads up to the burst of January 29. This rockburst is the outstanding case where the records seem to give a decided warning. For the same reason, full data from holes H29 and H31 are given, these being the two holes from which records were obtained right up to the time of the burst. The most interesting results of the entire program were obtained at this time.

L-1 Recording Program in January

Determination of the best locale for the investigation, elimination of instrument trouble, and initiation of a regular program were completed by the end of 1942, and the program as developed was carried through regularly in January.

Three sets of Obert recorders and seven geophones were available. The recorders were set as follows: one was placed in station C on 3801W-9, and recorded alternately, by means of a time switch, from geophones in H29 in 3801W-9 and H31 in 3908W-7, the cable for the latter reaching the upper level via the manway rising from the 3950-ft. level at section 6.3W; two others were placed in station B on 4201W-6; one of these alternately served H27 in 4001W-7 and H24 in 4301W-7, the cable for the former coming down through the manway rising from the 4200-ft. level at section 8W, and that for the latter going down the manway from the 4200-ft. level at section 5.8W. These positions are shown in Figure 62. The third Obert set alternately served H25 and H28 in 4201W-7. All holes were in the south, or hangingwall, and each was 30 ft. deep except H25, which was 103 ft.

The seventh geophone was placed in H26 in 4201W-9 and was arranged for listening only. Except for occasional time-switch trouble, the program ran without interruption through January to the time of a large burst that occurred on January 29.

L-2 The Bursts of January 29 and March 31

On January 29, at 2:12 a.m. Eastern War Time (E. S. T. plus 2 hrs.), a heavy crush burst occurred in the exact section under investigation. The levels from 3825 to 4325 inclusive were affected. The drifts were more or less completely closed westward from approximately the line of section 6.

The levels 3825 and 3950 (see Figures 54 and 55) were completely blocked: 3901W (see Figures 55 and 56) was badly shattered. Within a few days, however, it was possible to get through on the south drift 3908W. The timber was badly shattered in 4001W drift (Figure 57) and the drift was blocked for a short distance at the line of section 6, but was opened with little delay. The flatback over 4301W-7 collapsed completely, and some damage was done in the drift. In Figures 47, 58, and 62, a large number of rectangles appear on the elevations along the tops of the various drifts. These are the cement plugs to which reference was made in section B-3. The rockburst of January 29 dropped these plugs down into the drifts (Figure 54). They were much harder to deal with than rock, so much so that the west end of the 4201W drift was opened up by means of a by-pass drifted through the footwall around the closed section of 4201W.

The effects of the burst on the instrumental equipment were disastrous. As was reported in section K-3, the part of the west pillar under investigation had been specially wired with heavy BXL cable for geophone lines and style B wire for the testing tappers. Practically all this wiring was destroyed. Every geophone was lost. The Obert set on 3801W-9 was buried and was not recovered. The station on 4201W-6 was badly shaken up, but the instruments were not damaged. The program was left with two Obert sets, no geophones, and no cable.

As quickly as possible the station on 4201W-6 was put into shape again and a hole 52 ft. deep (H32) was drilled in the south wall just west of it. This was not drilled at right angles to the wall, but with a strong westward tendency, to bring the far end of it well inside the pillar some distance west of the blocked point in the drift. Recording began here on February 13.

Another doghouse was built on 3801W, at about section 6, immediately east of the point at which the drift was blocked. A hole (H33) was drilled in the south wall close to the blocked point of the drift and bearing strongly to the west, so as to get as far into the pillar as possible. This hole was 53 ft. deep.

One of the recovered Obert sets served on 4201W-6; the other was installed in 3801W-6. When 3908W was cleared, it was found that H31 was not damaged, and geophone No. 1 was recovered from it. The BXL cable down the manway from the 3825-ft. level to the 3950-ft. level was tested and found intact. Its drift sections were replaced and H31 was connected to the set in the new station on 3801W-6. Recording from H31 and H33 began on March 2; some time-switch trouble occurred, but was finally cleared on March 6.

The program from H31, H32, and H33 ran without interruption during the rest of March, with no great activity showing at any time, either on the recorders or during listening tests. Then on March 31, at 3.41 a.m. E.W.T., there occurred another crush burst that affected the levels 3200 to 3950 in the west pillar. The sections of 3801W and 3901W that had been cleared after the burst of January 29 were again completely blocked. No damage was sustained by the equipment on 4201W-6, but the station on 3801W-6 was badly shaken up, the entire set being thrown from the bench to the floor, but without damage. Holes 31 and 33 were lost, together with the geophones and cables.

After a survey of the damage, the company decided, owing to the scarcity of manpower, to abandon for the duration of the war the mining operations in the west pillar from 3325 to 4200 inclusive, except between 3950 and 4075. The seismic investigations in that part of the mine were discontinued, and steps were taken to locate on the east side.

L-3 Records of the Bursts of January 29 and March 31

These bursts were multiple, as shown by the Kirkland Lake seismograph records (Figures 52 and 53). The first and second sections (89 sec. apart) of the January burst were recorded in overlapping fashion on the Ottawa seismogram. The Kirkland Lake record shows that the second section was much the larger. Only the large first burst of March 31 was recorded at Ottawa. The phases are very sharply marked on the Ottawa record. The seismograms can both be used in a further study of elastic wave propagation but that for the March burst will be especially valuable. A comparison of these records with those given in Report H shows how well the phases are defined and how exactly they follow the time pattern of the earlier bursts.

L-4 Analysis of the Records

It was realized early in January that additional staff and more equipment would be needed to cope with the volume of records coming in.

An additional clerical assistant was therefore engaged, and an emergency wooden comparator was constructed by Gibbs, pending the design of a more permanent instrument. The latter was built in the Observatory machine shop, and is shown in the two lower plates of Figure 60. It provides a means of rapidly and conveniently handling the records, of analysing and tabulating the counts, and of noting the times and nature of coincidences between the records. It automatically reduces the time scale from record to 'comparator sheet' by a factor of 1/2. Adjustments are provided to care for parallax between the recording styli of a set and for synchronizing the records. Only 3 to 5 inches of record can be synchronized at any one time with an accuracy suitable for noting coincidences, since the slightly different rates of travel of the recording paper cause the records to get out of step after a few minutes on the comparator. Five inches only of each of three records are, therefore, exposed simultaneously on the machine. It was found necessary to compare longer sections to permit of annotating the records for time and synchronization marks. Accordingly, an

annotator was built at Ottawa (see top picture of Figure 60). This permits rapid and convenient handling of the records, and exposes 15 inches or more of each of the three records at once. These two machines have greatly assisted in the analysis of the records. Counting has been done with the aid of a Veeder tally and, when the record was very active, the use of a small hand magnifier.

The January-March counts were tabulated as shown in L-12. The number of comparator sheets used for the period was 1017. The data for January only are listed in the report, as those for February and March were too scanty to permit any deductions with regard to the burst of March 31, which probably originated on the 3325-ft. level, some 500 ft. away from the nearest geophone.

The section of the west pillar that burst on January 29 (3825 ft. to 4325 ft.) was covered as completely as possible by the equipment available. The records, made up into book form and paginated, together with the numbered comparator sheets, were indexed by the analysis. The whole forms the first basic reference obtained at Lake Shore. The magnitude of the burst was unique in a seismic survey of this kind, and it was considered desirable to have these data ready for further examination in the light of later experience. It was not planned to continue such an elaborate system indefinitely.

The data in section L-12 show that the counts varied from period to period (alternate half hours from 4-7 and 16-19 hrs.). These p.m. counts might be expected to be higher, as they occur soon after blasting, but this is not always the case, as appears in Figure 59 and as noted in section L-7. It seemed best to average the p.m. and a.m. counts separately and to plot the values obtained. (Figure 59). The elevation of the mine for the sections concerned is shown in Figure 58. The graph of Figure 59 is discussed in section L-7.

L-5 Shifting Pressures

It has long been known that pressures in the mine shift from point to point in the pillar, sometimes owing to the progress of mining operations, sometimes because of bursts, and sometimes from unknown causes. A well-recorded example of this is seen in the series of records shown in Figure 61.

On the 3825-ft. level, H29 (3801W-9) recorded on Obert set 111 in the doghouse on 3801W-6 for the first half of each of the hours 4-7 and 16-19. The same set recorded from H31 on 3908W-7 for the last half of these hours. There are, therefore, no simultaneous recordings from these two geophones but, except for the absence of coincidences, this does not greatly matter. Sections of the twelve records from H29 are set side by side with sections of the twelve records from H31, taken only half an hour later in each case. Each section shows 2 min. 40 sec. of record. The period covered was January 16-18. January 17 was Sunday, when no work was done in the mine.

For the part of the pillar being studied, blasting was over about an hour before the first section, shown in the upper left corner, and mining was resumed shortly after the last record section, shown in the lower right corner. It is clear that, during the period of a week-end, when no work was done in the mine, the pressure gradually passed from the vicinity of H29 to the vicinity of H31. Moreover, although these holes were only slightly over 250 ft. apart, the activity at one did not record at the other. This (or these) centres of activity burst 10 days later.

L-6 Salvoes and Bursts

On July 25, 1942, a burst occurred in 4201W-9. The only records prior to this burst (Figure 48) were obtained for a few days from H7 (sample 3 of that illustration was reported in section K-9 (1) as a small burst). These were noticed first during the period preceding the burst of July 25. After that burst no more were noticed until late in December, when both Hallick and the writer heard what, for want of a better name, were dubbed 'salvoes'. These increased in number during January: when they recorded they were exactly like sample 3 of Figure 48. In January they were very numerous in both the upper and lower levels of the section of pillar being investigated. They could never be heard except through the amplifiers. It seems certain that these disturbances are seismic.

At other times, a single sharp snap could be heard with the unaided ear, but the recorder, after registering the initial sharp offset, continued to record snaps for some time. These disturbances were spoken of as bursts, although, except for the initial snap, nothing could be heard with the unaided ear, no damage was done, and they did not register on the surface seismograph.

Both types of disturbance were extremely local. Sometimes there was a marked difference between the records of H25 and H28, which were side by side in 4201W-7, the former 103 ft. deep and the latter 30 ft. They often did not record full on a geophone in the level next to that on which they registered as a maximum. Sometimes, when occurring in the deep hole H25, they would register at H29 in 3801W-9, but not at H27 in 4001W-7, only one level away.

It was thought that the occurrence of these salvoes and small bursts in a section of pillar indicated over-all pressure conditions approaching a critical point. One explanation advanced for their recording on H29, but not on H27 or H24 at the same time as on H25, is as follows: as has been previously reported, slight disturbances do not readily traverse a discontinuity (fault, break, or vein); if the walls of the pillar are laminated, with the supports for the deep-lying arch resting on the heavy pillars above 3700 and below 4325, then a disturbance originating in this deep-lying arch, which is penetrated by the deep hole H25, would not readily break through to the inner laminations to record on H27 (4001W-7). There were other evidences of this segregation of disturbances into arches.

L-7 The Graph of Record Counts for January 1943

The points for this graph were obtained from the record analyses by taking separately the values for large, medium, small, and total snaps for all p.m. and all a.m. observation periods each day. As plotted, the upper line shows the totals, the next the small, the next the medium, and the bottom the large snaps. The first ordinate after the date line shows the a.m. average, the second the p.m. average. Any question arising as to irregularities or breaks in the graph, not explained in the text following, can be answered by reference to section L-12.

H29 was very close to a working stope, but no other hole in service was nearer than 50 ft. This is especially interesting when the relative counts for p.m. and a.m. times each day are considered. On the 3825-ft. level, the p.m. counts (right after blasting, which occurs from 2^h to 3^h p.m. for these levels) are higher as a rule than the a.m. counts for the same day. All the high peaks are p.m. But on the 3950-ft. level (H31) the reverse is the case. All a.m. peaks are higher than those for the corresponding p.m. times.

It is likely that the counts on H29 are unduly affected by mining operations, as this hole was less than 25 ft. from a working stope that was close to breaking through to the 3825-ft. level from below.

It is interesting to trace a curve through the a.m. points and another through the p.m. points for H31. Each rises towards the date of the burst (January 29). On the other hand, those for H29 consistently flatten out towards that date.

Neither the large counts (lowest of the graph lines) nor the medium ones are very informative. The small are the best of the three, but there seems no valid reason, in the light of these graphs, for counting anything but the totals. The large and medium snaps should be noted for coincidences, but to count them separately seems a waste of time. Note the importance of recording small snaps.

It is evident that a count of 100 snaps per minute indicates a dangerous condition; but, in this all-too-short set of data, there are three peaks of nearly or greater than 100 without a burst. It is also to be regretted that the record for H29 and H31 for January 28-29 was lost with the recorder and cannot now be recovered.

The sharpness of the peaks is remarkable. If pressures build up and fall at this rate, it is evidently necessary to record 24 hours a day, or at least for short periods at close intervals for a full day, so that the records do not stop 8-10 hours before a burst.

The fact that the peaks for H29 do not coincide with those for H31, though the holes are only about 250 ft. apart, shows clearly that critical pressure is quite local and that the record reflects conditions within only a short distance, probably 50-100 ft., from the geophone. All seven geophones were in service and were distributed as evenly as possible over

the suspect section of the pillar. It was fortunate that the earlier attempts to obtain crystals and transformers had been made, for these arrived only just in time to permit the construction of new geophones after all those on hand had been lost in the burst.

The 100-ft. hole (H25) is not much more informative than the adjacent 30-ft. hole (H28). It is most unfortunate that, at the time when the comparison would have been most valuable, January 15-18, no records were obtained from H28, owing to the fact that the time-switch on 3801W-9 was giving trouble.

From a consideration of the Kirkland Lake record (Figure 52) and the graphs of Figure 59, it seems evident that the first (smaller) burst of January 29 occurred on the 3950 or the 3825-ft. level, or both, and that this initial burst allowed pressure to fall on 4200, raising it above the critical point and resulting in the general burst. During the fall of 1942, the conditions on 4200 had several times been considered critical, while the upper levels (3825 and 3950) were quiet. When, in January, the upper levels became critical, the counts on the lower levels fell, owing, no doubt, to the temporary relief afforded by the pressure taking up on the higher levels.

Evidently, in an extensive pillar such as this, it is necessary to have long-term observations over as much of the pillar as possible. If pressure gradually passes from point A to appear at B, some distance above or below, the load is still poised with respect to A, and a burst at B will probably result in another at A.

L-8 Deductions and Recommendations

It becomes increasingly evident that critical pressures are very limited in extent, that they build up and decrease quite rapidly, and that geophones indicate the conditions as critical only when within about 50 ft. Moreover, long-term, wide-area observations must be made to learn what points lying within 500 ft. or so of a region at the time critical have been under severe pressure some weeks or months previously with no relief from a burst. Recording should evidently be done continuously or at frequent intervals throughout the 24 hours, so that the entire diurnal variation in activity may be known. Many holes must be used, serviced first by an intensive listening program to locate critical regions and then covered by a close network of geophones and recorders. The recorders must, as far as possible, be kept well in the fill, and it must be possible to instal them in any of the drifts under observation. Geophones are almost certain to be lost in a burst.

It was therefore recommended that:

- (a) At least 100 crystals and 50 transformers be ordered, and that the necessary casings should be made in preparation for a time when many geophones will be simultaneously required.
- (b) Holes 30 ft. deep be drilled as soon as possible at regular intervals of about 100 ft. in the hangingwall in each drift to be studied. This, at the moment, indicated the west pillar

on the 3200 level and in both drifts on the east side from the 4700 level up or down as far as critical conditons were suspected.

(c) One geophone be placed in the hole nearest the centre of the pillar on each drift to be studied, and left there for the use of the listening program, to give one control point in each drift at which irregularities due to a different placing of a portable geophone could receive some check. These geophones should be included in the regular underground testing program.

(d) A regular daily listening program be begun at once, using the light-weight portable outfit under construction. At least three levels should be completely covered every day. Three or four minutes listening at each hole would suffice for this reconnaissance survey. The readings should be tabulated and plotted each day.

(e) Two portable instrument boxes of wood be designed and built on surface. These should be designed to house the three units of an Obert set with all normal auxiliary equipment. They should be wired for lights and outlets and have an external socket into which the AC supply could be plugged. The boxes should have hinged covers, to give ready access to the recorders and provide a bench top for working.

(f) In each level to be studied, an observing site be selected well within the fill section and on the side of the pillar towards the cross-cut, preferably against the footwall. At each site, a pair of L-shaped supports made of pipe should be set, with one end of each in a hole in the wall and the other firmly placed on the floor of the drift. These would provide a support for the portable instrument box. Above each site, heavy new lagging or timbering should be placed to enable the operators to work without hats in front of the instruments. To each site an AC supply be wired, terminating in a plug for connecting to the instrument box.

(g) For the time being, the set-ups on 3200W, 4201W, and 4700E be the only ones to be operated regularly and that until better arrangements can be made the records be run every alternate 15 min. throughout the 24 hours if this can be done without injuring the recorders.

(h) As soon as the listening program discloses a critical region, the portable instrument box be taken at once to the drift concerned and at least two geophones be connected to record every alternate 15 min. for the 24 hours.

(i) Time switches be made to enable four geophones to record, two and two, for alternate 15 min. on each new Obert unit.

(j) Large-scale elevations of each drift on the east side, similar to the one made for the west pillar, be made for the use of the survey.

(k) For all recording, the counts should be restricted to totals only and the coincidences noted only in the large and small categories. All records should be carefully studied, counted, tabulated, plotted, and booked each day as received. Routine testing of all

equipment, including the control geophones, should be carried forward on a regular program.

(1) Some means be found for implementing recommendation of section K-5(p). It is obvious that the progress of mining has a distinct bearing on the building up and movements of critical pressures. Some simple arrangement should be made whereby the survey engineers can, as a matter of routine, note the mining that has gone on each day in the section under survey and plot the information on the record graphs.

L-9 Instrument Development

After a year's experience with subaudible vibration recording instruments at Lake Shore Mines, it seemed worth while to describe some of the work done in servicing and repairing these instruments and in manufacturing associated parts and apparatus.

Geophones were first constructed after the Obert pattern, using brass pipe for cases and brass for crystal mounting tables. Originally, a transformer was placed at the collar of each drill-hole used, to properly couple the high-impedance rochelle salt crystal into the low-impedance transmission line to the recorder. Later, small coupling transformers were installed within the geophone cases themselves. The cases were made originally with a packing gland, to pass shielded cable into the case and maintain a water-tight joint, but this system was abandoned later. An amphenol connector was mounted on the geophone case.

In the first geophones constructed, the rochelle salt crystal was mounted by wedging it with mica into a slot cut in a brass post. It was then firmly cemented in place with Duco cement. Later, instead of the mica wedges, a larger slot was cut in the support post, and a brass plate clamped against the crystal with small machine screws.

In a new type of mounting devised by Obert, a small steel plate was clamped across the end of the crystal, making a much simpler and more rugged support than any that had been used before; this mount was used in the geophones received in March 1943.

Originally, geophones were loaded into holes with an unwieldy, plumber's 'snake'. This is still used for deep holes, but for holes up to 30 ft. in depth a special set of loading poles was developed, made of 6-ft. lengths of 3/8-inch iron pipe, one of which, to be used next the geophone, has welded on a short length of one-inch pipe with a slot for the geophone cable. The sections are provided with a special coupling device by means of which a sufficient number may be coupled together to set the geophone at the desired depth. By pushing with the poles and pulling with the cable, the geophone may be adjusted until it is certain that contact with the floor of the hole is good.

It was evident early in the program that some means must be devised for turning the recorders on and off. Consequently, Telechron 'Organizer' clocks, used in controlling home radios in accordance with a pre-arranged schedule, were first tried. As they automatically

cleared themselves after a program was finished, changes had to be made in the internal construction in order that they would repeat, every twelve hours, whatever schedule had been set up. These clocks gave good service; their chief drawback was that the operation of the switch might vary by about a minute, more or less, at different settings, making it difficult to correlate records made at different locations in the mine. (It was later found that the larger snaps, recorded by all sets, made it possible to correlate even widely separated recording outfits.)

To enable recorders to cover more than a single hole, it was decided to make up switches that would, at regular intervals, connect to an amplifier either one of two geophones. Double-pole, double-throw switches of a toggle type, actuated by a synchronous clock mechanism, were constructed. Telechron clocks were again used, the face and hands being removed and a special spindle driven by the minute hand gear supporting a crank arm connected to the switch mechanism, which was thrown each half hour.

It was soon realized that some method of identifying which of the two geophones was connected at a given instant must be worked out. An extra pair of contacts was therefore placed on each switch so that, when one pair of contacts was closed, an auxiliary circuit caused an extra writing stylus to make a continuous line on the edge of the record, as long as that particular geophone was connected. These clock switches were not too satisfactory, owing to the fact that while the toggle action was fast, the clock motion was slow, resulting in an interval during which the contact pressure was lightened, allowing stray disturbing voltages to be impressed on the connecting cables. Plans were therefore made to change to microswitches, which had been in short supply.

Some means of easily changing from geophone to geophone while listening to the rock noises was needed. To do this, a switch-in device (LSM-13) was constructed. It consisted of two double-contact switches arranged to connect any one of six geophones to either of the two amplifier channels that comprised LSM-11. This made it possible to listen to a geophone with one ear while the other listened to one some distance away. In this manner, holes could be quickly compared for activity and simultaneity.

Simultaneous comparison of two recorders was achieved by a device that splits the signal from one geophone and supplies it to the input circuits of the two amplifiers to be compared; this amounts to connecting the input transformers in parallel. The loss of sensitivity occasioned by this parallel connection proved negligible. While originally intended for testing with a geophone under actual recording conditions, the input comparator proved invaluable in laboratory testing. A test impulse oscillator is connected through the input comparator to the recorder under test and at the same time to a recorder known to be properly adjusted. Examination of the two records obtained gives a check, not only of the amplifier and recorder, but also of the validity of the output of the test impulse oscillator while the test is being made.

High-grade vacuum-tube amplifiers for listening to subaudible vibrations in rock must have high amplification and stability, and must be readily portable: low battery drain is also desirable. It was decided, after a number of experiments, to construct an amplifier with four 6.3-volt tubes that would utilize the regular storage batteries used for miners' lamps. Such an instrument would weigh about 10 1/2 pounds, and could be readily carried in a haversack. All the operator would have to do would be to insert a geophone in each hole as he reached it.

A program such as that being carried on at Lake Shore depends largely on the comparison of results recorded by instruments of the same type located at various points. It was therefore essential to have some means whereby it could be ensured that the various instruments were identical in their responses, and would remain so over long periods. This was achieved by means of a test impulse oscillator built from a design furnished by Dr. Obert, which was designated LSM-14. It operates by applying a pulse of fixed length and amplitude to the input terminals of a recorder amplifier by depressing a switch. Once the instrument is adjusted to give the most suitable pulse length and amplitude, with a fixed frequency, all subsequent standardizing tests are made with the same settings of the controls. As the cycle is controlled by the circuit characteristics, once the switch is depressed there is no question of the personal equation affecting the test. The instrument is easily portable, and the various recording instruments can therefore be readily checked in situ.

The test impulse oscillator, while affording an excellent means of checking the amplifier-recorder combination, gives no check of the geophone itself. As the geophone is the source of the electrical impulses that are the basis of the recorded observations, it was of first importance that its responses should be uniform. A shaking table, vibrating in response to energy supplied by a master oscillator, was therefore built. A geophone placed on this table drives its own voltage amplifier, to which a vacuum tube voltmeter is attached; this provides a means of comparing the results of changes of frequency of amplitude.

The method described in the preceding paragraph is, of course, impracticable underground. It was therefore decided to investigate the possibility of devising an instrument for underground use that would make use of the fact that if a capacity is connected to one pair of terminals of an ideal transformer, the other pair exhibits a capacitive reactance that is a function of the original capacity and the impedance ratio of the transformer. Tests were therefore made of the capacitive reactance of the low-impedance side of the geophone transformers, the high-impedance sides being connected to the Rochelle salt crystals. By this means it was determined that geophones in good condition gave capacitance values of 1.4 to 3.4 microfarads, whereas defective ones gave values in excess of 70 microfarads. The measurement of capacity of each geophone and connecting cable is measured immediately after installation, and entered along with data determined from the laboratory test. Capacity measurements are then made weekly at the same time as the routine tests of recorders, and will indicate gradual or complete failure of the crystal.

For an over-all test of each geophone and its amplifier-recorder, a set of tappers was installed in the vicinity of each installation. These consist of a steel pendulum that may be swung against the end of a steel rod set in the rock by means of a motor-driven cam. While this test will not give comparable records, in view of the different ground conditions, the records for a given installation should be identical unless some change has occurred in the system.

Shortly after the recorders were installed, trouble was experienced with the writer coils, which burnt out in a very short time. It was found that the moist, acid mine air caused electrolytic corrosion, and installation of a 50-watt electric lamp in the recorder boxes remedied the situation. Later, coils were wound on bakelite forms and impregnated with moisture-proof wax, as an added precaution.

Trouble was also experienced with charring, and occasionally burning, of the paper rolls. This was finally traced to misalignment, apparently caused by rough handling during shipping, which resulted in faulty contact with the platen. As the recording in this type of machine is electrical, the poor contact caused arcing at the recorder stylus. All machines were adjusted to give perfect alignment, and no further difficulty from this cause was experienced.

As underground line voltage seldom exceeds 90 volts, which is not satisfactory for operating electronic instruments, transformers were installed at each recording station to raise the voltage to approximately 110 volts, at which point fluctuations could be remedied by the automatic regulation device incorporated in the amplifier.

At some high-gain adjustments, the writer styli were found to oscillate wildly without any impulse from the geophone. The cause was discovered to be small changes of current occurring at the writing point, causing large voltage changes at the point where the current was taken from the power supply. Filter sections between this point and the plate circuit of the first high-gain amplifier tube eliminated most of the trouble, which was finally cured by applying a by-pass condenser directly between the supply point and ground, across the current-limiting resistors and writer point; by this means, also, much higher amplifications were made possible.

L-10 Test Holes Used, January to March, 1943

The only test holes used for recording purposes in the rockburst research program during the period January-March 1943 were: Nos. 24, 25, 27, 28, 29, 31, 32, and 33. These are located on the plan and elevation diagrams of Figure 62. Plans and elevations have each a vertical scale indicated by the 125-ft. difference between the levels. The section lines are 100 ft. apart. In the projection of the plans, the oblique lines run down and to the left (south) and up and to the right (north), the scale division, both east-west and north-south, being 50 ft.

L-11 Dates of Recording from Test Holes

Records from the holes noted in the preceding section were made on the dates indicated in the tabulation below. The solid vertical rulings show week-ends.

January

| 1 | 2 | 3 | 4 | 5 | 6 | 7 | 8 | 9 | 10 | 11 | 12 | 13 | 14 | 15 | 16 | 17 | 18 | 19 | 20 | 21 | 22 | 23 | 24 | 25 | 26 | 27 | 28 | 29 | 30 | 31 |
|----|----|----|----|----|----|----|----|----|----|----|----|----|----|----|----|----|----|----|----|----|----|----|----|----|----|----|----|----|----|----|
| 24 | 24 | 24 | 24 | 24 | 24 | 24 | 24 | 24 | 24 | 24 | 24 | 24 | 24 | 24 | 24 | 24 | 24 | 24 | 24 | 24 | 24 | 24 | 24 | 24 | 24 | 24 | 24 | 24 | 24 | 24 |
| 25 | 25 | 25 | 25 | 25 | 25 | 25 | 25 | 25 | 25 | 25 | 25 | 25 | 25 | 25 | 25 | 25 | 25 | 25 | 25 | 25 | 25 | 25 | 25 | 25 | 25 | 25 | 25 | 25 | 25 | 25 |
| 27 | 27 | 27 | 27 | 27 | 27 | 27 | 27 | 27 | 27 | 27 | 27 | 27 | 27 | 27 | 27 | 27 | 27 | 27 | 27 | 27 | 27 | 27 | 27 | 27 | 27 | 27 | 27 | 27 | 27 | 27 |
| 28 | 28 | 28 | 28 | 28 | 28 | 28 | 28 | 28 | 28 | 28 | 28 | 28 | 28 | 28 | 28 | 28 | 28 | 28 | 28 | 28 | 28 | 28 | 28 | 28 | 28 | 28 | 28 | 28 | 28 | 28 |
| 29 | 29 | 29 | 29 | 29 | 29 | 29 | 29 | 29 | 29 | 29 | 29 | 29 | 29 | 29 | 29 | 29 | 29 | 29 | 29 | 29 | 29 | 29 | 29 | 29 | 29 | 29 | 29 | 29 | 29 | 29 |
| | | | | | | | | | 31 | 31 | 31 | 31 | 31 | 31 | 31 | 31 | 31 | 31 | 31 | 31 | 31 | 31 | 31 | 31 | 31 | 31 | 31 | 31 | 31 | |

February

| 1 | 2 | 3 | 4 | 5 | 6 | 7 | 8 | 9 | 10 | 11 | 12 | 13 | 14 | 15 | 16 | 17 | 18 | 19 | 20 | 21 | 22 | 23 | 24 | 25 | 26 | 27 | 28 |
|---|---|---|---|---|---|---|---|---|----|----|----|----|----|----|----|----|----|----|----|----|----|----|----|----|----|----|----|
| | | | | | | | | | | | | 32 | 32 | 32 | 32 | 32 | 32 | 32 | 32 | 32 | 32 | 32 | 32 | 32 | 32 | 32 | 32 |

March

| 1 | 2 | 3 | 4 | 5 | 6 | 7 | 8 | 9 | 10 | 11 | 12 | 13 | 14 | 15 | 16 | 17 | 18 | 19 | 20 | 21 | 22 | 23 | 24 | 25 | 26 | 27 | 28 | 29 | 30 | 31 |
|----|----|----|----|----|----|----|----|----|----|----|----|----|----|----|----|----|----|----|----|----|----|----|----|----|----|----|----|----|----|----|
| 32 | 32 | 32 | 32 | 32 | 32 | 32 | 32 | 32 | 32 | 32 | 32 | 32 | 32 | 32 | 32 | 32 | 32 | 32 | 32 | 32 | 32 | 32 | 32 | 32 | 32 | 32 | 32 | 32 | 32 | |
| 33 | 33 | 33 | 33 | 33 | 33 | 33 | 33 | 33 | 33 | 33 | 33 | 33 | 33 | 33 | 33 | 33 | 33 | 33 | 33 | 33 | 33 | 33 | 33 | 33 | 33 | 33 | 33 | 33 | 33 | |

Drillers' reports for holes from H1 to H30 inclusive were given in section K-6. The reports for H31, H32, and H33, used in the above program, will appear in section M-2. The limited recording of February and March was due to the loss of geophones in the burst of January 29.

L-12 Record Analysis for H29 and H31, January-March 1943

It seems sufficient in this publication to give the analysis for H29 and H31 only, as these were the only holes from which informative data were obtained. They operated until January 28 only, the recorder, together with its records for January 29, being lost in the rockburst.

In the following tabulation, the successive headings have the following signification:

| | | |
|----------|---|--|
| Rec | = | record number. |
| Fr | = | from (date of). |
| To | = | to (date of.) |
| Epoch | = | the instant, in Eastern War Time, beginning at midnight on the 24-hr. system, about which the averaging interval was taken. In the case of a two-day record, an underline indicates the interval as being in the second part of the record. As the records are changed about 7:30 a.m., the first instant given on any day is in p.m. time. |
| AP | = | the averaging period, i.e. the number of minutes over which the counts were made and averaged. |
| L,M,S,T, | = | the average s.p.m. of, respectively, the large, medium and small snaps; and the total value of all three categories added, only the counts for the fast stylus having been considered. |
| N | = | the serial number of the comparator sheet (inserted in the original report for the use of the operators and clerical staff). |
| Con-Rec | = | concurrent records read for coincidences with the record being tabulated. |
| Co'ce | = | coincidences between records. The first entry shows the number of coincidences between the record being tabulated and the first concurrent record for the entire averaging period; the second shows the number of coincidences between the record being tabulated and the second concurrent record for the same period (unless the notes indicate otherwise at any point). |
| Notes | = | index letters for the series of notes immediately following the tabulation. |

Throughout the entire period covered by the analysis, the recorder used for both holes was 111, which was run at 7 Db. The geophone used in H29 was G5; that used in H31 being G1. The holes are, respectively, on the 3825 level and the 3950 level, as shown in Figure 61. The drillers' reports for the holes were given in section K-6.

DOMINION OBSERVATORY

| Rec | Fr | To | Epoch | AP | L | M | S | T | N | Con-Rec | Co'ce | Notes |
|-----|----|----|--------------|----|---|---|---|---|----|---------|-------|-------|
| | Ja | Ja | | | | | | | | | | |
| 362 | 2 | 4 | 16:20 | - | - | - | - | - | 1 | H26 H25 | - - | A |
| 362 | 2 | 4 | 16:48 | - | - | - | - | - | 2 | H24 H28 | - - | A |
| 362 | 2 | 4 | 18:22 | - | - | - | - | - | 3 | H26 H25 | - - | A |
| 362 | 2 | 4 | 18:48 | - | - | - | - | - | 4 | H24 H28 | - - | A |
| 362 | 2 | 4 | 4:20 | - | - | - | - | - | - | H26 H25 | - - | A |
| 362 | 2 | 4 | 4:52 | - | - | - | - | - | 5 | H24 H28 | - - | A |
| 362 | 2 | 4 | 6:22 | - | - | - | - | - | 6 | H26 H25 | - - | A |
| 362 | 2 | 4 | 6:48 | - | - | - | - | - | 7 | H24 H28 | - - | A |
| 362 | 2 | 4 | <u>16:20</u> | - | - | - | - | - | 8 | H26 H25 | - - | A |
| 362 | 2 | 4 | <u>16:46</u> | - | - | - | - | - | 9 | H24 H29 | - - | A |
| 362 | 2 | 4 | <u>18:18</u> | - | - | - | - | - | 10 | H26 H25 | - - | A |
| 362 | 2 | 4 | <u>18:48</u> | - | - | - | - | - | 11 | H24 H28 | - - | A |
| 362 | 2 | 4 | <u>4:17</u> | - | - | - | - | - | 12 | H26 H25 | - - | A |
| 362 | 2 | 4 | <u>4:47</u> | - | - | - | - | - | 13 | H24 H28 | - - | A |
| 362 | 2 | 4 | <u>6:20</u> | - | - | - | - | - | 14 | H26 H25 | - - | A |
| 362 | 2 | 4 | <u>6:48</u> | - | - | - | - | - | 15 | H24 H28 | - - | A |
| 365 | 4 | 5 | 16:18 | - | - | - | - | - | 16 | H27 H25 | - - | B |
| 365 | 4 | 5 | 16:48 | - | - | - | - | - | 17 | H24 H28 | - - | B |
| 365 | 4 | 5 | 18:18 | - | - | - | - | - | 18 | H27 H25 | - - | B |
| 365 | 4 | 5 | 18:46 | - | - | - | - | - | 19 | H24 H28 | - - | B |

| Rec | Fr | To | Epoch | AP | L | M | S | T | N | Con-Rec | Co'ce | Notes |
|-----|----|----|-------|----|-----|------|------|------|----|---------|-------|--------|
| 365 | 4 | 5 | 4:10 | - | - | - | - | - | 20 | H27 H25 | - - | B |
| 365 | 4 | 5 | 4:44 | - | - | - | - | - | 21 | H24 H28 | - - | B |
| 365 | 4 | 5 | 6:10 | - | - | - | - | - | 22 | H27 H25 | - - | B |
| 365 | 4 | 5 | 6:42 | - | - | - | - | - | 23 | H24 H28 | - - | B |
| 368 | 5 | 6 | 16:14 | 16 | 1.2 | 13.8 | 48.5 | 63.4 | 24 | H27 H25 | 1 1 | C |
| 368 | 5 | 6 | 16:46 | 16 | .6 | 4.5 | 19.4 | 24.5 | 25 | H24 H28 | 3 3 | C |
| 368 | 5 | 6 | 18:16 | 16 | .8 | 3.6 | 12.5 | 16.9 | 26 | H27 H25 | 5 5 | |
| 368 | 5 | 6 | 18:46 | 16 | .6 | 3.1 | 12.9 | 16.6 | 27 | H24 H28 | 2 2 | |
| 368 | 5 | 6 | 4:20 | 16 | .9 | 5.9 | 29.8 | 36.6 | 28 | H27 H25 | 5 5 | |
| 368 | 5 | 6 | 4:44 | 16 | .3 | 1.4 | 10.4 | 12.2 | 29 | H24 H28 | 8 8 | |
| 368 | 5 | 6 | 6:10 | 16 | 1.9 | 7.4 | 21.4 | 30.7 | 30 | H27 H25 | 10 10 | |
| 368 | 5 | 6 | 6:48 | 16 | .3 | 1.5 | 7.6 | 9.3 | 31 | H24 H28 | 4 4 | |
| 371 | 6 | 7 | 16:18 | 16 | 0.0 | .1 | 3.6 | 3.6 | 32 | H27 H25 | - - | D,E, |
| 371 | 6 | 7 | 16:46 | - | - | - | - | - | 33 | H24 H28 | - - | D,E,F, |
| 371 | 6 | 7 | 17:14 | 16 | 0.0 | 0.0 | 2.0 | 2.0 | 34 | H27 H25 | - - | D,E |
| 371 | 6 | 7 | 17:46 | 16 | 0.0 | 0.0 | 1.2 | 1.2 | 35 | H24 H28 | - - | D,E |
| 371 | 6 | 7 | 18:14 | 16 | 0.0 | 0.0 | 1.8 | 1.8 | 36 | H27 H25 | - - | D,E |
| 371 | 6 | 7 | 18:46 | 16 | 0.0 | .2 | 3.7 | 3.9 | 37 | H24 H28 | - - | D,E |
| 371 | 6 | 7 | 4:14 | 16 | .2 | 2.3 | 65.7 | 68.1 | 38 | H27 H25 | - - | D,E,G |
| 371 | 6 | 7 | 4:48 | 15 | .6 | 3.7 | 17.1 | 21.4 | 39 | H24 H28 | - - | D,E,H |
| 371 | 6 | 7 | 5:14 | 16 | 0.0 | 0.0 | .7 | .7 | 40 | H27 H25 | - - | D,E |
| 371 | 6 | 7 | 5:46 | 16 | 0.0 | 0.0 | .5 | .5 | 41 | H24 H28 | - - | D,E |

DOMINION OBSERVATORY

| Rec | Fr | To | Epoch | AP | L | M | S | T | N | Con-Rec | Co'ce | Notes |
|-----|----|----|-------|----|-----|------|------|-------|----|---------|-------|-------|
| 371 | 6 | 7 | 6:14 | 16 | 0.0 | 0.0 | .8 | .8 | 42 | H27 H29 | - - | D,E |
| 371 | 6 | 7 | 6:40 | 16 | 0.0 | 0.0 | .9 | .9 | 43 | H24 H28 | - - | D,E |
| 376 | 8 | 9 | 16:16 | 16 | .9 | 4.8 | 18.8 | 24.5 | 56 | H25 H28 | 7 7 | I |
| 376 | 8 | 9 | 16:44 | 16 | .6 | 3.2 | 12.8 | 16.6 | 57 | H24 H28 | 9 9 | |
| 376 | 8 | 9 | 17:12 | 16 | .5 | 2.8 | 9.9 | 13.2 | 58 | H25 H28 | 6 6 | |
| 376 | 8 | 9 | 17:40 | 16 | .6 | 1.9 | 10.9 | 13.4 | 59 | H24 H28 | 4 5 | |
| 376 | 8 | 9 | 18:10 | 16 | .4 | 2.7 | 10.2 | 13.3 | 60 | H25 H28 | 9 9 | |
| 376 | 8 | 9 | 18:40 | 16 | .7 | 2.3 | 9.9 | 12.8 | 61 | H24 H28 | 6 7 | |
| 376 | 8 | 9 | 4:16 | 16 | .8 | 1.9 | 10.0 | 12.7 | 62 | H25 H28 | 3 3 | |
| 376 | 8 | 9 | 4:46 | 16 | .9 | 1.5 | 10.9 | 13.4 | 63 | H24 H28 | 4 4 | |
| 376 | 8 | 9 | 5:12 | 16 | .8 | 2.7 | 9.6 | 13.1 | 64 | H25 H28 | 5 5 | |
| 376 | 8 | 9 | 5:44 | 16 | .7 | 1.7 | 10.1 | 12.4 | 65 | H24 H28 | 3 4 | |
| 376 | 8 | 9 | 6:18 | 16 | 1.4 | 1.4 | 10.0 | 12.8 | 66 | H25 H28 | 10 10 | |
| 376 | 8 | 9 | 6:48 | 16 | .5 | 1.7 | 8.5 | 10.7 | 67 | H24 H28 | 7 9 | J |
| 379 | 9 | 11 | 16:13 | 16 | 5.8 | 22.4 | 49.1 | 77.2 | 68 | H27 H25 | 16 - | K |
| 379 | 9 | 11 | 16:39 | 16 | 4.3 | 20.7 | 35.4 | 60.31 | 69 | H24 H28 | 3 - | K |
| 379 | 9 | 11 | 17:09 | 16 | 4.6 | 15.9 | 40.1 | 60.6 | 70 | H27 H25 | 8 - | K |
| 379 | 9 | 11 | 17:41 | 16 | 3.3 | 13.8 | 38.1 | 55.1 | 71 | H24 H28 | 10 - | K |
| 379 | 9 | 11 | 18:09 | 16 | 3.8 | 10.5 | 36.1 | 50.3 | 72 | H27 H25 | 9 - | K |
| 379 | 9 | 11 | 18:49 | 16 | 2.6 | 10.4 | 38.7 | 51.6 | 73 | H24 H28 | 6 - | K |
| 379 | 9 | 11 | 4:08 | 16 | 2.4 | 6.1 | 19.8 | 28.3 | 74 | H27 H25 | 4 - | K |

| Rec | Fr | To | Epoch | AP | L | M | S | T | N | Con-Rec | Co'ce | Notes |
|-----|----|----|--------------|----|-----|-----|------|------|----|---------|-------|-------|
| | Ja | Ja | | | | | | | | | | |
| 379 | 9 | 11 | 4:42 | 16 | 2.1 | 6.6 | 18.6 | 27.3 | 75 | H24 H28 | 6 - | K |
| 379 | 9 | 11 | 5:08 | 16 | 2.1 | 6.6 | 17.8 | 26.5 | 76 | H27 H25 | 12 - | K |
| 379 | 9 | 11 | 5:46 | 16 | 2.8 | 5.6 | 19.9 | 28.3 | 77 | H24 H28 | 5 - | K |
| 379 | 9 | 11 | 6:16 | 16 | 2.4 | 6.4 | 18.7 | 27.5 | 78 | H27 H25 | 6 - | K |
| 379 | 9 | 11 | 6:42 | 16 | 3.7 | 5.0 | 16.6 | 25.3 | 79 | H24 H28 | 9 - | K |
| 379 | 9 | 11 | <u>16:09</u> | 16 | 2.1 | 5.5 | 12.0 | 19.6 | 80 | H27 H25 | 1 - | K |
| 379 | 9 | 11 | <u>16:41</u> | 16 | 1.6 | 4.3 | 8.6 | 14.4 | 81 | H24 H28 | 1 - | K |
| 379 | 9 | 11 | <u>17:16</u> | 16 | 2.6 | 4.3 | 13.7 | 20.6 | 82 | H27 H25 | 6 - | K |
| 379 | 9 | 11 | <u>17:40</u> | 16 | 2.1 | 3.8 | 12.6 | 18.4 | 83 | H24 H28 | 3 - | K |
| 379 | 9 | 11 | <u>18:10</u> | 16 | 1.4 | 4.1 | 15.4 | 20.9 | 84 | H27 H25 | 11 - | K |
| 379 | 9 | 11 | <u>18:40</u> | 16 | 2.2 | 3.7 | 9.8 | 15.7 | 85 | H24 H28 | 6 - | K |
| 379 | 9 | 11 | <u>4:10</u> | 16 | 1.4 | 5.1 | 14.1 | 20.6 | 86 | H27 H25 | 2 - | K |
| 379 | 9 | 11 | <u>4:48</u> | 16 | 1.6 | 4.8 | 9.8 | 16.2 | 87 | H24 H28 | 7 - | K |
| 379 | 9 | 11 | <u>5:10</u> | 16 | .6 | 3.1 | 13.1 | 16.7 | 88 | H27 H25 | 5 - | K |
| 379 | 9 | 11 | <u>5:46</u> | 16 | 1.6 | 3.9 | 11.8 | 17.3 | 89 | H24 H28 | 2 - | K, L |
| 379 | 9 | 11 | <u>6:14</u> | 16 | 1.1 | 3.4 | 11.9 | 16.4 | 90 | H27 H25 | 3 - | K |
| 379 | 9 | 11 | <u>6:46</u> | 16 | 2.0 | 2.9 | 11.4 | 16.2 | 91 | H24 H28 | 1 - | K |
| 382 | 11 | 12 | 16:41 | 16 | 4.6 | 9.0 | 34.1 | 47.7 | 93 | H24 H28 | 5 5 | |
| 382 | 11 | 12 | 17:41 | 16 | 2.8 | 8.5 | 24.8 | 36.1 | 95 | H24 H28 | 3 3 | |
| 382 | 11 | 12 | 18:41 | 16 | 2.6 | 6.7 | 21.2 | 30.4 | 97 | H24 H28 | 5 5 | |

DOMINION OBSERVATORY

| Rec | Fr | To | Epoch | AP | L | M | S | T | N | Con-Rec | Co'ce | Notes |
|-----|----|----|-------|----|-----|------|------|------|--------|---------|-------|-------|
| 382 | 11 | 12 | 4:42 | 16 | 3.7 | 5.7 | 13.9 | 23.3 | 99 | H24 H28 | 6 8 | |
| 382 | 11 | 12 | 5:44 | 16 | 3.1 | 3.6 | 12.1 | 18.7 | 101 | H24 H28 | 10 11 | |
| 382 | 11 | 12 | 6:42 | - | - | - | - | - | 103 | H24 H28 | - - | M |
| 383 | 12 | 13 | 16:15 | 28 | 9.2 | 12.6 | 10.9 | 32.7 | 104-5 | H24 H28 | 11 13 | N,O |
| 383 | 12 | 13 | 16:45 | 29 | 6.1 | 7.2 | 14.4 | 27.6 | 106-7 | H27 H25 | 18 18 | P |
| 383 | 12 | 13 | 17:15 | 29 | 4.4 | 4.7 | 12.0 | 21.1 | 108-9 | H24 H28 | 7 8 | P |
| 383 | 12 | 13 | 17:45 | 29 | 4.1 | 5.9 | 10.8 | 20.8 | 110-11 | H27 H25 | 9 10 | P |
| 383 | 12 | 13 | 18:15 | 29 | 4.7 | 7.0 | 14.5 | 26.1 | 112-13 | H24 H28 | 4 4 | P,Q |
| 383 | 12 | 13 | 18:45 | - | - | - | - | - | 114-15 | H27 H25 | 2 4 | P,R |
| 383 | 12 | 13 | 4:15 | 28 | 3.2 | 4.6 | 11.6 | 19.4 | 116-17 | H24 H28 | 2 3 | S |
| 383 | 12 | 13 | 4:44 | 28 | 2.4 | 4.5 | 11.3 | 18.2 | 118-19 | H27 H25 | 1 1 | T |
| 383 | 12 | 13 | 5:16 | - | - | - | - | - | 120-21 | H24 H28 | 1 1 | U |
| 383 | 12 | 13 | 5:44 | - | - | - | - | - | 122-23 | H27 H25 | - - | U |
| 383 | 12 | 13 | 6:15 | - | - | - | - | - | 124-25 | H24 H28 | - - | U |
| 386 | 13 | 14 | 16:15 | 24 | 5.9 | 7.9 | 11.9 | 25.7 | 128-29 | H24 H28 | 3 4 | V |
| 386 | 13 | 14 | 17:17 | 24 | 5.1 | 8.6 | 11.3 | 25.1 | 132-33 | H24 H28 | 4 6 | V |
| 386 | 13 | 14 | 18:18 | 26 | 4.1 | 7.9 | 10.9 | 22.9 | 136-37 | H24 H28 | 9 10 | W |
| 386 | 13 | 14 | 4:12 | 10 | 2.0 | 23.0 | 33.7 | 58.7 | 140 | H24 H28 | 5 0 | V,X |
| 386 | 13 | 14 | 5:08 | 10 | 2.2 | 18.3 | 33.1 | 53.6 | 142 | H24 H28 | 0 0 | V |
| 386 | 13 | 14 | 6:16 | 10 | 2.6 | 16.9 | 26.3 | 45.8 | 144 | H24 H28 | 0 0 | V |
| 389 | 14 | 15 | 16:09 | 16 | 3.5 | 12.9 | 23.6 | 40.0 | 146 | H24 H28 | 3 5 | |
| 389 | 14 | 15 | 17:17 | 16 | 4.1 | 13.0 | 22.1 | 39.2 | 148 | H24 H28 | 4 4 | |

ROCKBURST RESEARCH 1938-45

157

| Rec | Fr. | To | Epoch | AP | L | M | S | T | N | Con-Rec | Co'ce | Notes |
|-----|-----|----|--------------|----|-----|------|-------|-------|-----|---------|-------|-------|
| 389 | 14 | 15 | 18:11 | 16 | 4.9 | 15.9 | 23.9 | 44.8 | 150 | H24 H28 | 5 5 | |
| 389 | 14 | 15 | 4:10 | 16 | 4.6 | 23.6 | 34.9 | 63.2 | 152 | H24 H28 | 4 4 | |
| 389 | 14 | 15 | 5:24 | 14 | 1.9 | 20.9 | 33.8 | 56.6 | 154 | H24 H28 | 4 4 | |
| 389 | 14 | 15 | 6:12 | 16 | 2.8 | 13.0 | 27.4 | 43.3 | 156 | H24 H28 | 5 5 | |
| 392 | 15 | 16 | 16:12 | 16 | 6.8 | 16.9 | 18.0 | 41.6 | 158 | H24 H25 | 6 7 | V |
| 392 | 15 | 16 | 17:12 | 16 | 4.3 | 10.3 | 17.0 | 31.6 | 160 | H24 H25 | 3 3 | |
| 392 | 15 | 16 | 18:18 | 16 | 6.1 | 12.6 | 19.4 | 38.1 | 162 | H24 H25 | 7 7 | Z |
| 392 | 15 | 16 | 4:12 | 16 | 3.1 | 10.1 | 26.4 | 39.6 | 164 | H24 H25 | 8 10 | A' |
| 392 | 15 | 16 | 5:18 | 16 | 2.5 | 9.6 | 16.4 | 28.4 | 166 | H24 H25 | 3 4 | |
| 392 | 15 | 16 | 6:12 | 16 | 2.1 | 7.6 | 14.5 | 24.2 | 168 | H24 H25 | 14 14 | |
| 395 | 16 | 18 | 16:12 | 2 | 8.0 | 65.0 | 100.0 | 173.0 | 170 | H24 H25 | 6 6 | B' |
| 395 | 16 | 18 | 17:11 | 16 | 4.8 | 26.9 | 38.7 | 70.4 | 172 | H24 H25 | 8 8 | |
| 395 | 16 | 18 | 18:17 | 16 | 3.9 | 15.1 | 31.8 | 50.7 | 174 | H24 H25 | 7 9 | |
| 395 | 16 | 18 | 4:18 | 16 | 3.4 | 7.8 | 21.3 | 32.4 | 176 | H24 H25 | 11 11 | |
| 395 | 16 | 18 | 5:12 | 16 | 2.8 | 8.3 | 22.4 | 33.5 | 178 | H24 H25 | 7 7 | |
| 395 | 16 | 18 | 6:20 | 16 | 2.4 | 6.6 | 21.3 | 30.2 | 180 | H24 H25 | 6 6 | |
| 395 | 16 | 18 | <u>16:25</u> | 16 | 1.9 | 4.8 | 13.9 | 20.6 | 182 | H24 H25 | 2 2 | |
| 395 | 16 | 18 | <u>17:16</u> | 16 | 1.8 | 6.3 | 15.8 | 23.8 | 184 | H24 H25 | 1 1 | |
| 395 | 16 | 18 | <u>18:18</u> | 16 | 2.1 | 6.9 | 18.4 | 27.4 | 186 | H24 H25 | 2 3 | |
| 395 | 16 | 18 | <u>4:14</u> | 16 | 1.4 | 4.8 | 17.1 | 23.3 | 188 | H24 H25 | 3 3 | |
| 395 | 16 | 18 | <u>5:12</u> | 16 | .9 | 6.4 | 15.3 | 22.7 | 190 | H24 H25 | 0 0 | |

DOMINION OBSERVATORY

| Rec Ja | Fr Ja | To Ja | Epoch | AP | L | M | S | T | N | Con-Rec | Co'ce | Notes |
|-----------|----------|----------|-------------|----|-----|------|------|-------|-----|---------|-------|-------|
| 395 | 16 | 18 | <u>6:14</u> | 16 | .8 | 4.3 | 20.0 | 25.1 | 192 | H24 H25 | 4 | 4 |
| 398 | 18 | 19 | 16:13 | 16 | 6.4 | 22.3 | 40.3 | 68.9 | 194 | H24 H28 | 3 | 3 C' |
| 398 | 18 | 19 | 17:19 | 16 | 4.0 | 10.6 | 28.8 | 43.3 | 196 | H24 H28 | 6 | 6 |
| 398 | 18 | 19 | 18:16 | 16 | 3.3 | 9.8 | 28.8 | 41.9 | 198 | H24 H28 | 1 | 1 |
| 398 | 18 | 19 | 4:14 | 16 | 1.6 | 7.6 | 17.6 | 26.8 | 200 | H24 H28 | 0 | 1 |
| 398 | 18 | 19 | 5:14 | 16 | 1.9 | 6.0 | 12.9 | 20.7 | 202 | H24 H28 | 0 | 0 |
| 398 | 18 | 19 | 6:24 | 12 | 2.1 | 6.5 | 15.8 | 24.4 | 204 | H24 H28 | 2 | 2 |
| 401 | 19 | 20 | 16:13 | 16 | 2.3 | 8.0 | 14.6 | 24.9 | 206 | H24 H28 | 11 | 14 |
| 401 | 19 | 20 | 17:11 | 16 | 3.3 | 5.9 | 14.3 | 23.5 | 208 | H24 H28 | 8 | 10 |
| 401 | 19 | 20 | 18:13 | 16 | 2.5 | 6.0 | 17.8 | 26.1 | 210 | H24 H28 | 5 | 5 |
| 401 | 19 | 20 | 4:16 | 16 | 2.1 | 6.2 | 13.1 | 21.3 | 212 | H24 H28 | 4 | 4 D' |
| 401 | 19 | 20 | 5:14 | 16 | 1.7 | 6.4 | 14.9 | 23.1 | 214 | H24 H28 | 1 | 0 |
| 401 | 19 | 20 | 6:12 | 16 | 1.4 | 6.7 | 12.2 | 20.3 | 216 | H24 H28 | 4 | 5 |
| 404 | 20 | 21 | 16:17 | 16 | 1.0 | 1.6 | 3.2 | 5.8 | 218 | H24 H28 | 13 | 13 E' |
| 404 | 20 | 21 | 17:15 | 16 | 1.8 | 6.1 | 13.9 | 27.7 | 220 | H24 H28 | 11 | 13 |
| 404 | 20 | 21 | 18:15 | 16 | 1.5 | 5.9 | 17.7 | 25.1 | 222 | H24 H28 | 8 | 11 |
| 404 | 20 | 21 | 4:18 | 16 | 1.8 | 5.7 | 18.4 | 25.9 | 224 | H24 H28 | 5 | 7 |
| 404 | 20 | 21 | 5:12 | 16 | 2.1 | 5.3 | 15.0 | 22.3 | 226 | H24 H28 | 2 | 3 |
| 404 | 20 | 21 | 6:14 | 16 | 2.3 | 4.9 | 14.3 | 21.4 | 228 | H24 H28 | 2 | 2 |
| 407 | 21 | 22 | 16:15 | 16 | 2.8 | 45.1 | 65.8 | 113.7 | 230 | H24 H28 | 4 | 4 |
| 407 | 21 | 22 | 17:21 | 16 | 1.3 | 10.5 | 36.2 | 48.0 | 232 | H24 H28 | 5 | 6 |

ROCKBURST RESEARCH 1938-45

159

| Rec | Fr | To | Epoch | AP | L | M | S | T | N | Con-Rec | Co'ce | Notes |
|-----|----|----|--------------|----|-----|-----|------|------|-----|---------|-------|-------|
| 407 | 21 | 22 | 18:15 | 16 | 1.9 | 6.6 | 32.6 | 41.1 | 234 | H24 H28 | 4 5 | |
| 407 | 21 | 22 | 4:16 | 16 | 3.8 | 8.3 | 21.2 | 33.2 | 236 | H24 H28 | 7 9 | F' |
| 407 | 21 | 22 | 5:14 | 16 | 3.6 | 6.6 | 19.9 | 30.2 | 238 | H24 H28 | 9 13 | G' |
| 407 | 21 | 22 | 6:14 | 16 | 2.4 | 5.0 | 15.5 | 22.9 | 240 | H24 H28 | 4 4 | |
| 410 | 22 | 23 | 16:21 | 16 | 1.1 | 7.2 | 38.8 | 47.1 | 242 | H24 H28 | 2 2 | |
| 410 | 22 | 23 | 17:17 | 16 | 1.1 | 5.2 | 29.2 | 35.5 | 244 | H24 H28 | 1 4 | |
| 410 | 22 | 23 | 18:17 | 16 | 1.1 | 3.3 | 23.8 | 28.2 | 246 | H24 H28 | 3 4 | |
| 410 | 22 | 23 | 4:15 | 16 | 2.2 | 4.8 | 24.1 | 31.1 | 248 | H24 H28 | 1 1 | |
| 410 | 22 | 23 | 5:15 | 16 | 2.1 | 4.1 | 19.4 | 25.5 | 250 | H24 H28 | 3 3 | |
| 410 | 22 | 23 | 6:15 | 16 | 2.8 | 4.8 | 18.0 | 25.6 | 252 | H24 H28 | 6 6 | |
| 413 | 23 | 25 | 16:15 | 16 | 1.6 | 5.1 | 23.1 | 29.7 | 254 | H24 H28 | 1 1 | |
| 413 | 23 | 25 | 17:15 | 16 | 1.1 | 4.4 | 16.5 | 21.9 | 256 | H24 H28 | 3 4 | |
| 413 | 23 | 25 | 18:15 | 16 | 1.4 | 4.3 | 16.9 | 21.6 | 258 | H24 H28 | 1 2 | H' |
| 413 | 23 | 25 | 4:17 | 16 | 3.8 | 5.2 | 13.4 | 22.4 | 260 | H24 H28 | 2 5 | |
| 413 | 23 | 25 | 5:19 | 16 | 2.7 | 4.9 | 13.5 | 21.1 | 262 | H24 H28 | 5 5 | |
| 413 | 23 | 25 | 6:17 | 16 | 2.9 | 4.6 | 11.6 | 19.0 | 264 | H24 H28 | 8 8 | |
| 413 | 23 | 25 | <u>16:17</u> | 16 | 1.4 | 3.4 | 9.5 | 14.4 | 266 | H24 H28 | 2 3 | |
| 413 | 23 | 25 | <u>17:17</u> | 16 | 1.1 | 4.3 | 11.3 | 16.7 | 268 | H24 H28 | 3 4 | |
| 413 | 23 | 25 | <u>18:19</u> | 16 | 1.8 | 3.8 | 11.3 | 16.9 | 270 | H24 H28 | 8 11 | |
| 413 | 23 | 25 | <u>4:19</u> | 16 | 1.0 | 3.6 | 9.8 | 14.4 | 272 | H24 H28 | 1 1 | |
| 413 | 23 | 25 | <u>5:21</u> | 16 | 1.1 | 3.7 | 10.0 | 14.8 | 274 | H24 H28 | 3 3 | |

DOMINION OBSERVATORY

| Rec | Fr | To | Epoch | AP | L | M | S | T | N | Con-Rec | Co'ce | Notes |
|-----|----|----|-------------|----|-----|-----|------|------|-----|---------|-------|-------|
| 413 | 23 | 25 | <u>6:21</u> | 16 | 1.0 | 3.9 | 9.9 | 14.8 | 276 | H24 H28 | 3 | 3 |
| 416 | 25 | 26 | 16:19 | 16 | 1.6 | 3.4 | 10.4 | 15.4 | 278 | H24 H28 | 4 | 4 |
| 416 | 25 | 26 | 17:23 | 16 | 2.0 | 4.8 | 11.4 | 18.2 | 280 | H24 H28 | 2 | 2 I' |
| 416 | 25 | 26 | 18:17 | 16 | 1.1 | 2.9 | 9.0 | 13.1 | 282 | H24 H28 | 3 | 4 |
| 416 | 25 | 26 | 4:17 | 16 | .6 | 2.8 | 8.8 | 12.1 | 284 | H24 H28 | 2 | 3 |
| 416 | 25 | 26 | 5:17 | 16 | .8 | 2.5 | 8.9 | 12.1 | 286 | H24 H28 | 2 | 3 |
| 416 | 25 | 26 | 6:17 | 16 | 1.1 | 3.6 | 19.4 | 24.2 | 288 | H24 H28 | 4 | 5 |
| 419 | 26 | 27 | 16:21 | 16 | .6 | 2.9 | 15.3 | 18.8 | 290 | H24 H28 | 4 | 4 J' |
| 419 | 26 | 27 | 17:17 | 16 | .9 | 2.8 | 10.1 | 13.8 | 292 | H24 H28 | 3 | 3 |
| 419 | 26 | 27 | 18:17 | 16 | .8 | 2.3 | 10.1 | 13.1 | 294 | H24 H28 | 4 | 5 |
| 419 | 26 | 27 | 4:21 | 16 | .4 | 2.7 | 19.9 | 22.9 | 296 | H24 H28 | 1 | 1 |
| 419 | 26 | 27 | 5:17 | 16 | .8 | 2.3 | 10.6 | 13.7 | 298 | H24 H28 | 3 | 5 |
| 419 | 26 | 27 | 6:23 | 16 | .8 | 2.0 | 10.0 | 12.8 | 300 | H24 H28 | 0 | 0 |
| 422 | 27 | 28 | 16:17 | 16 | 3.4 | 5.5 | 12.1 | 21.0 | 302 | H24 H28 | 26 | 45 |
| 422 | 27 | 28 | 17:17 | 16 | 1.7 | 4.1 | 8.6 | 14.4 | 304 | H24 H28 | 0 | 0 |
| 422 | 27 | 28 | 18:17 | 16 | 1.6 | 3.6 | 11.1 | 16.4 | 306 | H24 H28 | 5 | 6 |
| 422 | 27 | 28 | 4:17 | 16 | 1.0 | 2.8 | 12.5 | 16.3 | 308 | H24 H28 | 0 | 3 |
| 422 | 27 | 28 | 5:17 | 16 | .7 | 3.1 | 9.0 | 12.8 | 310 | H24 H28 | 6 | 7 |
| 422 | 27 | 28 | 6:21 | 16 | 1.9 | 4.7 | 12.1 | 18.7 | 312 | H24 H28 | 9 | 9 |

The burst of January 29 occurred at 2:12 a.m., 19^h 12^m after the record No. 422 was completed at 7 a.m., January 28.

- A. Entire record was useless, owing to open circuit.
- B. Entire record was useless, owing to open circuit.
- C. Coincidences between record 368 (H29) and the other concurrent holes 367(H27) and 366(H29) are difficult to determine, owing to extremely active conditions on 3801W-9.
- D. A most peculiar record (Jan. 6); almost quiescent except for salvoes of short duration — about a minute. On January 8 we found bad contacts in an amphenol coupling. No listening was done on 3801W-9 on Jan. 6. Geophone was reset Jan. 5, being inserted only about 12 ft. Stylus voltage too high throughout the record.
- E. New schedule begun, 4^h-7^h a.m., and p.m., alternating holes every half hour.
- F. Omitting salvoes, the count was only about .6 s.p.m., which is of so little value that it is not tabulated.
- G. Beginning at 4 a.m. January 7, the character of the record changed to almost continuous small offsets. They are not 'static' and seem real. They follow blasting.
- H. A heavy salvo omitted from the count. Snaps very numerous of this record 371(H29).
- I. The geophone was reset to a full depth of 30 ft. Record 371(H29) for January 6-7 was poor, largely because of poor contacts at the amphenol coupling. The hole was reamed on January 7, to permit the geophone to be reset to its full depth.
- J. Voltage too high on stylus. Centre broken towards the end of the record.
- K. Record 377(H28, H25), for January 9-11 is useless, owing to mistake in setting attenuator after modifications to the recorder.
- L. Stylus voltage too high towards the end of the record.
- M. Record 382(H29) having time-switch trouble this part of the run.
- N. The first section of this record completely analysed into 9 classes.
- O. Salvoes of small intensity merged in the records appear on page 38302. One of these was disregarded in the count.
- P. Coincidences checked out by E.A.H. from record books, as there had been an error in comparing records.
- Q. Short salvo at 6:03 p.m. January 12. See page 38313A*.
- R. Record 383(H29) turned off at 6:45 p.m. January 12 by accidental change in setting of the program clock.
- S. Record fails to show traces of the salvoes shown on record 385(H24) and 384(H28)
- T. See note U for H25. (omitted in this publication).
- U. Record ran only 14 min. when it was turned off by accidental change in setting the program clock. The coincidences with 385(H24) and 384(H28) are thus for 15 min. only. From 5:15 a.m. January 13 to the end of the run the coincidences are all out and the counts for the two geophones are mixed. They are therefore omitted. They could be deduced for 14 min. intervals if care were taken, as some coincidences do exist to identify the times on this record.
- V. Time switch gave trouble, leading to a somewhat shortened record for some runs during the 24 hrs. and quite spoiling some others. Note: E.G. began checking totals and coincidences at the beginning of this record, continuing to the end of this report.
- W. A burst registered on record 386(H29), beginning just before 7 p.m. January 13 (see page 38618A.) This burst registered as a single offset on H27 and H25 (see

* Figures of this type of course refer to the machine records as put up in book form.

- pp. 38818A and 38718A — marked N on the records).
- X. See Note S for H24 (not included in this publication).
- Z. Record shows bunching of offsets quite markedly.
- A' A rather long and open salvo began about 4:13 a.m. January 16 and continued for about 5 min. It was marked by a wide zero with much small activity on H24, by discrete offsets of all types on H25 and by a slightly wider zero with activity both large, medium, and small on H29. Compare pages 39419, 39319, and 39219. Another short salvo appears on H24 at about 4:27 and continues for 2 min. It shows heavy snaps on H25, likewise (but fewer) on H29. Compare pages 39421A, 39321A, and 39221A.
- B' This activity so great only 2 min. counted. The coincidences with H29 were, however, checked over for 16 min.
- C' Small salvo beginning about 4:06 p.m. January 18 on H29. No trace on H24 or H28. Compare pages 40002A, 39902A, and 39802A, at point marked X.
- D' See note S for H28, regarding a short salvo at 4:17 a.m. January 20 which was well marked on H28 and H24. There was practically no trace on H29 at that time, but there were many very small salvos on H29 during the run 4-4:30. One of these appears about 4:19 with two others on page 40120B immediately following. These are represented on H28 and H24 by sharp single snaps.
- E' Between 4:05 and 4:07 p.m. January 20, a series of what look like blasts recorded on H28, but not on H24, or H29, which ran concurrently. A short burst recorded on H29 at 4:06 but no trace of it, except as a single snap, appears on H24 or H28. Compare pages 40602A, 40502A, and 40402A.
- F' See note X for H28 (omitted from this publication).
- G' Snaps come in little groups which almost become small bursts. See page 40725B at point marked M.
- H' Stylus voltage too high.
- I' Rather ill-defined salvo lasting about a minute, began at 5:24 p.m. January 25 on H29. No trace on H24 or H28. See pages 41809A, 41709A, and 41609A.
- J' See note D' for H28 (omitted from this publication).

H31

| Rec | Fr | To | Epoch | AP | L | M | S | T | N | Con-Rec | Co'ce | Notes | |
|-----|----|----|-------|----|---|---|---|---|----|---------|-------|-------|-----|
| | Ja | Ja | | | | | | | | | | | |
| 382 | 11 | 12 | 16:19 | - | - | - | - | - | 92 | H27 H25 | - | - | A |
| 382 | 11 | 12 | 17:15 | - | - | - | - | - | 94 | H27 H25 | - | - | A |
| 382 | 11 | 12 | 18:11 | - | - | - | - | - | 96 | H27 H25 | - | - | A |
| 382 | 11 | 12 | 4:12 | - | - | - | - | - | 98 | H27 H25 | - | - | A,B |

| Rec | Fr | To | Epoch | AP | L | M | S | T | N | Con-Rec | Co'ce | Notes |
|-----|----|----|-------|----|-----|-----|------|------|--------|---------|-------|-------|
| 382 | 11 | 12 | 5:16 | -- | -- | -- | -- | -- | 100 | H27 H25 | -- -- | A,C |
| 382 | 11 | 12 | 6:18 | 12 | 1.6 | 6.8 | 32.8 | 41.1 | 102 | H27 H25 | 4 4 | D |
| 386 | 13 | 14 | 16:46 | 24 | 1.0 | 4.2 | 9.1 | 14.3 | 130-31 | H27 H25 | 11 10 | E |
| 386 | 13 | 14 | 17:47 | -- | -- | -- | -- | -- | 134-35 | H27 H25 | -- -- | E |
| 386 | 13 | 14 | 18:47 | -- | -- | -- | -- | -- | 138-39 | H27 H25 | -- -- | E |
| 386 | 13 | 14 | 4:48 | -- | -- | -- | -- | -- | 141 | H27 H25 | -- -- | E,F |
| 386 | 13 | 14 | 5:57 | -- | -- | -- | -- | -- | 143 | H27 H25 | -- -- | E |
| 386 | 13 | 14 | 6:40 | -- | -- | -- | -- | -- | 145 | H27 H25 | -- -- | E |
| | Ja | Ja | | | | | | | | | | |
| 389 | 14 | 15 | 16:41 | -- | -- | -- | -- | -- | 147 | H27 H25 | -- -- | G,H |
| 389 | 14 | 15 | 17:51 | -- | -- | -- | -- | -- | 149 | H27 H25 | -- -- | G |
| 389 | 14 | 15 | 18:47 | -- | -- | -- | -- | -- | 151 | H27 H25 | -- -- | G |
| 389 | 14 | 15 | 4:42 | -- | -- | -- | -- | -- | 153 | H27 H25 | -- -- | G, I |
| 389 | 14 | 15 | 5:42 | -- | -- | -- | -- | -- | 155 | H27 H25 | -- -- | G |
| 389 | 14 | 15 | 6:50 | 16 | .6 | 4.1 | 10.4 | 15.1 | 157 | H27 H25 | 1 3 | |
| 392 | 15 | 16 | 16:52 | 16 | 1.0 | 3.9 | 6.4 | 11.3 | 159 | H27 H25 | 14 14 | |
| 392 | 15 | 16 | 17:42 | 16 | .6 | 3.6 | 6.7 | 10.8 | 161 | H27 H25 | 8 8 | |
| 392 | 15 | 16 | 18:42 | 16 | .3 | 3.8 | 11.3 | 15.3 | 163 | H27 H25 | 3 4 | |
| 392 | 15 | 16 | 4:40 | 16 | .6 | 8.7 | 15.2 | 24.2 | 165 | H27 H25 | 12 13 | |
| 392 | 15 | 16 | 5:46 | 16 | .1 | 6.6 | 9.3 | 15.9 | 167 | H27 H25 | 9 9 | |
| 392 | 15 | 16 | 6:42 | 16 | .4 | 5.3 | 10.4 | 16.1 | 169 | H27 H25 | 11 11 | |
| 395 | 16 | 18 | 16:40 | 16 | .8 | 5.3 | 12.9 | 18.9 | 171 | H27 H25 | 9 9 | |

| Rec | Fr | To | Epoch | AP | L | M | S | T | N | Con-Rec | Co'ce | Notes |
|-----|----|----|--------------|----|-----|------|------|-------|-----|---------|-------|-------|
| 395 | 16 | 18 | 17:41 | 16 | .4 | .8 | 4.7 | 5.9 | 173 | H27 H25 | 8 8 | |
| 395 | 16 | 18 | 18:41 | 16 | .4 | 5.2 | 29.0 | 34.6 | 175 | H27 H25 | 6 7 | |
| 395 | 16 | 18 | 4:40 | 16 | .3 | 10.3 | 15.4 | 26.0 | 177 | H27 H25 | 3 3 | |
| 395 | 16 | 18 | 5:42 | 16 | .6 | 8.8 | 12.9 | 22.4 | 179 | H27 H25 | 11 12 | |
| 395 | 16 | 18 | 6:46 | 16 | .5 | 7.3 | 12.9 | 20.6 | 181 | H27 H25 | 8 8 | |
| 395 | 16 | 18 | <u>16:50</u> | 16 | .7 | 6.1 | 40.8 | 47.6 | 183 | H27 H25 | 3 3 | |
| 395 | 16 | 18 | <u>17:46</u> | 16 | .2 | 4.8 | 34.7 | 39.6 | 185 | H27 H25 | 0 1 | |
| 395 | 16 | 18 | <u>18:48</u> | 16 | .1 | 6.8 | 43.6 | 50.5 | 187 | H27 H25 | 6 6 | |
| 395 | 16 | 18 | <u>4:44</u> | 16 | .3 | 17.5 | 60.9 | 78.7 | 189 | H27 H25 | 2 2 | J |
| 395 | 16 | 18 | <u>5:31</u> | 2 | 9.0 | 43.0 | 93.0 | 145.0 | 191 | H27 H25 | 0 0 | K |
| 395 | 16 | 18 | <u>6:41</u> | 2 | 4.0 | 35.0 | 88.0 | 127.0 | 193 | H27 H25 | 0 0 | |
| 398 | 18 | 19 | 16:45 | 16 | 1.3 | 4.7 | 15.2 | 21.1 | 195 | H27 H25 | 13 12 | |
| 398 | 18 | 19 | 17:43 | 16 | 1.2 | 4.1 | 12.2 | 17.4 | 197 | H27 H25 | 9 9 | |
| 398 | 18 | 19 | 18:42 | 16 | .4 | 5.9 | 16.5 | 22.7 | 199 | H27 H25 | 5 3 | |
| 398 | 18 | 19 | 4:42 | 16 | .8 | 11.6 | 27.6 | 39.9 | 201 | H27 H25 | 2 2 | |
| 398 | 18 | 19 | 5:42 | 16 | .6 | 10.6 | 22.1 | 33.3 | 203 | H27 H25 | 1 1 | |
| 398 | 18 | 19 | 6:42 | 16 | .3 | 15.2 | 38.6 | 54.6 | 205 | H27 H25 | 1 1 | |
| 401 | 19 | 20 | 16:41 | 16 | 2.1 | 3.8 | 8.6 | 14.5 | 207 | H27 H25 | 14 14 | L |
| 401 | 19 | 20 | 17:43 | 16 | 1.8 | 3.3 | 6.9 | 12.0 | 209 | H27 H25 | 13 13 | |
| 401 | 19 | 20 | 18:41 | 16 | .8 | 2.9 | 6.3 | 10.0 | 211 | H27 H25 | 10 10 | |
| 401 | 19 | 20 | 4:42 | 16 | .8 | 3.4 | 17.9 | 22.1 | 213 | H27 H25 | 8 8 | |
| 401 | 19 | 20 | 5:44 | 16 | .4 | 3.1 | 9.9 | 13.4 | 215 | H27 H25 | 6 6 | |

ROCKBURST RESEARCH 1938-45

165

| Rec | Fr | To | Epoch | AP | L | M | S | T | N | Con-Rec | Co'ce | Notes |
|-----|----|----|-------|----|-----|-----|------|------|-----|---------|-------|-------|
| 401 | 19 | 20 | 6:44 | 16 | .4 | 2.7 | 8.8 | 11.8 | 217 | H27 H25 | 7 | 7 |
| 404 | 20 | 21 | 16:43 | 16 | .6 | 2.4 | 8.5 | 11.6 | 219 | H27 H25 | 10 | 11 |
| 404 | 20 | 21 | 17:43 | 16 | .7 | 2.1 | 6.4 | 9.3 | 221 | H27 H25 | 8 | 10 |
| 404 | 20 | 21 | 18:47 | 16 | .6 | 2.5 | 6.3 | 9.4 | 223 | H27 H25 | 9 | 13 |
| 404 | 20 | 21 | 4:46 | 16 | 1.1 | 3.6 | 11.9 | 16.6 | 225 | H27 H25 | 11 | 11 |
| 404 | 20 | 21 | 5:44 | 16 | 1.2 | 3.2 | 8.9 | 13.3 | 227 | H27 H25 | 14 | 16 |
| 404 | 20 | 21 | 6:44 | 16 | 1.3 | 4.2 | 8.8 | 14.2 | 229 | H27 H25 | 9 | 11 |
| 407 | 21 | 22 | 16:43 | 16 | 1.8 | 3.3 | 8.1 | 13.2 | 231 | H27 H25 | 17 | 19 |
| 407 | 21 | 22 | 17:43 | 16 | .9 | 1.9 | 8.8 | 11.6 | 233 | H27 H25 | 10 | 12 |
| 407 | 21 | 22 | 18:43 | 16 | .6 | 2.6 | 8.9 | 12.1 | 235 | H27 H25 | 9 | 10 |
| 407 | 21 | 22 | 4:42 | 16 | 2.3 | 4.3 | 20.2 | 26.7 | 237 | H27 H25 | 11 | 11 |
| 407 | 21 | 22 | 5:44 | 16 | 1.5 | 2.1 | 12.4 | 16.0 | 239 | H27 H25 | 9 | 13 |
| 407 | 21 | 22 | 6:44 | 16 | .9 | 3.4 | 11.3 | 15.6 | 241 | H27 H25 | 5 | 5 |
| 410 | 22 | 23 | 16:47 | 16 | 1.3 | 3.3 | 10.6 | 15.6 | 243 | H27 H25 | 19 | 24 |
| 410 | 22 | 23 | 17:47 | 16 | 1.4 | 3.5 | 9.3 | 14.2 | 245 | H27 H25 | 6 | 6 |
| 410 | 22 | 23 | 18:47 | 16 | 1.1 | 2.4 | 9.7 | 13.2 | 247 | H27 H25 | 12 | 12 |
| 410 | 22 | 23 | 4:47 | 16 | 1.9 | 3.9 | 24.3 | 30.1 | 249 | H27 H25 | 8 | 8 |
| 410 | 22 | 23 | 5:47 | 16 | 1.4 | 2.6 | 17.1 | 21.2 | 251 | H27 H25 | 11 | 13 |
| 410 | 22 | 23 | 6:47 | 16 | 1.4 | 3.9 | 18.4 | 23.8 | 253 | H27 H25 | 11 | 13 |
| 413 | 23 | 25 | 16:43 | 16 | 1.7 | 3.7 | 11.4 | 16.8 | 255 | H27 H25 | 10 | 10 |
| 413 | 23 | 25 | 17:43 | 16 | 1.3 | 3.0 | 11.1 | 15.3 | 257 | H27 H25 | 7 | 10 |
| 413 | 23 | 25 | 18:43 | 16 | 1.0 | 3.6 | 13.1 | 21.7 | 259 | H27 H25 | 11 | 13 |
| 413 | 23 | 25 | 4:45 | 16 | 1.6 | 6.8 | 25.1 | 33.5 | 261 | H27 H25 | 8 | 8 M |

DOMINION OBSERVATORY

| Rec | Fr | To | Epoch | AP | L | M | S | T | N | Con-Rec | Co'ce | Notes |
|-----|----|----|--------------|----|-----|------|------|-------|-----|---------|-------|-------|
| 413 | 23 | 25 | 5:45 | 16 | 1.4 | 3.4 | 18.9 | 23.7 | 263 | H27 H25 | 8 9 | |
| 413 | 23 | 25 | 6:45 | 16 | 1.8 | 3.8 | 9.4 | 14.9 | 265 | H27 H25 | 10 11 | |
| 413 | 23 | 25 | <u>16:49</u> | 16 | 1.1 | 3.3 | 8.8 | 13.1 | 267 | H27 H25 | 9 9 | |
| 413 | 23 | 25 | <u>17:49</u> | - | - | - | - | - | 269 | H27 H25 | - - | M |
| 413 | 23 | 25 | <u>18:45</u> | 16 | 1.3 | 3.8 | 29.0 | 34.1 | 271 | H27 H25 | 4 4 | O |
| 413 | 23 | 25 | <u>4:45</u> | 16 | 1.1 | 4.1 | 37.4 | 42.7 | 273 | H27 H25 | - - | P |
| 413 | 23 | 25 | <u>5:45</u> | - | - | - | - | - | 275 | H27 H25 | - - | P |
| | Ja | Ja | | | | | | | | | | |
| 413 | 23 | 25 | <u>6:51</u> | 16 | 1.3 | 3.1 | 67.4 | 71.8 | 277 | H27 H25 | 6 7 | Q |
| 416 | 25 | 26 | 16:49 | 16 | 1.5 | 6.6 | 35.5 | 43.6 | 279 | H27 H25 | 3 3 | |
| 416 | 25 | 26 | 17:47 | 16 | 1.0 | 4.9 | 34.8 | 40.7 | 281 | H27 H25 | 11 14 | |
| 416 | 25 | 26 | 18:45 | 16 | .9 | 4.4 | 30.4 | 35.8 | 283 | H27 H25 | 10 17 | |
| 416 | 25 | 26 | 4:51 | 16 | .7 | 5.9 | 49.6 | 56.2 | 285 | H27 H25 | 0 1 | R |
| 416 | 25 | 26 | 5:53 | 16 | 1.2 | 4.6 | 43.8 | 49.6 | 287 | H27 H25 | 0 1 | |
| 416 | 25 | 26 | 6:49 | 16 | .6 | 5.6 | 70.4 | 76.6 | 289 | H27 H25 | 1 1 | |
| 419 | 26 | 27 | 16:47 | 16 | .8 | 5.2 | 47.3 | 53.3 | 291 | H27 H25 | 12 13 | S |
| 419 | 26 | 27 | 17:45 | 16 | 1.3 | 3.2 | 41.8 | 46.3 | 293 | H27 H25 | 14 14 | |
| 419 | 26 | 27 | 18:45 | 16 | 1.2 | 4.2 | 47.4 | 52.8 | 295 | H27 H25 | 9 11 | T |
| 419 | 26 | 27 | 4:47 | 16 | 1.7 | 11.7 | 84.1 | 97.4 | 297 | H27 H25 | 1 2 | |
| 419 | 26 | 27 | 5:53 | 16 | .9 | 12.1 | 76.1 | 89.1 | 299 | H27 H25 | 0 0 | |
| 419 | 26 | 27 | 6:51 | 16 | 1.0 | 13.3 | 73.5 | 87.8 | 301 | H27 H25 | 0 0 | |
| 422 | 27 | 28 | 16:45 | 2 | 4.5 | 40.5 | 92.0 | 137.0 | 303 | H27 H25 | 5 5 | U |
| 422 | 27 | 28 | 17:49 | 16 | 2.3 | 33.7 | 60.5 | 96.4 | 305 | H27 H25 | 4 4 | |

| Rec | Fr | To | Epoch | AP | L | M | S | T | N | Con-Rec | Cc'ce | Notes |
|-----|----|----|-------|----|-----|------|------|------|-----|---------|-------|-------|
| 422 | 27 | 28 | 18:47 | 16 | 1.6 | 26.0 | 56.9 | 84.5 | 307 | H27 H25 | 1 1 | |
| 422 | 27 | 28 | 4:47 | 16 | 1.5 | 16.3 | 51.3 | 69.1 | 309 | H27 H25 | 5 5 | |
| 422 | 27 | 28 | 5:44 | 14 | .5 | 18.5 | 44.8 | 63.8 | 311 | H27 H25 | 4 4 | V |
| 422 | 27 | 28 | 6:45 | 16 | 2.4 | 16.5 | 38.9 | 57.9 | 313 | H27 H25 | 10 10 | W |

- A. First record on 3801W-9 with two geophones (H29, H31). Time switch spoiled much of the record. Voltage was too high on styli.
- B. Long salvo beginning 4:10 and lasting 4 min. followed by another beginning 4:16 and lasting 4+ min. running into time-switch change. Some traces of these on record 381(H27) and record 380(H25), but not nearly as much as on this record 380(H31).
- C. Reference to Note P (H25) omitted from this publication.
- D. Time switch worked all right till 4 min. before the end of the comparison run. Thus coincidences with record 381(H27) and record 380(H25) are for 12 min. only.
- E. Time switch gave some trouble, leading to a somewhat shorter record for some runs for the 24 hrs. and totally spoiling some others (Note: Began reading for shorter periods, owing to pressure of work).
- F. Reference to H25, omitted from this publication
- G. Time switch gave trouble on H31.
- H. What may have been a burst shows only on 389(H31)? just about the time the switch changed. No trace on other records. See page 38904.
- I. What may have been a burst shows only on 389(H31). Does not appear on other records. Began about 4:42 a.m. January 15 and lasted 3 min. See page 38922B.
- J. A light trace of a salvo at 4:38 a.m. January 18; appears on H31 only. No trace on H27 or H25. See page 39556A.
- K. So active that only 2 min. were read (by E.A.H. on April 14). Sudden sharp increase on a Monday morning when no work was done since early Sunday morning. Compare pages 39556A (4:32 a.m. January 18); 39561B (5:32 a.m. January 18); 39567A (6:32 a.m. January 18).
- L. A short salvo of strong offsets lasting less than a minute occurred at 4:40 p.m. January 19. It was well marked on H27, H25, and H31. Compare pages 40305A, 40205A, and 40105A.
- M. A series of faintly developed salvos, lasting each about one minute, began at 4:47 a.m. January 24 on H31. They did not appear on H27 or H25 until about 4:57, when they were faintly developed also on H25. Compare pages 41522, 41422, 41322 to 41524, 41424, and 41324.
- N. Poor contact on time switch. Zero very wide.
- O. Stylus voltage too high.
- P. Poor contact on time switch. Record hardly legible.

- Q. This count must be taken with reserve. The time switch contacts were very poor.
- R. Some evidence of ore skipping on this record. See page 41624A and compare with 41824.
- S. Reference to H25, omitted in this publication.
- T. Reference to H25, omitted in this publication.
- U. A small section of H31 came on record 422 on the first page. It lasted only 2 min. before being stopped by the time switch, but the activity recorded was of extraordinary energy. Coincidences with H27 and H25 checked only for 2 min.
- V. A small sharp burst occurred at 5:49 a.m. January 28. It registered for about 2 min. on each record (H27, H25, H31). It was more sharply marked on H25, but there were many more small ones registered on H31. The larger snaps in the burst were as well marked on H27 as on H25. Compare pages 42428, 42328, and 42228.
- W. The set 111 and the records 425(H29, H31) were lost in the burst of January 29, which closed the drift 3801W for more than 300 ft.

L-13 Salvoes and Bursts Registered in January 1943

In the following tabulation, the successive headings indicate:

| | | |
|--------------|---|--|
| No | = | Serial number assigned to the disturbance. |
| Ja | = | The January date. |
| T | = | Type: burst or salvo. |
| Began | = | Nearest minute when the disturbance started, given in Eastern War Time on the 24-hr. system beginning at midnight. |
| Dur | = | The duration, to the nearest half-minute. |
| Con-Rec | = | The concurrent records running at the time of the disturbance. |
| Con-Rec Page | = | Page of the record where the disturbance registered, inserted for use in referring to the registration. |
| Inten | = | The estimated intensity on an ascending scale of 5. |
| Rem | = | A series of indexed remarks following the table. |

Note: These so-called 'salvoes' are extremely local in their registration. They seem to occur when pressures are building up, and to become few or absent after large bursts. The choice of the name is perhaps unfortunate, but it was the one adopted at the time they were first noticed. See figure 47.

| No. | Ja | T | Began | Dur | Con-Rec | Con-Rec Pages | Inten | Rem |
|-----|----|---|-------|-----|-------------|-------------------|-------|-----|
| 1 | 5 | S | 4:39 | 2.0 | H29 H28 H24 | 36516 36316 36416 | - 3 | 3 |
| 2 | 6 | S | 16:11 | 0.5 | H29 H28 H24 | 37102 36902 37002 | 1 - - | A |

ROCKBURST RESEARCH 1938-45

169

| No | Ja | T | Began | Dur | Con-Rec | | | Con-Rec | Pages | Inten | | | Rem | |
|----|----|---|-------|-----|---------|-----|-----|---------|-------|-------|---|---|-----|-----|
| 3 | 6 | S | 16:13 | 1.0 | H29 | H28 | H24 | 37102 | 36902 | 37002 | 1 | - | - | A |
| 4 | 6 | S | 16:15 | 1.0 | H29 | H28 | H24 | 37102 | 36902 | 37002 | 2 | - | - | A |
| 5 | 6 | S | 16:22 | 2.0 | H29 | H28 | H24 | 37103 | 36903 | 37003 | 2 | - | - | A |
| 6 | 6 | S | 16:40 | 4.0 | H29 | H28 | H24 | 37105 | 36905 | 37005 | 2 | - | - | A |
| 7 | 8 | S | 4:16 | 4.0 | H27 | H25 | - | 37319 | 37219 | - | - | 3 | - | B,C |
| 8 | 8 | S | 4:22 | 2.0 | H27 | H25 | - | 37320 | 37220 | - | - | 3 | - | B,C |
| 9 | 8 | S | 4:28 | 2.0 | H27 | H25 | - | 37321 | 37221 | - | - | 2 | - | B,C |
| 10 | 9 | S | 4:16 | 4.0 | H29 | H25 | H28 | 37619 | 37520 | 37419 | 0 | 2 | 3 | C |
| 11 | 9 | S | 4:22 | 2.5 | H29 | H25 | H28 | 37620 | 37520 | 37420 | 0 | 2 | 3 | C |
| 12 | 9 | S | 4:30 | 7.0 | H29 | H25 | H28 | 37621 | 37521 | 37421 | 0 | ? | 4 | D |
| 13 | 12 | S | 5:02 | 5.0 | H31 | H28 | H24 | 38224 | 38024 | 38124 | - | 3 | - | E |
| 14 | 12 | S | 5:12 | 6.0 | H31 | H28 | H24 | 38225 | 28025 | 28125 | - | 4 | - | E |
| 15 | 12 | B | 16:08 | 1.0 | H29 | H28 | H24 | 38302 | 38402 | 38502 | 2 | 1 | 1 | F |
| 16 | 12 | B | 16:10 | 1.0 | H29 | H28 | H24 | 38302 | 38402 | 38502 | 3 | 1 | 1 | F |
| 17 | 12 | S | 18:37 | 0.5 | H29 | H27 | H25 | 38316 | 38516 | 38416 | 0 | 0 | 2 | |
| 18 | 13 | S | 4:04 | 2.0 | H29 | H28 | H24 | 38317 | 38418 | 38519 | 0 | 3 | 2 | |
| 19 | 13 | S | 4:13 | 2.0 | H29 | H28 | H24 | 38318 | 38419 | 38519 | 0 | 3 | 2 | |
| 20 | 13 | S | 4:23 | 5.0 | H29 | H28 | H24 | 38319 | 38420 | 38520 | 0 | 3 | 2 | |
| 21 | 13 | S | 4:50 | 0.5 | H29 | H27 | H25 | 38322 | 38523 | 38423 | 1 | 2 | 0 | |
| 22 | 13 | S | 5:41 | 1.0 | H29 | H27 | H25 | 38325 | 38528 | 38427 | 0 | 0 | 2 | |
| 23 | 13 | B | 18:59 | 1.5 | H29 | H27 | H25 | 38618 | 38818 | 38718 | 3 | 1 | 1 | G |
| 24 | 14 | B | 4:20 | 0.5 | H29 | H28 | H24 | 38620 | 38720 | 38820 | 1 | 2 | 2 | H |
| 25 | 14 | S | 4:25 | 1.0 | H29 | H28 | H24 | 38620 | 38720 | 38821 | 1 | 3 | 2 | |

DOMINION OBSERVATORY

| No | Ja | T | Began | Dur | Con-Rec | Con-Rec | Pages | Inten | Rem |
|----|----|---|-------|------|-------------|---------|-------|-------|---------|
| 26 | 14 | B | 4:33 | 10.0 | H31 H27 H25 | 38621 | 38821 | 38721 | 0 2 5 I |
| 27 | 14 | S | 4:55 | 1.0 | H31 H27 H25 | 38623 | 38823 | 38723 | 0 0 2 |
| 28 | 14 | S | 4:57 | 1.0 | H31 H27 H25 | 39623 | 38823 | 38723 | 0 0 1 |
| 29 | 14 | S | 16:30 | 4.5 | H31 H27 H25 | 38904 | 39104 | 39004 | 4 - 0 J |
| 30 | 15 | S | 4:42 | 3.5 | H31 H27 H25 | 38922 | 39122 | 39022 | 3 0 0 |
| 31 | 15 | B | 16:13 | 0.5 | H29 H25 H24 | 39202 | 39302 | 39002 | 3 5 5 K |
| 32 | 16 | S | 4:13 | 4.5 | H29 H25 H24 | 39219 | 39319 | 39419 | 4 3 2 |
| 33 | 16 | S | 4:27 | 1.5 | H29 H25 H24 | 39221 | 39321 | 39421 | 3 4 4 |
| 34 | 18 | S | 4:38 | 1.0 | H31 H27 H25 | 39556 | 39756 | 39656 | 2 0 0 |
| 35 | 18 | S | 16:06 | 1.0 | H29 H28 H24 | 39802 | 39902 | 40002 | 2 0 0 |
| 36 | 19 | S | 16:40 | 1.5 | H31 H27 H25 | 40105 | 40305 | 40205 | 3 5 5 K |
| 37 | 20 | S | 4:18 | 0.5 | H29 H28 H24 | 40120 | 40220 | 40320 | 2 2 2 L |
| 38 | 20 | S | 5:25 | 1.0 | H29 H28 H24 | 40126 | 40226 | 40226 | 1 1 1 |
| 39 | 20 | S | 16:06 | 0.5 | H29 H28 H24 | 40402 | 40502 | 40602 | 3 2 2 M |
| 40 | 21 | S | 4:07 | 0.5 | H29 H28 H24 | 40419 | 40519 | 40619 | 0 2 2 |
| 41 | 21 | S | 4:46 | 0.5 | H31 H27 H25 | 40422 | 40623 | 40522 | 1 1 2 |
| 42 | 21 | B | 16:03 | 0.5 | H29 H28 H24 | 40701 | 40801 | 40901 | 2 3 3 N |
| 43 | 21 | S | 16:28 | 2.0 | H29 H28 H24 | 40704 | 40804 | 40904 | 1 4 3 O |
| 44 | 22 | S | 4:26 | 2.0 | H29 H28 H24 | 40721 | 40821 | 40921 | 1 5 3 |
| 45 | 22 | S | 5:16 | 0.5 | H29 H28 H24 | 40725 | 40825 | 40925 | 2 1 0 |
| 46 | 22 | S | 16:13 | 0.5 | H29 H28 H24 | 41002 | 41102 | 41202 | 0 4 3 |
| 47 | 22 | S | 16:47 | 0.5 | H31 H27 H25 | 41005 | 41205 | 41105 | 0 0 2 |
| 48 | 23 | S | 5:32 | 0.5 | H29 H28 H24 | 41027 | 41126 | 41227 | 1 3 2 |

| No | Ja | T | Began | Dur | Con-Rec | Con-Rec | Pages | Inten | Rem |
|----|----|---|-------|-----|-------------|---------|-------------|-------|-----|
| 49 | 24 | S | 4:23 | 0.5 | H29 H28 H24 | 41320 | 41420 41520 | 1 3 | 2 P |
| 50 | 24 | S | 4:47 | 2.0 | H31 H27 H25 | 41322 | 41522 41422 | 2 0 | 0 Q |
| 51 | 25 | S | 17:24 | 1.0 | H29 H28 H24 | 41609 | 41709 41809 | 2 0 | 0 |
| 52 | 26 | S | 4:12 | 4.0 | H29 H28 H24 | 41619 | 41719 41819 | 2 4 | 2 R |
| 53 | 26 | S | 4:19 | 0.5 | H29 H28 H24 | 41620 | 41720 41820 | 1 3 | 0 |
| 54 | 26 | S | 4:25 | 7.0 | H29 H28 H24 | 41620 | 41720 41821 | 2 4 | 2 S |
| 55 | 26 | S | 16:37 | 0.5 | H31 H27 H25 | 41904 | 42104 42004 | 5 5 | 5 |
| 56 | 27 | S | 4:00 | 4.0 | H31 H27 H25 | 41918 | 42118 42017 | 3 3 | 4 T |
| 57 | 27 | S | 4:13 | 4.0 | H29 H28 H24 | 41919 | 42018 42119 | 2 4 | 1 U |
| 58 | 28 | S | 4:14 | 2.0 | H29 H28 H24 | 42219 | 42319 42419 | 2 4 | 1 V |
| 59 | 28 | B | 5:49 | 4.0 | H31 H27 H25 | 42228 | 42428 42328 | 5 3 | 4 |
| 60 | 28 | S | 16:06 | 0.5 | - H25 H24 | - | 42601 42701 | - 5 | 5 W |
| 61 | 28 | S | 16:19 | 0.5 | - H25 H24 | - | 42603 42703 | - 4 | 4 W |

- A. May not be seismic. No trace on concurrent records. H29 was not recording snaps at this time, but these salvos (?) were recorded.
- B. Only H27 and H25 recording at the time of these salvos and H27 was spoiled by bad contacts on the time switch.
- C. May not be seismic but no other cause known. Set was working well on H25. But compare Nos. 7, 8, and 9 with Nos. 10, 11, and 12. Sets working well on H25 and H28 for the latter three salvos. It seems strange that there should be such a close agreement in time for the two successive days.
- D. Time switch changed H25 to H24 and interfered considerably with the record. The salvo began to record on H25 and continued to do so on H24, being less in each case than H28.
- E. Switch trouble interfered with both H31 and H24.
- F. These bursts registered with many closely recorded offsets on H29, but only the initial strong burst and a few strong succeeding snaps registered on H28 and H24.
- G. Strong burst with closely registered snaps on H29. Initial snap on H27 and H24 only.

- H. Small initial snap on H29 and some closely recorded smaller snaps. Larger initial snaps and one large succeeding snap on H28 and H24.
- I. There seems to be nothing the matter with H31 record, but there is no trace of this burst of such outstanding magnitude on H25.
- J. A series of salvoes on H31 just as switch changed. No trace on H25. H27 was having time-switch trouble. May not be seismic.
- K. A short series of all strong snaps, beginning and ending abruptly. Shortly after 4:18 a short salvo registered on H29 with no registration on H28 or H24, except two snaps. During this entire record H29 registration tended to run in groups.
- M. A short salvo registered on H29 with nothing but the larger snaps showing on H28 or H24. But on H28 there was a series of what looks like blasts (at a time when blasting does not occur) which register hardly at all on H29 and only slightly more on H24. It is not known what this disturbance was, but it seems surely to have been seismic. See Note N.
- N. Two sharp bursts registered on H28, slightly less heavily on H24 and still less on H29. But on H28 a series that looks like blasts registered just before this burst; these show very slightly on H29, and only a little more on H24. See Note M.
- O. A series resembling blasts on H28; these are fairly well marked on H24 and hardly to be found on H29. Nearly all record 407(H29, H31) for January 21-22 shows the snaps as having a tendency to occur in groups.
- P. On H29 only the major snaps of the short salvo are registered.
- Q. A series of such small salvoes occurred on H31 and not on H27 or H25. One began at 4:56 a.m. January 24 and lasted about a minute, and another began at 4:59 and lasted about half a minute.
- R. A long-drawn-out salvo on H28 with a recrudescence at 4:15 a.m. January 26. Only the larger snaps registered on H29 and H24.
- S. A long-drawn-out salvo on H28 with a recrudescence at 4:29 and another at 4:31. Registered only faintly on H29 and H24, except for the larger snaps. But on H29 there is a series of groups of snaps at intervals during the period 4:30 to 5:00 a.m. January 26.
- T. A salvo that was best registered on H25 occurred just before the time switch changed. When it did change to H29, H28, H24, the record continued on H28, but did not register on H29 or H24.
- U. A long-drawn-out salvo on H28 that was only partly recorded on H29 or H24. It was preceded on H28 by a few abrupt short salvoes that resemble ore skipping records but were not due to this cause.
- V. Well-marked salvo on H28. Only the larger snaps registered on H29 and the salvo was merely a widening of the zero on H24. It was plainly seismic.
- W. The record 425(H29, H31), for January 28-29 was lost in the crush burst of January 29.

Report M

April 1943 - January 1944

At the end of the period covered by the last report, a heavy rockburst had just taken place (March 31, 1943), completing the destruction of the seismic set-up on the west pillar that had been heavily damaged by the rockburst of January 29.

The west pillar seemed to have been relieved from strain by the two bursts. A short listening program over the various levels showed very low activity. The equipment was therefore to the east side of the mine to levels 4450-4825.

A series of new holes was drilled on these levels in the east drifts at about section 3. As the holes became available, they were placed on the listening program and, as the recorders were made ready for service, came into the recording program.

The present report deals with the studies set up and carried on in the new locale. It seems desirable to preface the account with a statement of the theories and deductions formulated as a result of the program in the west pillar.

M-1 Theories and Deductions Based on West Pillar Survey

The theories and deductions arrived at by the seismic survey operators, as of the summer of 1943, were the result of the experience gained in the west pillar survey. They may be stated as follows:

- A. At Lake Shore, rockbursts are apparently caused entirely by the weight of superincumbent rock, which is unequally distributed owing to the block-faulted structure and the progress of mining. It is believed that there was no inherent strain surviving from the geologic history.
- B. The term 'rockburst' should be extended to include any sudden release of rock strain energy, whether or not it is accompanied by evidence in the mine. The burst may be classified as follows:
 - (a) Crush Bursts, due to failure of rock under compression.
 - (b) Strain Bursts, due to failure of rock in shear or tension.
 - (c) Slip Bursts, due to slipping of rock on fault planes, either exposed or far in the walls. The results of the blow delivered by the elastic rebound from such a slip may involve the fall of loose or the overthrow of timber and equipment, sometimes possibly quite far from the point of the slip which, on the other hand, may be evidenced only by the concussion.

- C. The snapping picked up by the Obert equipment during the off-shift periods consists of at least three classes of snaps:
- (a) General Snapping generally sounding low-pitched, whether heavy or light, and sometimes heard without the equipment; registered through more than one geophone and believed to be due to slipping of breaks or faults and the fracturing of rock, whether loose or in the wall.
 - (b) Local Snapping generally sounding high-pitched, whether heavy or light, and almost never heard without equipment; seldom recording simultaneously on more than one recorder.
 - (c) Distant-local Snapping sounding much like the local type but so faint that the snaps can be picked up, in general, only when listening with earphones, the heaviest ones alone being recorded. Local and distant-local snapping are believed to be indicative of rock yielding under strain, either compression or shear. Some minute fracturing is also probably included.
- D. For some time before a rockburst is imminent, the general snaps tend to become stronger and more frequent and then to diminish in number as the pressure is built up. Moreover, the local type tends to increase, if the locus of pressure is near enough to the geophones (75 ft. for recording, or 200 ft. for listening) to be registered or heard.
- E. If the incidence of local-type snapping increases on several geophones and does not exceed on any one, say, 20 s.p.m. (for the early morning off-shift count), there is no localized danger in that part of the mine adequately serviced by geophones.
- F. If the count for local type exceeds 20 s.p.m. (morning count), close observation should be kept on the stope or stopes affected, especially as the listening is done in the early morning, which time the recorders indicate as being the least active of the day.
- G. If the morning count rises to over 80 s.p.m., the stope concerned should be allowed to rest or, if worked, the next blasting should be made abnormally heavy. High counts do not necessarily indicate an impending burst, but they are an evidence of strain and should be treated with respect, especially until further experience has been gained.

M-2 Test Holes on the East Side

The test holes on the east side (also three on the west side drilled since the list previously given in section K-6) are tabulated below and are shown positioned in plan in Figure 65. It will be noted that:

- A. The holes drilled first were all located in section 2E or 3E. Later, some were drilled in section 4E and still later in section 6E. The explanation of this procedure will appear later in this report.

- B. All except one were diamond drill holes run especially for the survey. All the DD holes after H36 were cored for the first 5 ft. from the collar, and had 6-ft. lengths of inch and a half iron pipe set in, with a foot of the pipe projecting.
- C. Except for two holes drilled for a special purpose in January 1943, no holes were available on the east side, even for the listening program until late in May. The holes in section 6E were not ready for service until late in November.

Test Holes Assigned to Rockburst Research

| No. | DD | Date | Location and Wall | Depth | Remarks |
|-----|------|------------|-------------------|--------|---------------|
| 31 | 3744 | Nov. 6'42 | 3908W-7-S | 29'6" | Replaced H30 |
| 32 | 3808 | Feb. 7'43 | 4201W-5-S | 51'0" | Diagonal |
| 33 | 3829 | Feb. 28'43 | 3801W-6-S | 51'0" | Diagonal |
| 34 | 3780 | Jan. 15'43 | 4701E-2-S | 140'1" | 30° up |
| 35 | 3779 | Jan. 13'43 | 4701E-3-S | 164'7" | 30° up |
| 36 | 3876 | May 25'43 | 4402E-3-S | 29'0" | Fairly solid |
| 37 | 3877 | May 25'43 | 4402E-3-N | 28'9" | Fairly solid |
| 38 | 3878 | May 27'43 | 4401E-3-S | 39'5" | Broken ground |
| 39 | 3881 | May 29'43 | 4702E-3-S | 32'0" | Some seams |
| 40 | 3882 | May 29'43 | 4701E-3-S | 29'3" | Fair ground |
| 41 | 3879 | May 28'43 | 4802E-3-S | 30'0" | Some seams |
| 42 | 3880 | May 28'43 | 4801E-3-S | 32'0" | Fair ground |
| 43 | 3883 | May 31'43 | 4502E-3-S | 30'0" | Good ground |
| 44 | 3884 | June 1'43 | 4501E-3-S | 30'7" | Broken ground |
| 45 | 3899 | June 23'43 | 4501E-4-S | 30'9" | Good ground |
| 46 | 3901 | June 24'43 | 4701E-4-S | 30'0" | Broken ground |

DOMINION OBSERVATORY

| No. | DD | Date | Location and Wall | Depth | Remarks |
|-----|------|------------|----------------------|-------|---------------|
| 47 | ** | | 4702E-2-S | 1'6" | Bootleg |
| 48 | 3974 | Nov. 20'43 | 4502E-6-S | 30'2" | Badly broken |
| 49 | 3975 | Nov. 20'43 | 4401E-6-S | 30'0" | Broken ground |
| 50 | 3976 | Nov. 23'43 | 4501E-6-S | 30'1" | Badly broken |
| 51 | 3977 | Nov. 25'43 | 4701E-6-S | 30'4" | Broken ground |
| 52 | 3978 | Nov. 23'43 | 4802E-6-S | 30'2" | Badly broken |
| 53 | 3979 | Nov. 24'43 | 4801E-6-S | 30'0" | Badly broken |
| 54 | 3980 | Nov. 26'43 | 4702E-6-S | 30'0" | Fair ground |

The dates given in the above tabulation show the time when the hole was finished.

**This hole was a percussion drill hole, hence has no DD number. The time when it was drilled is not known, but it was about the same time as the adjoining holes.

H34 and H35 were drilled upward at an angle so that any water draining into them would find outlet. They were very deep, with the object of trying to find the depth of the so-called 'zone of compression'. It was difficult to keep the geophones from sliding out. These holes were soon partly closed, owing to slipping on fault planes.

M-3 Use Made of Test Holes, April '43 to January '44

As soon as the holes were drilled they were added to the listening program, and continued on that program even when they began recording. The recording program was delayed while the recorders, damaged by the bursts in the west pillar, were being repaired. The following table shows the number of days in each month when the respective holes were recording, the totals at the foot of the tabulation showing the number of such days per month.

Number of Recording Days in East Side Holes
April 1943 — January 1944

| H | Apr | May | Jun | Jul | Aug | Sept | Oct | Nov | Dec | Jan |
|----|-----|-----|-----|-----|-----|------|-----|-----|-----|-----|
| 31 | --- | --- | --- | --- | --- | --- | --- | --- | --- | --- |
| 32 | 30 | 15 | --- | --- | --- | --- | --- | --- | --- | --- |
| 33 | --- | --- | --- | --- | --- | --- | --- | --- | --- | --- |
| 34 | 4 | 31 | 18 | --- | --- | --- | --- | --- | --- | --- |
| 35 | 3 | 31 | 18 | --- | --- | --- | --- | --- | --- | --- |
| 36 | --- | --- | --- | --- | --- | --- | 20 | 30 | 31 | 31 |
| 37 | --- | --- | --- | --- | --- | --- | --- | --- | --- | --- |
| 38 | --- | --- | --- | --- | --- | --- | 20 | 30 | 31 | 31 |
| 39 | --- | --- | 12 | 30 | 2 | 30 | --- | --- | --- | --- |
| 40 | --- | --- | --- | 30 | 31 | 30 | 31 | 30 | 31 | 31 |
| 41 | --- | --- | --- | 19 | 31 | 30 | 31 | 30 | 31 | 31 |
| 42 | --- | --- | --- | 19 | 31 | 30 | 31 | 30 | 31 | 31 |
| 43 | --- | --- | --- | 29 | 31 | 30 | 31 | 30 | 31 | 31 |
| 44 | --- | --- | --- | 20 | 27 | 30 | 31 | 30 | 31 | 31 |
| 45 | --- | --- | --- | 13 | 31 | 30 | 31 | 24 | --- | --- |
| 46 | --- | --- | --- | 8 | 31 | 30 | 31 | 29 | --- | 2 |
| 47 | --- | --- | --- | --- | 27 | 30 | 31 | 30 | 30 | 31 |
| 48 | --- | --- | --- | --- | --- | --- | --- | 2 | 31 | 31 |
| 49 | --- | --- | --- | --- | --- | --- | --- | --- | 23 | 31 |
| 50 | --- | --- | --- | --- | --- | --- | --- | 6 | 31 | 31 |

| H | Apr | May | Jun | Jul | Aug | Sep | Oct | Nov | Dec | Jan |
|----|-----|-----|-----|-----|-----|-----|-----|-----|-----|-----|
| 51 | --- | --- | --- | --- | --- | --- | --- | --- | 29 | 31 |
| 52 | --- | --- | --- | --- | --- | --- | --- | --- | 23 | 26 |
| 53 | --- | --- | --- | --- | --- | --- | --- | --- | 24 | 31 |
| 54 | --- | --- | --- | --- | --- | --- | --- | --- | 31 | 30 |
| T | 37 | 77 | 48 | 168 | 242 | 270 | 288 | 301 | 439 | 461 |

M-4 The Listening Program

After the writer was placed in direct charge of the underground program on July 1, 1942, the listening program was expanded, and for the period reviewed — April 1943 to January 1944 — the following was the regular routine.

From 3 a.m. to 7 a.m., when the mine was deserted, listening was carried out at the 4450, 4575, 4700, and 4825 levels. The records were then removed, and the instruments set for automatic recording. The removed records were then taken to the surface for reduction, and entered on a form in duplicate. The original was left at the mine office, where copies were made for distribution to mine officials, and the duplicate was filed in the survey office.

M-5 Proposed Stope Survey

The studies in the west pillar indicated that the subaudible snaps were indeed generated as a result of rock strain, that the s.p.m. increase as the pressure goes up, and that such high counts presumably indicate critical conditions. Furthermore, it was demonstrated that the high counts did not carry more than about 75 ft. in the rock, also that the points of critical pressure build up very rapidly and may as rapidly move to another location.

It was also shown that automatic recording leaves much to be desired. It can cover a limited section only; it is expensive to set up and to operate; it is difficult to maintain the recording apparatus in efficient operation; and it can operate for a limited time only each day — during off-shift periods.

For these reasons, it would appear that the survey can best be accomplished in practice with portable listening equipment, to be used as conditions indicate that it is desirable. Such conditions can best be interpreted by those in charge of the mining operations.

This listening can be done even in shift time; there are always brief interludes in the noise of mining operations of sufficient duration to permit an operator to detect critical snapping.

The listening should be done at frequent intervals, preferably by one operator assigned for this purpose. In this way, one man can build up experience, making him expert in the interpretation of the activity he hears.

One of the mine employees was assigned to undertake this work, and it was hoped that within a short time the proposed program would prove its value as a safety measure. However, the program fell through almost before it was begun, which the writer considers most unfortunate. He is still* firmly of the opinion that the subaudible method has great possibilities as a protection and that the proposed program is the only way in which such protection can be achieved as a routine service.

M-6 Discussion of Some Research Problems

At various conferences between the officials of the mine and the engineers of the seismic survey, questions were raised which were debated quite generally by all present. It seemed desirable to prepare replies to these questions in the form of a memorandum, which appeared as Appendix I of Report M. It is given here practically in full:

A. Basic Assumptions:

The entire program was based on the suggestion, made independently by the writer and others, that faint, subaudible snapping may be generated in rock subjected to serious strain and that, if such snapping is found to occur, it probably indicates a focus of pressure if, as is to be expected, it proves to be localized. Further, it may offer a means of prediction, if it develops a sufficiently long time before the pressure becomes critical.

B. Subaudible Snapping Proved to Exist, to Attenuate at Short Distances, and Tentatively Assumed to Indicate Strain:

The experiments by Obert in U.S. mines, the experience at Frood in 1942, and all subsequent work at Lake Shore Mines prove that subaudible snapping exists and that it attenuates at short distances, and suggest that it is probably due to rock strain. It is certain that faint, subaudible snaps are sometimes generated in rock that is about to burst or is presumably in a state of serious strain, but there is still a question as to whether it always develops. The noises are real, not static or instrumental, and can be heard over one line when they are recording on another, when the geophones are adjacent in the lay-out. A very good example (among thousands) occurred between 5 and 5:30 a.m., February 12. Snaps counted as distant-local type on other lines could, in many cases, be seen to record on the line from H40.

* In 1957

C. Significance of Rate of Snapping:

It is tentatively assumed that the rate of incidence of the localized high-pitched snapping varies directly with increasing strain. Linearity is not assumed; indeed the change of rate is suspected of accelerating as the strain approaches a critical value. There has been no proof to the contrary as yet, but such noises did develop prior to the burst in 4201W-10 on July 25, 1942; in 3825 and 3950 level geophones in the west pillar in January 1943; and in three cases where geophones were near a point where a sill was taken out and where presumably the strain was great.

D. Extraneous Noises not a Serious Handicap:

The recorders are very sensitive, and noises of many kinds may be heard, and even registered, at considerable distances. This, however, is not a serious handicap, as man-made and machine noises are easily differentiated, either on the records or when heard; this is true also of rock runs and cave-ins.

The occasional snapping that occurs from time to time within a radius of, say, 1,000 ft. of a geophone will sometimes register and can generally be heard on geophones. But experience shows that snapping of this type never gives high counts and is far from being localized. It is tentatively assumed that until the count is both high and localized it may be disregarded from the standpoint of the existence of strain foci, at least within the range of the geophones. There is much evidence favouring this assumption, and none to the contrary.

E. Routine Counts May Have Value

It is assumed that much of the general snapping is due to the movement of blocks of ground of various sizes, and that the continuance of such snapping is, if anything, a sign that localized pressure is not developing. There is some indication that simultaneous snapping decreases as localized snapping develops.

It is felt that, however laborious it may be, tabulations of all counts and study of their simultaneity from day to day should be carried on until a completely satisfactory record of a burst or bursts has been secured.

F. Geologic Structure Affects Counts

It is proposed to examine the geologic structure by means of a portable tapper, as it has been shown by the records that it does affect the counts. Experience indicates that structure has a marked effect in some cases and not in others.

As an example of the former, it may be noted that H46 is in 4701E-4 and H40 in 4701E-3. Each hole is 30 ft. deep and in the south wall of the drift. The distance between is 135 ft. In November 1943, H46 had high counts and H40 low. Now H40 has high counts and

H46 low, in spite of the fact that H46 is much nearer to a working stope than is H40. It would be most instructive to have a series of 30-ft. holes, drilled about 30 ft. apart, from a point about 30 ft. west of H40 to a point about 30 ft. east of H46. Then a study could be made, using the portable listening equipment, at this series of holes, when the regular records showed a marked difference in the counts from the two holes.

As a further example of a hole which seems isolated, one might cite H34 (4702E-6), which sometimes develops both local and general snapping that does not register well on other geophones.

To sum up: If and when geologic structure seems to be interfering with the counts, experiments should be conducted with the tapper and by drilling to determine where the geophone (s) should be installed to protect any given stope.

G. Evidence for Prediction Lacking.

In the west pillar, localized snapping registered in increasingly higher counts for some days prior to the burst of January 29, 1943. But on the east side, to date, there has not been a single case of a burst occurring where a geophone was within 75 to 100 ft. and where listening or recording was going on prior to the burst.

Furthermore, the most that can be determined by this method, even if it proves as successful as can reasonably be expected, is that it will indicate points of critical pressure. The factors which combine to cause a burst are so many and so unknown that all one could reasonably say is that a danger point exists if the count becomes localized and active. Long experience with properly placed equipment might help to segregate the acutely critical from the critical cases. Certainly, the contribution of experienced miners must carry much weight in deciding how a focus of critical strain should be treated. The method can only state that such a focus exists and indicate when it ceases to be critical.

H. Qualifications for Listening:

It is the considered and firm opinion of the writer that the problems raised with regard to the possible need for peculiar listening powers in observers need not be a source of great concern. The questions have suggested a special type of filter which, if successful, will be extremely useful in deciding whether the localized snapping goes up at a higher rate than the general type and will permit an analysis of the spectrum of frequencies to find out what range is the most informative for listening as well as recording. But, even if fully successful, the counts can only tell where the critical points are, not whether a burst will occur.

Experience shows that, when the counts are high, there is always a large percentage of localized snaps, i.e. very high counts are never wholly general. All counts may rise in a certain section of the mine, but only the point of critical strain will show very high counts.

Two men, equipped respectively with the present type instrument and with the hypothetical filter design, under the same circumstances, would bring back the same reports of critical conditions which might or might not result in a burst. But, if such points are systematically detected and are studied as to their history under various circumstances by both miners and geophysicists, experience should, in time, permit some graduation in estimating the degree of menace to be assigned to any newly detected focal point. The only qualifications a listener must have, so far as the frequency question is concerned, are good hearing and persistent patience.

M-7 Rockbursts Located, April 1943 to January 1944

| | Date | No. | Time | Class | Location | Rock Displac't |
|---|---------|------|------------|-------|-----------------------|----------------------|
| A | Apr. 7 | 345S | 3:55 p.m. | - | 4402E-5 to 4502E-5 | small |
| B | " 9 | 297C | 7:05 p.m. | heavy | 4450E to 4825E | several hundred tons |
| C | June 2 | 346S | 2:45 p.m. | - | 4802E-3 | 25 tons |
| D | July 13 | 298C | 2:30 p.m. | light | 4902E-2 | 30 tons |
| E | Aug. 18 | 299C | 2:30 p.m. | light | 4801E-5 | several tons |
| F | Sep. 29 | 300C | 1:19 a.m. | med'm | 1801W-11 | 50 tons |
| G | Oct. 5 | 301C | 2:32 p.m. | med'm | 4701E-4 to 4801E-4 | 160 tons |
| H | " 15 | 302C | 5:45 p.m. | light | 3 shft. plr. | 10 tons |
| I | " 26 | 303C | 12:20 p.m. | heavy | 3 shft. plr. | over 1,000 tons |
| J | " 29 | 304C | 3:00 p.m. | light | 4701E-6 | several tons |
| K | Dec. 13 | 305C | 3:20 p.m. | med'm | 4801E-7 | 100 tons |
| L | " 18 | 306C | 3:30 p.m. | light | 4502E-5 | 25 tons |
| M | Jan. 5 | 347S | 3:30 p.m. | - | 4502E-5 | 25 tons |
| N | " 10 | 307C | 3:30 p.m. | light | 4501E-5 | several tons |

| | Date | No. | Time | Class | Location | Rock Displac't |
|---|------|------|-----------|-------|-----------------------|----------------|
| O | " 13 | 348S | 3:30 p.m. | - | 4502E-5 | 10 tons |
| P | " 20 | 308C | 4:35 p.m. | med'm | 3501E-5 to 3811E-5 | sev.hun. tons |
| Q | " 28 | 349S | 3:30 p.m. | - | 4801E-7 | 15 tons |

The above list shows only the burst that occurred during the period indicated and that were located and investigated in Lake Shore Mines. More than 120 bursts were of sufficient magnitude to register on the seismographs. Some serious interruptions to the recorder on the 3075-ft. level in January 1944 leave in doubt the exact number of bursts that might have registered. Seventeen bursts (5 strain, 12 crush) were surveyed and reported as above shown. All but four (B, F, H, I,) occurred during or close to the afternoon blasting in the off-shift period. All but four (E, H, I, P,) occurred in the section of the mine directly under investigation (east side, 4325-ft. level to the 4950-ft. level). The second burst (Oct. 26) in No. 3 shaft pillar (I) registered on the seismograph at Ottawa.

Of the unlocated bursts (more than 120 in that time), it is known from record indications that most of them occurred in the block of ground under investigation. Listening experience shows that this section of the mine is the most consistently active. It appears from the experience so far gained that the 4700-ft. level is the best rockburst laboratory available in the mine at this time. There seems to be no reason to regret the choice of locale or to wish for a more promising place to study. It has become necessary to recognise the fact of slip bursts and to direct every effort to solve the special problems connected with this type of disturbance.

*

Report N

This report was a bibliography which, in the present publication is somewhat amplified and relegated to an Appendix.

*

Report O

February 1944 -- June 1945

.

There was a large measure of continuity during the period in the underground program, along the lines described in Report M. The writer continued in charge of this work, ably assisted by Hallick, to whom is due much credit for keeping the investigation going efficiently. Mrs. Grace resigned in November 1944, and was replaced by Miss Mary Hallick, who proved a most capable and devoted assistant.

O-1 Recording Program

As of January 31, 1944, the recording program on the east side of the mine, from the 4450-ft. level to the 4825-ft. level, was well established. From time to time since, geophones have deteriorated and had to be changed. In some cases, where a hole had been partly closed by slips along fault planes, the defective geophone has had to be abandoned. When this occurred, the hole was re-drilled and incorporated into the program as soon as possible. A tabulation of the holes and their locations is given in section O-6.

Interruptions occurred occasionally when lines were damaged by mining operations. In general, such breaks were of short duration. Somewhat longer lapses resulted from extensive timbering or mining operations involving drifts in which cable lines were strung. The most important of these was in 4802E, where a considerable amount of re-timbering was done in December 1944 and the first two or three months of 1945. Another important interruption held up the holes in 4701E (except H40 and H55) during the latter part of April and early part of June 1945. Some reduction in coverage also resulted when recorders were brought to surface for repairs. One fairly long break occurred during October and November, when recorder 4 was on surface for about six weeks for use in developing a high-speed chronograph.

All available recorder channels were used every day. When the usual holes were not in operation, others were put on the recording program for the time being. When there was a shortage of recorders, the holes in good order were serviced each day on the listening program.

An outline of the recording maintained appears in section O-7. It is to be noted that all possible coverage was maintained during the entire period. From July 1, 1942 to the end of June 1945, about 2700 records were made. Most of these were about 40 ft. long; many were considerably longer. All were carefully studied and their data were entered daily into the tabulations and graphs.

O-2 Listening Program

Experience gained prior to the period covered by this report showed that listening is best carried on during the early morning, off-shift hours. Every hole available, whether in the recording program or not, was included in the listening program every day except Sundays, up to the end of February 1945, when some omissions were unavoidable.

The writer spent more than half his time at Kirkland Lake, going underground each day at 3 a.m. and remaining until the day shift began (8 a.m. during the winter months and 7 a.m. in the summer).

In November 1944, some difficulty was experienced in making clear just what degree of seismicity the operator felt should be assigned to each hole each day. The count alone was not a sufficient index, since the 'normal' count on some holes was much higher than on others. Several tentative drafts of a scheme for describing the seismicity were tested for some weeks by both operators, each independently assigning a 'seismicity factor' to his listening at each hole. After several amended drafts had been tried out, a scale called a 'Seismicity Factor on a Scale of Ten' was drawn up. This was found to work out satisfactorily and was adopted as standard practice.

The factor gives considerable satisfaction to each of the operators as a reasonable statement of his estimate of the seismicity of each hole each day. It is seldom that Hodgson and Hallick differ by even one point, in listening to a group of 30 to 38 holes each morning.

O-3 Seismicity Factor on a Scale of Ten

The seismicity factor or index of critical conditions is an attempt to permit a daily plotting of underground data as they appear to the operator. Subject to change as the idea is worked out, the following significance is to be given the factor by operator and management:

0. Trace only.
1. Definitely subnormal for the hole concerned
2. Low normal activity
3. Count about normal, but no definite D or L indication (see below)
4. Normal activity for the hole concerned; some D or L; no trace of 'viciousness' in the sound of the snaps
5. High normal for the hole; trace of viciousness or moderately high D-count; not markedly sporadic; no salvoes
6. Higher than normal; high D with definite viciousness, sporadic occurrence, or salvoes
7. Vicious local snaps; counts at least twice normal; possible sporadic with salvoes or with D-type snaps too high to count accurately
8. Counts definitely high; at least four times normal for hole concerned; vicious local snaps or salvoes

9. High vicious local snaps that can be counted; association with any particular stope uncertain or leaving some doubt with the operator as to immediate critical conditions
10. Very high vicious local snaps, near or above possibility of counting, definitely identified with a given stope or stopes; no doubt in operator's mind that work should be suspended.

The letter D or the letter L will follow the factor number, meaning distant or local. The former indicates that the conditions reported was not exactly at the hole but that it was determined from the distant-local snapping heard there. The letter L indicates that the condition reported was based on local-type snapping and that the pressure locus is close to the hole indicated.

For the special attention of shift bosses the following simplification indicates the nature of the report and is indicative of the attention required:

- 0 to 5 No special attention, unless it shows change since the previous day's report
- 5 to 6 Activity just becoming worthy of notice by those in charge underground
- 6 to 7 Shift boss or captain should examine ground reported
 - 8 Condition definitely acute, but not critical; examination should not be neglected
 - 9 Conditions critical, but there may be explanatory circumstances (heavy blast, still removed, etc); operator could possibly concur in decision to continue work
10. Conditions definitely critical in operator's opinion

O-4 Rockbursts Experienced

In the following section a list is given of the 34 rockbursts that occurred at Lake Shore during the period covered by this report, and that were located and reported on by the engineering staff. An analysis shows that only three of these occurred in time and place that might have resulted in their being predicted: in each case, the burst occurred some hours after the listening and recording had ceased.

Two of the bursts were quite small, as evidenced by the reports; the third displaced about 100 tons and was classed by the engineers as a 'light crush burst'. There was some measure of prediction for this burst, definitely from one hole and generally from the holes in section 6, which were reported as showing signs of strong seismic activity. It occurred more than four hours after the listening and recording had ended.

It must be concluded, that the rockburst activity was low on account of the reduced mining schedule -- too low to afford the necessary experience in the ground under survey.

However, the bursts that were located and surveyed were not the only ones that occurred at Lake Shore. There were several hundred during the seventeen months covered by this report. These were small bursts, bursts occurring in unused workings, or bursts too far in the wall to throw down loose. Such bursts occurred frequently with the blasting, and sometimes also in off-shift periods.

O-5 Rockbursts Located, February 1944 to June 1945

| | Date | No. | Time | Class | Location | Rock Displac't | |
|---|------|-----|------|-------------|----------|-------------------------------|------------------------------|
| A | Feb. | 9 | 350S | 3:15 p.m. | - | 4901E-6 | 42 tons |
| B | " | 15 | 309C | 3:32 a.m. | light | 4704XC 4801E-5 4801E-Dr | 5 tons 25 tons 40 tons |
| C | Mar. | 11 | 351S | 3:30 p.m. | - | 4801E-7 | 15 tons |
| D | " | 14 | 352S | 3:03 p.m. | - | 4902E-Dr at XC | total of 28 tons |
| E | Apr. | 6 | 353S | 3:33 p.m. | - | 4502E-5.3 | 4 tons |
| F | " | 18 | 354S | 10: a.m. | - | 4501E-5.3 | small amount |
| G | " | 20 | 355S | 7:15 p.m. | - | 5001E-Dr | 15 tons |
| H | " | 22 | 356S | 3:30 p.m. | - | 4801E-7 | 5 tons |
| I | " | 29 | 357S | 3:35 p.m. | - | 4401E-6 | 10 tons |
| J | May | 8 | 310C | 3:45 p.m. | med'm | 3209E-Dr 3202E-Dr | 90 tons 30 tons |
| K | " | 19 | 358S | 10:05 a.m. | - | 4501W-8.1 | 1 ton |
| L | June | 1 | 359S | bet. shfts. | - | 4701E-6 | 10 tons |
| M | " | 2 | 360S | 2:35 p.m. | - | 4502E-5.3 | 2 tons |
| N | " | 19 | 311C | 11:01 a.m. | light | 4701E-Dr 4801E-7 | total of 100 tons |
| O | " | 24 | 361S | 2:35 p.m. | - | 4501E-Dr | 25 tons |

DOMINION OBSERVATORY

| | Date | No. | Time | Class | Location | Rock Displac't |
|---|---------|------|-------------|-------|----------------------------------|-------------------------------|
| P | Aug. 12 | 312C | 11:08 a.m. | med'm | 4001W-Dr 4201W-Dr 4201W-11 | 50 tons 25 tons 75 tons |
| Q | " 15 | 362S | 2:35 p.m. | - | 4501E-5.3 | 2 tons |
| R | " 29 | 363S | 2:30 p.m. | - | 4401E-6 | 10 tons |
| S | Sep. 6 | 313C | 2:55 p.m. | med'm | 4401E-Dr 4501E-Dr 4701E-Dr | 5 tons 50 tons 5 tons |
| T | Oct. 5 | 364S | 2:35 p.m. | - | 4401E-6 4401E-Dr 4301E-Dr | all three small |
| U | " 25 | 314C | 5:30 p.m. | med'm | 4801E-Dr 4901E-Dr | 100 tons 120 tons |
| V | Jan. 15 | 365S | bet. shfts. | - | 4802E-Dr | 10 tons |
| W | " 22 | 366S | 9:30 a.m. | - | 4701E-Dr | 2 tons |
| X | Jan. 27 | 315C | 2:50 p.m. | light | 4301W-Dr 4408W-Dr | 25 tons 5 tons |
| Y | Feb. 15 | 367S | 3:33 p.m. | - | 4901E-6.2 | 55 tons |
| Z | " 21 | 368S | bet. shfts. | - | 5001W-Dr | 30 tons |
| a | Apr. 9 | 369S | 8:10 a.m. | - | 4901W-9 | 2 tons |
| b | " 17 | 316C | 2:05 p.m. | light | 4001W-15 | 80 tons |
| c | " 20 | 370S | 1:50 a.m. | - | No. 4 shft 4825' + | 25 pounds of concrete |
| d | May 22 | 317C | 2:35 p.m. | med'm | 4002E-Dr 4202E-Dr | 50 tons 100 tons |

| | Date | No. | Time | Class | Location | Rock Displac't | |
|---|------|-----|------|-----------|----------|--|---|
| e | " | 26 | 318C | 2:40 p.m. | light | 3001W-Dr 3201W-1 3051XC 3075XC No. 1 shift | total given as much loose shaken down |
| f | " | 28 | 319C | 9:45 p.m. | med'm | 4901E-Dr 4901E-6.3 | 250 tons cannot estimate |
| g | June | 4 | 371S | 9:10 a.m. | - | 4301XC No. 1 shift | about 3 tons |
| h | " | 26 | 320C | 1:15 p.m. | light | 5001W-8 | 70 tons |

The above list shows only the burst that occurred during the period indicated and that were located and investigated at Lake Shore. The seismograms indicated many more small strain bursts, nearly all of which occurred with the blasting. Twelve of the bursts were identified as crush type and 22 as strain. The crush bursts were either light or medium; none were heavy.

The time of occurrence was associated with blasting on 18 occasions, 3 were 'between shifts' and 6 others were reported at times which were on the night off-shift. The remaining 7 occurred between 8 a.m. and 10 a.m. These are the ones that might have been detected by the microseismic service. They are listed as: F, K, N, P, W, a, g.

Of these, K, P, a, and g were located so far out of the territory under study that microseismims could not have been picked up from them. We may refer to the listening data for the other three: F, N, and W.

Burst F: April 18, 1944, No. 354S, 10 a.m., 4501E-5:3, 'small rock displacement'. Listening report No. 414 shows full-time listening on April 18 from 6:08 a.m. to 7:08 a.m. There was a moderately high count (20+) on H49 in 4401E6, showing D-type snaps. This hole is just above the burst. H50, just below it, had a count of 10+, a rather high value for this hole, which has shown a consistently low count; the activity here, moreover, included L-type snaps. On the whole, there was very little indication that a burst was imminent: it would certainly not have been predicted. It must be noted, however, that H50 is definitely in a non-sensitive location. The rockburst report shows that only a small amount of muck

was blown off the north wall of stope 4501E5:3 at a point about half-way between 4450-ft. and 4575-ft. levels. This was definitely a minor disturbance.

Burst N: June 19, 1944, No. 311C, 11:01 a.m., 4701E-Dr and 4801E-7, total of 100 tons. Listening report No. 467 shows full-time listening on June 19, from 6:08 a.m. to 6:57 a.m.. The rockburst report shows that stope 4801E-7 had its south wall shattered from the 4700-ft. to the 4825-ft. levels, at section 7. Much loose was shaken down on 4701E-Dr also, above this stope. The holes nearest to this burst were: H55 in 4704XC, H51 in 4701E, and H53 in 4801E. There was a high count (20+) from H55, with L-type snaps included, and the operator notes: 'A large amount of distortion was recorded on all the records, but it registers more from the holes in section 6. Interference seems to be seismic'. H51 showed a count of 0+, the snaps being of the general type only. H53 is given exactly the same rating as H51. Except for the general interference mentioned by the operator and the high count on H55, there was no indication of this burst on the nearby geophones, some five hours before the burst. This is, of course, quite a long time, but there was no blasting in the meantime, or at the time of the burst. Fortunately, it occurred at lunch time, so no one was injured.

Burst W: Jan. 22, 1945, No. 366S, 9:30 a.m., 4701E-Dr., 2 tons. Listening report No. 649 shows full-time listening on Jan. 22, from 3:47 a.m. to 5:11 a.m. The comment is 'None very active'. The rockburst report shows that about two tons of rock was shaken off the drift wall at about section 4. The hole nearest to this burst is H40, or H56. H40 showed a count of 0+, the snaps being all G-type. The seismicity factor (adopted prior to the time of this burst) was given as 1D, about the lowest that can be assigned. The operator notes that: 'H40 does not pick up the tapper', indicating that the geophone there had deteriorated to a very low efficiency. H56, however, had a count of 20- and a factor of 4D.

Thus, after almost a year and a half of study by means of the subaudible method, during which every effort was made to have as complete coverage as possible of the territory assigned, only three bursts occurred in circumstances that afforded any chance of prediction. Of these, one (F) was very small. Another (W) was also small (2 tons displacement). The third (N) was of considerable magnitude — 100 tons — and even this was classed as 'light' in the rockburst report made by the mine engineers. Furthermore, it occurred some four hours after listening. For this there was some fair measure of prediction from H55, and the operator's comment of considerable interference in section 6, which he stated 'seems to be seismic'.

The conclusion seems to be that the rockburst activity was too low, on account of the reduced mining schedule under wartime conditions, to afford the necessary experience in the block of ground under survey.

O-6 Test Holes, Nos. 55-107

| H | DD | Date | Location and Wall | Depth | Remarks | |
|-----|------|------------|-------------------|--------|-------------------------------|---|
| 55 | 4038 | Mar. 23'44 | 4704XC-E | 53' | Drilled diagonally E40°S | A |
| 56 | 2959 | Mar. 23'44 | 4701E-4-S | 72'+ | Old DD hole | B |
| 57 | | May 26'44 | 4702E-2-N | 4'+ | Bootleg to check 4702E-2-N | |
| 58 | 4083 | Aug. 7'44 | 4702E-2-N | 56' | Special diagonal hole | C |
| 59 | 4084 | Aug. 9'44 | 4702E-4-S | 30'3" | Replacing H39 | D |
| 60 | 4055 | Aug. 16'44 | 4401E-6-S | 30' | Replacing H49 | E |
| 61 | | Sep. 9'44 | 4502E-2-S | 4'+ | Bootleg replacing H43 | |
| 62 | 4112 | Oct. 27'44 | 4502E-3-S | 30'4" | Replacing H43 and H61 | F |
| 63 | 4111 | Oct. 27'44 | 4502E-6-S | 31'9" | Replacing H48 | G |
| 64 | 4124 | Nov. 29'44 | 4802E-3-S | 29'10" | Replacing H41 | H |
| 64A | | Dec. 21'44 | 4802E-0-N | 4'- | Replacing H64 | I |
| 65 | ? | Feb. 9'45 | 4701E-6-S | 30' | Replacing H51 | J |
| 66 | | Dec. 15'44 | 4701W-1-N | 4'+ | Bootleg | K |
| 67 | ? | " | 4701W-1-N | 30'+ | Old DD hole | K |
| 68 | | " | 4701W-2-N | 4'+ | Bootleg | K |
| 69 | | " | 4701W-2-N | 4'+ | Bootleg | K |
| 70 | | " | 4702E-2-S | 4'6" | NP - 4700 | M |
| 71 | | " | 4702E-2-N | " | " | M |
| 72 | | " | 4702E-2-S | " | " | M |

DOMINION OBSERVATORY

| H | DD | Date | Location and Wall | Depth | Remarks | |
|----|----|-----------|-------------------|-------|------------|---|
| 73 | | " | 4702E-2-N | " | " | M |
| 74 | | " | 4702E-2-S | " | " | M |
| 75 | | " | 4702E-3-N | " | " | M |
| 76 | | " | 4702E-3-S | " | " | M |
| 77 | | " | 4702E-3-N | " | " | M |
| 78 | | " | 4702E-3-S | " | " | M |
| 79 | | " | 4702E-3-N | " | " | M |
| 80 | | " | 4702E-3-S | " | " | M |
| 81 | | " | 4702E-4-N | " | " | M |
| 82 | | " | 4702E-4-S | " | " | M |
| 83 | | " | 4702E-4-N | " | " | M |
| 84 | | " | 4702E-4-S | " | " | M |
| 85 | | " | 4702E-4-N | " | " | M |
| 86 | | " | 4702E-4-S | " | " | M |
| 87 | | " | 4701W-1-S | " | Bootleg. | L |
| 88 | | " | 4701W-1-S | " | " | L |
| 89 | | " | 4702W-1-S | " | " | L |
| 90 | | Feb. 1'45 | 4802E-2-S | " | NP -- 4800 | M |
| 91 | | " | 4802E-2-N | " | " | M |
| 92 | | " | 4802E-2-S | " | " | M |
| 93 | | " | 4802E-2-N | " | " | M |

| H | DD | Date | Location and Wall | Depth | Remarks | |
|-----|----|-----------|-------------------|-------|-----------|---|
| 94 | | Feb. 1'45 | 4802E-2-S | 4'6" | NP - 4800 | M |
| 95 | | " | 4802E-3-N | " | " | M |
| 96 | | " | 4802E-3-S | " | " | M |
| 97 | | " | 4802E-3-N | " | " | M |
| 98 | | " | 4802E-3-S | " | " | M |
| 99 | | " | 4802E-3-N | " | " | M |
| 100 | | " | 4802E-3-S | " | " | M |
| 101 | | " | 4802E-4-N | " | " | M |
| 102 | | " | 4802E-4-S | " | " | M |
| 103 | | " | 4802E-4-N | " | " | M |
| 104 | | " | 4802E-4-S | " | " | M |
| 105 | | " | 4802E-4-N | " | " | M |
| 106 | | " | 4802E-4-S | " | " | M |
| 107 | | Feb. 9'45 | 4704XC-E | 50' | | N |

- A Log H55 0'-28' Badly broken and shattered porphyry; much lost core; 24 pulls; several weak seams, some stronger ones at 19', 38', and 27'
- 28'-53' Porphyry, less broken and shattered; 10 pulls; possible seams at 31', 38', and 45', no casing.
- B H56 is an old DD hole in very good condition; canted slightly upward from the collar; cleaned out to a depth of 72' on or about March 23'44; extends to a much greater depth.
- C H58 is a specially drilled DD hole running diagonally NW from a collar on the north wall of 4702E2; cuts diagonally behind the anvil of the tapper; emerges in 4700 main crosscut; hole cased at both ends to a depth of about 6'; core shows porphyry; small slips at 12' and 45'10".

- D Log H59 0'-30'3" Badly broken up 50 per cent lost core; weak fractures at 19.5', 23', and 26.5'; no sludge return.
- E H60 is a DD hole run for sampling but taken over to replace H49, which was lost by closure; cants downward from the collar at about 19°.
- F Log H62 0'-19' Core slightly broken; good recovery; 7 pulls.
19'-30'4" Good solid rock.
- G Log H63 0'-7'4" Very badly crushed porphyry; much lost core; 8 pulls; calcite seam 7'4".
7'4"-23' Not so badly broken; 11 pulls; strong break 16'-18'.
23'-31'9" Good ground; good ore recovery.
- H Log H64 0'-29'10" Very badly broken all the way; 23 pulls; core losses up to 10" in places.
- I H64A is a bootleg in 4802E near the main cross-cut and in the north wall.
- J H65 was drilled in 4701E-6-S to replace H51, which had been lost owing to closure.
- K H66, H67, H68, and H69 are holes, in order going west, in the north wall in 4701W1 to 4701W2. H67 is an old DD hole in good condition. It is over 30' deep, for a geophone was located in it at that depth. The others are old PD holes, shallow, but clean and in good condition.
- L H87, H88, and H89 are old PD test holes, in order going west, in the south wall in 4701W1 to 4701W2. They are shallow, but clean and in good condition.
- M Holes 70-86 were drilled in 4702E, the even-numbered holes in the south (hanging) wall, the odd-numbered holes in the north (foot) wall. H70 is 50' east of the main cross-cut and the successive even-numbered holes are at 30' intervals to H86. H71 is 65' east of the main cross-cut and the successive odd-numbered holes are at 30' intervals to H85. Holes 90-106 were drilled in 4802E, the even-numbered holes in the south wall, the odd-numbered holes in the north wall. H90 is 50' east of the main cross-cut and successive even-numbered holes are at 30' intervals to H106. H91 is 65' east of the main cross-cut and the successive odd-numbered holes are at 30' intervals to H105. All the holes 70-106 are PD type, as deep as they could be drilled in what was often very poor wall. The effective depths vary from 4' or less to about 6'. All were drilled for use in the Intensive Seismic Program (NP).
- N H107 was drilled paralalled to H55, which was lost owing to slippage along a diagonally crossing fault plane.

O-7 Recording from Holes 36-107, February '44 to June '45

The following table shows the number of days of recording from holes 36 to 107 for the period. In the original report, these data were recorded to show the particular days when each hole was employed during that time. In addition, a series of notes (43 in all) explained the lapses in operation for the various holes concerned.

It does not seem worth while to report the data so fully in the present publication. The information given serves to show the extent and continuity of the operation for the seven-teen months concerned.

DOMINION OBSERVATORY

| | H | F | M | A | M | J | J | A | S | O | N | D | J | F | M | A | M | J | T |
|-----|-----|-----|-----|-----|-----|-----|-----|-----|-----|-----|-----|-----|-----|-----|-----|-----|-----|-----|-----|
| 56 | ... | ... | 10 | 25 | 26 | 31 | 31 | 30 | 31 | 30 | 31 | 31 | 28 | 31 | 19 | ... | 16 | 370 | |
| 57 | ... | ... | ... | ... | 27 | 31 | ... | ... | ... | ... | ... | ... | ... | ... | ... | ... | ... | 58 | |
| 58 | ... | ... | ... | ... | ... | ... | 27 | 3 | 10 | ... | ... | ... | ... | ... | ... | ... | ... | 40 | |
| 59 | ... | ... | ... | ... | ... | ... | 15 | 30 | 21 | 30 | 31 | 31 | 28 | 28 | 30 | 28 | 18 | 290 | |
| 60 | ... | ... | ... | ... | ... | ... | 14 | 30 | 31 | 30 | 31 | 18 | ... | ... | ... | ... | ... | 154 | |
| 61 | ... | ... | ... | ... | ... | ... | ... | 24 | 31 | 2 | ... | ... | ... | ... | ... | ... | ... | 57 | |
| 62 | ... | ... | ... | ... | ... | ... | ... | ... | ... | 23 | 31 | 31 | 28 | 31 | 28 | 31 | 18 | 221 | |
| 63 | ... | ... | ... | ... | ... | ... | ... | ... | ... | 23 | 31 | 31 | 28 | 31 | 28 | 31 | 18 | 221 | |
| 64 | ... | ... | ... | ... | ... | ... | ... | ... | ... | ... | 19 | 15 | 28 | 31 | 21 | ... | ... | 114 | |
| 64A | ... | ... | ... | ... | ... | ... | ... | ... | ... | ... | 12 | 16 | ... | ... | ... | 31 | 18 | 77 | |
| 65 | ... | ... | ... | ... | ... | ... | ... | ... | ... | ... | ... | ... | 17 | 23 | 19 | ... | 8 | 67 | |
| 96 | ... | ... | ... | ... | ... | ... | ... | ... | ... | ... | ... | ... | 10 | 24 | ... | ... | ... | 34 | |
| 107 | ... | ... | ... | ... | ... | ... | ... | ... | ... | ... | ... | ... | 2 | ... | 11 | 31 | 10 | 54 | |
| NP | ... | ... | ... | ... | ... | ... | ... | ... | ... | ... | ... | ... | ..8 | 28 | 31 | 30 | 31 | 25 | 153 |

Note: At the time Report O was written, the April recording was in hand to April 18, only except for some NP values included in that line for the last entry.

O-8 Intensive Seismic Program

Experience at Lake Shore with the subaudible method showed that the geophones pick up the microseismims, and that the Obert recorders register them, at a rate varying with time and, for identical times, with place. Experiments by Obert at the Bureau of Mines, College Park, Md., have shown that pressure alone, without resulting cracking or change in strength, is the cause of microseismims.

Small samples of solid rock were cut into symmetrical blocks about 4"x2"x2", having plane-parallel faces, top and bottom. Holes were drilled in the blocks to accommodate

regular Obert geophones. The blocks, carrying geophones connected to Obert recorders, were placed in a special hydraulic press, designed to hold high pressures with negligible loss, without keeping the pump running. The pressure was raised level by level, in steps usually of 2,000 lb./sq. in. to the point of failure of the specimen, a count being made, for five minutes at each level, of the number of microseismims heard through the headphones and recorded on the Teledeltos paper. It was definitely shown that:

Microseismims are generated by pressure even where there is no apparent failure of the rock.

The number of microseismims per minute (C/M) rises markedly at about 80 per cent of the bursting strength and continues to increase up to the point of failure.

The data from these experiments were made available to the writer at a conference arranged by Obert at Ishpeming, Mich., Oct. 27-29, 1944. The experiments were reported to the Department and to Lake Shore, and it was decided as a result to undertake a long-term experiment, with closely spaced holes, using as many geophones as possible, in a section of the mine known to be unstable. This was designated the Intensive Seismic Program.

The idea was to select a small two-level region of the mine, known to be unstable, to drill a large number of holes at 30-ft. intervals and to arrange to record daily throughout both off-shift periods from any nine holes on each level, using the stepping switches to yield a defined schedule of eleven recordings of equal length per hour for three hours in each period. This would yield, from the two levels, a 45-ft. strip of dual recording, showing records from eighteen different holes, with one hole on each level recording three times per hour as a check. Finally it was planned to mount each day's record on a specially designed board and to photograph it on an 8"x10" negative, making one print for the Mine and one for the Observatory. These prints were to be analysed in a brief monthly report, indicating the outstanding features.

It was hoped in this way to be able to select the eight holes on each level that could be shown by test to be in solid ground, yielding microseismim records, and to be sure, in the event of a burst in the region selected, of getting at least some record sections within the distance required to get a recording of the microseismim increase preceding the burst.

It seemed increasingly certain that the method, if it was to provide effective protection for the miners, would have to be carried on as a listening program conducted by competent operators serving the working stopes during shift hours. It was hoped that, by means of the new program, a very decisive proof would be forthcoming that the method would be effective:

A sample record appears as Figure 77. A printed explanation of the set-up, applicable to every day, appears on the left-hand side, as it does on every photograph. The

explanation is thus immediately available whenever any record is being examined. The long-hand entries on the right hand side of the photograph are peculiar to that set of recording alone.

RESEARCH DATA FILES

The initial arrangements made between the Observatory and Lake Shore Mines provided that the surface seismograph records should become the property of the Observatory, and that all other data should be turned over to the Mine. In accordance with this agreement, and through a further arrangement at the time the research was terminated, all the Mine data were taken to Ottawa to be put in order for filing and reference. All the research data, except the records of the surface seismograph, were completed and finally delivered to Lake Shore Mines.

*

STUDIES OF SEISMIC WAVE PROPAGATION FROM ROCKBURSTS

The perfecting of time-distance curves for short epicentral distance has always been a difficult problem where earthquakes are used as the energy source. It is never possible to determine with accuracy the exact time of an earthquake or its epicentre and depth of focus. In the case of short-distance tables, this uncertainty is serious. Furthermore, any such tables prepared for a given part of the earth are not likely to be universally applicable.

Experiments utilizing explosions as the source had been carried out by a number of investigators in various regions. This procedure has the advantage that the operator knows for each explosion not only its exact position, but also the exact time of the blast, thus permitting the use of sensitive seismographs with an open time scale. The results obtained differed from the generally accepted tables for nearby earthquakes by amounts greater than the errors of observation for the blast studies. It was thought that these differences were perhaps due, in part at least, to the difference in the nature of blasts and earthquakes.

Rockbursts, which are in effect miniature earthquakes, could, at least for those occurring in the Kirkland Lake area, be located precisely in depth as well as laterally. With an accurately controlled seismograph at that place, they could be timed very closely to the nearest second or better. If time-distance tables could be obtained for the traverse from Kirkland Lake to Ottawa, they would be of particular interest and value, since they would apply to the structure in and below the Canadian Shield. The studies outlined in Report H had

shown that for the larger bursts good records could be obtained on the Benioff vertical at Ottawa and even on the Wood-Anderson at Seven Falls, Que.

It was decided to undertake a major research program, extending over several years, to determine travel times from the Kirkland Lake rockbursts. A modern seismograph vault was constructed on Hallick's property, in the town but away from the heavy traffic. Three-component Benioff seismographs, together with the requisite time-keeping and radio equipment, were installed. Hallick was placed in charge of the station, operating it in his spare time. A vault on solid rock was possible, as the soil was only from three to four feet deep; it is shown in Figure 81. Experience over the years (the station is still in operation in 1957, as part of the Canadian seismological service) has shown that highly sensitive seismographs can operate in this semi-underground vault without appreciable disturbance. The traverse from Kirkland Lake to Ottawa, with available roads indicated, is shown in Figure 78. Figure 79 shows an excellent record of a rockburst by a Benioff vertical seismograph at the Dominion Observatory: this burst occurred in a mine near Lyon Mountain, N.Y., 102 miles away.

According to the plan, temporary seismograph stations were to be established as nearly as possible along the line of the traverse and at ever-increasing distances from Kirkland Lake. Bases were to be cast in cement on bald rock outcrops in locations as far as possible from local disturbance. The project was begun in the spring of 1946, the first station being established at Dane, Ont., about 5 miles from Kirkland Lake.

A pre-fabricated movable hut was used to protect the instruments. Timing was maintained by chronometers, checked at least once a day by radio signals. Where possible, Hydro power was used for driving the drums, etc. Where it was not available, storage batteries operating through 60-cycle alternators were used. A typical station lay-out is illustrated in Figure 80.

In practice, a station was operated until a well-timed and well-located rockburst in the Kirkland Lake area had given sufficient data for the distance involved. Excellent cooperation was received from the various mining companies in the Kirkland Lake camp. The distance values were determined with the help of the Geodetic Survey of Canada.

While waiting for a rockburst to record at the operating station, the next site was prepared. Moving to a new station usually took about twelve hours.

The project was placed under the immediate direction of John H. Hodgson. His studies appeared in a series of published papers, as listed in the bibliography at the end of this publication.

Report W

Laboratory Tests of Microseismic Method

for Detecting Critical Rock Pressures

by

Hodgson, Langford, and Bailey

The following report was prepared on the completion of a series of tests at College Park, Md., in February, 1947, with the collaboration of Dr. Obert and his associates at the U.S. Bureau of Mines. These experiments were similar to those previously reported in section O-8. The report was issued in mimeographed form for limited distribution only. It is included in the present publication to round out the evidence for and against the sub-audible method of detecting critical rock pressures.

W-1 Introduction

The microseismic (or subaudible) method of detecting critical rock pressures in mines subjected to rockbursts and rock falls was developed and applied in the United States by Leonard A. Obert, Senior Physicist, U.S. Bureau of Mines, Central Experimental Station, College Park, Md. He and his associates designed and built equipment for studying and recording the subaudible snapping, or 'microseismisms', assumed to be associated with rocks under pressures approaching their crushing strength. Publications reporting the progress of this work are listed, with Obert as senior author, in the bibliography (Appendix).

In Canada, a long series of research studies on rockbursts was conducted during 1939 to 1945 inclusive at the Lake Shore mine, Kirkland Lake, Ontario, under the direction of Ernest A. Hodgson, Chief, Division of Seismology, Dominion Observatory, Ottawa. These experiments were requested by Lake Shore Mines Limited and were carried out at the company's expense. For the last half of the period, the microseismic method was used exclusively, the equipment being furnished through the collaboration of the U.S. Bureau of Mines, together with some designed and assembled by the Canadian investigators, chiefly by Zack E. Gibbs.

During the seven years of the program, and especially during the last half of the time, much was learned regarding rockbursts — the rate of development of critical pressures, their migration in the mine, the distances over which microseismisms can be heard or recorded, the mechanism of bursts, etc. Full details of this work were reported in a series of mimeographed papers, which are presented here in condensed form.

It was concluded by the Canadian investigators that critical pressures can be detected in the mine by the microseismic method. In spite of the fact that the equipment is very

sensitive, and that mine noises, even in vacated workings during off-shift hours, are quite numerous, microseismims, indicating increasingly critical pressures, can be distinguished by several criteria, of which the two most important are:

- (a) They have a characteristic, high-pitched timbre, quite different from noises caused by falling rocks, distant drills, rock runs in ore passes, etc.
- (b) When the pressures are becoming critical, microseismims are very numerous (sometimes more than 100 per min. at Lake Shore) and these high rates of incidence persist for longer periods, sometimes hours or even days.

Thus, integrated mine noises caused by the casual fall of bits of rock in the workings never become sufficiently numerous to be confused with a warning run of microseismims. Furthermore, when noises do become numerous, as in a run of rock in an ore pass, the disturbance is easily distinguished from microseismims by the brevity of the run and by the difference in timbre of the sound as heard over the headphones.

It was not concluded that prediction of rockbursts can be made by this method, at any rate in the Lake Shore mine, since critical pressures migrate quite rapidly, sometimes within a few hours, in a block-faulted mine of this kind. It was believed, however, that even for such a mine a method could be worked out that would indicate whether or not a given stope was under critical pressure at any given time. It is still Hodgson's belief that this could be done. In large measure, this persisting belief arises from the experience gained during the hundreds of hours of study spent underground at Lake Shore Mines.

On the other hand, it must be admitted that, with one or two exceptions, no crudescence of microseismims observed at Lake Shore was followed by a rockburst. Nevertheless, positive failure of the method to detect critical pressures was never definitely shown. That is to say, no burst of any consequence occurred, except in conjunction with blasts, under conditions where prediction should have been made and was not.

Hence, the net result of the Canadian research seems to be that those operating the equipment underground believe that it can be perfected to a point where critical pressures can be detected at a given time and in a given place, but that prediction of bursts cannot be made, since critical pressures so often shift without a burst taking place. Others believe that microseismims, if they exist as such, cannot be distinguished from casual mine noise, and that a high rate of incidence of snaps, however caused, cannot be interpreted as an indication of dangerously critical pressure, much less as a prediction of rockbursts.

As part of the research carried out by Obert and his associates, prepared rock specimens were subjected to compression in a hydraulic press at sustained stages from low values up to crushing magnitudes, as reported in section O-8. The results obtained may be regarded as supporting the belief that the basic theory of the microseismic method is sound. If this basic principle be admitted, further research would seem to be warranted.

In view of the differences of opinion indicated in the second paragraph above, a request was made through the Associate Committee on Geophysics of the National Research Council of Canada that the latter sponsor further laboratory experiments along the lines of the preceding paragraph, the work to be done at the U.S. Bureau of Mines, Eastern Experimental Station, College Park, Md., under the direction of Dr. Obert and his associates, using typical specimens of rocks from Canadian mines. It was proposed that observers be sent from Canada, in the persons of a seismologist, an electronics engineer, and a mining engineer. These suggestions were approved and arrangements were made through the President of the National Research Council of Canada with the Director of the U.S. Bureau of Mines. The three men appointed were: Ernest A. Hodgson, Seismologist, Dominion Observatory, Ottawa; George B. Langford, Professor of Mining Geology, University of Toronto; and Ralph Bailey, Physicist, of the National Research Council.

Samples of rock were secured from Little Long Lac mine, Geraldton, Lake Shore mine, Kirkland Lake, International Nickel Company, Copper Cliff, all in Ontario; Central Cadillac mine, Cadillac, and Sigma mine, Bourlamaque, in Quebec. Unfortunately, the samples from Little Long Lac were lost in transit, and were not found in time to be used in the experiments. Section W-8 gives the information supplied by each mine regarding its samples, together with the identification number assigned in each case by the Bureau of Mines, as BM-488, where 488.1, 488.2, 488.3 indicate the three experimental cylinders cut from the same sample. These cylinders are 1 5/8 inches in diameter and 3 1/4 inches in length. They are designated "Type 2D" since the length is twice the diameter. The area of the end of the cylinder is approximately 2 square inches. The samples supplied by the mines met the indicated specification that they were to be of a size and shape 'which will permit cutting a 6-in. cube, free from flaws, from each sample'.

The experimental cylinders were prepared at College Park early in January 1947, and thin sections were prepared and sent to a Bureau of Mines petrographer for study and report. The experiments were scheduled to be run Saturday and Sunday, February 1-2, and Saturday and Sunday, February 8-9, as only at these periods could the building be completely vacated. The work was carried through as planned.

W-2 Apparatus

The description of the apparatus has been prepared by Mr. Bailey, who has also arranged for the wiring diagrams included in the description of the electronic equipment.

A. The Electronic Equipment:

(a) The Geophone: The piezo-electric effect is utilized as the basis of this pickup device. It consists of Rochelle salt crystals in the usual two-layer buildup. A conducting leaf between the layers provides one electrical connection, and a grounded foil metal sheath the second. This crystal unit measures approximately 2.5 in. x 0.75 in. x 0.25 in. and is mounted in a metal housing. One end of the

crystal unit is clamped and glued securely to a 1/4 in. platform, while the remainder swings free. This 'springboard' mounting produces a resonant frequency response of approximately 1,000 c.p.s. The geophones are of two forms, one enclosed in a metal pipe, the other designed to be clamped to a cylindrical specimen of Type 2D. Both types are shown in Figure 86.

(b) High-gain Amplifier: Signals from the geophone are applied to a conventional three-stage amplifier (6J7, 6J7, 6P5), having an over-all gain of 100,000. Each stage is well shielded and has decoupling in the plate supply lines. Attachment for high-impedance earphones is provided for listening purposes. See Figure 82 for wiring diagram (Bailey after Obert).

(c) Record Amplifier: This unit consists of a compressor, driver, rectifier, and power stages. The compressor stage consists of a duo-diode-pentode (6B8G) with part of its output rectified and applied back to its grid as a variable bias. The output of this stage is approximately a logarithmic function of the input. This is desirable so that large signals will not go off scale. The following stage (6P5) provides an impedance match with the rectifier (6ZY5). The rectified signal from this stage is applied as a bias to the output power stage (6F6). Variable response times can be achieved by selecting proper RC combinations in the grid circuit of the 6F6. See Figure 83 for wiring diagram (Bailey after Obert).

(d) Writer Circuit: The recorder consists of a magnetically-operated stylus and a moving tape. The stylus is an aluminum arm about 6 in. long, carrying a tension spring, pivots, and a small coil. This coil (which operates like a voice coil in a loudspeaker) provides the external plate impedance for the 6F6. Plate current variations in this power stage are therefore translated into mechanical movements of the stylus, which, in turn, records on Teledeltos paper. A telechron motor moves this tape at the rate of 1.5 in. per min.

For purposes of correlation of data and economy in design, each complete apparatus consists of two circuits or channels of similar construction. The two 6F6 plates of the recorder amplifiers are attached to terminals 1 and 2 of the writer circuit (see Figure 84 as drawn by Bailey after Obert). They thus obtain their plate supply voltage through L₁ and L₂ from source three. In the writer circuit (schematic), two of the arrows represent the styli of channels 1 and 2 respectively, while the third represents an additional stylus whose current supply is dependent upon a motor-driven switch arrangement to provide recorded time intervals on the margin of the tape. All three styli record on the same tape and are provided with current from source three.

(e) Power Pack: Operation is from a 110-volt A.C. source. A transformer (UTC-70518) provides for two 5-volt rectifier windings, two 6.3-volt windings, and a high-voltage winding. The filter consists of choke input, high LC combinations, and two regulator tubes (VR/150 and VR/75). Negative bias for the power stage (6F6) is obtained

by a second 5V4, operating off a portion of the high-voltage transformer winding. For wiring diagram of the Power Pack see Figure 85 (Bailey after Obert).

B. Hydraulic Press:

The hydraulic press shown in Figure 86 is known as a Southwark Tate Emery Universal Testing Machine, product of the Baldwin Southwark Division, Baldwin Locomotive Works, Philadelphia. It is a rugged hydraulic press and sensitive pressure indicator. It can be obtained in a number of sizes; the one in use at College Park has a maximum scale of 120,000 pounds.

Briefly, the operation is as follows: oil is pumped into a hydraulic cylinder, thus pushing a ram upwards. Attached to the ram is a work table, carrying two compression columns and a top crosshead. Between the top crosshead and the table is an adjustable crosshead supported from the fixed base of the press by means of the threaded columns shown in Figure 86. The motor shown in the illustration permits positioning the adjustable crosshead when clamping a specimen in the press, above or below this crosshead. (The wires shown in the illustration have nothing to do with the experiments here reported; they were installed for other work).

When pressure is applied to the hydraulic cylinder, a specimen attached between the adjustable crosshead and the top crosshead will be put in tension by the upward travel of the top crosshead. One placed below the adjustable crosshead will be compressed by the upward movement of the table.

The pressure generated in the hydraulic cylinder is transmitted to the indicator dial. By closing a valve, the pressure can be maintained on the specimen for some minutes with very low percentage loss.

Three decade ranges are provided on the same press. The dial numbers exposed on the complete scale are automatically changed by the mechanism selecting the range. The three maximum pressures available on the College Park press are: 1,200, 12,000, and 120,000 pounds.

W-3 Preliminary Tests

The first of the preliminary tests was made late on Friday afternoon, January 31; the others were run during the following two days, Saturday and Sunday, February 1-2. They were conducted by Dr. Obert, with Maurice Shelton operating the press. Notes were made by the Canadian observers.

The first test resulted in a broken geophone crystal. Only two clamping geophones were available. Shortly after, the second was damaged. Other trouble also developed, necessitating further repairs. These interruptions resulted in a somewhat haphazard

program of observing. The chief net result of the tests was that the observers became experienced in the technique involved and that a series of values of the bursting pressure was obtained for the specimens (in general two each) cut from the samples submitted from the Canadian mines. The description and the identification numbers of these samples are given in section W-8. The code used to describe the type of failure experienced in the bursting of a specimen is explained in section W-9. The crushing loads and the bursting code for each specimen broken in the preliminary tests are tabulated in section W-10.

W-4 Preparations for the Final Tests

The final tests were run Saturday and Sunday, February 8-9. As Dr. Obert had to be out of town on a business trip, his place was taken by Dr. Wilbur Duvall of his staff. As before, Shelton operated the press, and Langford, Bailey, and Hodgson were present throughout.

In the interval between the two series of tests, data forms had been prepared and a planned program laid out, designed to obtain as many qualitative data as possible with a minimum of risk to geophone crystals.

The planned program is outlined in section W-11. The form used for recording data is that appearing throughout section W-12. Prior to each test, the equipment was checked throughout by determining its response to the ticking of a watch laid in a prescribed relationship to the geophone. Although this is by no means a quantitative test, and fails to indicate the seat of any trouble that may occur, it is, nevertheless, a definite indication that everything is in good order if certain minimum criteria are met, e.g. if the observer can hear the watch so placed, when listening with the earphones, having the attenuator set at 47.5 Db.

Routine checking of the equipment between successive tests served to ensure that all recording and listening was done under optimum conditions.

W-5 Final Tests

It was felt that all data obtained in the final tests should be presented in this report, both the notes and the record tape. The forms appearing in section W-12 give the detailed notes on every specimen broken during the second week-end. The reproduction of the record tape sections in Figure 88 is complete except for four one-minute sections made during the earlier tests on specimen 17. These were spoiled in mounting and had to be discarded.

The following comments should be read with reference to the data sheets in section W-12 and to Figure 88. In the data sheets, pressures are given either in full or in decimals of thousands of pounds, e.g. 62.7 or 62,700 pounds. These values always refer to the dial readings. As the specimen cylinders are two square inches in cross-section, the given values must be divided by two to give pounds per square inch.

The following points should be noted:

- A. Twenty-two specimens are included in these final experiments, of which eighteen were type 2D, the others type X. All the 2D specimens were from samples sent from Canadian mines, Nos. 11 and 18 being from the same sample (N-3). Only one X-shaped specimen, No. 17, was from Canadian samples.
- B. The three most active specimens were all X-shaped. All were granite, No. 19 from North Carolina, No. 20 from Mineville, N.Y., and No. 21 from Lyon Mountain, N.Y.
- C. Most of the specimens began to show marked activity at about 50 per cent of their bursting strength, with high activity after 80 per cent was reached. This is shown most markedly in the case of specimens 7, 8, 12, and 16. These either burst with the geophone recording, or gave such swarms of warning microseisms that the pressure was released in time to avoid such an eventuality. Tests 34 and 40 (Figure 88) show evidence at the right-hand end of each that the specimen was close to bursting. The zero line is lifted. See similar evidence in Tests 87, 109, and 110.
- D. The microseisms were generally more numerous just at the beginning of a minute test run. The valve being shut after a fairly rapid rise of pressure, the activity was generally greater in the initial part of the run. See Tests: 59, 93, 94, 95, 96, 99, 103, 105, Figure 88. See Tests 40, 52, 91 for reverse case.
- E. Where the pressure was left at a given level for some time, the activity tended to be sporadic. See Tests: 68, 70, 106.
- F. A release of pressure, after a sustained level had been maintained for a minute or more, caused a temporary swarm of microseisms. These soon died out if the valve was again closed, holding the pressure at the decreased value.
- G. It seems necessary to correct a mistaken impression as to the conduction of microseisms across a rock-steel interface. In the case of specimen No. 12, the geophone was not successful in picking up the subaudible snaps (known, however, to be actively occurring in the specimen) when the geophone was laid on the table of the press. Later, when in contact with the side of the specimen under pressure, or when in contact with a specimen not under pressure; but itself in contact with one that was, the microseisms travelled across the interfaces; rock-to-rock, rock-to-rock, and rock-to-geophone. At the time, Hodgson insisted that there was something wrong with the first case, for it was quite out of line with his experiences in the mine.

On examining the notes for specimen No. 20, it will be seen (Note D) that there was good communication through the rock-steel interface. And this will be evident on referring to Test No. 96, where the record was made with the geophone lying free on the table of the press. It is not known, and it is now impossible to say, why there was no pick-up in the first part of the experiment on specimen No. 12.

- H. In general, the specimen did not break on the cemented joints. Specimen No. 9 was an exception; it did break on a joint.
- I. In the case of specimen No. 22, Langford pointed out that there was evidence of a chlorite fault with a displacement of a quarter-inch in the exposed face of the coned fragment.

- J. Sample N-3, from the International Nickel Company, showed no warning microseisms on the record (see No. 11 in section W-12). Warning microseisms were heard, but the gain (held constant or approximately so throughout the entire series) was not great enough to permit recording. The microseisms were sufficiently pronounced in this case (as heard in the headphones) to cause those listening to call for a release of pressure — too late to save the specimen, as shown in the notes.
- K. Microseisms were always generated in swarms when a specimen was spalling, but they also appeared in swarms in the case of specimens that were, apparently, not changed in any way by the pressure, for example, No. 5. When such specimens were removed from the press and examined, no cracks were visible, the specimen rang true and it did not break when dropped on the floor.
- L. Evidently the 2D shape is much more satisfactory than the X type, in addition to being much more easily prepared. In the X type, the wings tend to crack off and the specimen spalls on the inside of the geophone channels. It would be most interesting to test carefully made cylindrical specimens of much larger diameter in a heavier press, and to carry through an extended research on a much wider scale, making a determined effort to discover what mechanism, other than spalling or cracking, can cause these characteristic subaudible snaps.
- M. Thin specimens of each of the samples from the Canadian mines were studied by a petrographer of the U.S. Bureau of Mines. His report is given in full in section W-13.

W-16 Report by Professor Langford

The details of the experiments carried out at College Park, and descriptions of the apparatus, have been capably given by Dr. E.A. Hodgson and Mr. Ralph Bailey. My participation in this work was as an observer, and my comments must be in the nature of observations based on other people's work.

There is no doubt that microseisms are created in rock specimens under compressive stress, and that the number and intensity of the microseisms increases as the rock approaches the point of failure. This was not the case in every specimen, but in almost all. The microseisms, when heard in the headphones, have characteristic sounds that are similar for all types of rocks tested. It is said that they can be distinguished from mine noises when using the apparatus underground. I have made no underground observations, so cannot speak from experience. However, I believe it should be possible for a trained operator to distinguish microseisms from mine noises.

Petrographic studies are being made of all the specimens tested by the officer who makes such studies on all the rocks tested for microseisms at the Experimental Station. Although he was not as familiar with the Precambrian rock types as with younger rocks, it was felt that his observations would be especially valuable from a comparative viewpoint. From the work he has done for the Bureau of Mines, the petrographer has drawn the following general conclusions:

- (a) Coarse-grained rocks are weaker than fine-grained rocks of the same type.
- (b) Foliated rocks are weaker than massive rocks.
- (c) Hydrothermally altered rocks are weaker than fresh rocks.

He pointed out that these observations were very general, as they were many other features that had important influences on rock strength. However, these were the only rules that have much semblance of general application. Examination of the slides was not completed as this part of the report was written, but in a preliminary discussion with the petrographer it seemed likely that the general conclusions would apply to the Precambrian rocks.

The conclusions I would draw from my observations of the experiments may be stated as follows:

- A. Existing data on microseismisms are very meagre, and of a qualitative nature only. We have no definite knowledge of their place and mode of origin, neither do we know what they actually mean in terms of stress or strain. To attempt to apply such a relatively unknown theory to the solution of a practical problem is not wise. It may lead to many false alarms and a discrediting of the whole. It would be wiser to know more about microseismisms before trying to interpret those heard in mines.
- B. Microseismisms are only one aspect of stressed rocks. Our knowledge of the behaviour of rocks under pressure is very fragmentary. We know something about isolated phases of the problem, but there are many gaps in our knowledge. The subject is of vital interest to the geologist and geophysicist, as well as to the mining engineer. All the Precambrian rocks have been, and many still are, under considerable stress. We can never have a complete understanding of these rocks until we know a great deal more about their behaviour under stress.
- C. A proper understanding of the tectonics of our Precambrian area, which in turn is closely allied to the subject of ore deposits, cannot be gained without a great deal of experimentation on rocks under stress.
- D. We have no proper theories of rock failure. The so-called Strain Ellipsoid theory was formulated to explain the conditions that existed up to the point of rupture. In dealing with faults, shears, fractures, etc., we are dealing with material after failure. Present theories are very inadequate.

There is a great scope for research on rocks under pressure. This should not be undertaken for the sole purpose of predicting rockbursts. In the first place, one might be chasing a will-o-the-wisp, and the failure to get positive results might bring discredit on the whole program. Secondly, a broad and basic scientific investigation of rocks under pressure is needed, and the importance of the problem to the geologist and geophysicist may be lost sight of if it is undertaken merely from the rockburst angle.

Economic and structural geology badly need the stimulation that can come only from scientific contributions to our basic knowledge. There are virtually no organizations today

doing fundamental research on the problems of the Canadian Shield. This Shield is the largest and richest Precambrian area in the world. Canada should be the fountainhead for scientific research on all problems related to Precambrian geology. The mining industry, if it is to continue, must find new mines. The best place to find them is under the areas of overburden. Our present geological and geophysical knowledge is not equal to the task. In all this vast need, the problem of the behaviour of rocks under pressure is an important item.

I have discussed these conclusions with R.G.K. Morrison, of Mysore, India, a recognized authority on the practical side of rockbursts. He is in entire agreement with them.

W-7 Comments by Bailey and Hodgson

Professor Langford's two colleagues fully concur with his views and conclusions, as set forth above. They are such as could only properly be formulated by a geologist.

At the same time, there are two points that should be brought out, in view of the reasons for conducting the experiments at College Park at this time. It may reasonably be objected that our knowledge of microseismisms is by no means meagre; but, on the other hand, there is no doubt that 'we have no definite knowledge of their place and mode of origin, neither do we know what they actually mean in terms of stress and strain.'

It has been suggested in some quarters that microseismisms may simply be some form of interference arising in the electronics equipment. Here, in his own special field, Mr. Bailey is in a position to state that this is quite out of the question. Microseismisms, whatever be the mechanism of their origin, arise in the specimen under pressure.

As regards Professor Langford's remarks on the field of research on rocks under pressure (that they should not be undertaken specifically for the purpose of finding a predictor for rockbursts), his fellow delegates are in complete agreement. It is to be hoped that the type of research he has outlined may be undertaken and prosecuted with vigor.

W-8 Identification of Samples Received

Sample Sources and Dates Received

Designation

| | |
|-------|---|
| L1-L7 | Lake Shore Mines, Kirkland Lake, Ontario, October 7, 1946. |
| C1-C3 | Central Cadillac Mines, Cadillac, Quebec, December 30, 1946. |
| N1-N6 | International Nickel Company, Copper Cliff, Ontario, January 6, 1947. |
| S1-S2 | Sigma Mines, Bourslamaque, Quebec, January 14, 1947. |

| SD-No. | BM-No. | Identification |
|--------|--------|---|
| L1 | BM-487 | Basic Syenite - prepared specimen |
| L2 | -488 | Basic Syenite - rough |
| L3 | -489 | Syenite Porphyry - rough |
| L4 | -490 | Syenite Porphyry -rough |
| L5 | -491 | Red Syenite - rough |
| L6 | -492 | Red Syenite - rough |
| L7 | -493 | Altered Syenite Porphyry - rough |
| | | |
| C1 | BM-484 | Altered Aplite |
| C2 | -485 | Volcanic Sediments |
| C3 | -486 | Banded Iron |
| | | |
| N1 | BM-499 | Quartzite - Horizon 2400 ft. below surface |
| N2 | -500 | Rhyolite - 2400 ft. below surface |
| N3 | -501 | Peridotite - 1200 ft. below surface |
| N4 | -502 | Granite - 1500 ft. below surface |
| N5 | -503 | Norite - 4000 ft. below surface |
| N6 | -504 | Gabbro - 5000 ft. below surface |
| | | |
| S1 | BM-508 | Intrusive diorite-porphyry (known as Type C), from 350 ft. below surface in central part of the mine. Composed essentially of plagioclase crystals with minor hornblende; considered secondary alteration to carbonate, chlorate, and minor quartz. |
| S2 | -509 | Intrusive diorite-porphyry (known as Type C), from 1850 ft. below surface in central part of the mine. Composition as in S1, showing plagioclase, more hornblende, but less carbonate and chlorite alteration. |
| | | |

In addition to the above tabulated material and data, the International Nickel Company included a hand specimen of sulphide ore, too small to be used in the experiments; and Central Cadillac Mines furnished a map of its workings.

Three 2D-type cylinders were cut from each sample, of which two were run in the preliminary tests and one in the final, with the following exceptions:

- (a) None were cut from sample L-1, as it was not possible to obtain a full-sized cylinder from the prepared specimen sent.
- (b) Two cylinders only were obtained from samples C1 and N6, the other cores breaking short. One of each was run in the preliminary series and one in the final tests.
- (c) One cylinder only was unbroken as cut from sample C3. It was run in the final tests.
- (d) Five cylinders in all were cut from sample N3. Three of these were run in the preliminary tests and two in the final series.
- (e) An X-type specimen was cut from sample L4. It was run in the final tests.

In addition to the samples from Canadian mines, several samples from other sources were tested, as follows:

- (a) BM-475, Mt. Airy Granite from North Carolina, from which three 2D-type cylinders and one X-type specimen were cut. Of these, the three cylinders were run in the preliminary series and the X-type was tested in the final run.
- (b) BM-390, Granite from a depth of 1813 ft. in the hangingwall of the mine of the Republic Steel Corporation, at Lyon Mountain, N.Y., from which one X-type specimen was cut, which was tested in the final series.
- (c) BM-391, Granite from the hangingwall in the Upper Harmony Vein of the mine of the Republic Steel Corporation at Mineville, N.Y., from which one X-type specimen was cut, which was run in the final series of tests.

W-9 Code Designating Type of Rock Collapse

As a brief indication of the type of rock collapse under pressure, a three-digit designation was assigned according to the following schedule. It was used in connection with the 2D-type specimens only.

| Type of Failure | Type of Cone | Fragmentation |
|-----------------------------------|--------------------|-------------------|
| 1 Slow crush | 1 Two cones | 1 Grain size |
| 2 Crush | 2 One cone | 2 Small fragments |
| 3 Shatter | 3 Asymmetric cones | 3 Large fragments |
| 4 Violent shatter | 4 No cones | 4 Pieces |
| | | |

For example: 424 indicates that the specimen shattered violently, producing only one cone and several good-sized pieces.

W-10 Table of Comparative Data Obtained in Preliminary Tests

The following table summarizes the burst data obtained from the experiments performed during the first week-end. The columns, in order below, give the BM-numbers, the Sample Designation numbers, the values of the crush pressures (CP-1, CP-2, CP-3) for each of the test cylinders of each sample that were broken in the preliminary tests, and the Burst Code Designation (BCD-1, BCD-2, BCD-3) for each cylinder of the sample broken in those tests.

| BM-No. | SD-No. | CP-1 | CP-2 | CP-3 | BCD-1 | BCD-2 | BCD-3 |
|--------|--------|-------|--------|------|-------|-------|-------|
| 484 | C1 | 55.9 | --- | --- | (423) | --- | --- |
| 485 | C2 | 36.6 | 48.8 | --- | (244) | (344) | --- |
| 488 | L2 | 50.0 | 60.8 | --- | (344) | (323) | --- |
| 489 | L3 | 116.2 | 119.0 | --- | (421) | (444) | --- |
| 490 | L4 | 80.6 | 113.0 | --- | (421) | (422) | --- |
| 491 | L5 | 110.0 | * 98.0 | --- | (443) | (412) | --- |
| 492 | L6 | 47.9 | --- | 70.0 | (323) | --- | (422) |
| 493 | L7 | 40.0 | 91.0 | --- | (324) | (442) | --- |
| 499 | N1 | 57.1 | ° 35.0 | --- | (344) | # | --- |
| 500 | N2 | 77.8 | 80.0 | --- | (412) | (423) | --- |
| 501 | N3 | 84.9 | 24.0 | 78.4 | (443) | (144) | (423) |
| 502 | N4 | 96.0 | 91.0 | --- | (422) | (412) | --- |
| 503 | N5 | 67.8 | 70.0 | --- | (412) | (412) | --- |
| 504 | N6 | 116.4 | --- | --- | (422) | --- | --- |

* Pronounced slip plane showing gouge.

° Cylinder developed a crack.

Pressure not carried up to bursting, but a fracture was visible.

| BM-No. | SD-No. | CP - 1 | CP - 2 | CP - 3 | BCD-1 | BCD-2 | BCD-3 |
|--------|--------|--------|--------|--------|-------|-------|-------|
| 508 | S1 | 65.0 | 64.0 | --- | (412) | (424) | --- |
| 509 | S2 | 23.2 | 54.2 | --- | (344) | (424) | --- |

W-11 Test Procedure

The procedure in the preliminary tests was directed mainly towards determining the crushing strength of two of the three test cylinders prepared from each of the Canadian samples. These tests yielded two values of the load required to crush a cylinder of each sample, together with data from a somewhat haphazard program of listening and recording with the instrumental equipment at various pressure levels below that of bursting. Listening was carried out in many cases close to the breakdown. When swarms of microseisms gave sufficient warning, the geophone was removed from the specimen cylinder and the pressure again applied at slowly increasing values until the cylinder broke. In two such cases, the break occurred with the geophone in place. In each case, the crystal was damaged and had to be replaced.

Thus, in the preliminary tests, two values of the crushing load were obtained, in general, for each sample, leaving one prepared cylinder of each for the final tests. (In the case of BM-501, all three cylinders were broken. Two further specimens of this sample were prepared for the final tests). A general idea was also gained of the behaviour under load of each specimen type. From the data obtained, it became possible to estimate with reasonable accuracy the maximum safe load that could be applied to the remaining cylinder. Forms were prepared for recording data and the following procedure was adopted as standard for the final tests. These were arranged with a view to obtaining all possible data from each sample, without danger of breaking the geophone crystal.

Referring to the forms used in reporting the results of the final tests (see section W-12), the procedure adopted was as follows:

- (a) Calibrate the geophone by placing it at one end of a piece of board about 3"x6", lying on the bed of the press, having the concavity of the geophone arch downward. Place a watch at the other end of the board, about 4 inches away from the geophone. In the line marked Calibration, enter the number of the geophone and the channel used, at G and C respectively. If the equipment is all in order, the watch should be heard at an attenuation of 47.5 Db. After AMn enter the minimum value of the attenuator setting at which the watch ticks just begin to register on the recording apparatus. After AMx enter the value of the attenuator setting that will just allow the watch to record full scale.
- (b) Assign a serial specimen number for reference and enter it, together with the data as to sample source, specimen shape, and rock type, in the appropriate spaces on the top line of the form.

- (c) In the first column, enter the BM-number for the sample concerned, followed in the three lines below by the terminal decimals of that number. In the second column, list the value of the crush load (CL) obtained for each of the test cylinders already broken, entering the value for each cylinder opposite the terminal decimal of the BM-number concerned. Enter a T in the second column to designate the specimen represented in the current tests for the form concerned.
- (d) By examining the notes of the preliminary tests and noting the crush loads required to break the two previous cylinders of that sample, determine an Estimated Maximum Safe Load (EMSL) to be entered in the space provided in column 2.
- (e) In the column headed TL (Test Loads) compute and enter, in order descending, the following fractions of the EMSL, namely:

| | | | |
|----|-----|-----|-----|
| .5 | .8 | 1.0 | 1.2 |
| .6 | 1.0 | 1.2 | 1.4 |
| .7 | | | |
| .8 | | | |

- (f) The set having been calibrated prior to each specimen run, raise the pressure to the first TL-value, i.e. half the EMSL. Run a carefully guarded test, listening and recording for at least one full minute, and noting the attenuator setting used under AR (Attenuator Reading) and the channel used under C. Enter the total number of microseisms heard in the minute interval under the heading AN (Audible Number). If the run is longer than a minute, the number entered is to be the average per minute. Enter under RN the recorded number, selecting and indicating the minute used where the run is greater than a minute. If any room noises should cause offsets on the tape, they are to be marked in pencil on the record. Make every effort to keep the tape clear of all such disturbances. If it is necessary to repeat any test, retain the acceptable data only on the forms and mark the tape xxxxx for the section abandoned. Repeat the procedure of this section for the next three lines, dealing with .6, .7, and .8, respectively of the EMSL.
- (g) Lower the pressure to a safe value, remove the geophone, raise the pressure to the full value of the EMSL, then lower the pressure again to a safe value, replace the geophone, and repeat the procedure of section (F) above for a repeat measure at .8 (EMSL) and for a measure at 1.0 (EMSL). These measures complete the entries for Reset No. 1. Follow the procedure of this section for the values under Reset No. 2 and Reset No. 3, using the test pressures already computed and entered in column 3.

- (h) In the event that the specimen has not yet been broken, remove the geophone and carry the pressure up to the bursting point. Enter that value after the heading Crush Load. Determine the code designation for the burst and enter it after the heading Code. Compute for each test load used the percentage value of TL/CL and enter these in the column headed BV (percentage of bursting value).
- (i) Keep a close record of all observed data in each test under the heading Notes. If space is too limited, assign to such notes an index letter designating full entries in the lines at the bottom of the tabulation.
- (j) In the column headed T enter the serial number of the test, to be used later to identify the record section concerned.

W-12 Data Forms

| No. 1 | | Source=C1 | | Shape=2D | | | Type=Altered Aplite | | |
|-------------|-------------|-------------|-----------|-----------|-----------|----------|---------------------|-----------|----------|
| BM-484 | CL | TL | AN | RN | AR | C | Notes | BV | T |
| .1 | 55.9 | 25.0 | 34 | 4 | 15 | B | Very faint snaps | 56 | 1 |
| .2 | T | 30.0 | 23 | 3 | 15 | B | Very faint snaps | 67 | 2 |
| .3 | | 35.0 | 46 | 4 | 15 | B | Very faint snaps | 78 | 3 |
| EMSL | 50.0 | 40.0 | 62 | 30 | 15 | B | A, B, C | 89 | 4 |

Reset No. 1

Reset No. 2

Crush Load=45.0 Code=244 Calibration: G=1, G=B, AMn=45, AMX=32

- Note: A. Only two specimens were obtained from sample C1, and only one of these was broken in the preliminary tests.
- B. Some medium-sized snaps registered at 40,000.
- C. In Reset No. 1, the pressure was raised to 50,000 without breaking the specimen. It was lowered to 35,000 and then rapidly raised. The specimen burst at 45,000. The geophone crystal was broken by the burst. Pending repair,

DOMINION OBSERVATORY

Geophone 2 (of the clamp-on style, as was No. 1) was used for the further experiments.

Note: The complete form is shown for specimen No. 1, although in this case there are no entries in the reset sections. From this point on, only that part of each form will be given in which some data are entered. This will conserve space without the omission of any experimental data.

| No. 2 | Source=C2 | Shape=2D | | | | Type-Volcanic Sediments | | | |
|-----------------|-----------|----------|----|-------------------------------|----|-------------------------|-------------|--------|---|
| BM-485 | CL | TL | AN | RN | AR | C | Notes | BV | T |
| .1 | 36.6 | 20.0 | 25 | 5 | 15 | B | Poor record | 51 | 5 |
| .2 | 48.8 | 24.0 | 16 | 4 | 15 | B | Good record | 61 | 6 |
| .3 | T | 28.0 | 74 | N | 15 | B | A,B | 71 | 7 |
| EMSL | 40.0 | 32.0 | 80 | N | 15 | B | C | 81 | 8 |
| Crush Load=39.3 | | Code=344 | | Calibration: G=2, G=B, AMn=45 | | | | AMx-22 | |

Notes: A. The letter N in the column headed RN indicates that the recorded snaps were numerous.

B. Very active during this test, especially at the beginning.

C. Good record; some snaps 3/4 scale.

| No. 3 | Source=L2 | Shape=2D | | | | Type-Basic Syenite | | | |
|--------|-----------|----------|----|----|----|--------------------|-------|----|----|
| BM-488 | CL | TL | AN | RN | AR | C | Notes | BV | T |
| .1 | 50.0 | 25.0 | | | 15 | B | A | 42 | 9 |
| .2 | 60.8 | 30.0 | 3 | 1 | 15 | B | B | 50 | 10 |
| .3 | T | 35.0 | 20 | 9 | 15 | B | C | 58 | 11 |
| EMSL | 50.0 | 40.0 | 30 | 21 | 15 | B | D | 66 | 12 |

| No. 3 | Source=12 | Shape=2D | | | Type=Basic Syenite | | | | |
|-----------------|-----------|----------|----|--------------------------------|--------------------|--|--------|----|----|
| Reset No. 1 | 40.0 | 10 | 15 | 15 | B | | E | 66 | 13 |
| | 50.0 | C | N | 15 | B | | F | 83 | 14 |
| Crush Load=60.0 | | Code=423 | | Calibration: G=2, C=B, AMn=45, | | | AMx=22 | | |

- Notes: A. Poor recording; a few weak snaps.
 B. Recording interrupted by wind.
 C. Recording only fair; one 3/4-scale snap near the end of the record.
 D. One nearly full-scale snap recorded.
 E. One 3/4-scale snap recorded; much trash on record; wind was howling.
 F. Record good. All above a trashy zero line is real.
 G. Before testing this specimen, it was observed to have a joint plane bevelling off from about central position on the end of the specimen to come out on the curved side about 3/4 of the way down. The joint was solidly cemented (natural). The specimen did not break at the joint.

| No. 4 | Source=L3 | Shape=2D | | | Type=Syenite Porphyry | | | | |
|------------------|-----------|----------|----|--------------------------------|-----------------------|---|-----------------------|----|----|
| BM-489 | CL | TL | AN | RN | AR | C | Notes | BV | T |
| .1 | 116.2 | 50.0 | C | | 15 | B | A. Faint snaps | 50 | 15 |
| .2 | 119.0 | 60.0 | C | 7 | 15 | B | B | 60 | 16 |
| .3 | T | 70.0 | C | 9 | 15 | B | Some snaps half scale | 70 | 17 |
| EMSL | 100.0 | 80.0 | 70 | N | 15 | B | Record good | 80 | 18 |
| Crush Load=100.0 | | Code=422 | | Calibration: G=2, C=B, AMn=40, | | | AM _x =25 | | |

- Notes: A. The letter C in columns AN or RN indicates that the audible snaps or the recorded ones, as the case may be, are continuous.
 B. Two or three 3/4 scale snaps on record.

| No. 5 | | Source=L4 | | Shape=2D | | | Type-Syenite Porphyry | | |
|-------------|-------|-----------|----|------------------------------------|----|---|-----------------------|----|----|
| BM-490 | CL | TL | AN | RN | AR | C | Notes | BV | T |
| .1 | 80.6 | 40.0 | | | 15 | B | A | | 19 |
| .2 | 113.0 | 48.0 | 20 | | 15 | B | B | | 20 |
| .3 | T | 56.0 | 50 | 3 | 20 | B | C | | 21 |
| EMSL | 80.0 | 64.0 | 70 | 2 | 20 | B | D | | 23 |
| Reset No. 1 | | 64.0 | 15 | 7 | 20 | B | E | | 23 |
| | | 80.0 | 40 | 12 | 20 | B | F | | 24 |
| Reset No. 2 | | 80.0 | 60 | 27 | 20 | B | G | | 25 |
| | | 96.0 | 80 | 22 | 20 | B | H | | 26 |
| Crush Load= | | Code= | | Calibration: G= , C= , AMn= , AMx= | | | | | |

- Notes: A. A few faint snaps heard. Record poor; much trash.
 B. Some 1/4-scale snaps, but record is trashy.
 C. Record now OK, except for parts marked x.
 D. Two snaps about half-scale.
 E. Most of the snapping was recorded; not very lively.
 F. One snap recorded full scale.
 G. Record is good during this test.
 H. Record good, about 3/4-scale.

This specimen was the cylinder which was fluted owing to a flaw in the diamond drill. It started to crack audibly at 95,000. It was then run up to 100,000 in the expectation that it would break. It did not. It was brought down to 80,000 and the geophone put in place. The geophone was removed after the last test at 96,000. The pressure was run up to 112,000 with some audible snapping. The specimen did not break. Specimen preserved.

No. 6 Source=L5 Shape=2D Type=Red Syenite

| BM-491 | CL | TL | AN | RN | AR | C | Notes | BV | T |
|--------|-------|------|----|----|----|---|-------|----|----|
| .1 | 110.0 | 50.0 | | 1 | 20 | B | A | 52 | 27 |
| .2 | 98.0 | 60.0 | C | 4 | 20 | B | B | 63 | 28 |
| .3 | T | 70.0 | | 14 | 20 | B | C | 73 | 29 |
| EMSL | 100.0 | 80.0 | 30 | 14 | 20 | B | D | 83 | 30 |

Crush Load=96.0 Code=443 Calibration: G=2, C=B, AMn=45, AMx=25

Notes: A. Continuous faint snaps. Record OK.

B. Some snaps recorded full scale.

C. Quiet, record poor, interference from drive belt.

D. Number of snaps full scale at beginning, then falling off in rate of incidence.

A slip plane was observed on the face of the crushed cone of this specimen. Gouge in plane. The specimen broke very violently, breaking the glass shield.

No. 7 Source=L6 Shape=2D Type=Red Syenite

| BM-492 | CL | TL | AN | RN | AR | C | Notes | BV | T |
|--------|------|------|----|----|----|---|-------------|-----|----|
| .1 | 47.9 | 25.0 | C | 10 | 20 | B | A | 63 | 31 |
| .2 | T | 30.0 | 10 | 4 | 20 | B | B | 75 | 32 |
| .3 | 70.0 | 35.0 | C | 17 | 20 | B | C | 87 | 33 |
| EMSL | 50.0 | 40.0 | C | C | 20 | B | Good record | 100 | 34 |

Crush Load=40.0 Code=213 Calibration: G=2, C=B, AMn=42, AMx=17

- Notes: A. Faint snaps. Ten sharp ones recorded.
 B. No snaps of any size recorded. Four small ones.
 C. Record good. Snaps recorded about 1/4-scale at the beginning of the record, and about 1/2-scale at the end.

The specimen was run for about three minutes at 40,000. A good record was obtained. It grew progressively more active and then burst. Prior to the test, the specimen was observed to have cracks (cemented naturally) across the end and traversing the speci-

No. 8 Source=L7 Shape=2D Type=Altered Syenite Porphyry

| HM-493 | CL | TL | AN | RN | AR | C | Notes | BV | T |
|-------------|------|------|----|----|----|---|-----------|----|----|
| .1 | 40.0 | 25.0 | 2 | 5 | 20 | B | A | 57 | 35 |
| .2 | 91.0 | 30.0 | 20 | 6 | 20 | B | Record OK | 68 | 36 |
| .3 | T | 35.0 | N | 32 | 20 | B | B | 79 | 37 |
| EMSL | 50.0 | 40.0 | N | 30 | 20 | B | C | 91 | 38 |
| Reset No. 1 | | 40.0 | | 26 | 20 | B | D | 91 | 39 |
| | | 45.0 | N | N | 20 | B | E | | |

Crush Load=44.0 Code-324 Calibration: G=2, C=B, AMn=42, AMx=17

- Notes: A. Record OK where not x'd out.
 B. Some snaps recorded full scale.
 C. Record is good; rapid falling off of rate of incidence.
 D. Very quiet. Record poor, owing to drive belt interference.
 E. This specimen was very noisy at 45,000. There was a sudden build-up, indicating failure, so pressure was released and specimen removed. Cracks were observed from end to end. Replaced in press. Broke at 44,000. In the Reset No. 1, the specimen was run up to 50,000. A chip broke off and then the specimen broke later at the lower value indicated.

| No. 9 | | Source=N1 | | Shape=2D | | | Type=Quartzite from 2400' depth | | |
|-----------------|------|-----------|----|--------------------------------|----|---|---------------------------------|----|----|
| BM-499 | CL | TL | AN | RN | AR | C | Notes | BV | T |
| .1 | 57.1 | 20.0 | 15 | 0 | 20 | B | | 39 | 41 |
| .2 | 35 + | 24.0 | 10 | 2 | 20 | B | A | 47 | 42 |
| .3 | T | 28.0 | | | 20 | B | B | 55 | 43 |
| EMSL | 40.0 | 32.0 | 20 | 7 | 20 | B | Signs of recording | 63 | 44 |
| Reset No. 1 | | 32.0 | | | 20 | B | C | 63 | 45 |
| | | 40.0 | 6 | 9 | 20 | B | Recorded only a few | 78 | 46 |
| Reset No. 2 | | | | | | | D | | |
| | | 48.0 | C | 14 | 20 | B | Record good; all real | 94 | 47 |
| Crush Load=51.0 | | Code=344 | | Calibration: G=2, C=B, AMn=45, | | | AMx=30 | | |

- Notes: A. Two snaps recorded, about 1/4-scale.
 B. Trouble with carbon on stylus; interfered with the recording.
 C. Very few audible snaps; none recorded.
 D. Omitted this test. Did not reset. The specimen broke on a joint. Gouge on face of the cone. One such joint was noticed before the specimen was tested.

| No. 10 | | Source=N2 | | Shape=2D | | | Type=Rhyolite from 2400' depth | | |
|--------|------|-----------|----|----------|----|---|--------------------------------|----|----|
| BM-500 | CL | TL | AN | RN | AR | C | Notes | BV | T |
| .1 | 77.8 | 35.0 | 50 | 0 | 20 | B | No record | 45 | 48 |
| .2 | 80.0 | 42.0 | 32 | 3 | 20 | B | A | 54 | 49 |
| .3 | T | 49.0 | 30 | 3 | 20 | F | B | 63 | 50 |

No. 10 Source=N2 Shape=2D Type=Rhyolite from 2400' depth

EMSL 70.0 56.0 50 2 20 B Very faint 72 51

Reset No. 1 70.0 C N 20 B Very active 89 52

Crush Load=78.0 Code=412 Calibration: G=2, C=B, AMn=45, AMx=32

Notes: A. Twenty-five snaps in first half minute, five in next quarter minute, two in last quarter.

B. Faint snaps. Recording OK.

Snapping was very pronounced at 70,000. Pressure lowered to 65,000, then brought back to 70,000 and held for a time, but the snapping had ceased. Pronounced joint noted on untested specimen.

No. 11 Source=N3 Shape=2D Type=Peridotite from 1200' depth

BM-501 CL TL AN RN AR C Notes BV T

.1 84.2 35.0 C 0 20 B None recorded 47 53

.2 24.0 42.0 C 0 20 B Very weak snaps 56 54

.3 78.4 49.0 C 0 20 B Even more quiet 65 55

EMSL 70.0 56.0 C 0 20 B Very quiet 75 56

65.0 C 1 20 B A 87 57

Reset No. 1 70.0 C 1 20 B Very quiet 93 58

Crush Load=75.0 Code=444 Calibration: G=2, C=B, AMn=45, AMx=25

Notes: A. Did not reset. Very quiet.

Pressure continued without resetting to 75,000. Burst was very pronounced; surges appeared just before it. The pressure was lifted but not quickly enough.

Five specimens in all from this sample were broken. The test here outlined was on specimen BM-501.4. In every case, there was ample warning so far as the audible snapping was concerned, but the gain was not high enough to register the relatively faint snaps generated by this type of rock.

| No. 12 | Source=N4 | Shape=2D | | | | Type=Granite from 1500' depth | | | |
|-----------------|-----------|----------|----|-------------------|------|-------------------------------|--------|----|----|
| BM-502 | CL | TL | AN | RN | AR | C | Notes | BV | T |
| .1 | 96.0 | 45.0 | C | 7 | 20 | B | A | 67 | 59 |
| .2 | 91.0 | 54.0 | C | C | 20 | B | B | 81 | 60 |
| .3 | T | | | | | | | | |
| EMSL | 90.0 | | | | | | | | |
| Crush Load=67.0 | | Code=444 | | Calibration: G=2, | C=B, | AMn=42, | AMx=17 | | |

Notes: A. Rapid decay; recording OK.

B. Very active; pressure released.

Noted crack across specimen before test. Decided to use cylindrical geophone No. 59 after test started. Checked this geophone and found it OK. Laid it on bed of press beside the supporting steel bearing plate. Picked up very little across the interface, steel to steel. Then laid geophone on top of a pile of steel pieces, in contact with the specimen under pressure. The pick-up was practically as good as with the special clamp-on geophones. Then tried several pieces of rock between the specimen under pressure and the geophone and the pick-up was apparently as good as before. Ran the pressure up to 54,000. Chip came out. Very active while the chip was splitting out, then remarkably quiet. Geophone removed and specimen burst at 67,000.

Geophone trouble developed just as test was beginning. The first tube noise was becoming very strong also. Replaced the 6J7 tube in the B-channel, with satisfactory results.

DOMINION OBSERVATORY

| No. 13 | | Source=N5 | | Shape=2D | | | Type=Norite from 4000' depth | | | |
|--------|------|-----------|----|----------|----|---|------------------------------|----|----|--|
| BM-503 | CL | TL | AN | RN | AR | C | Notes | BV | T | |
| .1 | 67.6 | 35.0 | 9 | 0 | 20 | B | Recorder OK | 57 | 61 | |
| .2 | 70.0 | 42.0 | 10 | 2 | 20 | B | Very small, Record OK | 69 | 62 | |
| .3 | T | 49.0 | C | 0 | 20 | B | More lively | 80 | 63 | |
| EMSL | 70.0 | 56.0 | C | 3 | 20 | B | A little more lively | 92 | 64 | |

| Reset No. 1 | | Ommitted reset | | | | | | | | |
|-------------|--|----------------|---|---|----|---|-------------|---|-----|----|
| | | 70.0 | C | 7 | 20 | B | Very active | A | 115 | 65 |

| Reset No. 2 | | A, B | | | | | | | | |
|-------------|--|------|--|--|--|--|--|--|-----|--|
| | | 73.0 | | | | | | | 120 | |

Crush Load=61.0 Code=323 Calibration: G=2, C=B, AMn=42, AMx=17

Notes: A. The meaning of readings at 115 and 120 per cent of the bursting value will be explained in note below.

B. Started to spall; removed from the press.

When the specimen spalled at 73,000, the pressure was dropped and the specimen did not burst. When, on raising the pressure, the specimen burst, the value was only 61,000 pounds.

| No. 14 | | Source=N5 | | Shape=2D | | | Type=Gabbro from 5000' depth | | | |
|--------|-------|-----------|----|----------|----|---|------------------------------|----|----|--|
| BM-504 | CL | TL | AN | RN | AR | C | Notes | BV | T | |
| .1 | 116.4 | 50.0 | 10 | 1 | 20 | B | A | 44 | 66 | |
| .2 | T | 60.0 | N | 5 | 20 | B | B | 52 | 67 | |
| .3 | | 70.0 | C | N | 20 | B | C | 61 | 68 | |
| EMSL | 100.0 | 80.0 | C | 3 | 20 | B | D | 70 | 69 | |

No. Source=N5 Shape=2D Type=Gabbro from 5000' depth

| | | | | | | | | |
|------------------|----------|---|--------------------------------|----|---|---|---------------|----|
| Reset No. 1 | | | | | | | Omitted reset | |
| | 85.0 | C | N | 20 | B | E | 74 | 70 |
| Crush Load=115.0 | Code=422 | | Calibration: G=2, C=B, AMn=37, | | | | AMx=15 | |

- Notes: A. Snaps small and weak. Recording OK.
 B. One full-scale snap. No decay.
 C. Ran tape for two minutes. Specimen spalled and was then quiet.
 D. Decay, but recording was OK.
 E. Ran tape five minutes. Markedly sporadic.

Small pieces broke off top and bottom edges when specimen was first clamped in the press. A preliminary test load of 40,000 pounds was found safe and the test was then run as indicated above, without any resetting.

No. 15 Source=S1 Shape=2D Type=Intrusive Diorite Porphyry

| BM-508 CL | TL | AN | RN | AR | C | Notes | BV | T |
|-----------|------|------|----|----|----|--------------------|----|----|
| .1 | 65.0 | 30.0 | 5 | 1 | 20 | B A | 45 | 71 |
| .2 | 64.0 | 36.0 | | | 20 | B Occasional Snaps | 54 | 72 |
| .3 | T | 42.0 | 12 | 3 | 20 | B Faint snaps | 63 | 73 |
| EMSL | 60.0 | 48.0 | C | | 20 | B B | 72 | 74 |

| | | | | | | | | |
|-------------|------|---|---|----|---|------------|---------------|----|
| Reset No. 1 | | | | | | | Omitted reset | |
| | 60.0 | C | C | 20 | B | Very noisy | 90 | 75 |

| | | | | | | | | |
|-----------------|----------|--|------------------------|--|--|--|----------------|--|
| Crush Load=67.0 | Code=424 | | Calibration: G=1, C=B, | | | | AMn=45, AMx=15 | |
|-----------------|----------|--|------------------------|--|--|--|----------------|--|

- Notes: A. Very faint snaps. Recording OK.
 B. Decaying from continuous to occasional snaps.

This specimen was obtained from a depth of 350'. Compare with Test Specimen 16, below. It was run up to 60,000 pounds. Very noisy. Cut down to 55,000 as quickly as possible. Small chips had spalled. Did not dare replace the geophone. Ran the pressure up to 67,000, where the specimen burst violently.

| No. 16 | | Source=S2 | | Shape=2D | | | Type=Intrusive Diorite Porphyry | | |
|-----------------|------|-----------|----|-------------------|------|------|---------------------------------|----|----|
| BM-509 | CL | TL | AN | RN | AR | C | Notes | BV | T |
| .1 | 23.2 | 12.5 | 6 | 5 | 20 | A | A | 23 | 76 |
| .2 | 54.2 | 15.0 | 8 | 3 | 20 | A | | 27 | 77 |
| .3 | T | 17.5 | | | | | Omitted | | |
| EMSL | 25.0 | 20.0 | 7 | 6 | 20 | A | Very small snaps | 36 | 78 |
| | | 25.0 | | 3 | 20 | A | B | 46 | 79 |
| Reset No. 1 | | 30.0 | | 3 | 20 | A | Three small real snaps | 55 | 80 |
| | | 35.0 | 10 | 1 | 20 | A | C | 64 | 81 |
| Reset No. 2 | | 40.0 | 23 | | 20 | A | Recorder OK. | 73 | 82 |
| | | 45.0 | C | 4 | 20 | A | D | 82 | 83 |
| Reset No. 3 | | 55.0 | C | C | 20 | A | | 99 | 84 |
| Crush Load=55.0 | | Code=344 | | Calibration: G=1, | C=A, | AMn= | , AMX= | | |

Notes: A. Recorded four snaps at start, then rapid decay.
 B. Omitted reset.
 C. Omitted reset.
 D. Faint. Four recorded. Variable zero due to snaps.

This specimen was from a depth of 1850'. A calibration was made, but the notes were mislaid. The set was however, in good order throughout the test. Compare this specimen (16) with the previous one (15), which came from a much shallower depth.

| No. 17 | | Source=L4 | | Shape=X | | | Type=Syenite Porphyry | | | |
|----------------|-------|-----------|----|--------------|----|-------|-----------------------|---------|--------|--|
| BM-490 | CL | TL | AN | RN | AR | C | Notes | BV | T | |
| .1 | | 60.0 | 30 | | 20 | B | Record good. A | | | |
| .2 | | 72.0 | N | 10 | 20 | B | B | | | |
| .3 | | 84.0 | 16 | | 20 | B | C | | | |
| EMSL | 120.0 | 96.0 | 30 | | 20 | B | D | | | |
| Omitted reset. | | | | | | | | | | |
| Reset No. 1 | | 118.0 | C | 12 | 20 | B | E | | 85 | |
| Crush Load= | | Code= | | Calibration: | | G=59, | C=B, | AMn=37, | AMx=22 | |

- Notes: A. Record good; small surge. Unfortunately, all but the last section of this record was spoiled in mounting.
 B. Record mostly good.
 C. Record good.
 D. Record good; half-scale snap is real.
 E. Record good, amplitude tapering off.

The procedure outlined in section W-11 was varied with the X-type specimens. There was no resetting. The geophone was left in place except when the specimen was dangerously close to bursting, when it was removed from the run-up of pressure and then replaced. (This is easily done for these specimens for the geophone is the cylinder type and is not clamped on but is simply laid in the cradle at the side of the specimen).

In this test the pressure was stopped at 116,000 and then raised to 118,000. Pressure was released very gradually from 118,000 to 110,000. Brought up again to 118,000. The record was good throughout. The specimen was not broken. The press was too small to break a specimen of so great cross-section.

| No. 18 | | Source=N3 | | Shape=2D | | | Type=Peridotite from 1200' depth | | | |
|-----------------|----|-----------|----|--------------|----|------|----------------------------------|---------|--------|--|
| BM-501 | CL | TL | AN | RN | AR | C | Notes | BV | T | |
| Crush Load=45.0 | | Code=444 | | Calibration: | | G=2, | C=B, | AMn=45, | AMx=25 | |

Notes: Tested the No. 1 geophone repaired by Duvall. It gave the above calibration values on test.

This specimen is the fifth made from the same sample. No warning was recorded by any of the specimens of this rock. Audible warning only was detected.

It was decided to run this specimen up to 70,000 without the geophone and then go back and make tests. The specimen broke unexpectedly at 45,000 pounds.

| No. 19 | | Source=N.C. | | Shape=X | | | Type=Mt. Airy Granite, N. Carolina | | | |
|-----------------|----|-------------|----|-------------------------|----|---|------------------------------------|---------|--------|--|
| BM-475 | CL | TL | AN | RN | AR | C | Notes | BV | T | |
| .1 | | 30.0 | 10 | 6 | 20 | B | A | 73 | 86 | |
| .2 | | 40.0 | C | C | 20 | B | B | 98 | 87 | |
| Crush Load=41.0 | | Code= | | Calibration: G=59, C=B, | | | | AMn=45, | AMx=35 | |

Notes: A. One 3/4 scale snap, real. Record OK.

B. See notes for specimen No. 17 as to X-type procedure.

The initial pressure was raised to 45,000. Then one wing began to break. Pressure was then released to 29,000 and brought up to 30,000 with the results shown above. At 40,000 there was a great deal of snapping. The wing, broken off in the initial run, was removed from the specimen while recording. Fracture was noted on the main portion when taken from the press. The top of this specimen was not bevelled. Bevelled steel plates were used and it is thought that the pressure was not delivered uniformly, resulting in the early failure.

| No. 20 | | Source=N.Y. | | Shape=X | | | Type=Granite, Mineville, N.Y. | | | |
|--------|----|-------------|----|---------|----|---|-------------------------------|----|----|--|
| BM-391 | CL | TL | AN | RN | AR | C | Notes | BV | T | |
| .1 | | 20.0 | C | N | 20 | B | Record good | 31 | 88 | |
| .2 | | 25.0 | C | N | 20 | B | Record good | 38 | 89 | |
| .3 | | 30.0 | C | N | 20 | B | Good record, full scale | 46 | 90 | |
| EMSL | | 35.0 | C | C | 20 | B | Good record, full scale | 54 | 91 | |

| No. 20 | Source=N.Y. | Shape=X | | | | Type=Granite, Mineville, N.Y. | | | |
|-----------------|-------------|---------|--|----|---|-------------------------------|-----|----|--|
| Reset No. 1 | 40.0 | C | C | 20 | B | A | 62 | 92 | |
| | 45.0 | C | N | 20 | B | B | 69 | 93 | |
| Reset No. 2 | 50.0 | C | N | 20 | B | C | 77 | 94 | |
| | 55.0 | C | C | 20 | B | Very active | 85 | 95 | |
| Reset No. 3 | 60.0 | C | C | 20 | B | D | 92 | 96 | |
| | 65.0 | C | C | 20 | B | E | 100 | 97 | |
| Crush Load=65.0 | | Code= | Calibration: G=59, C=B, AMn=45, AMx=27 | | | | | | |

- Notes: A. After 35,000, the specimen was removed and observation made. There was no sign of fracture. One edge was powdery, owing to rough edge ground off by the press. The specimen was then returned to the press and pressure brought up again to 40,000 and continued as indicated above.
- B. Record good; half scale.
- C. Became very violent at 50,000. Pressure released. Dropped to 48,000, brought back to 50,000. Very active.
- D. Very active, then decreasing. The geophone was moved to the bed of the press and held in position with a piece of wood. As can be seen by the record (Figure 88), this time the energy was transferred across the steel-to-steel interface without noticeable loss.
- E. Geophone was on bed of press. As pressure reached bursting value, the specimen yielded and the snapping was communicated to the geophone on the bed of the press. It was possible to witness the gradual breakdown of the specimen. However, it finally broke violently.

| No. 21 | Source=N.Y. | Shape=X | | | | Type=Granite, Lyon Mt., N.Y. | | | |
|--------|-------------|---------|----|----|----|------------------------------|----------------------|----|-----|
| BM-390 | CL | TL | AN | RN | AR | C | Notes | BV | T |
| .1 | | 20.0 | 3 | 15 | 20 | B | Large to small snaps | | 98 |
| .2 | | 25.0 | C | N | 20 | B | As above | | 99 |
| .3 | | 30.0 | 22 | 15 | 20 | B | Quiet uniform record | | 100 |

| No. 21 | Source=N.Y. | Shape=X | | | Type=Granite, Lyon Mt., N.Y. | | |
|-------------|-------------|--------------------|---|----|------------------------------|----------------------|--------|
| EMSL | 35.0 | C | N | 20 | B | OK throughout | 101 |
| Reset No. 1 | 40.0 | C | C | 20 | B | Half-scale snaps | 102 |
| | 45.0 | C | N | 20 | B | Lively; falling off | 103 |
| Reset No. 2 | 50.0 | C | N | 20 | B | A | 104 |
| | 55.0 | C | N | 20 | B | Falling off a little | 105 |
| Reset No. 3 | 60.0 | C | N | 20 | B | B | 106 |
| | 65.0 | C | N | 20 | B | C | 107 |
| Reset No. 4 | 70.0 | C | C | 20 | B | D | 108 |
| | 75.0 | C | C | 20 | B | E | 109 |
| Crush Load= | Code= | Calibration: G=59, | | | C=B, | AMn=37, | AMx=15 |

- Notes: A. A curious buzzing sound, which had been vaguely troublesome as background noise when listening, suddenly stopped at this point. Set worked well, both before and after, but was much more comfortable to work with after the buzzing stopped.
- B. Two-minute run, active, no decay.
- C. Two-minute run, very active.
- D. Five-minute run, very active.
- E. Five-minute run, very active; wing broke off the X-shaped specimen.

At 80,000 the microseismic activity was very great and continued so for a long run of over five minutes (T=100). The pressure dropped slowly from 80,000 to 40,000. Held there and released. Specimen removed and preserved. One wing fractured. Poorly defined foliation (Langford).

The procedure was varied in the case of this specimen. It was put in the press and a cylindrical geophone put in one of the side slots. Then the pressure was run up in stages of 5,000 pounds, from 20,000 to 80,000 as indicated above. The specimen did not crush. T=100 is included in Figure 88, showing the record at 80,000 pounds.

| No. 22 | | Source=C3 | | Shape=2D | | Type=Banded Iron | | | |
|-----------------|------|-----------|----|-------------------|---|-----------------------|---------|--------|--|
| EM-485 CL | TL | AN | RN | AR | C | Notes | BV | T | |
| .1 T | 10.0 | | | 20 | B | Very quiet. Record OK | 16 | 111 | |
| .2 | 20.0 | C | 3 | 20 | B | A | 32 | 112 | |
| .3 | 30.0 | C | | 20 | B | Quieter, recorder OK | 48 | 113 | |
| EMSL | 40.0 | C | | 20 | B | B | 65 | 114 | |
| | 50.0 | C | 2 | 20 | B | C | 81 | 115 | |
| Reset No. 1 | 60.0 | C | 2 | 20 | B | Quiet | 97 | 116 | |
| Crush Load=62.0 | | Code-324 | | Calibration: G=2, | | C=B, | AMn=37, | AMx=15 | |

Notes: A. Snaps weak, but one recorded half scale.
 B. Very faint and decaying.
 C. Small snaps, and decaying.

Only one specimen of this sample was prepared, as it was very friable. Hence there was no previous test value to use as a guide. Procedure was carried through with considerable caution. Specimen broke without warning. Broke clamping geophone No. 2. Chlorite fault in specimen; 1/4 inch movement disclosed by the fragments (Langford).

W-13 Report on Petrography of Rocks from Canadian Mines

The following report dealing with the petrography of rocks submitted by Canadian mines for the program reported in the preceding sections was prepared by H.W. Jaffe, Petrographer, U.S. Bureau of Mines Experimental Station, College Park, Md.

Group I - Cadillac Mines, Ltd., Cadillac, Quebec

1. Rhyolite porphyry (altered aplite), BM-484

This is a light gray porphyritic rock composed of euhedral to anhedral phenocrysts of albite lying in an aphanitic groundmass of quartz, muscovite, albite, and a minor amount of calcite. The average grain diameter of the phenocrysts is 1 mm., the groundmass, 0.01-0.05 mm. A maximum of 2.6 mm. was recorded for an albite phenocryst.

The rock has been deformed, either during the end stages of crystallization or at a distinctly later period. Quartz has yielded more readily than feldspar and has been

granulated. The latter mineral has been bent and fractured. Where displacement occurs, fine-grained quartz and muscovite have flowed into the fractures in the feldspar.

The euhedral character of many of the phenocrysts and their grain size indicate that the rock was originally a porphyry, rather than an aplite*.

2. Greenstone (volcanic sediments), BM-485

This is a dark green to black rock, composed almost wholly of quartz and chlorite. It is thoroughly crenulated on a very fine scale. The average grain diameter lies in the range of 0.07-0.15 mm.

Glass and textures usually characteristic of volcanic rocks are absent and the term 'volcanic sediments' is not applicable from a purely petrographic standpoint. The field data indicate that this rock occurs interbedded with Precambrian lava flows and may be intimately associated with them. It may have been derived from the flows or otherwise altered from them, but this cannot be determined solely by microscopic studies. Accordingly, the more general name, greenstone, is preferred.

3. Skarn (banded iron), BM-486

This is a banded, predominantly black rock, composed principally of quartz, magnetite, hematite, and carbonate. Accessory amounts of chlorite, apatite, and sulphide complete the mineralogy. The carbonate generally occurs in veinlets. The average grain diameter lies in the range of 0.08-0.3 mm.

Group II - Lake Shore Mine, Ltd., Kirkland Lake, Ontario

1. Not studied (labelled 'basic syenite'), BM-487.

2. Altered syenite (basic syenite), BM-488

This is a greenish-gray rock composed principally of altered feldspar and altered pyroxene. The rock contains major amounts of both soda and potash; presumably two feldspars represent the unaltered material. Feldspar is deformed and to a considerable extent fractured and sericitized. Pyroxene occurs in euhedral cross sections and prismatic grains, all showing heavy pseudomorphous alterations. The pyroxene has been changed to hornblende; which, in turn, has been replaced by talc, chlorite, and calcite. Minor amounts of apatite, sulphide, and chloritized biotite complete the mineralogy.

The rock is relatively coarse-grained, having an average grain diameter of 1-5 mm.

*Note: The rock names in brackets are those given by the mines sending the rocks. In connection with the names given by Mr. Jaffe, see his explanation in the final paragraph for No. 7 of Group II.

3. Rhyolite porphyry (syenite porphyry), BM-489

This rock has a mottled appearance and shows pale green albite phenocrysts lying in a dark reddish-gray matrix. The albite phenocrysts show a rude parallelism.

The essential minerals are albite and quartz; the latter is finely distributed throughout the matrix. Minor amounts of apatite, chlorite, sulphide, calcite, and sericite complete the mineralogy. All the phenocrysts are albite or slightly zoned albite-oligoclase and show slight to moderate alteration to sericite. The groundmass is composed essentially of fine-grained feldspar and considerable quartz. The resolution of the fine-grained groundmass requires careful examination as the quartz may be easily mistaken for feldspar. Accordingly, the name rhyolite porphyry is offered in preference to 'syenite porphyry'.

The phenocrysts have an average grain diameter of 0.5-1.5 mm.; the groundmass 0.02-0.05 mm.

4. Rhyolite porphyry (syenite porphyry), BM-490

This rock is very similar to BM-489.

5. Red rhyolite porphyry (red syenite), BM-491

This rock has a mottled appearance and shows light grey to green albite phenocrysts lying in a pink to red matrix. The red color is probably due to hematitic stain. Microscopically, the rock is similar to BM-489. The following significant differences are noted:

- a. The rock contains some corroded quartz phenocrysts.
- b. It shows marked deformation, with granulated and fractured albite phenocrysts traversed by veinlets of sericite and quartz.
- c. It contains considerably more carbonate than BM-489.
- d. In general, it is more altered than BM-489.

6. Red rhyolite porphyry (red syenite), BM-492

This rock is very similar to BM-491.

7. Altered red rhyolite porphyry (altered syenite porphyry), BM-493

This rock is similar to BM-491 and may be considered a badly deformed and altered variant of the latter. It shows more sericite and carbonate, more granulation, and the introduction of quartz and sulphide in veinlets.

General.

In describing the rocks BM-489-493, the names rhyolite and rhyolite porphyry have been selected in preference to syenite and syenite porphyry, largely on descriptive criteria; in these instances, the presence of appreciable quartz. It is quite possible that field evidence would show that these rocks are syenites and have undergone some silicification along with other modifying factors. In BM-493, for example, there is the suggestion of introduced quartz that is different in character from the quartz observed in the groundmass of the other rocks. In the classification of complicated rocks, where field data are not available, and where the sequence of events is not obvious, the petrographer must use the mineral composition as the prime consideration.

Group III - International Nickel Company, Sudbury, Ontario

1. Rhyolite or fine-grained granite (quartzite), BM-499

This is a dark grey rock composed principally of quartz, albite, biotite, and muscovite. A smaller amount of orthoclase is present. Some of the biotite is altered to chlorite, but the rock is otherwise fresh.

The grains are anhedral and the texture is sutured. The average grain diameter is 0.2 mm. According to its mineralogy and texture, the rock appears to be a rhyolite or fine-grained granite, rather than a quartzite.

2. Rhyolite (rhyolite), BM-500

This is a dark grey rock composed essentially of quartz and biotite with lesser amounts of feldspar. The biotite is well oriented and the quartz somewhat elongated, giving the rock a microscopic foliation. Small lenses of fine-grained feldspar are oriented parallel to the foliation.

The average grain diameter lies in the range of 0.1-0.5 mm.

3. Perknite or pyroxenite (periodotite), BM-501

This a dark grey-green rock composed principally of diopside and actinolite. Minor amounts of biotite, chlorite, and sulphide are present.

The average grain diameter is 0.25 mm. and the maximum 3 mm. for a grain of actinolite.

Olivine was not observed, hence the name periodotite is not applicable. Either perknite or pyroxenite may be used.

4. Granite (granite), BM-502

This is a normal granite of pink and grey color with sporadic black splotches. The essential components are quartz, microcline, and myrmekite, with lesser amounts of biotite. Minor amounts of sericite and chlorite are present as alteration products of feldspar and mica respectively. A moderate amount of strain and granulation was noted.

The average grain diameter lies in the range of 0.5-1.5 mm.; the maximum is 5 mm. for a grain of microcline.

5. Gabbro (norite) - BM-503

This is a mottled dark grey-green rock composed essentially of labradorite, hornblende, and biotite. Apatite and sulphide are present in minor amounts.

The rock has an ophitic texture and an average grain diameter of 1.5 mm. Hornblende and biotite occur in place of pyroxene and may have replaced this mineral. Hypersolite was not observed and the name 'norite' is therefore not applicable.

6. Metagabbro (gabbro), BM-504

This is a dark green rock composed essentially of labradorite and actinolite-hornblende. Accessory minerals include apatite, biotite, sulphide and quartz. The rock has been subjected to deformation and granulation. Elongated pockets of crushed plagioclase and ferromagnesian minerals have produced a texture approaching that of a gneiss.

The average grain diameter lies in the range of 0.08-0.3 mm.

7. Not studied (sulphide ore -- hand specimen -- no core cut) BM-505

Group IV - Sigma Mines, Bourlamaque, Quebec.

1. Diorite porphyry (diorite porphyry), BM-508

This rock is composed essentially of oligoclase, biotite, and a lesser amount of quartz. Minor amounts of andesine, albite, apatite, sulphide, magnetite-ilmenite, and sphene are present as the accessories. The plagioclase is clouded by intrusions of fine-grained epidote. Alteration to chlorite, calcite, sericite, and epidote is heavy.

The average grain diameter lies in the range of 0.05-0.15 mm., for the groundmass and 1-2 mm. for the phenocrysts.

2. Diorite porphyry (diorite porphyry), BM-509

This rock is very similar to BM-508, but contains more biotite and is less altered.

*

Summary

Throughout this entire publication, one outstanding fact must be borne in mind: Practically all the experience reported was obtained in one mine — that of Lake Shore Mines, Kirkland Lake, Ontario. All descriptive references are applicable at the epoch of the report in which they occur; conditions have since changed many of them. The conclusions outlined in the final section of this publication apply to that particular mine. They might, or might not, be applicable to others.

Lake Shore Mines has been described in some detail in Report B. It is a hard-rock gold mine, in which the country rock is very brittle. The orebodies lie in veins that are very much jointed. The mine may be described as dry, but the air is moist and, because of the explosives used underground, is quite acid. There is very little dust, and ventilation is excellent.

A further point to be kept in mind is that the opinions expressed are those of the writer. The experience on which they are based is outlined in the various reports presented, but he alone is responsible for their formulation.

* * *

The work falls naturally into three main sections:

- (1) The establishing and maintaining of a surface seismograph at Lake Shore, chiefly for the purpose of timing rockbursts that might record at Ottawa and elsewhere, furnishing data for the determination of travel time curves for seismic waves over the Canadian Shield.
- (2) The interim investigations underground, with what was at first very meagre equipment, for the purpose of finding some means of predicting rockbursts.

These include:

- (a) Strain Gauges
 - (b) Makeshift mine seismograph recording
 - (c) Microgauge measurements of bore-hole closure
 - (d) Attempts to determine frequency values for bursts and blasts
 - (e) Use of seismic survey equipment (for the purpose outlined in (d)) and also to obtain velocities of seismic waves over short underground paths and to detect any variations therein due to changes of pressure.
- (3) Experience with the microseismic method, i.e. the study of subaudible vibrations of about 1,000 c.p.s., as a means of predicting rockbursts.

The strain gauge experiments were confined to a single instrument and, while the results were encouraging the method was too cumbersome to be of much value.

The makeshift mine seismograph was gradually developed into a most useful instrument and then gave valuable service throughout the program.

The microgauge gave promise of useful application, but was abandoned in favour of the microseismic method. There was not sufficient staff to carry out both investigations and the mine officials decided to concentrate on the latter.

The frequency studies indicated that the bursts and blasts each generate a wide spectrum of seismic frequencies, the former up to 200 to 400 c.p.s. and the latter 40 to 60 c.p.s. Other mine noises, except drills, were found to generate frequencies of about 100 c.p.s. The frequency for drills was about 200 c.p.s. But all efforts to build a positively selecting filter failed. Several filters were built that helped a great deal but none was completely successful in suppressing waves from the larger blasts.

The subaudible or microseismic method was in use from about June 1942 to October 31, 1945 — the close of the program. It is the results of this method which are of major interest in the reports. Report W is based on laboratory tests of this method, carried out after the Lake Shore program was closed.

* * *

Initially, the main objective of the Observatory was to obtain data for travel-time tables. This objective was never lost sight of. Every effort was made to obtain accurate data and to have no lapse in the recording. At first, this necessitated the rigid routine and careful supervision shown in Reports A, D, and G. This was especially true in the early stages, when the servicing of the seismograph was being carried out by inexperienced

operators. As the work went on, and Gibbs and Hallick took over, this supervision was not required. All concerned were keenly interested in maintaining unfailing operation of the surface seismograph. Mr. O.E. (Ted) Andrew was equally concerned with the mine seismograph records (G-1); and, being in the geological office, did much to correlate the mine seismograph records with mining operations. A paper based on the then available travel-time data is given as Report H.

The writer was very much interested in the subaudible method, which he had suggested in 1923 (Bib. No. 47) as a means of predicting earthquakes. In January 1940, he proposed this as one of the possible means of predicting rockbursts. No effort or expense was spared by the survey engineers or the mine officials to give this method a thorough trial under the conditions obtaining at Lake Shore.

The entire program was carried out under wartime conditions of scarcities and restrictions. All recommendations made to Lake Shore Mines were approved at once and every effort was made to secure the required supplies. The influence of Mr. Blomfield was such that priorities otherwise unobtainable were given promptly. The cooperation of the U.S. Bureau of Mines and Dr. Obert was obtained at a time when conditions were most difficult.

There were, however, unavoidable delays in shipment. Many commercially built instruments, which would have saved much time and work, were simply not obtainable. However, owing to the efforts of the mine officials and the skill and ingenuity of Gibbs, the program did not suffer materially from wartime conditions, in so far as the equipment was concerned.

There was one such influence which did affect the program. Because of the war there was a lessened mining activity at Lake Shore. On the one hand, this made it easier to have periods in the mine free from disturbances due to mining; but, on the other hand, there were fewer rockbursts. The ones that did occur were (except for two in seven years) too small to record at Ottawa, and so did not help the travel-time project. Of the many smaller bursts, most occurred at or just after blasting, and did not provide any opportunity for prediction, except in a very few cases.

The first heavy burst during the program did not take place until January 29, 1943. It was in the West Pillar (Report L) and was the one outstanding case, apart from the experience in the Frood mine (J-7a), where the best deductions can be made from microseismic data. These are discussed in section L-7 and illustrated in Figure 59. The latter is based on records from high-class equipment that are quoted in full in the report indicated. The coverage was rather meagre, as only seven geophones were available at that time. Long-outstanding orders for crystals and transformers had not yet been delivered.

Of the seven geophones recording the preliminary conditions preceding the above burst only two survived. They were still the only available pick-ups when the second heavy

burst took place on March 31, 1943. Moreover, they were much too far away from the source to record any microseisms. By June 1943, the outstanding orders were filled and there were soon close to a hundred geophones completed or in the last stages of construction. From that time on, there was no lack of coverage. Unfortunately, in the succeeding and final 2 years of operation, only three small bursts that could possibly have been predicted occurred (O-4; O-5).

Throughout this very trying period, members of the survey group found strongly reinforced the conclusion that in any final, regular program of mine protection the daily check-up must be carried out by means of listening, not by recorders.

While this was recognized and stressed, they were insistent that any program adopted must be rigorously maintained, and that every possible care must be taken to record, index, and file all data that might possibly be relevant up to and through a burst or bursts within the recording range of the geophone installation, so that every factor contributing to the possible solution of the problem of prediction might be available for study and evaluation.

After the seven final months of painstaking work with the intensive seismic program (O-8), maintaining all the meticulous care to standardize equipment (L-9), ensure complete and unbroken coverage, and digest and report to all concerned all data observed, two or three very small bursts only were registered.

By this time, the entire equipment needed drastic overhaul. The mine officials decided to terminate the program on October 31, 1945. That the expected burst did occur some 6 weeks later in the very section covered by the intensive program is one of the most disappointing aspects of the matter.

*

Conclusions

The following are the writer's conclusions from the data of the entire research:

- (1) Strain gauges and bore-hole gauges give some promise of indicating increasing pressure, but their application in a mine such as Lake Shore would be cumbersome. Electric strain gauges would perhaps be of value, but the walls of all openings in this mine are so slabbed that the use of gauges would be inconclusive.
- (2) Velocity measurements are useless as pressure indicators. Pressure moves so rapidly from point to point (L-5) that it is impossible to say what path the seismic waves follow from burst or blast to the recorder. This fact, coupled with the strong probability that the paths between identical termini would vary from one test to another, and the difficulty of maintaining lines free from attack by acid-charged water (E-3) make the method of little or no value as a pressure indicator. It did prove useful in determining the peak frequencies of blasts and bursts.
- (3) It would seem to be firmly established by the experience in the mine and by the laboratory tests (Report W) that microseisms are generated by strain or compression in the rock, that they increase in number per minute with increasing pressure and that this increase becomes accelerated as the limit of strength is approached. This would seem to make then an ideal means of predicting rock-bursts. Obert has found such methods very satisfactory in some U.S. mines. Their application in Lake Shore Mines is another matter, as the following paragraphs show.
- (4) Pressure at Lake Shore moves very rapidly from point to point (L-5). As a result, a dangerous condition at a given point may pass to another part of the working before a burst occurs. A blast or burst in another section of the mine may suddenly transform a 'safe' point to a dangerous one, which again may or may not burst.
- (5) The conditions next above make the application of this method to safety procedure most hazardous. A stope is found 'dangerous' one morning, and the men are removed to work elsewhere; a day or two later it is reported 'safe', and the men are sent back. A blast or burst elsewhere suddenly shifts the pressure on the stope once more and it bursts. The mine officials are left to explain why they sent men back into a danger zone.
- (6) Microseisms with frequencies of 1,000 c.p.s. seem to be the most informative (L-7). The standard geophones were equally sensitive in pick-up when constructed to be sensitive to vibrations of 2,000 c.p.s. The

microseismims at 1,000 c.p.s cannot be recorded at distances of more than about 75 ft. in Lake Shore rock, but can be heard over the headphones up to 200 ft. or so.

- (7) It is extremely difficult to maintain sensitive equipment of the required type underground. If adequate coverage is required, the cost of installation is high and also that of maintenance for more than a few months. It required constant expert attention to keep equipment in an efficient operating condition.
- (8) In view of the conclusions above, it would seem that the only possibility of applying microseismim equipment to a safety program in a mine such as Lake Shore is that mentioned in sections M-6(H) and O-8.
- (9) The 'doming theory' seems to apply in the Lake Shore mine (B-4 & L-6). Briefly, the theory is that the pressures underground are supported by pillars* of many forms and locations. The material between pillars is supported by arches that extend back into the country rock. As pillars are removed, new arches form and strain bursts of various magnitudes occur. If and when the pressure on any pillar exceeds the strength of the rock, a burst takes place, the magnitude of which is a function of the volume of rock involved and its bursting strength. The writer's experience supports this theory so far as the Lake Shore mine is concerned. Note especially the recording from adjacent deep and shallow holes as reported in section K-9(3).
- (10) There seems to be no residual strain in the rock at Lake Shore in the sense of strain resulting from its geologic history. The almost complete absence of strain indications at many points in the mine and the distribution of the centres indicating pressure favour the conclusions of this paragraph and the preceding.
- (11) Bursts at Lake Shore generate longitudinal seismic vibrations (P-waves) that are kataseismic (having the initial movement away from the recording station and in line with the traverse from burst to recorder). In this connection see section H6; further conclusions drawn from the travel-time investigation are found throughout Report H, and are summarized in section H-7.
- (12) The writer concurs fully with Dr. Langford with respect to the desirability of establishing some organization in Canada charged with the responsibility of carrying out research on all features of rock behaviour under pressure. This should include both rocks in place and those studied under laboratory conditions.

* See footnote, p.27, for definition of 'pillar'.

BIBLIOGRAPHY

With the exception of three papers dealing with the determination of travel-times of seismic waves from Kirkland Lake rockbursts over the traverse from there to Ottawa, the publications listed below are those available at the time the rockburst research program was carried out from 1938 to 1945.

1. Adams, F. D. and Coker, E. G., An Investigation into the Elastic Constants of Rocks. Pub. Carnegie Instn. Wash., No. 46, 69 pp., 1906.
2. Adams, L. H. and Gibson, R. E., The Elastic Properties of Certain Basic Rocks and Their Constituent Minerals, Proc. Nat. Acad. Sci., Vol. 15, p. 713, 1929.
3. Adams, L. H. and Williamson, E. D., The Compressibility of Minerals and Rocks at High Pressure, J. Franklin Inst.; Vol. 195, p. 475, 1923.
4. Adams, L. H., Williamson, E. D. and Johnston, J., The Determination of the Compressibility of Solids at High Pressure, J. Am. Chem. Soc., Vol. 41, p. 12, 1918.
5. Adler, H. W., Systems and Methods of Support in Relation to the Effects of Pressure Bursts in the Crown Mines, Ltd., Eastern Section, Proc. Mine Managers Transvaal, Inc., 117-155, 1933.
6. Allen, W., Notes on Recent Observations of Remnants, J. Chem. Met. Mining Soc. S.A., Vol. 32, No. 1, Johannesburg, July, 1931.
7. Alston, B. T., Controlling Closure against Rockbursts, S.A. Min. Eng. J., Sept. 24, 1938.
8. Beringer, B., Rockbursts, Mining Mag., Vol. 38, No. 3, 149-154, London, March, 1928.
9. Bichan, W. James, Practical Stope Support in Deep Mine Workings, Can. Mining J., Vol. 60, No. 12, 799-803, Dec. 1939.
10. Birch, F., Travel Times for Shear Waves in a Granitic Layer, Bull. Seism. Soc. Amer., Vol. 28, 49-56, 1938.
11. Birch, F., The Effect of Pressure upon the Elastic Parameters of Isotropic Solids, According to Murnaghaui's Theory of Finite Strain, J. App. Phys., Vol. 9, No. 4, 279-288, 1938.
12. Birch, F. and Bancroft, D., The Effect of Pressure on the Rigidity of Rocks, J. Geol., Vol. 46, No. 1 59-87, No. 2, 113-141, 1938.
13. Birch, F. and Bancroft, D., Elasticity and Internal Friction in a long Column of Granite, Bull. Seism. Soc. Amer., Vol. 28, 243-254, 1938.
14. Birch, F. and Bancroft, D., The Elasticity of Certain Rocks and Massive Minerals, Am. J. Sci., Vol. 237, 1-6, 1939.
15. Birch, F. and Dow, R. B., Compressibility of Rocks and Glasses at High Temperatures and Pressures, Seismological Application, Bull. Seism. Soc. Amer., Vol. 47, p. 1235, 1936.

16. Birch, F. and Law, R. R., Measurement of Compressibility at High Temperatures and High Pressures, Bull. Geol. Soc. Amer., Vol. 46, p. 1219, 1935.
17. Bridgman, P. W., Compressibility of Several Rocks under High Pressures, Amer. J. Sci., Art. 6, 1924.
18. Bridgman, P. W., The Physics of High Pressure, G. Bell and Sons, Ltd., International Textbooks of Exact Science, 398 pp., London, 1931.
19. Briggs, Henry, Mining Subsidence, Edward Arnold and Co., London, 1929.
20. Buckham, A. F., Deep Mining, Bull. Can. Inst. Mining Met., No. 284, Dec., 1935.
21. Bucky, Philip B., Use of Models for the Study of Mining Problems, Am. Inst. Mining Met. Engrs., Tech. Pub., No. 425, 3-28, 1931.
22. Bucky, Philip B., Effect of Approximately Vertical Cracks on the Behaviour of Horizontally Lying Roof Strata, Amer. Inst. Mining Engrs., Contrib. 4, 1933.
23. Bucky, Philip B., Application of Principles of Similitude of Design in Mine Workings, Trans. Am. Inst. Mining Met. Engrs., 1934, 25-30, 1934.
24. Bucky, Philip B. and Sinclair, D., Photo-elasticity and its Application to Mine-pillar and Tunnel Problems, Pub. Amer. Inst. Min. Metal. Eng., Tech. No. 1140, Jan., 1940.
25. Bucky, Philip B., Solakian, A. G. and Baldwin, L. S., Centrifugal Method of Testing Models, Civil Eng., New York, 1935.
26. Bucky, Philip B. and Taborelli, R. V., Effects of Immediate Roof Thickness in Longwall Mining, as Determined by Barodynamic Experiments, Trans. Am. Inst. Mining Engrs., No. 130, p. 314, 1938.
27. Bucky, Philip B. et. al., Rockbursts (a symposium). Am. Inst. Mining Met. Engrs., Tech. Pub., No. 1468, 56 pp., 22 fig., New York, May, 1942.
28. Chilton, J., Notes on the Removal of a Vertical Pillar, J. Chem. Met. Mining Soc. S.A., Johannesburg, June, 1918.
29. Christian, J. D., Rockbursts at the Teck-Hughes Mines, Can. Mining Met. Bull., No. 331, 550-567, 1939.
30. Christian, J. D., Rockbursts in the Kirkland Lake Area, Trans. Can. Inst. Mining Met., Vol. 42, Nov., 1939.
31. Claggett, T. H., On the Merit of Systematic Pillar Drawing in Preventing Cracks in an Upper Seam, Am. Inst. Mining Engrs., (Ground Movement and Subsidence Committee Report), Feb., 1923.
32. Cleland, R. H., Rock Temperatures and Some Ventilation Conditions in the Mines of Northern Ontario. Bull. Can. Inst. Mining Met., 379-407, April, 1933.
33. Crane, W. R., Mining Methods and Practices in the Michigan Copper Mines, U.S. Bur. Mines, Bull., No. 306, Washington, 1929.
34. Crane, W. R., Rockbursts in the Lake Superior Copper Mines, Keweenaw Point, Michigan, U.S. Bur. Mines, Bull., No. 309, 1929.
35. Crane, W.R., Subsidence and Ground Movement in the Copper and Iron Mines of the Upper Peninsula, Michigan, U.S. Bur. Mines, Bull., No. 295, 20 pp., 1929.

36. Crane, W. R., Essential Factors Influencing Subsidence and Ground Movement, U.S. Bur. Mines, Infor. Cir., No. 6501, 1931.
37. Crowle, P. J., Notes on Ground Movements and Methods of Support in Deep Mining, Kolar Gold Fields, Min. Metal. Soc. Bull., No. 22, 1927.
38. Crowle, P. J., Ground Movements and Methods of Support in Deep Mining, Kolar Gold Fields, Trans. Inst. Mining Met., Vol. 40, 77-141, 1930-31.
39. Dinsdale, J. R., Ground Failure around Excavations, Kolar Gold Fields, Trans. Inst. Mining Met., Vol. 46, 673-700, 1936-1937; Bull. Inst. Mining Met., No. 390, 1937.
40. Donald, Douglas D., A Discussion of the Rockburst Problem, A Thesis submitted for a Bachelor's degree in Geological Engineering from Princeton University. Private Circulation, 80 pp., 23 fig., bib., 1943.
41. Gane, P. G., Earth Tremors on the Rand, J. Chem. Met. Mining Soc. S.A., Johannesburg, Oct., 1939. A lengthy review appears on pp. 49-51 of Mining Mag., Vol. 62, No. 1, London, Jan., 1940.
42. Gray, C. J., Some Mining Problems on the Witwatersrand, J. Chem. Met. Mining Soc. S.A., August, 1924.
43. Gray, C. J., Rockbursts: The Effect of Crush Burst Movements on Stope Remnants and Workings in Their Vicinity, J. Chem. Met. Mining Soc. S.A., Vol. 32, 226-240, 1931-32.
44. Grime G. and Eaton, J. E., The Determination of Young's Modulus by Flexural Vibrations, Phil. Mag., Vol. 23, p. 96, 1937.
45. Hall, R. D., On the Mechanics of Subsidence from Mining, Am. Inst. Mining Engrs., (Report of Ground Movement and Subsidence Committee), Feb., 1923.
46. Hocking, W. T., Notes on Rockbursts in the Nundydroog Mine, Kolar Gold Fields, Mining Met. Soc. Bull., Vol. 8. No. 40, 69-81, 1936.
47. Hodgson, Ernest A., A Proposed Research into the Possibility of Earthquake Prediction, Bull. Seism. Soc. Amer., Vol. 13, No. 3, 100-104, Sept., 1923.
48. Hodgson, Ernest A., Recent Developments in Rockburst Research at Lake Shore Mines, Can. Mining Met. Bull., No. 377, 313-324, 11 fig., Sept., 1943.
49. Hodgson, Ernest A., Rockburst Research at Lake Shore Mines, Can. Mining Met. Bull., No. 397, 267-269, May, 1945. Reported also in Mining Mag., Vol. 70, No. 2, 116-118, 1 fig., London, Feb., 1944.
50. Hodgson, John H., Analysis of Travel Times from Rockbursts at Kirkland Lake, Ontario, Bull. Seism. Soc. Amer., Vol. 37, 5-17, 1947.
51. Hodgson, John H., A Seismic Survey in the Canadian Shield, I. Refraction Studies based on Rockbursts at Kirkland Lake, Ontario, Publs. Dom. Obs., Vol. 16, 113-163, 1953.
52. Hodgson, John H., A Seismic Survey in the Canadian Shield, II: Refraction Studies Based on Timed Blasts, Publs. Dom. Obs., Vol. 16, 169-181, 1953.
53. Hopkins, Harold, Faulting at Wright-Hargreaves Mine, with Notes on Ground Movements, Trans. Can. Inst. Mining Met., Vol. 43, 685-707, 1940.
54. Horwood, C. B., Prevention of Rockbursts on the Rand, S.A. Mining Eng. J., Johannesburg, March 11, 1939.

55. Hubbert, M. K., Theory of Scale Models as Applied to the Study of Geologic Structure, Bull. Geol. Soc. Amer., Vol. 48, 1459-1520, 1937.
56. Ide, J. M., Some Methods for Determination of Young's Modulus, Rev. Sci. Insts., Vol. 6, p. 296, 1935.
57. Ide, J. M., An Experimental study of the Elastic Properties of Rocks, J. Geol. Vol. 1, p. 347, 1936.
58. Ide, J. M., Comparison of Statically and Dynamically Determined Young's Modulus of Rocks, Proc. Nat. Acad. Sci., Vol. 22, p. 81, 1936.
59. Ide, J. M., The Elastic Properties of Rocks: A Correlation of Theory and Experiment, Proc. Nat. Acad. Sci., Vol. 22, p. 482, 1936.
60. Jaquet J. B., Explosive Rock, Eng. Mining J., Vol. 79, 605-606, March 30, 1905.
61. Jeppe, C. W. Biccard, Review of the Rock Pressure Problem, J. Chem. Met. Mining Soc. S.A., Vol. 44, Nos. 1 and 2, Johannesburg, July-August, 1943.
The paper, without the discussion section which followed, appeared in Can. Mining J., Vol. 64, No. 12, 788-792, Dec., 1943, with the title: Rock Pressure Problem: Cause, Control and Prediction.
62. Joseph, E. H. A., Rockbursts: The Mechanism of Crush Bursts, J. Chem. Met. Mining Soc. S.A., Vol. 39, No. 5, 114-131, Johannesburg, Nov. 1938.
A second paper, with the same title and by the same author, appeared in the same journal, Vol. 40, No. 7, 243-257, Jan., 1940.
63. Joseph, E. H. A., Rockbursts: The Mechanism of Crush Bursts, Bull. Inst. Mining Met., No. 411, 26 pp., Dec., 1938.
64. Keeley, D. E., Guniting at the McIntyre Mine, Trans. Can. Inst. Mining Met., Vol. 37, 316-340, 1934.
65. Landsberg, H., Some Observations on Mine-roof Action, Trans. Am. Inst. Mining Met. Engrs., (Coal Division), Vol. 130, 358-370, 1938.
66. Langford, George B., The Rockburst Problem, Can. Mining Met. Bull., No. 348, 169-182, April, 1941.
67. Larsen, E. A. and Bridgman, P. W., Shearing Experiments on Some Selected Minerals, Am. J. Sci., Vol. 36, 81-94, 1938.
68. Leet, L. D., Velocity of Elastic Waves in Granite and Norite, Physics, Vol. 4, 375-385, Oct., 1933.
69. Leet, L. D., Travel Times for New England, Bull. Seism. Soc. Amer., Vol. 28, No. 1, 45-48, 1938.
70. Leet, L. D., Longitudinal Velocities in Some Weathered and Unweathered Carboniferous Rocks, Bull. Seism. Soc. Amer., Vol. 28, No. 3, 163-168, 1938.
71. Leet, L. D. And Ewing, W. M., Velocity of Elastic Waves in Granite, Physics, Vol. 2, No. 3, 160-173, 1932.
72. Lindsay, J. K., Support by Granite Masonry Walls in Mysore Mine, Kolar Gold Fields, Mining Met. Soc. Bull., Vol. 6, No. 33, 1932.
73. Love, A. E. H., A Treatise on the Mathematical Theory of Elasticity, Cambridge University Press.

74. McNair, F. W., On the Dome Theory, Am. Inst. Mining Engrs., (Report of Ground Movement and Subsidence Committee), Feb., 1923.
75. Mindlin, R. D., Stress Distribution around a Tunnel, Proc. Am. Soc. Civil Engrs., New York, April, 1939.
76. Morrison, R. G. K., Notes on a Rockburst in the Ooregum Mine, Kolar Gold Fields, Mining Met. Bull., No. 33, 1932.
77. Morrison, R. G. K., Notes on Witwatersrand Mining Practice, Kolar Gold Fields, Mining Met. Bull., Vol. 50, No. 38, 1935.
78. Morrison, R. G. K., Points of View on the Rockburst Problem, Trans. Can. Inst. Mining Met., Vol. 42, 443-460, Aug., 1939.
79. Morrison, R. G. K., Report on the Rockburst Situation in Ontario Mines, Can. Mining Met. Bull., No. 361, 225-272, 18 fig., May, 1942.
80. Moulton, H. G., Earth and Rock Pressures, Am. Inst. Mining Engrs., Vol. 63, 1920.
81. Obert, Leonard, Measurement of Pressures on Rock Pillars in Underground Mines, U.S. Bur. Mines, Rep. Invest., No. 3444, 15 pp., bib., April, 1939.
82. Obert, Leonard, Measurement of Pressures on Rock Pillars in Underground Mines, U.S. Bur. Mines, Rep. Invest., No. 3521, 11 pp., June, 1940.
Reprinted in Eng. Mining J., Vol. 142, No. 7, 52-55, July, 1941.
83. Obert, Leonard, Use of Subaudible Noises for Prediction Rockburst, U.S. Bur. Mines, Rep. Invest., No. 3555, 4 pp., Jan., 1941.
Reprinted in Can. Mining J., Vol. 62, No. 6, 371-372, June, 1941.
84. Obert, Leonard and Duvall, Wilbur, Use of Subaudible Noises for the Prediction of Rockbursts, U.S. Bur. Mines, Rep. Invest., No. 3654, 22 pp., July, 1942.
Reprinted in Mining Mag., Vol. 67, 114-115, London, Sept., 1942.
85. Obert, Leonard and Duvall, Wilbur, Microseismic Method of Predicting Rock Failure in Underground Mining: Part I, General Method, U.S. Bur. Mines, Rep. Invest., No. 3797, 7 pp., Feb., 1945.
86. Obert, Leonard and Duvall, Wilbur, Microseismic Method of Predicting Rock Failure in Underground Mining: Part II, Laboratory Experiments, U.S. Bur. Mines, Rep. Invest., No. 3803, 14 pp., March, 1945.
87. Obert, Leonard, Windes, S. L. and Duvall, Wilbur, Standardization Tests for Determining the Physical Properties of Mine Rock, U.S. Bur. Mines, Rep. Invest., No. 3891, 67 pp., extensive bib., August, 1946.
88. Palmer, R. E., Observations on Ground Movement and Subsidences at Rio Tinto Mines, Spain, Trans. Am. Inst. Mining Engrs. Vol. 91, 165-185; Tech. Pub., No. 271, 1930.
89. Pierce, C. A., Convergence of Roof and Floor in the Mines of the United States Potash Company, Am. Inst. Mining Engrs., Tech. Pub. No. 985, Nov., 1938.
90. Ranson, E. C., Mining to Depth, J. Chem. Met. Mining Soc. S.A., Vol. 35, No. 1, Johannesburg, Aug., 1934.

91. Rice, G. S., Some Problems in Ground Movement and Subsidence, Trans. Am. Inst. Mining Met., Vol. 69, p.374, 1923.
92. Richards, T. C., On the Elastic Constants of Rocks with a Seismic Application, Proc. Phys. Soc. London, Vol. 45, p. 70, 1933.
93. Richardson, A., Mine Subsidence, J. Met. Mining Soc. S.A., Vol. 7, No. 9, 1907.
94. Rickard, T. A., Air Blasts in Mines, Eng. Mining J., Vol. 116, No. 21, p. 900, 1923.
95. Robertson, A. F., Rockbursts at Wright-Hargreaves Mine, Trans. Can. Inst. Mining Met., Vol. 42, 583-592, 1939; and in Bull.No. 332, Dec., 1939.
96. Robson, W. T., Lake Shore Geology, Bull. Can. Inst. Mining Met., No. 287, 99-141, March, 1936.
97. Robson, W. T., Adamson, J. C. and Selnes, W. E., Rockbursts at Lake Shore Mines, Trans. Can. Inst. Mining Met., Vol. 43, 7-30, 1940; and in Bull. No. 333, Jan., 1940.
98. Sano, H., Experiments on Rocks for Elucidating Rock Pressure Problems, Mem. Ryojun Col. Eng. (Manchuria), Inouye Commemoration Volume, p. 261, 1934.
99. Sinclair, W. E., Rockbursts - Their Cause and Prevention, J. Chem. Met. Mining Soc. S.A., Vol. 37, 4-10, Johannesburg, July, 1936.
100. Smeeth, W. F., Air Blasts and Quakes on the Kolar Gold Field, Mysore Geol. Dept., Bull. No.2, 1904.
101. Smith, G. H. and Selby, Paul, System Packing Underground at the Terreira Deep Mine, J. Chem. Met. Mining Soc. S.A., Johannesburg, July, 1917.
102. Spaulding, J., Description of a Rockburst, Kolar Gold Fields, Mining Met. Soc. Bull., Vol. 6, No. 33, 78-81, June-December, 1932.
103. Spaulding, J., Theory of Rock Pressure, Kolar Gold Fields Mining Met. Soc. Bull., Vol. 8, No. 41, 153-171, 1935-1937.
104. Spaulding, J., The Theory and Practice of Ground Control (Kolar Gold Fields), Trans. Inst. Mining Met. Engrs. 1937-38; and Bull.No. 397, New York, 1937, with discussions printed in No. 398, Nov., 1937 and in No. 404, May, 1938.
105. Sugihara, T. and Sezawa, K., Stresses in Country Rock around a Vertical or an Inclined Circular Shaft, J. Fac. Eng., Tokyo Univ., Vol. 20, No. 5, June, 1932.
106. Swift, W. H., Determination of the Modulus of Elasticity by Dynamical Methods, Phil. Mag., Vol. 2, p. 351, 1926.
107. Taylor, C. B., The Development of Systematic Packing at the Mysore Mine, Kolar Gold Fields Mining Met. Soc. Bull., Vol. 3, No. 17, 1925.
108. Thorlund, J., Notes on Some Aspects of Mining at Depth, J. Chem. Met. Mining Soc. S.A., 42-54, Johannesburg, Sept., 1928.
- Tufty, B., Kolar Gold Field Mines--Rockbursts Feature at all Levels, Plastic Flow at Great Depths. Can. Mining J., Nov. 1957.
109. Visser, W. F., Extraction of a Shaft Pillar under Maximum Strain, J. Chem. Met. Mining Soc. S.A., Vol. 38, No. 4, Johannesburg, 1937.
The discussion of the above paper appeared in the same Journal for Oct., 1937. The author's reply to this discussion was published in Vol. 38, No. 5, 138-145, Nov., 1938.

110. Weiss, O., The Theory of Rockbursts and the Possibilities of Geophysical Methods of Predicting Rockbursts on the Producing Mines of the Witwatersrand, J. Chem. Met. Mining Soc. S.A., Vol. 38, No. 7, 273-329, Jan., 1938.
The discussion and the author's reply thereto was published in Vol. 39, No. 7, 188-197, Jan., 1939.
111. Weiss, O., Experiments on the Fracturing of Witwatersrand Quartzites under Direct Pressure, J. Chem. Met. Mining Soc. S.A., Vol 41, No. 9, 355-363, 6 fig., bib., Johannesburg, March, 1941.
112. Weiss, O., The Causes of Rockbursts, S.A. Min. Eng. J., Vol. 53, Part 2 (No. 2592), pp. 103, 105 and 107, Johannesburg, Oct. 3, 1942.
A review of this important paper appears in the Mining Digest section of Mining Mag., Vol. 67, 337-340, London, Dec., 1942.
113. Weldon, L. S., Mining Methods and Practices at Lake Shore, Bull. Can. Inst. Mining Met., No. 287, 142-202, March, 1936.
114. Weldon, L. S. and Robson, W.T., Mining Methods at Lake Shore, Trans. Can. Inst. Mining Met. Engrs., Vol. 39, 1936.
115. Witwatersrand Rockburst Committee, "Report for 1924". Published in 1925 by Cape Times, Ltd., Government Printers, Cape Town, S.A. Price 5s 6d 65 pp.
A similar report, published by the Association of Mine Managers of the Transvaal, is entitled: "Some Aspects of Deep Level Mining on the Witwatersrand, with Special Reference to Rockbursts", 198 pp., June, 1933.
116. Yamaguti, S., On Stresses around a Horizontal Circular Hole in a Gravitating Elastic Solid, J. Civil Eng. Soc. Japan, Vol. 15, 291-303, 1929.
117. Zisman, W. A., Young's Modulus and Poisson's Ratio with Reference to Geophysical Applications, Proc. Nat. Acad. Sci., Vol. 19, p. 653, 1933.
118. Zisman, W.A., Compressibility and Anisotropy of Rocks at and Near the Earth's Surface, Proc. Nat. Acad. Sci., Vol. 19, p. 666, 1933.
119. Zisman, W. A., A Comparison of Statically and Seismologically Determined Elastic Constants of Rocks, Proc. Nat. Acad. Sci., Vol. 19, p.680, 1933.
120. Zisman, W. A. and Ide, J. M., Comparison of Statically and Dynamically Determined Young's Modulus of Rocks, Proc. Nat. Acad. Sci., Vol. 22, p. 81, 1936.

I L L U S T R A T I O N S

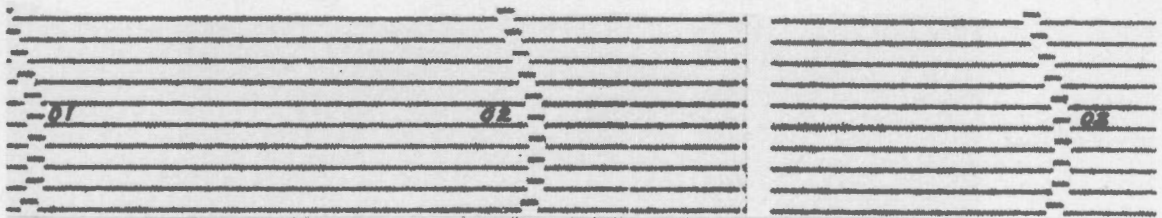
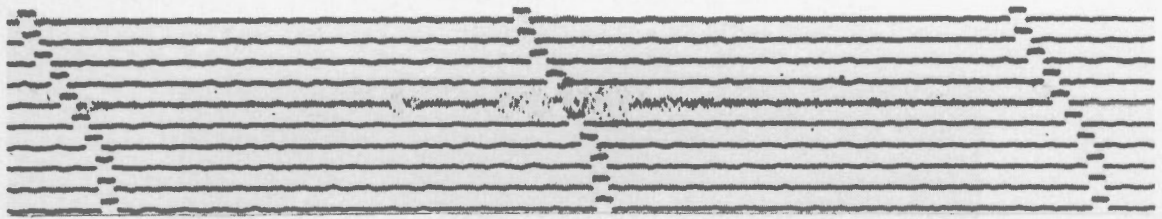

Fig. 1 Ottawa Short-period Benioff Record of Lake Shore Burst of December 27, 1938.

Fig. 2 Ottawa Short-period Benioff Record of Blast near New Haven, Conn. (40,000 lbs. of dynamite)

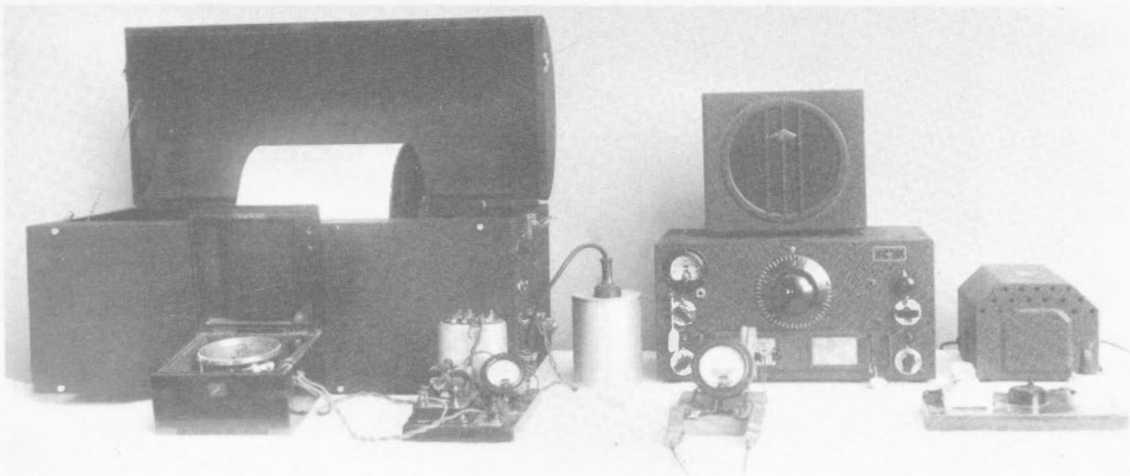

Fig. 3 Kirkland Lake Seismograph Equipment, 1939.

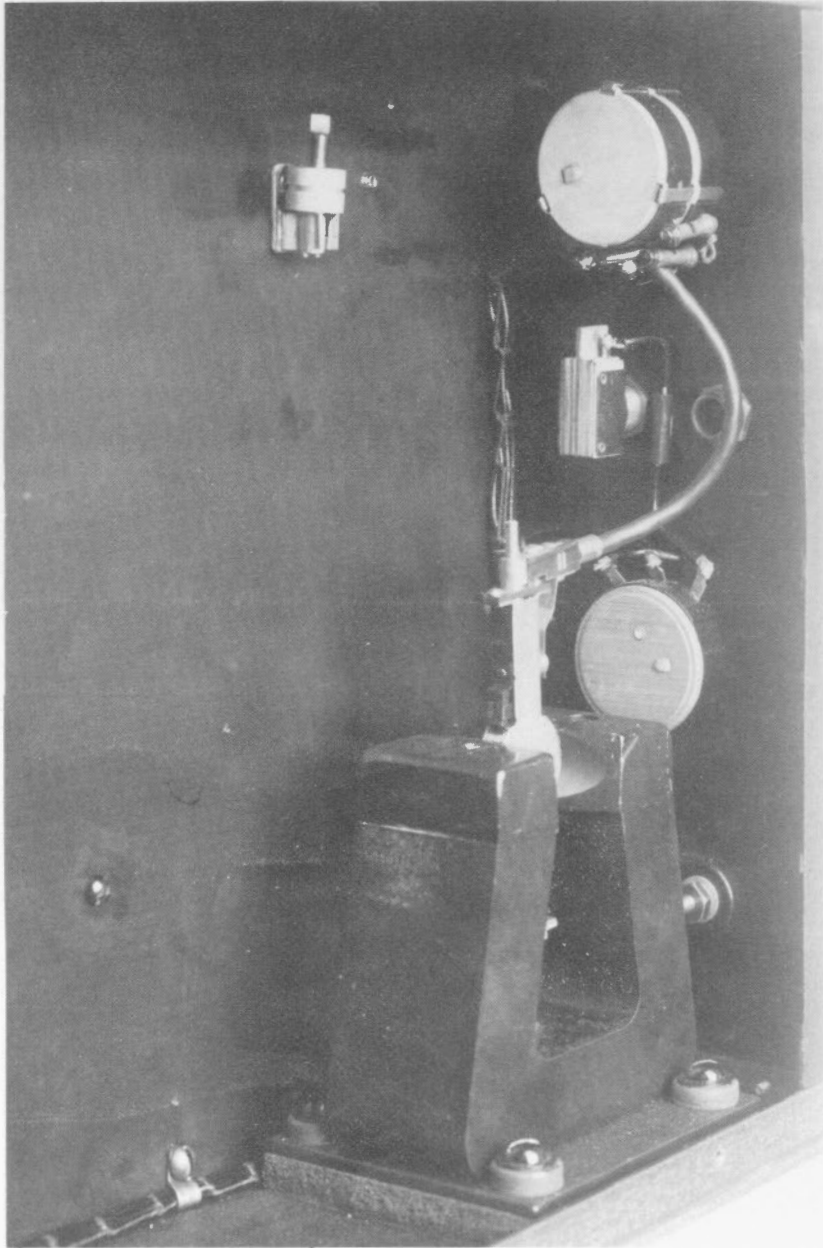

Fig. 4 Galvanometer Assembly, Surface Seismograph.

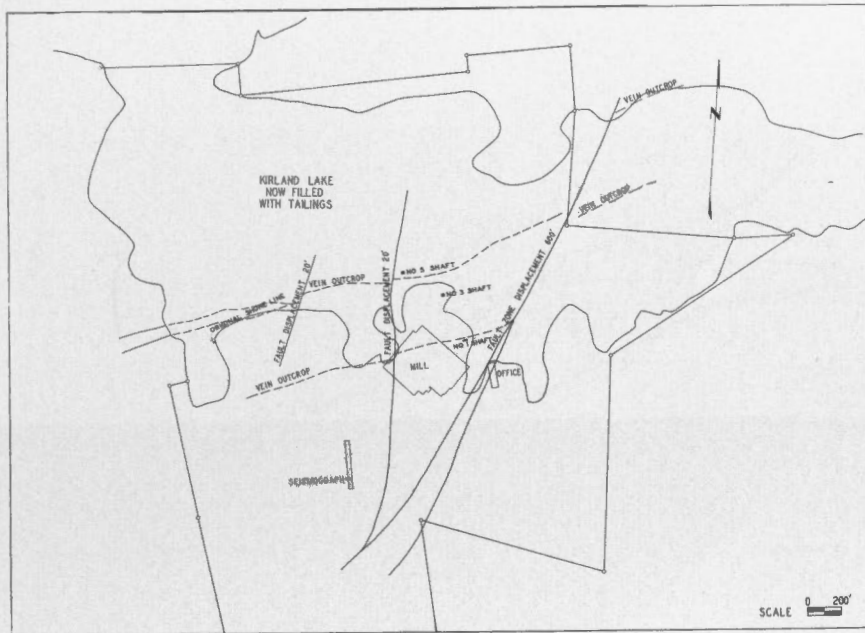

Fig. 5 Plan of Lake Shore Mines, Kirkland Lake.

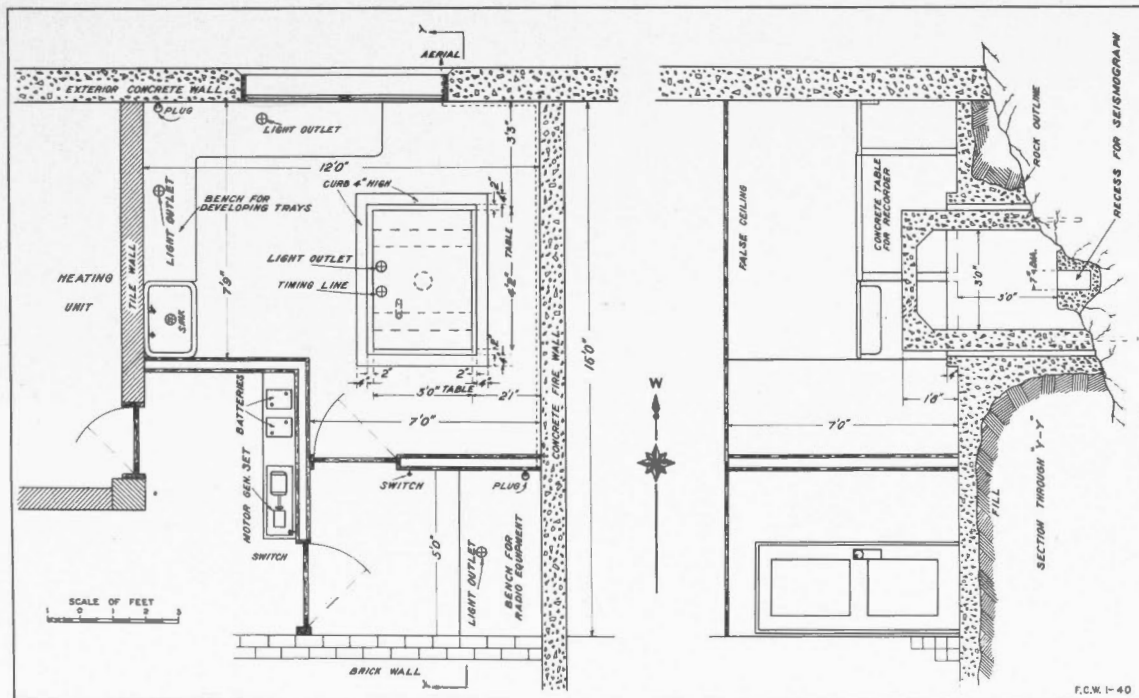

Fig. 6 Surface Seismograph Recording and Developing Room.

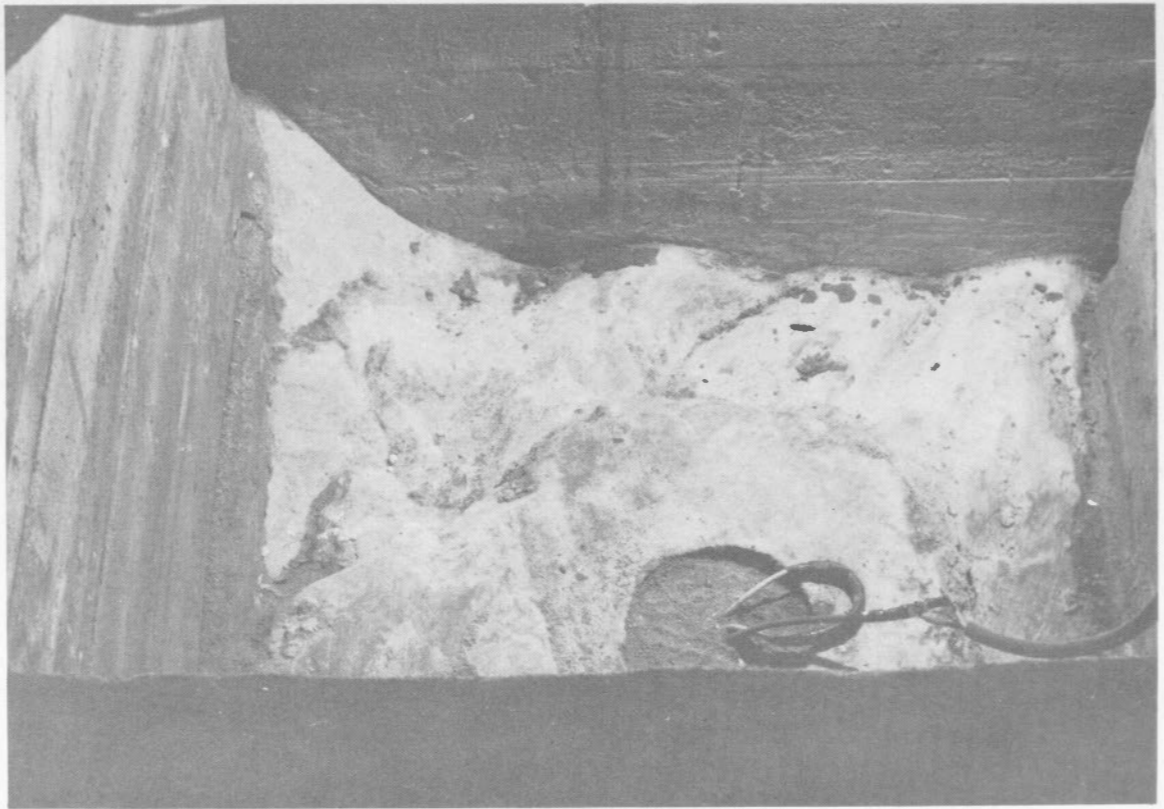

Fig. 7 Seismograph Emplacement

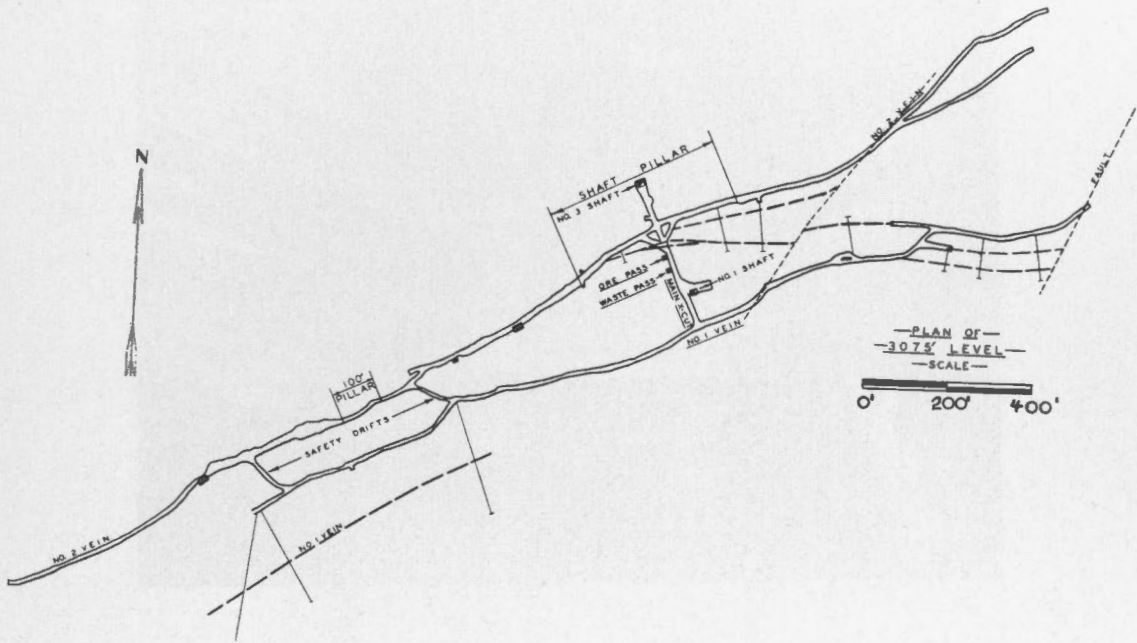

Fig. 8 Plan of 3075-ft. Level, Lake Shore Mines.

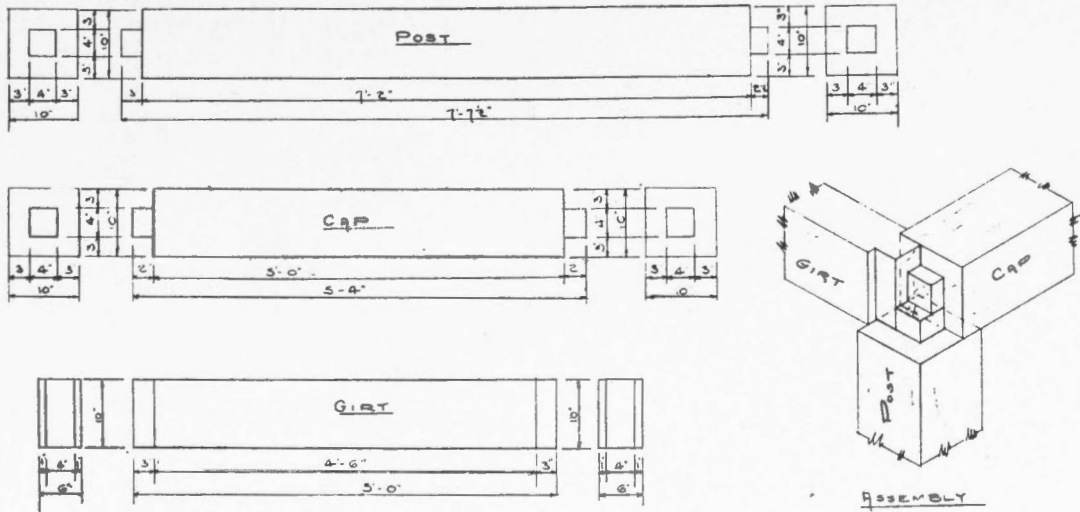

Fig. 9 Detail: Square-set Timbering.



Fig. 10 Beam Broken by End Thrust.



Fig. 11 Safety Crosscut.

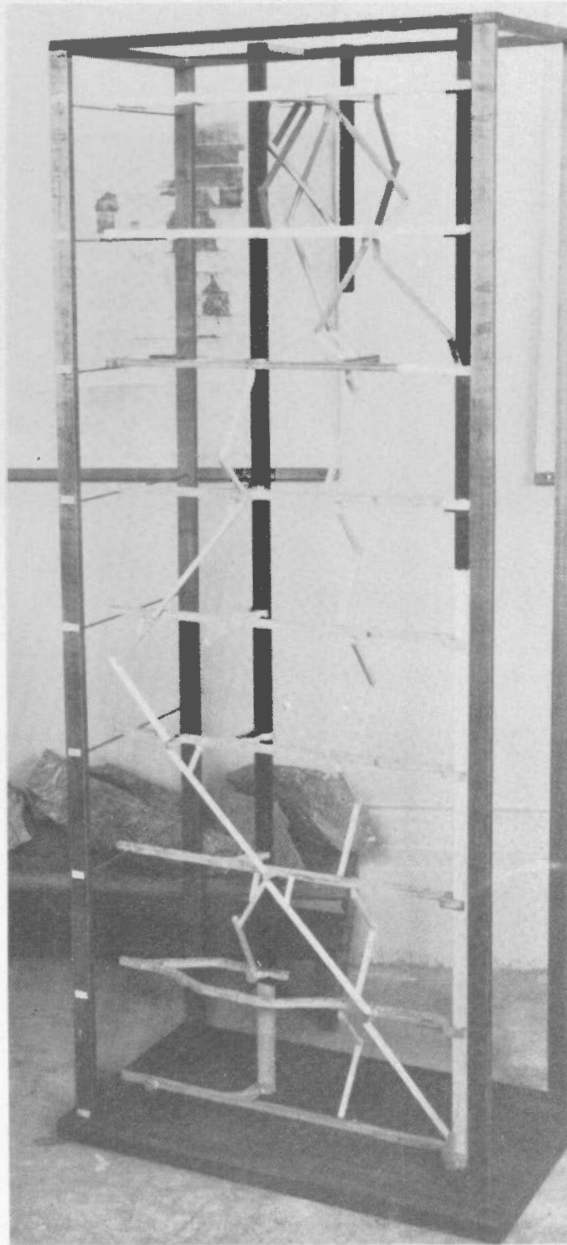

Fig. 12 Model of Ore Passes: 4325 to 5450-ft. Levels

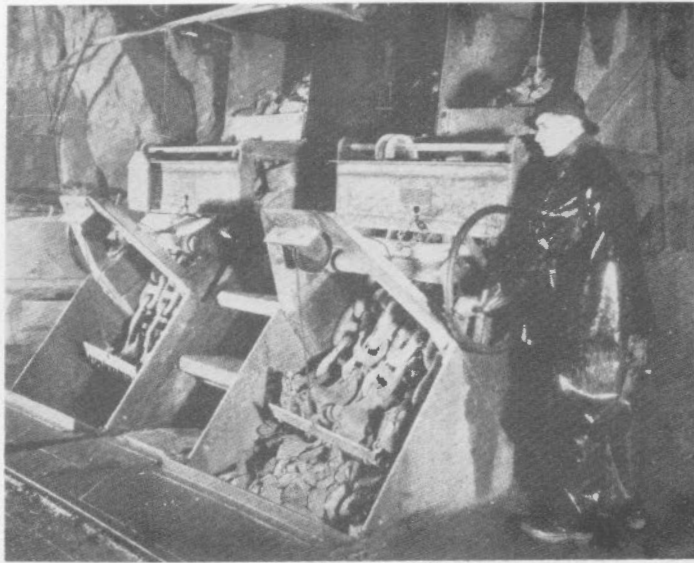

Fig. 13 Loading Pocket on 2950-ft Level, Showing Cramp Gates.

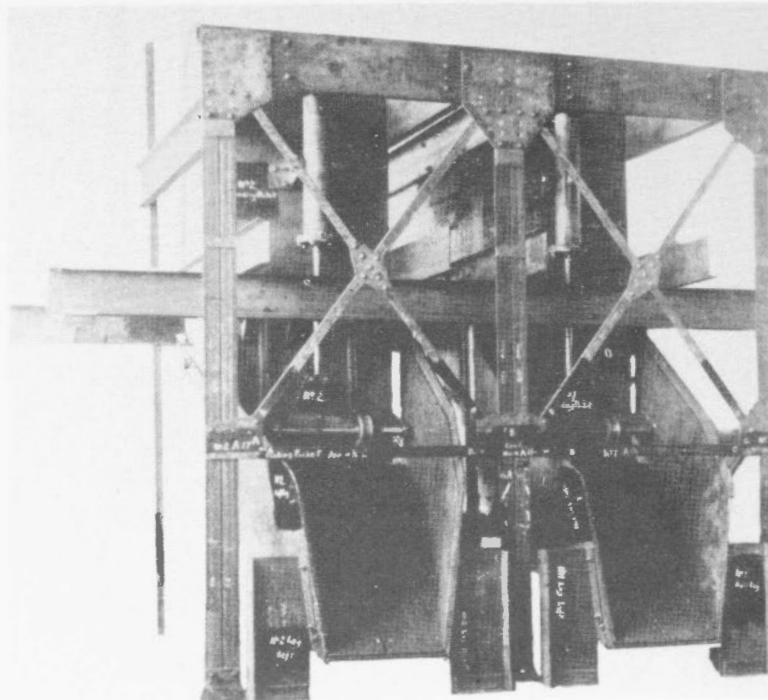

Fig. 14 Loading Pocket at Discharge Bins.

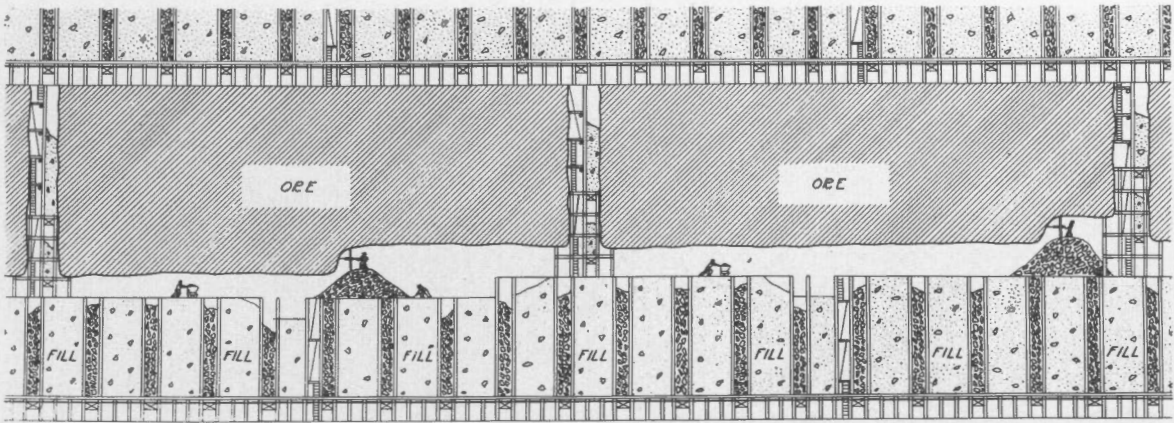

Fig. 15 Horizontal Cut-and-fill, Open Stope

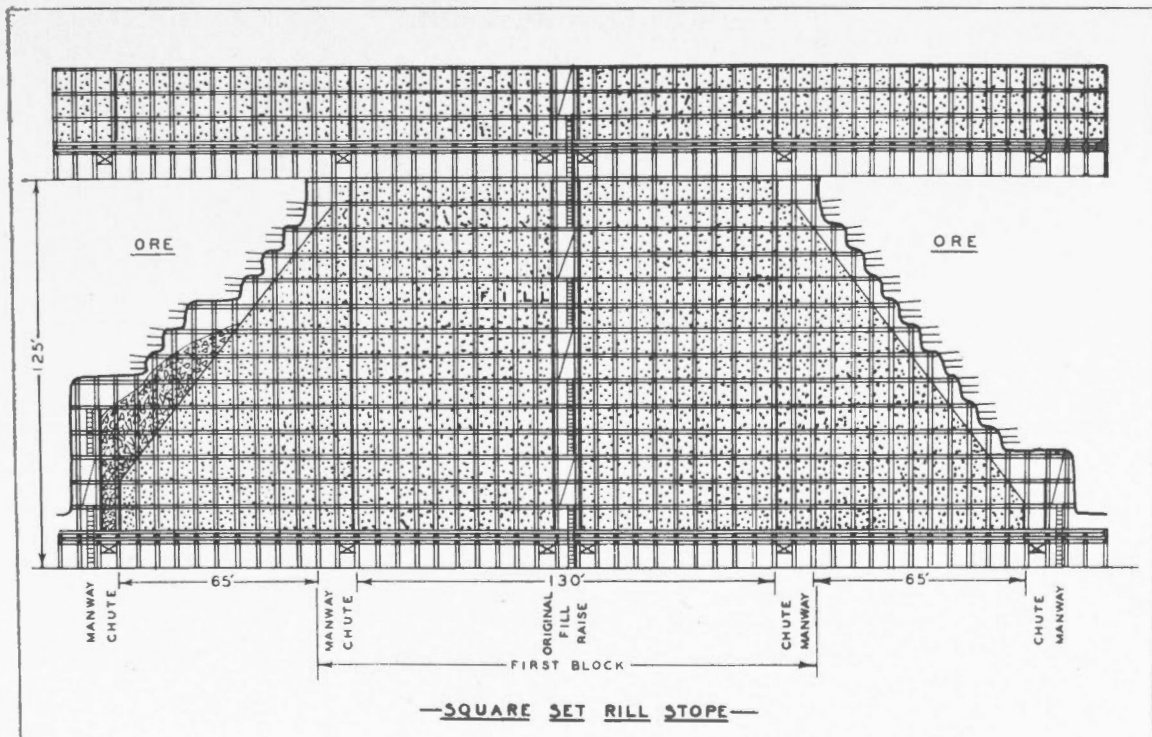

Fig. 16 Square-set Rill Stope.

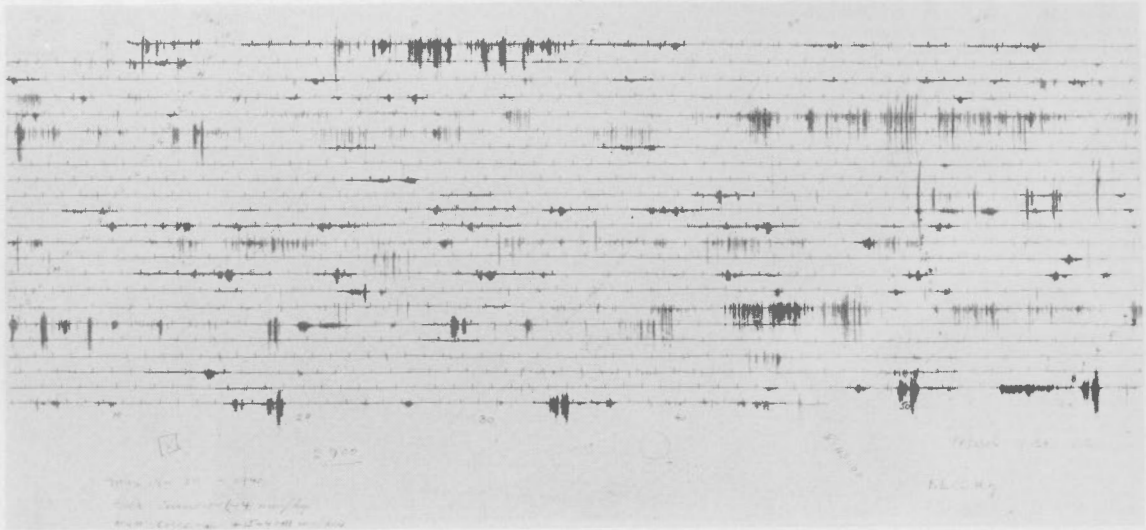

Fig. 17 Record on Hollinsworth Recorder with Brush Crystal Detector
(2950-ft. level)



Fig. 18 Interior Heiland Geophone, Mine Seismograph.

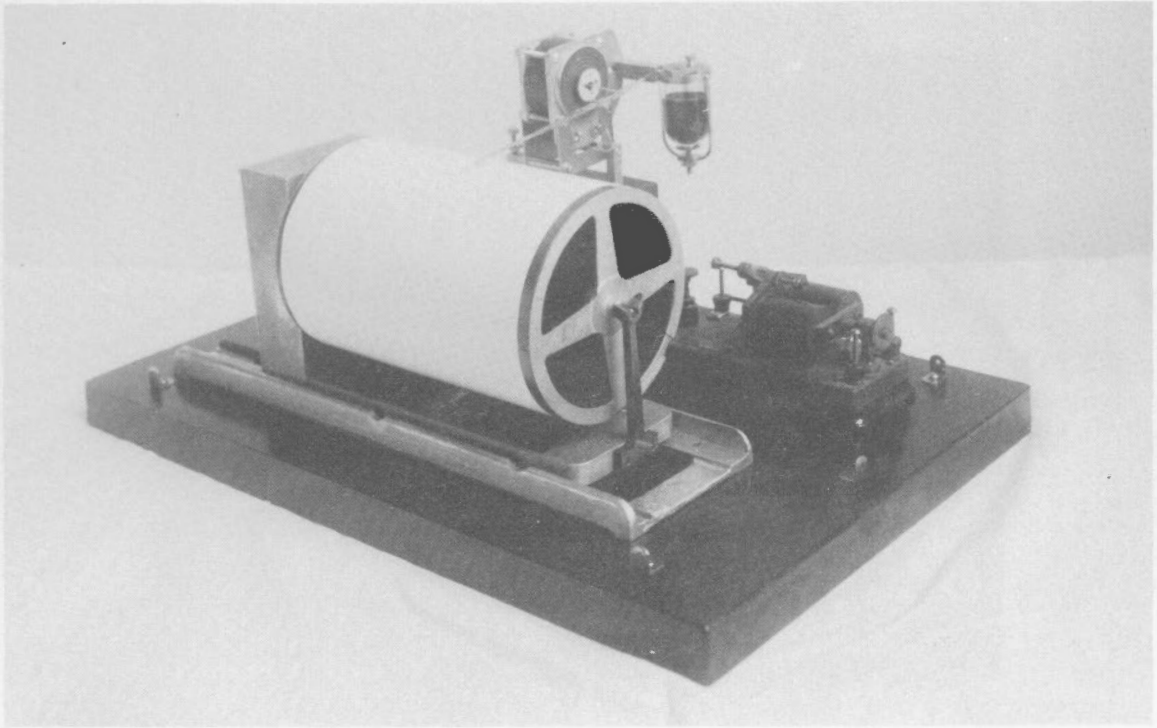

Fig. 19 Hollinsworth Recorder.

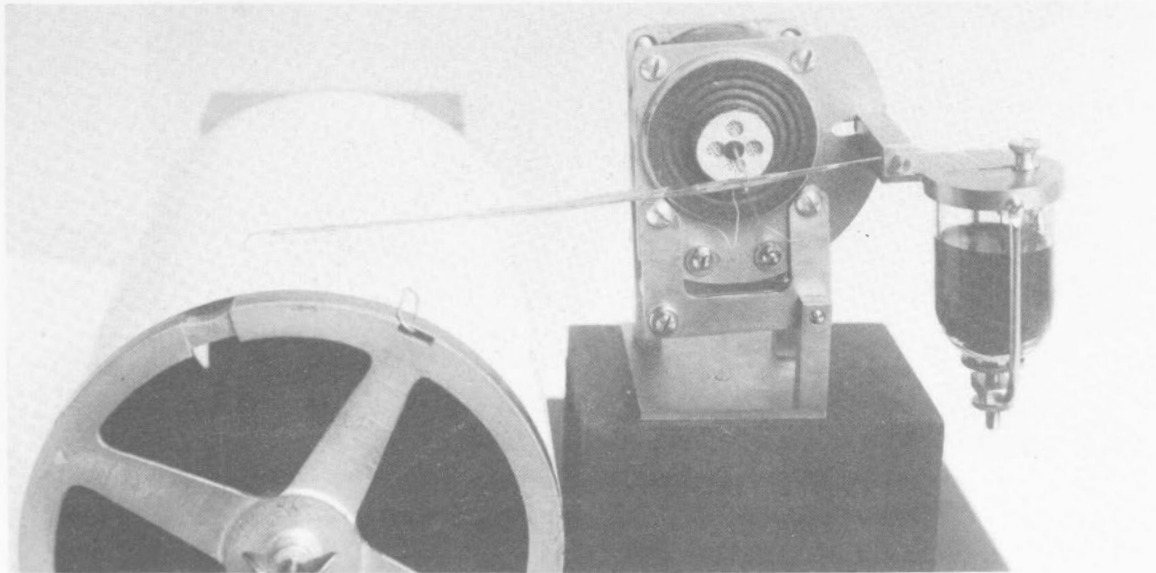

Fig. 20 Hollinsworth Recorder (pen detail).

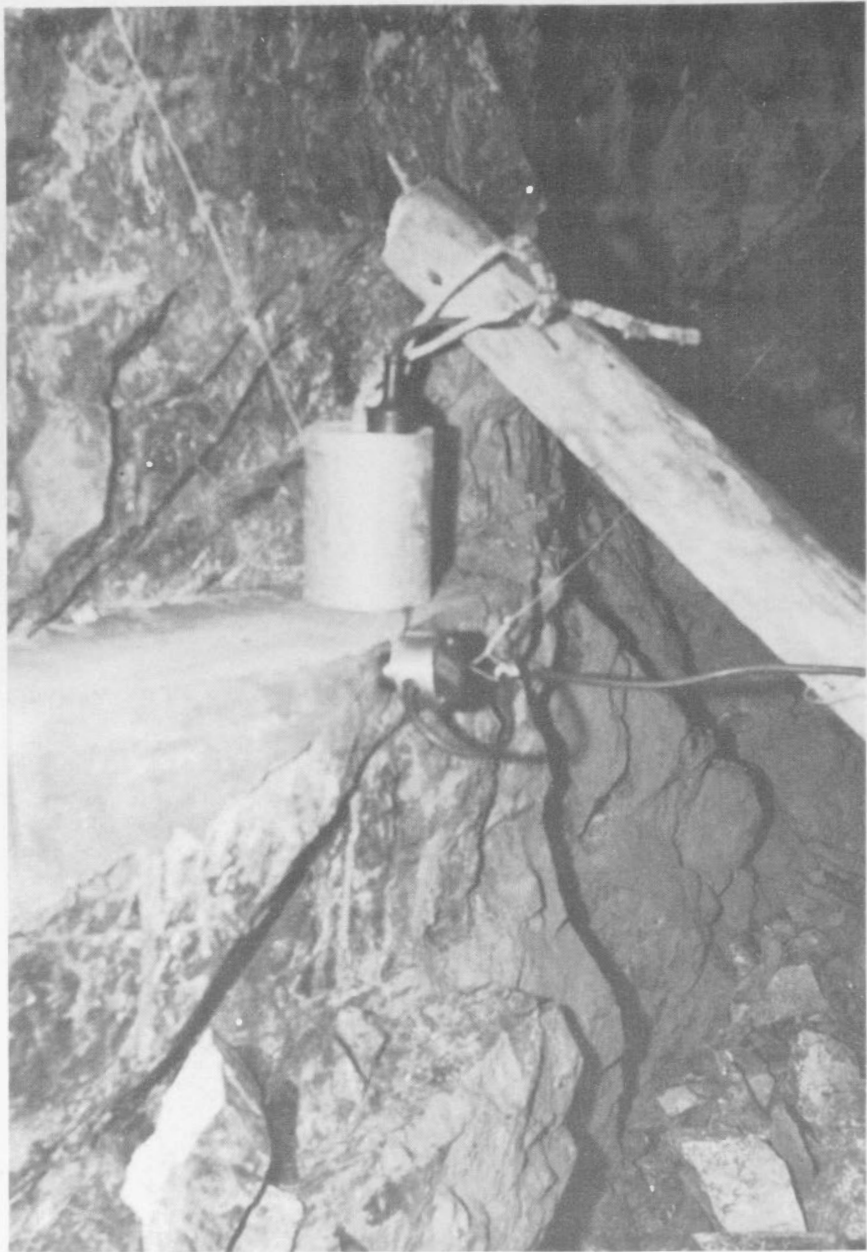

Fig. 21 Heiland Geophone and Crystal Detector (3950-ft. Level).

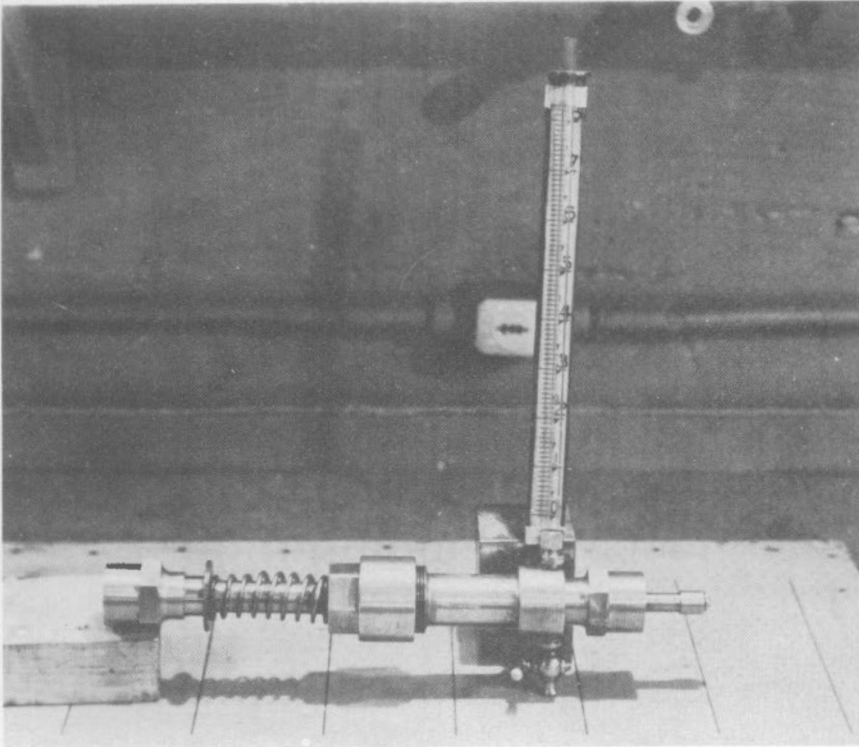

Fig. 22 Hydraulic Strain Gauge

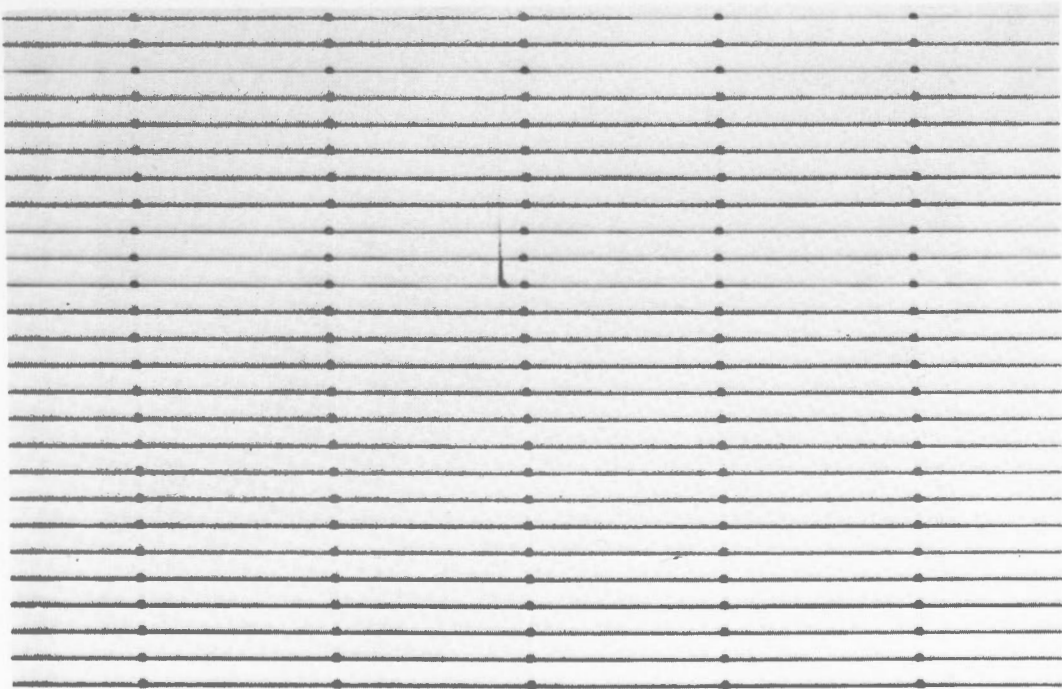

Fig. 23 Rockburst Record on Improved Surface Recorder.

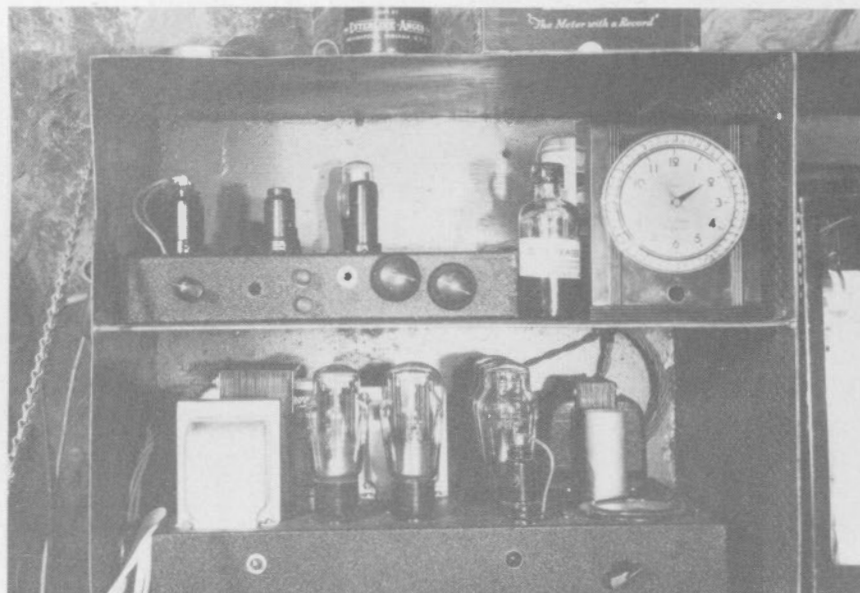

Fig. 24 Amplifier-Timer-Recorder: Mine Seismograph.

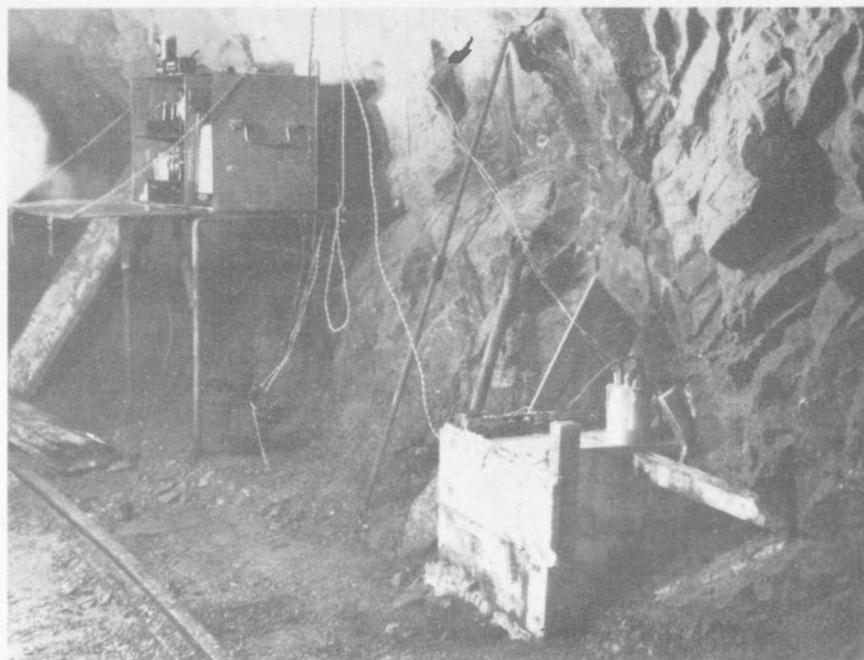

Fig. 25 Mine Seismograph Set-up (3052 Crosscut).

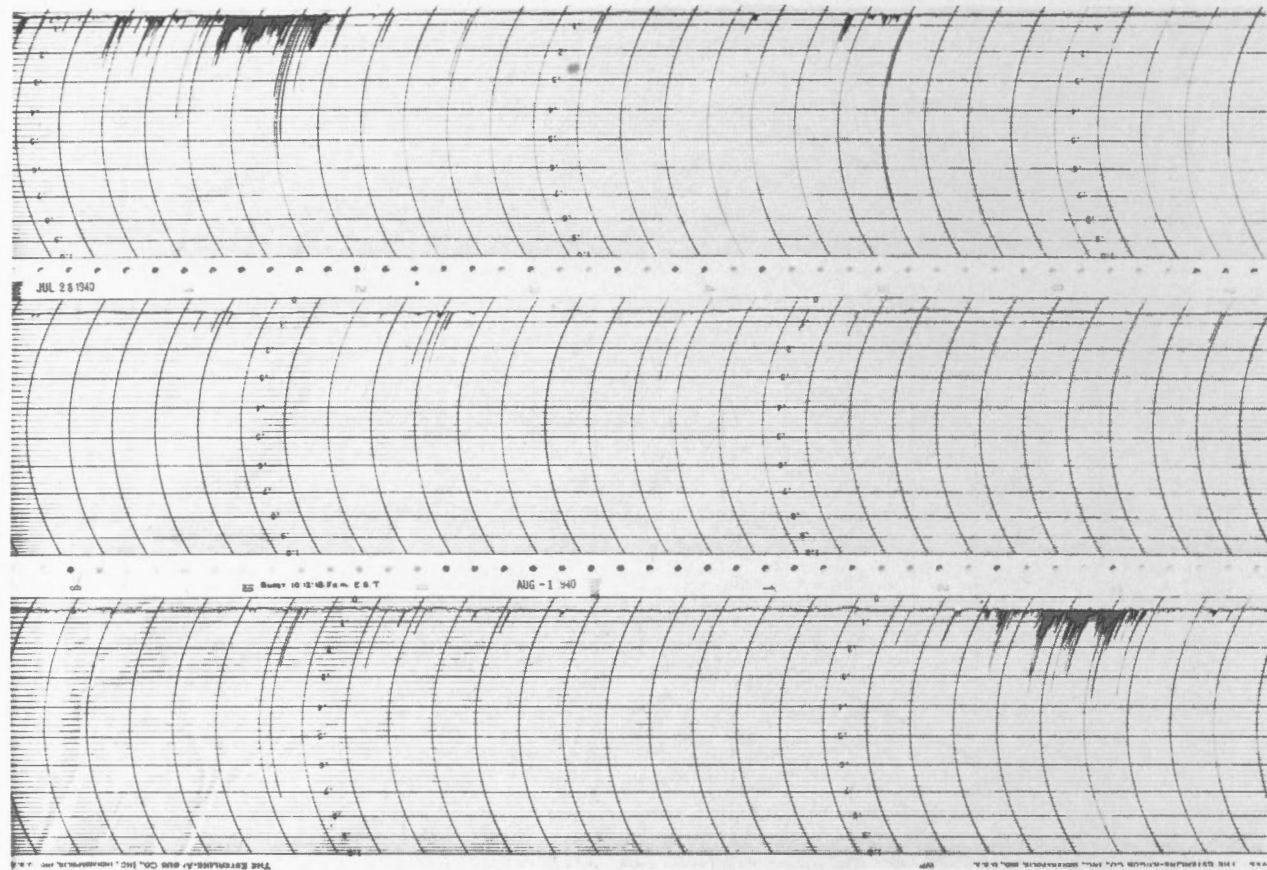

Fig. 26 Record on Esterline-Angus Recorder: Mine Seismograph.

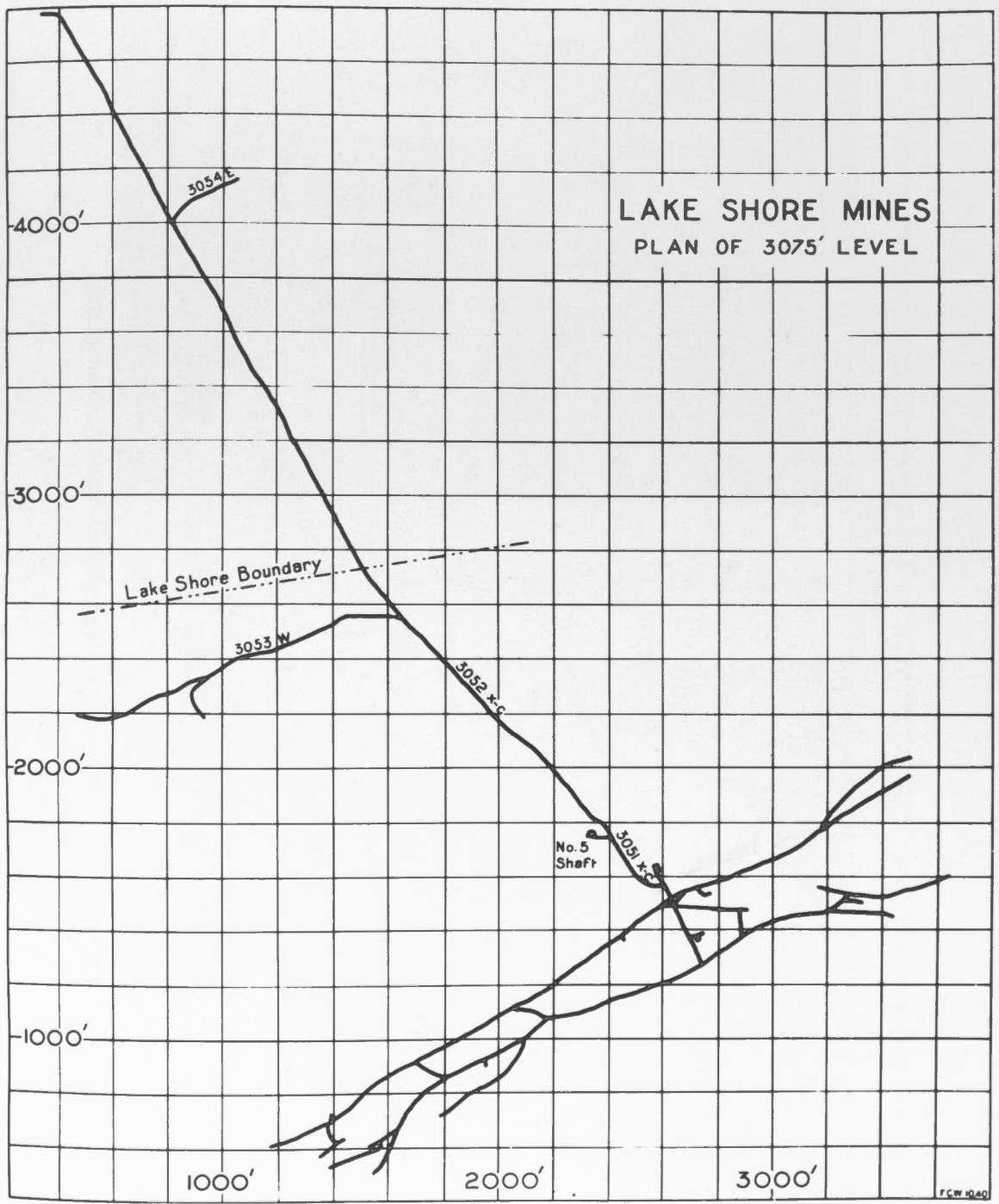

Fig. 27 Plan of 3075-ft. Level, Lake Shore Mines.

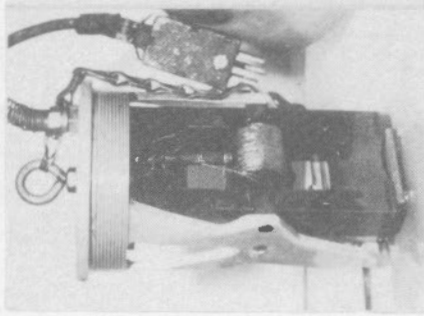
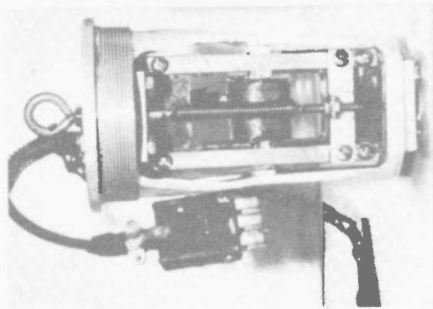
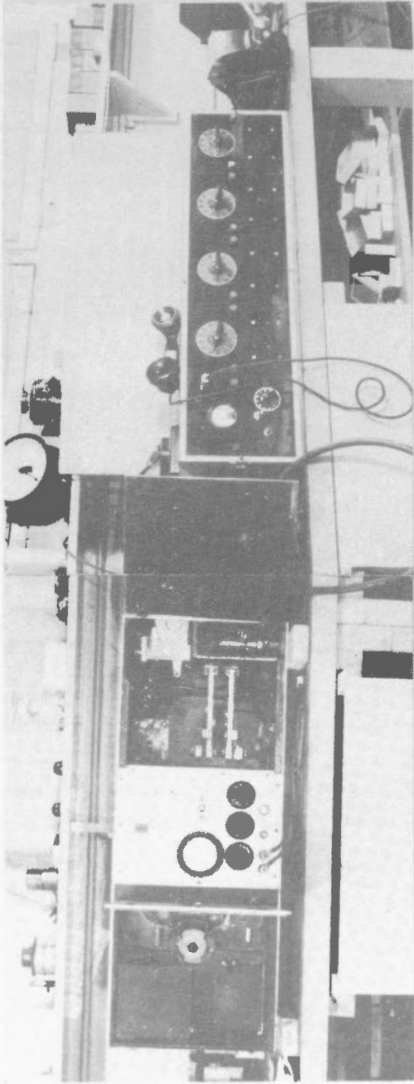

Fig. 28 High-speed Seismograph Equipment Leased from Leet.

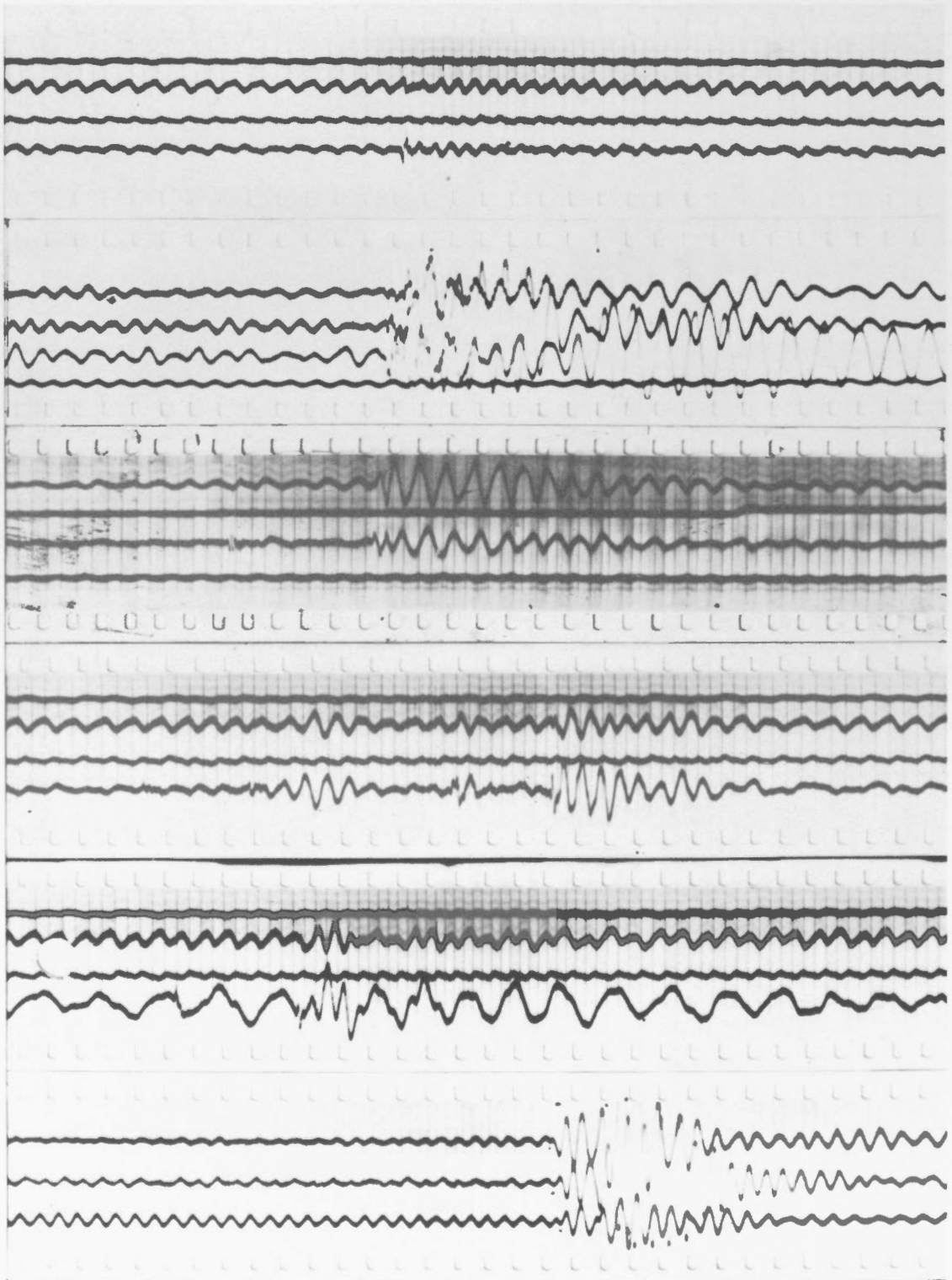

Fig. 29 Records (a) to (f): Leet Equipment (underground)

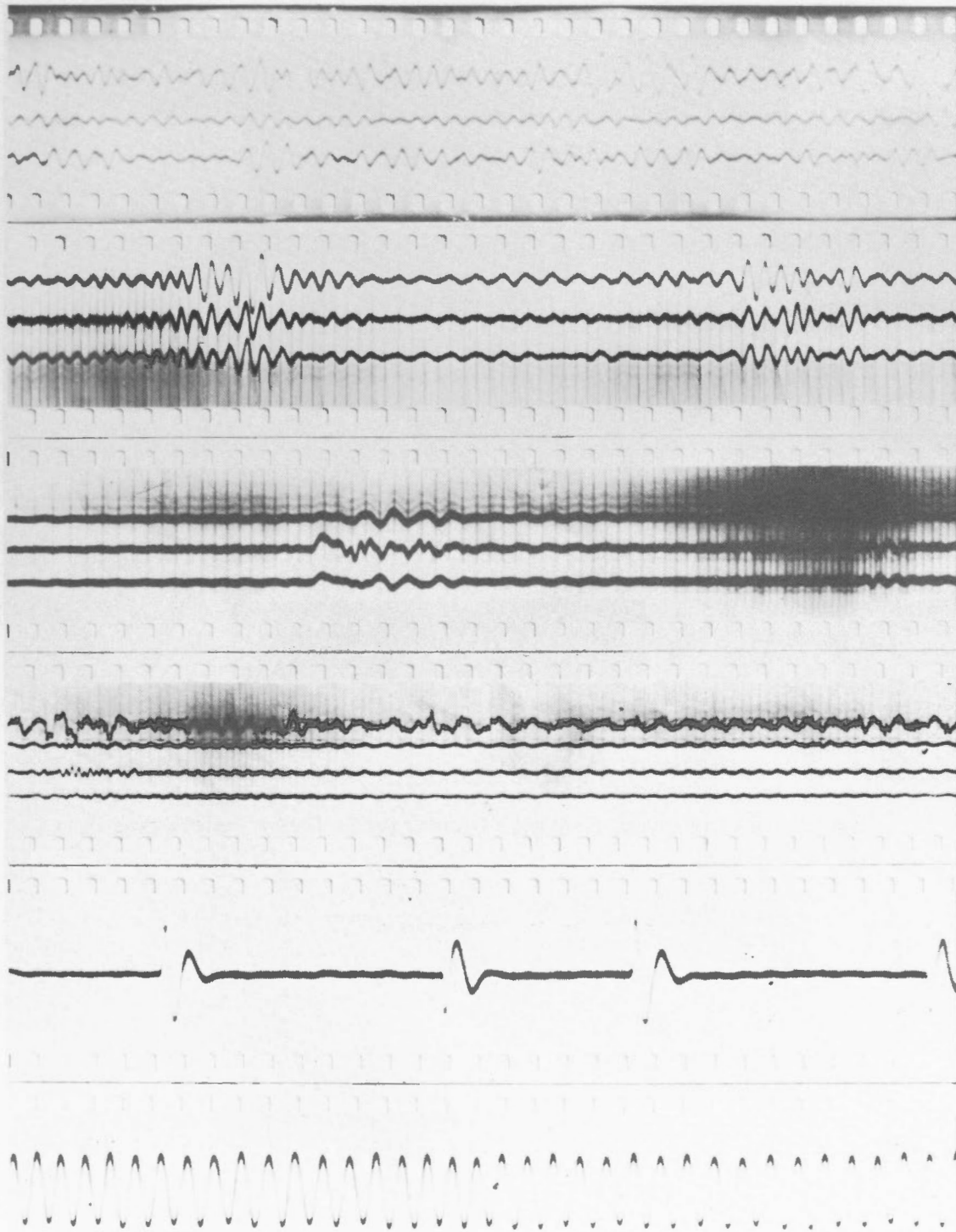

Fig. 30 Records (a) to (f): Leet Equipment (check records).

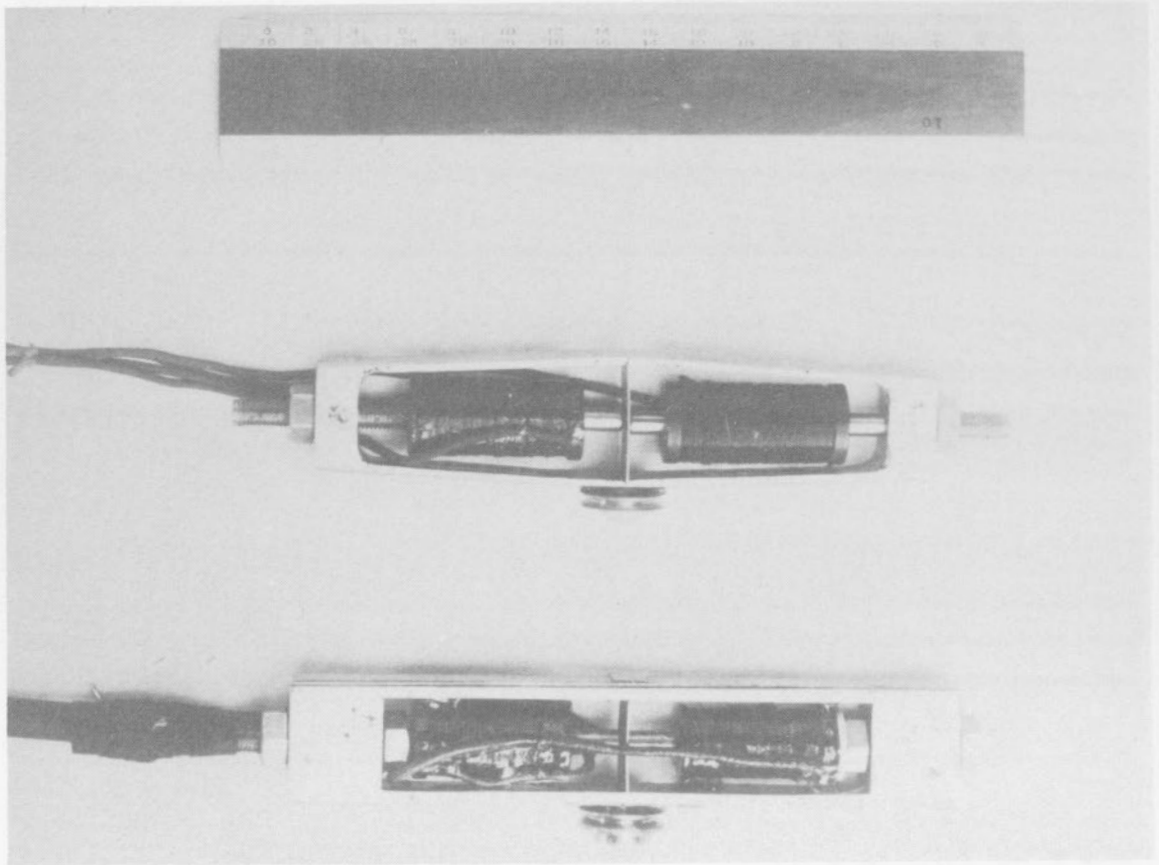

Fig. 31 Hollinsworth Borehole Convergence Gauge (microgauge).

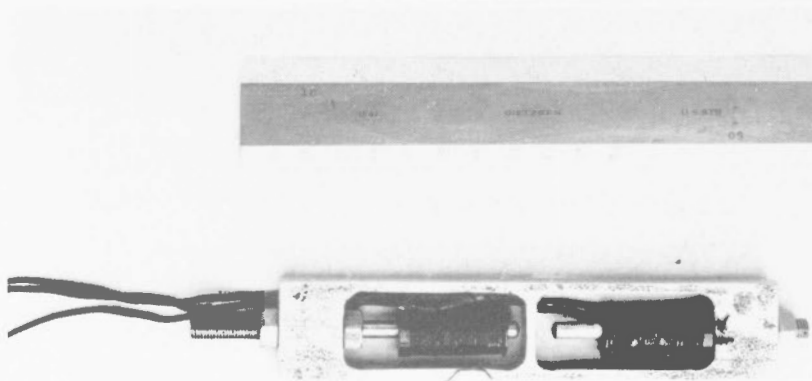
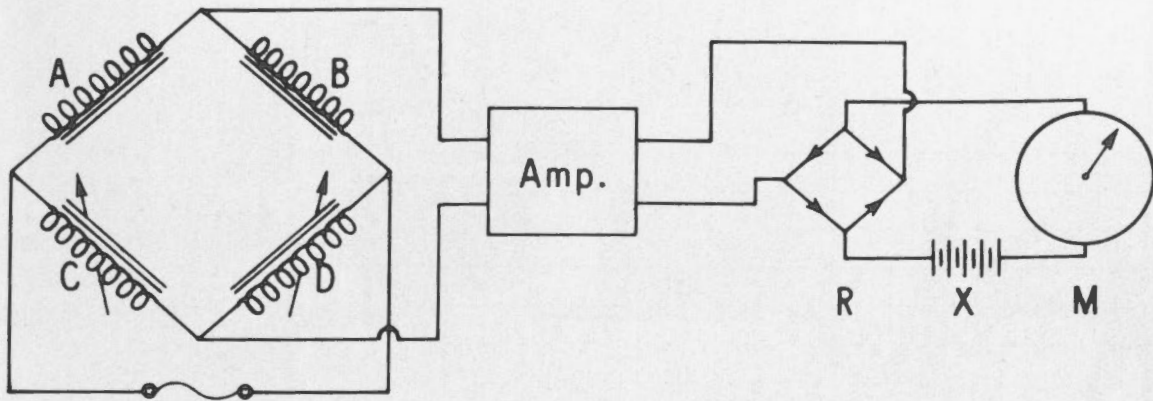

Fig. 32 Hollinsworth Calibrating Gauge.



Wiring Diagram of Microgauge

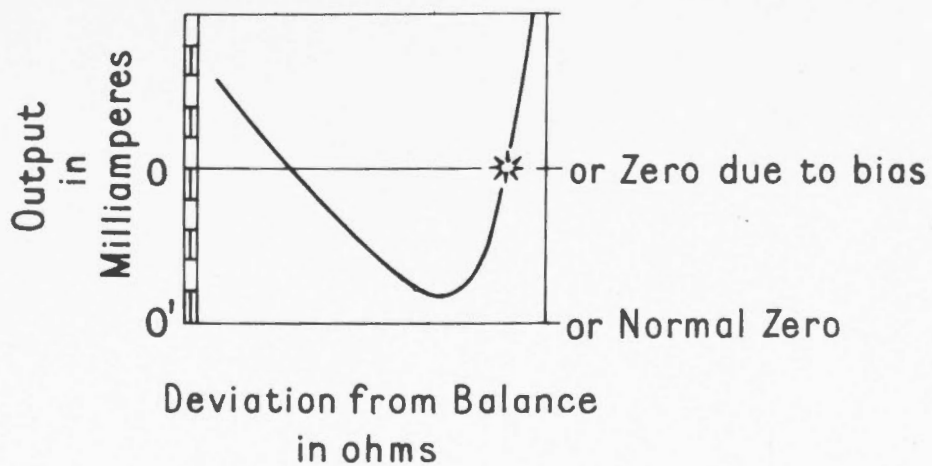

Fig. 33 Hollinsworth Microgauge Wiring Diagram.

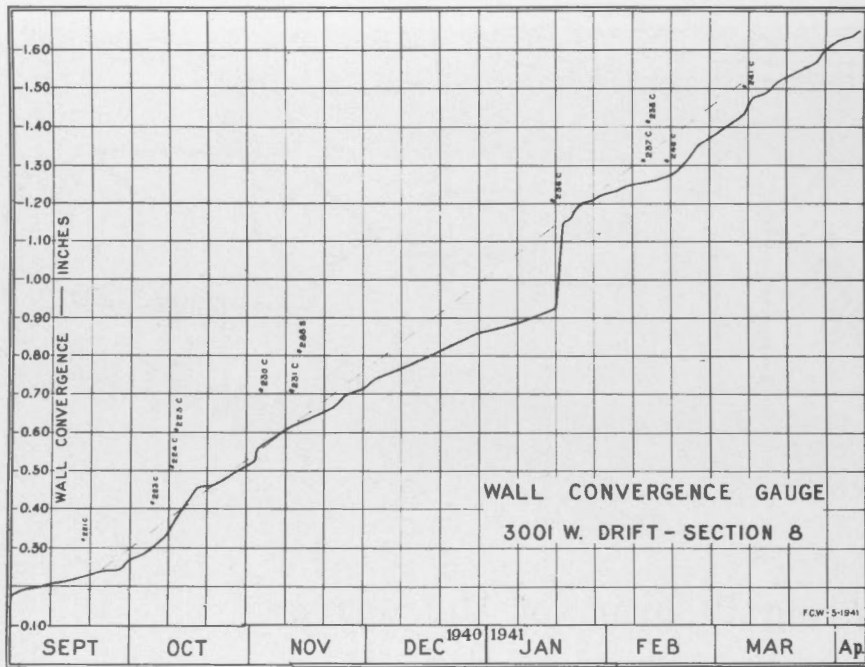

Fig. 34 Record Hydraulic Convergence Gauge.

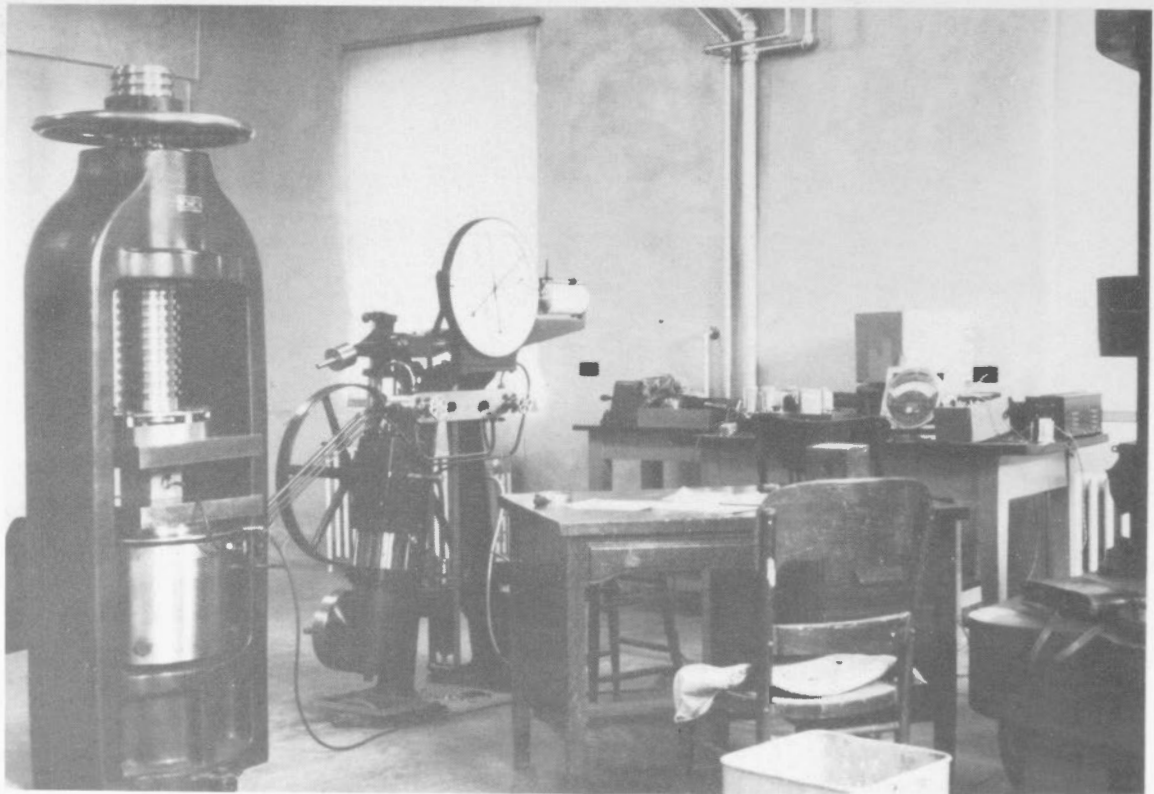

Fig. 35 Hydraulic Press Tests of Hollinsworth Gauge.

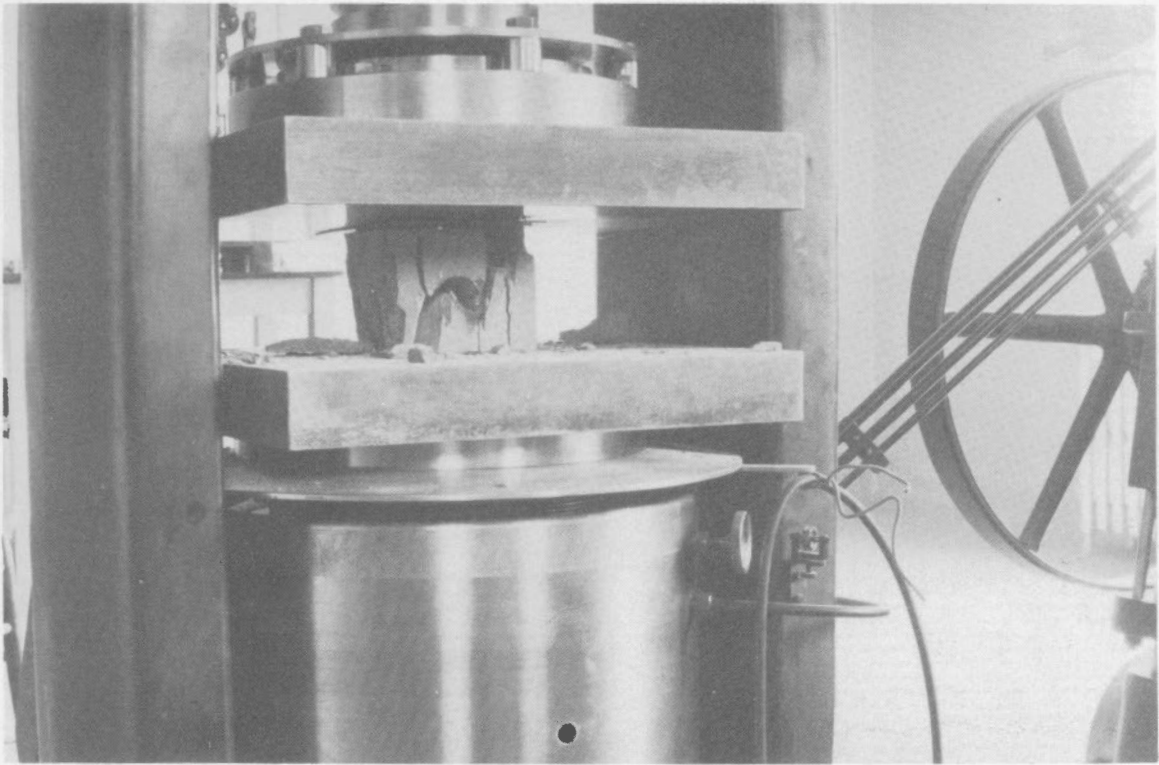

Fig. 36 Rock Crushing Experiments with Hollinsworth Gauge.

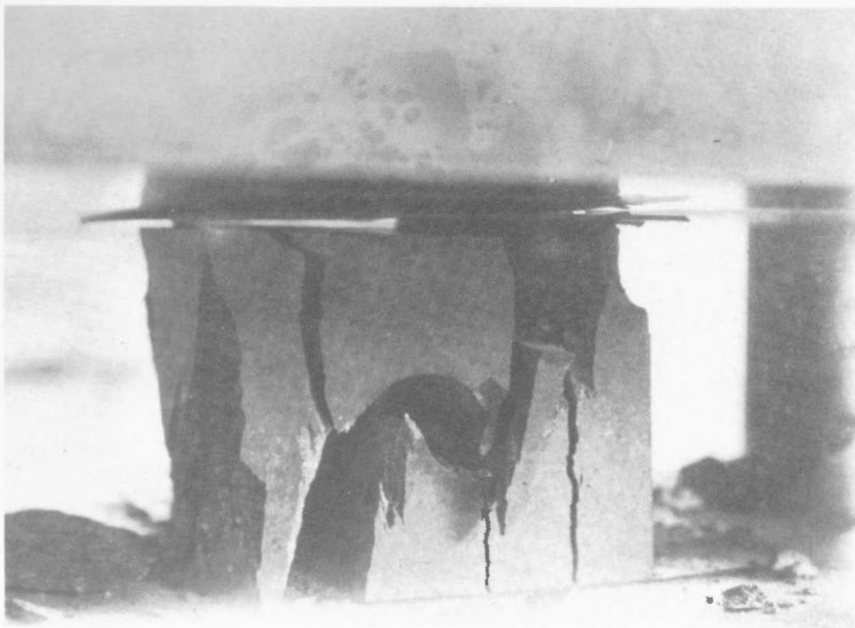

Fig. 37 Small Syenite Block after Crushing.

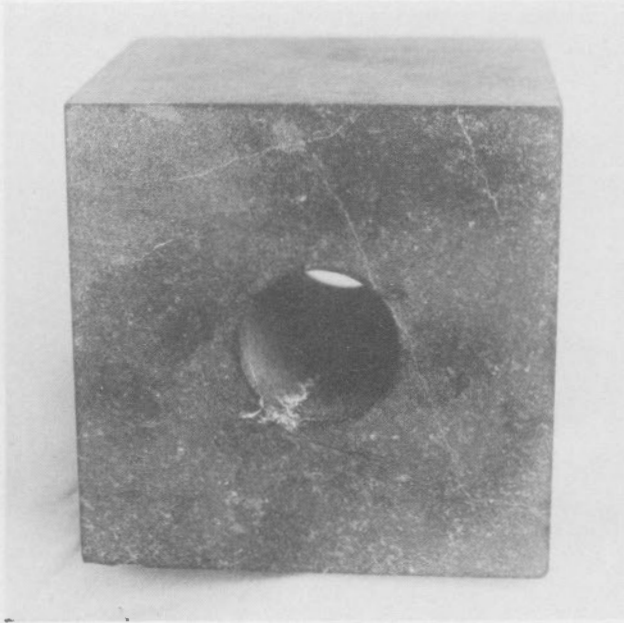
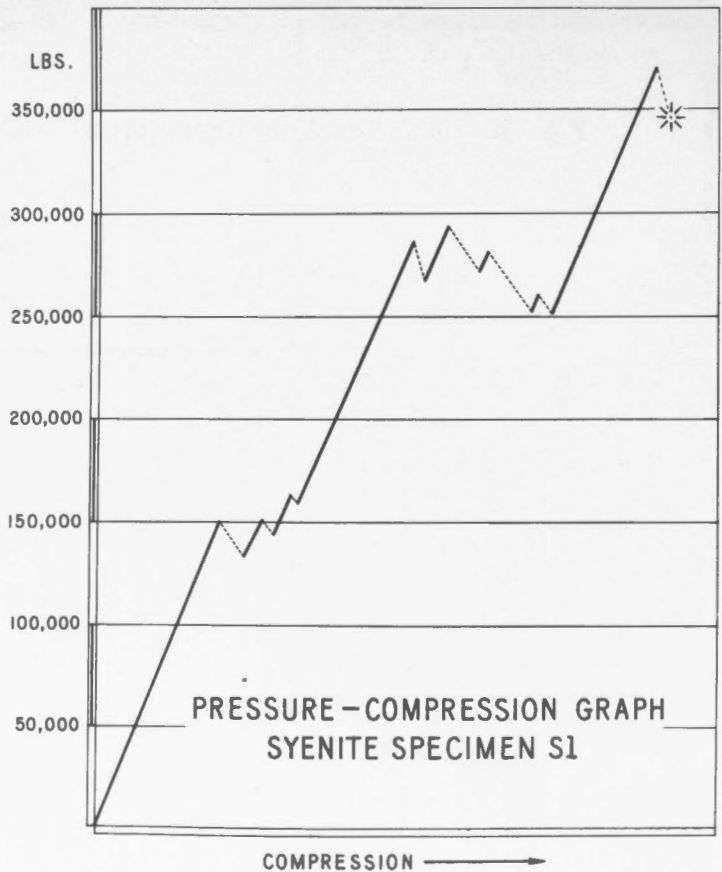

Fig. 38 Porphyry Specimen P after Pressure to 9,150 lbs/sq. in.

Fig. 39 Pressure Compression Graph - Syenite Specimen S₁.



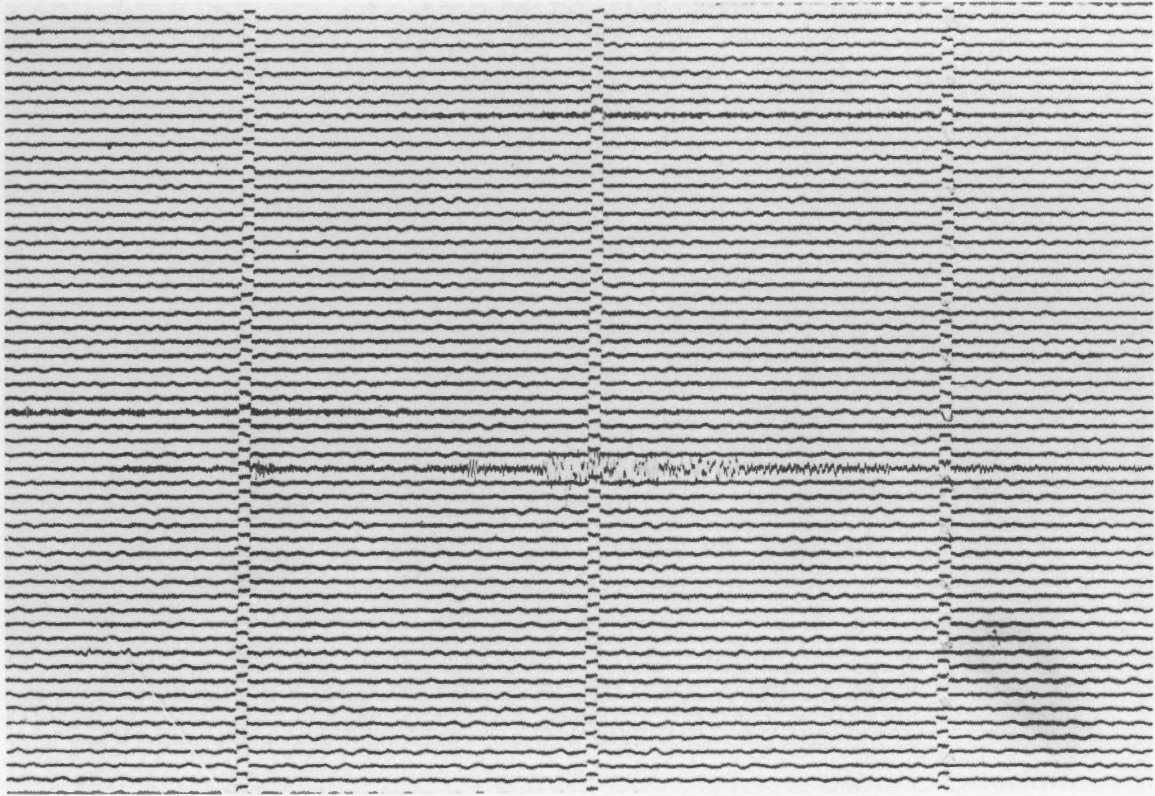

Fig. 40 Typical Ottawa Record of Kirkland Lake Rockburst.

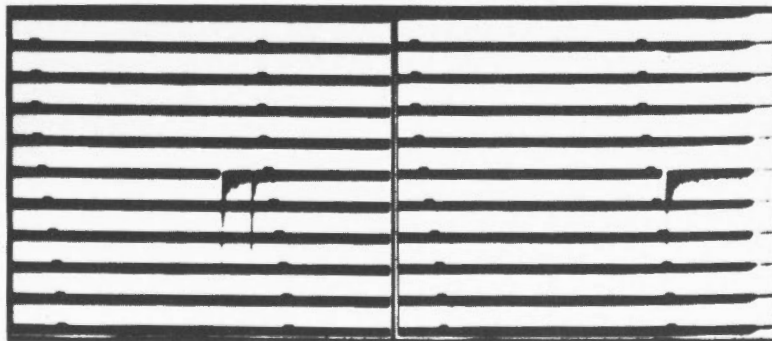

Fig. 41 Bursts I, I_a and J as Recorded on the Lake Shore Surface Seismograph, July 30, 1941.

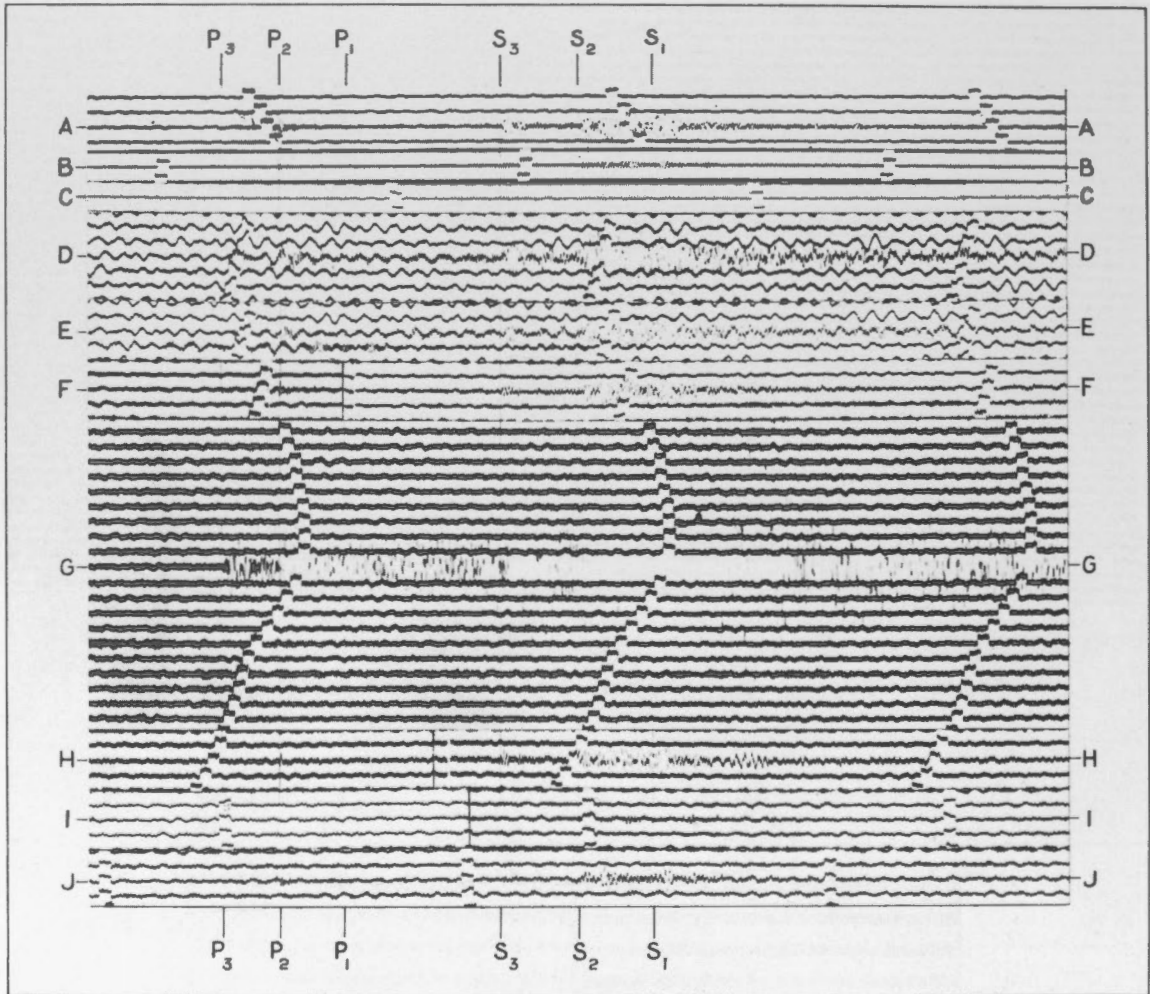

Fig. 42 Comparison of Records from the Benioff Seismograph at Ottawa

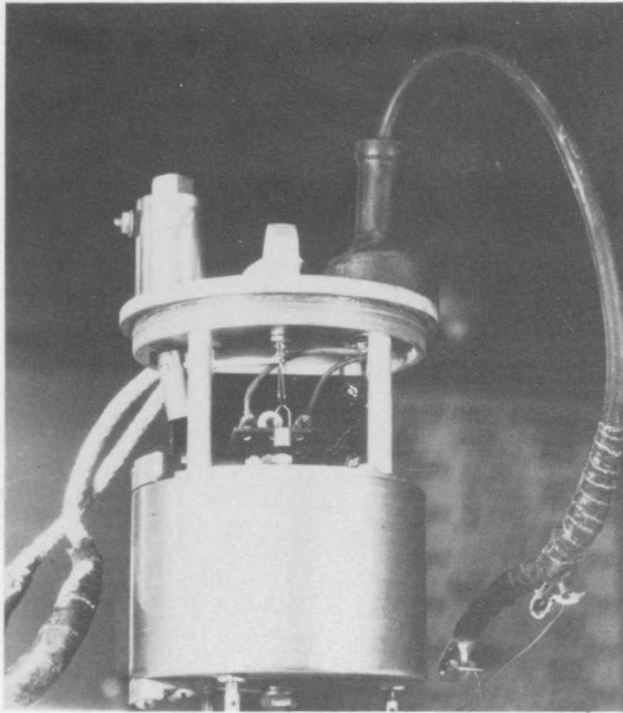

Fig. 43. Heiland Geophone with Sensitivity Tester.

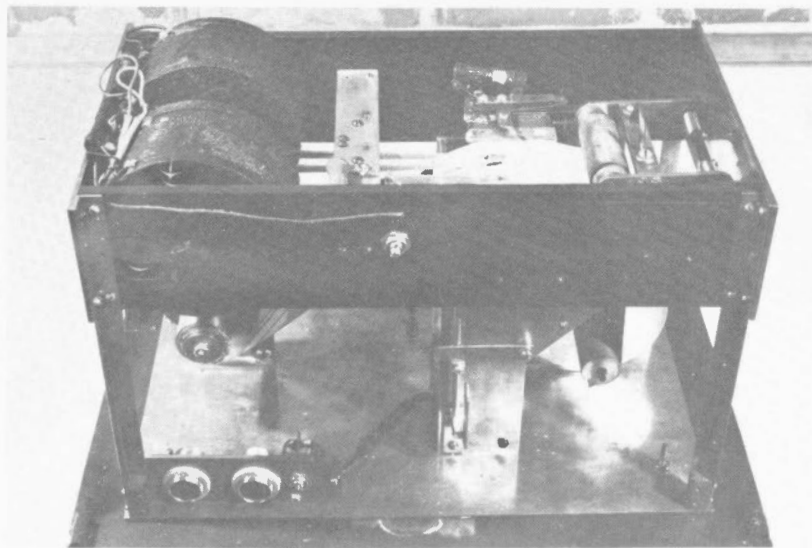

Fig. 44 Side View
Obert
Recorder

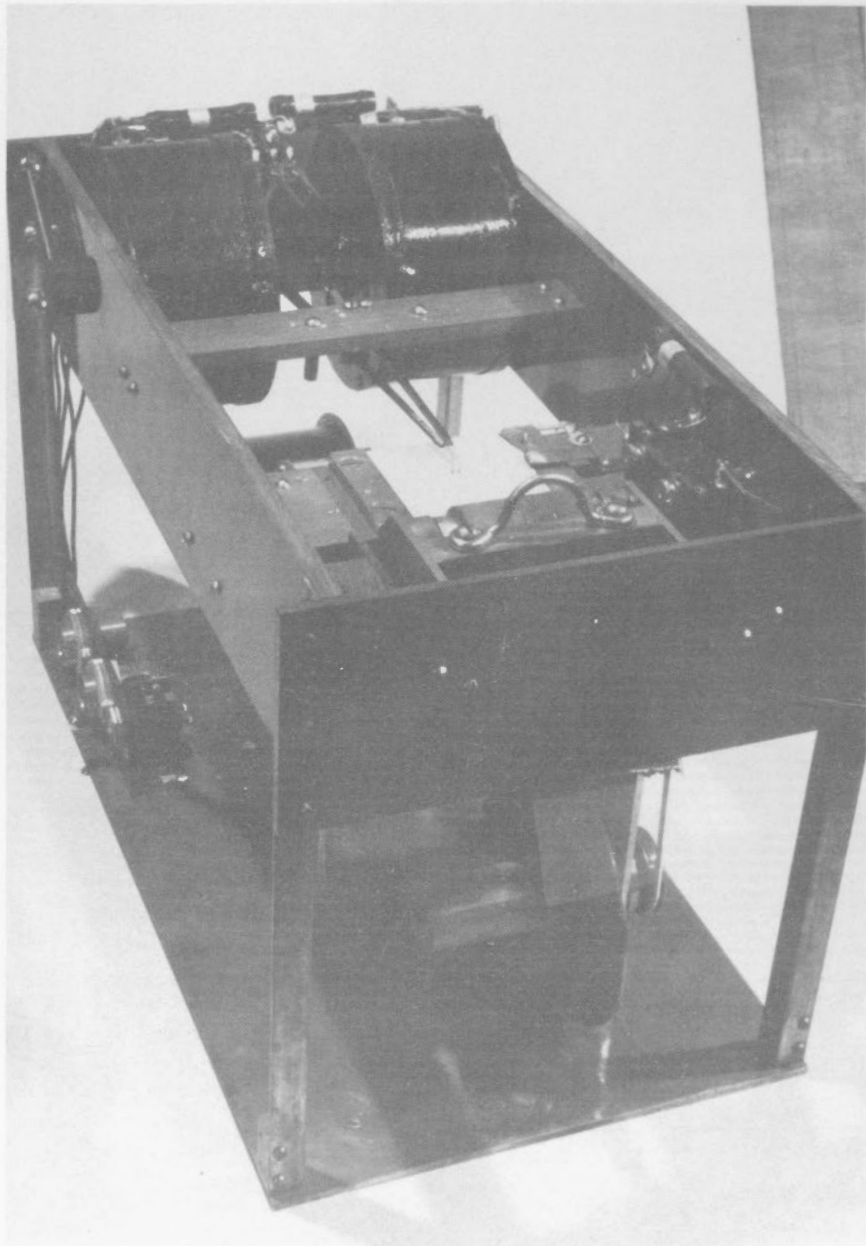

Fig. 45 End View: Obert Recorder.

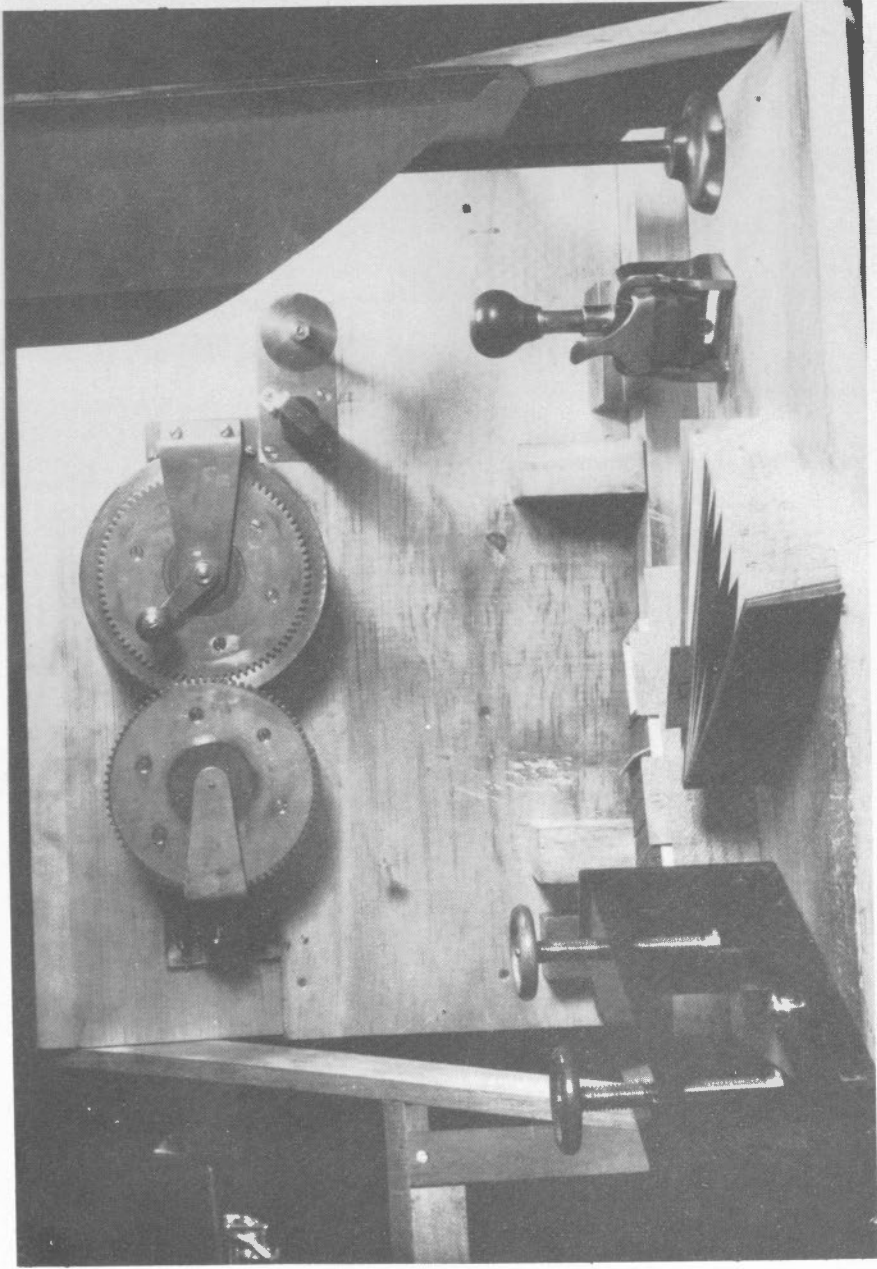

Fig. 46 Record Pleater and Accessories.

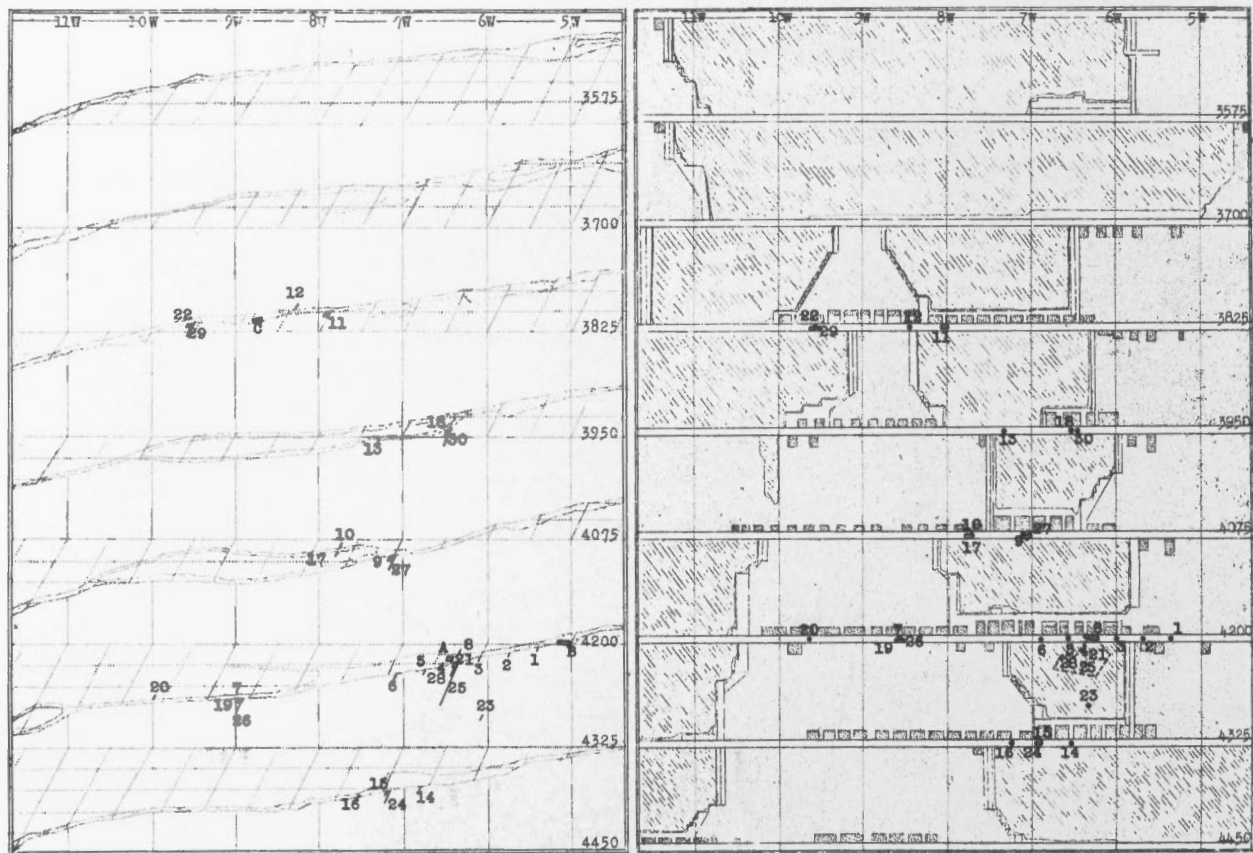

Fig. 47 Location of Test Holes Nos. 1-30.

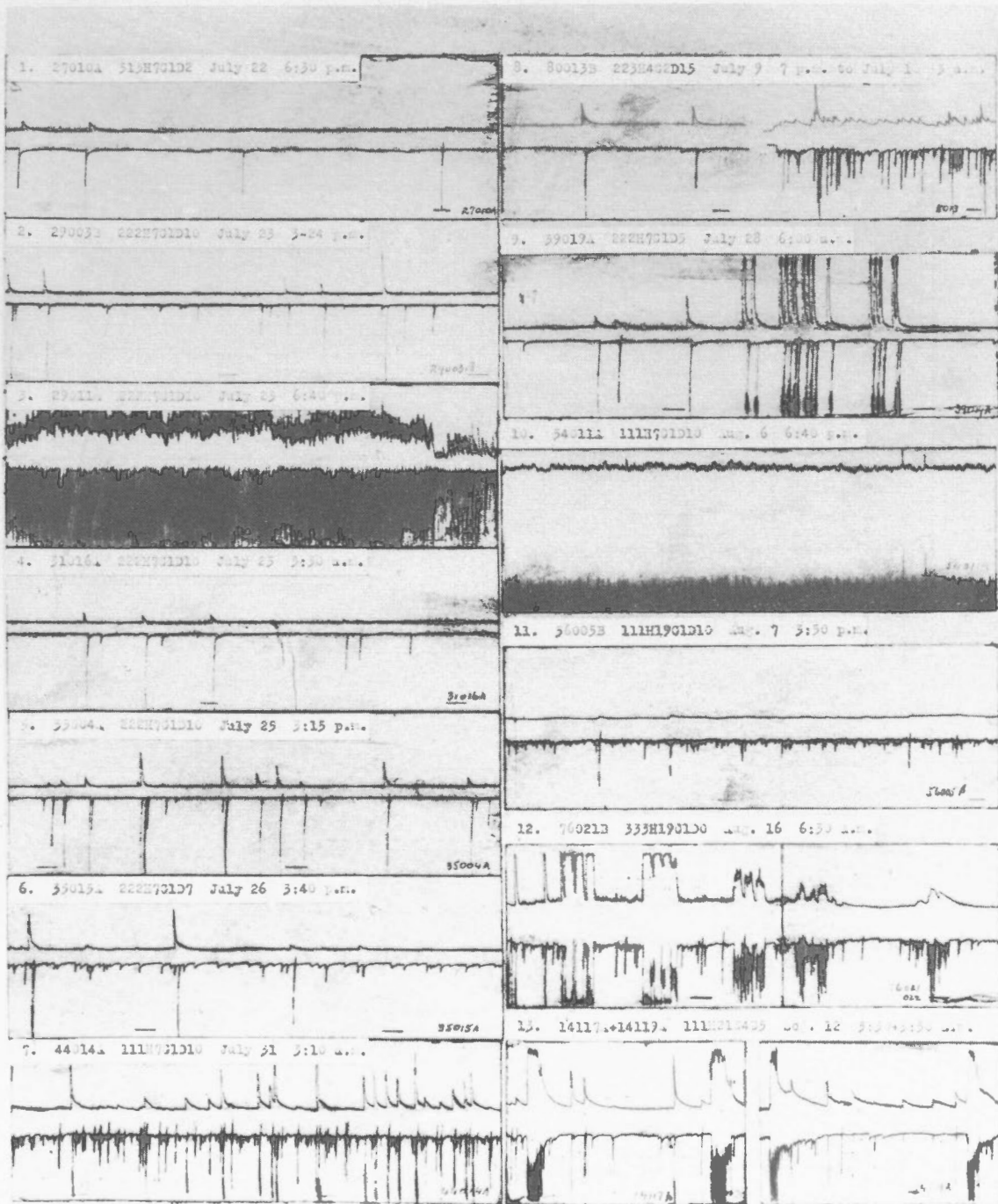

Fig. 48 Record of Activity in 4201W10 in Relation to the Rockburst of July 25 (together with some typical interference records).

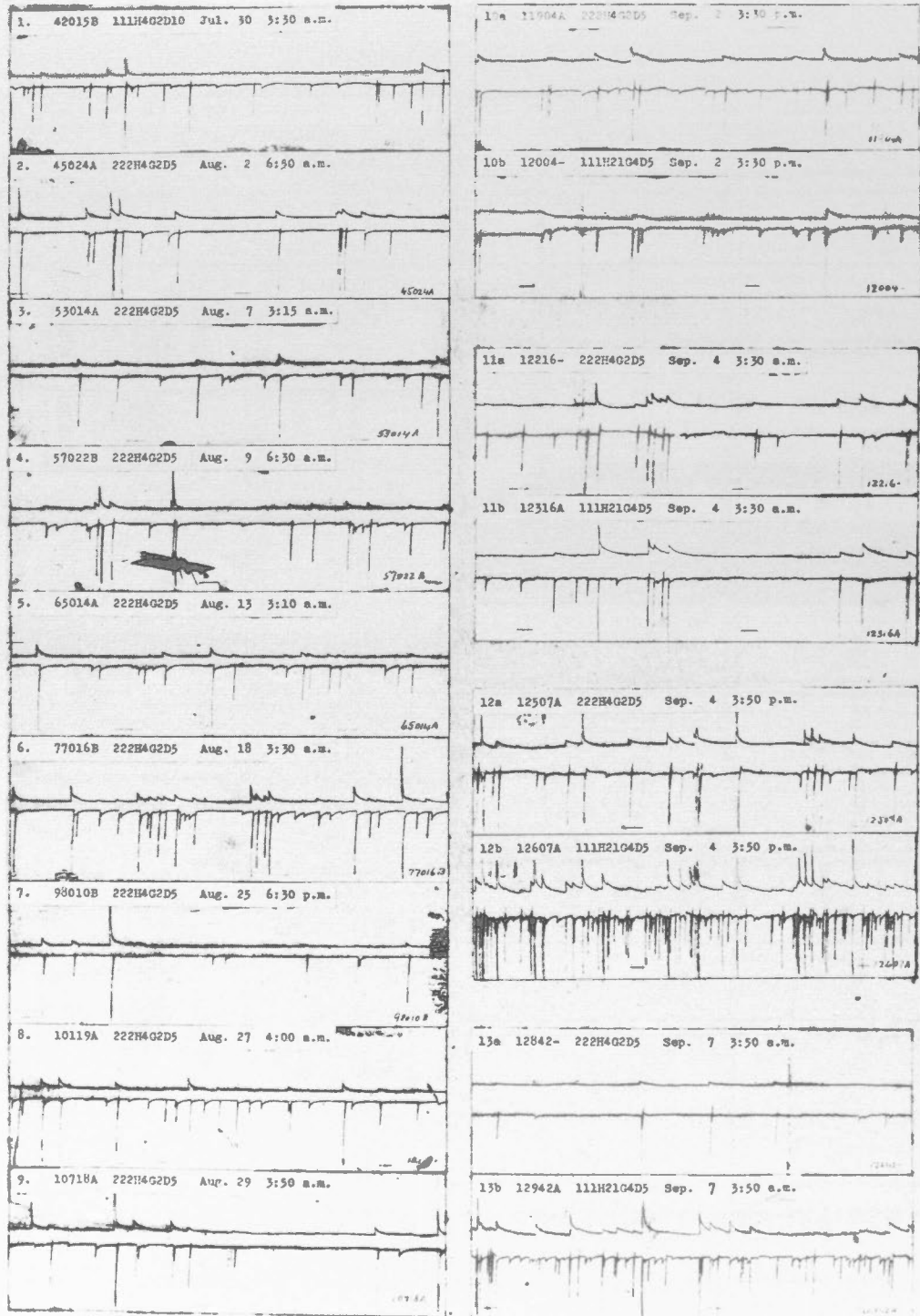

Fig. 49 Record of Activity in 4201W8 (up to and after bringing through a raise from 4300-ft. level on Sept. 5).

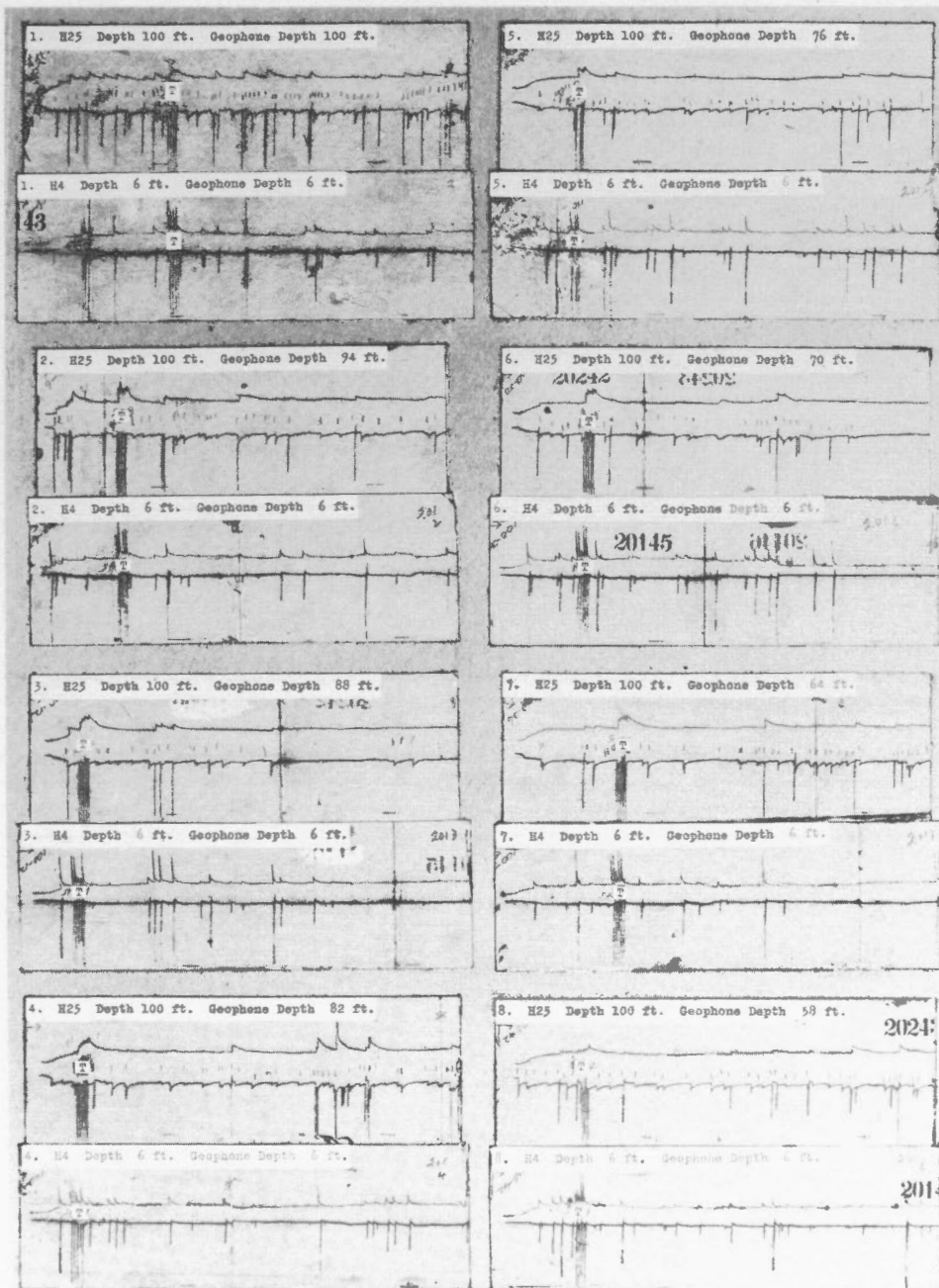

Fig. 50 Comparison of Recording in Adjacent Deep and Shallow Holes (deeper records).

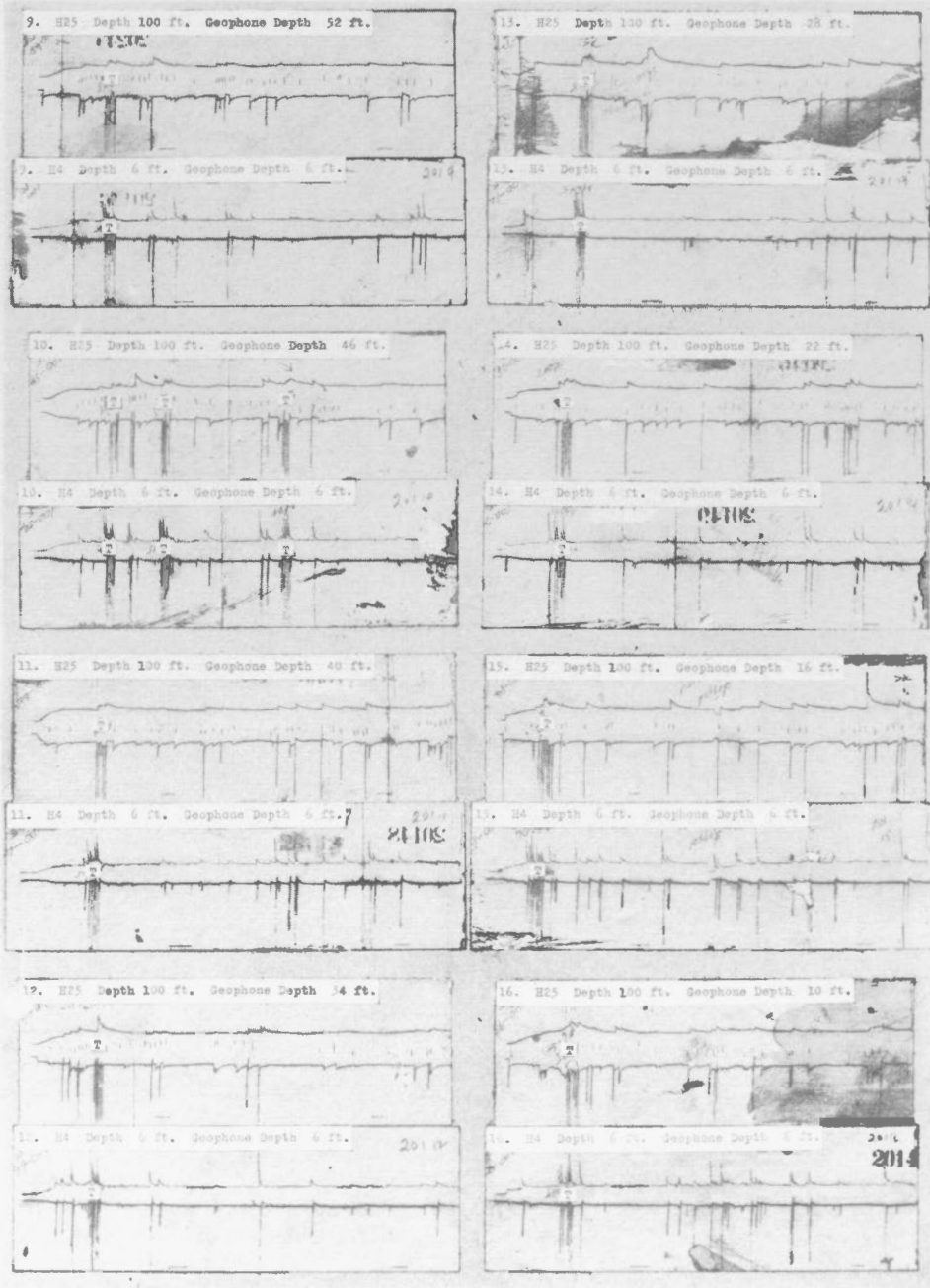

Fig. 51 Comparison of Recording in Adjacent Deep and Shallow Holes (shallower records).

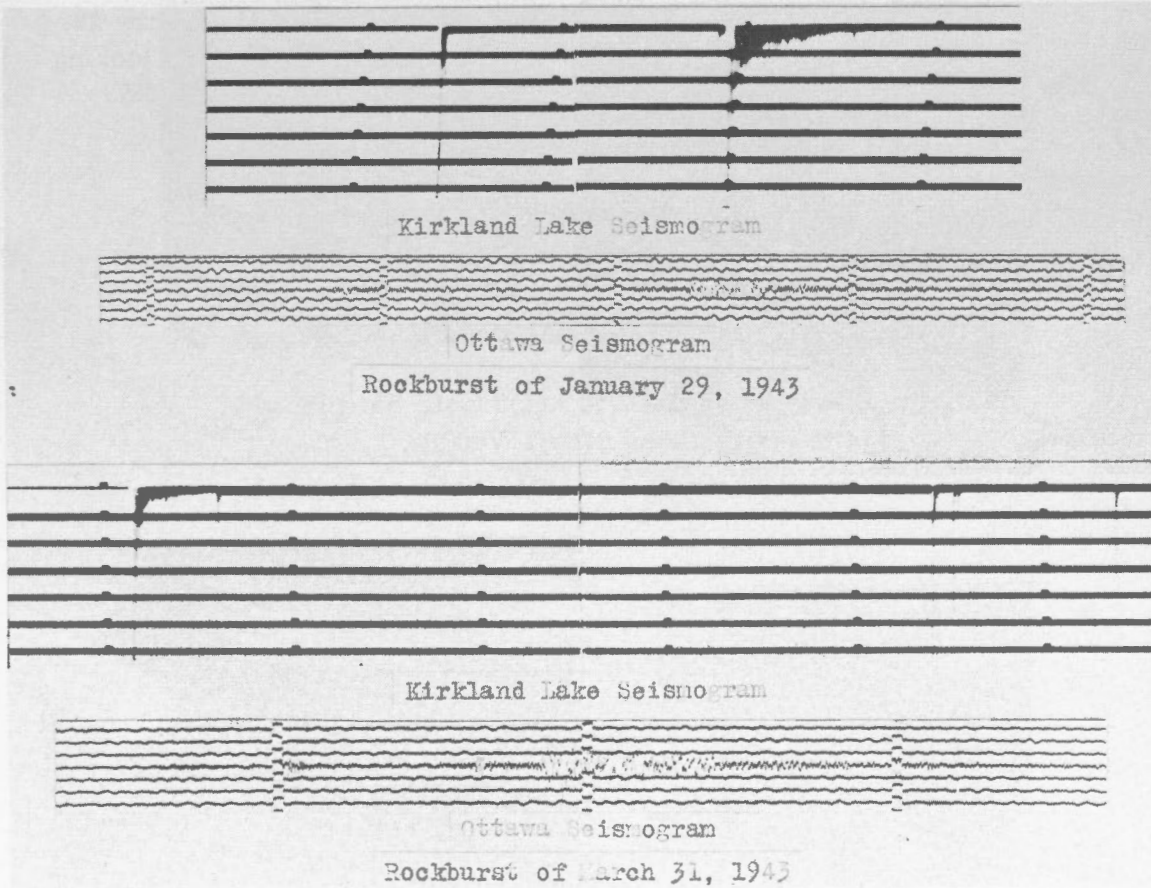

Fig. 52 Kirkland Lake and Ottawa Seismograms of the Rockburst of January 29, 1943.

Fig. 53 Kirkland Lake and Ottawa Seismograms of the Rockburst of March 31, 1943.



Fig. 54 Rockburst of January 29, 1943; 3801W Drift looking west from Sec. 6.5W.

Fig. 55 Rockburst of January 29, 1943; 3901W Drift, looking west from Sec. 6.5W.





Fig. 56 Rockburst of January 29, 1943;
3908W Drift, looking west from
Sec. 7W.



Fig. 57 Rockburst of January 29, 1943;
4001W Drift, looking west from
Sec. 6.7W.

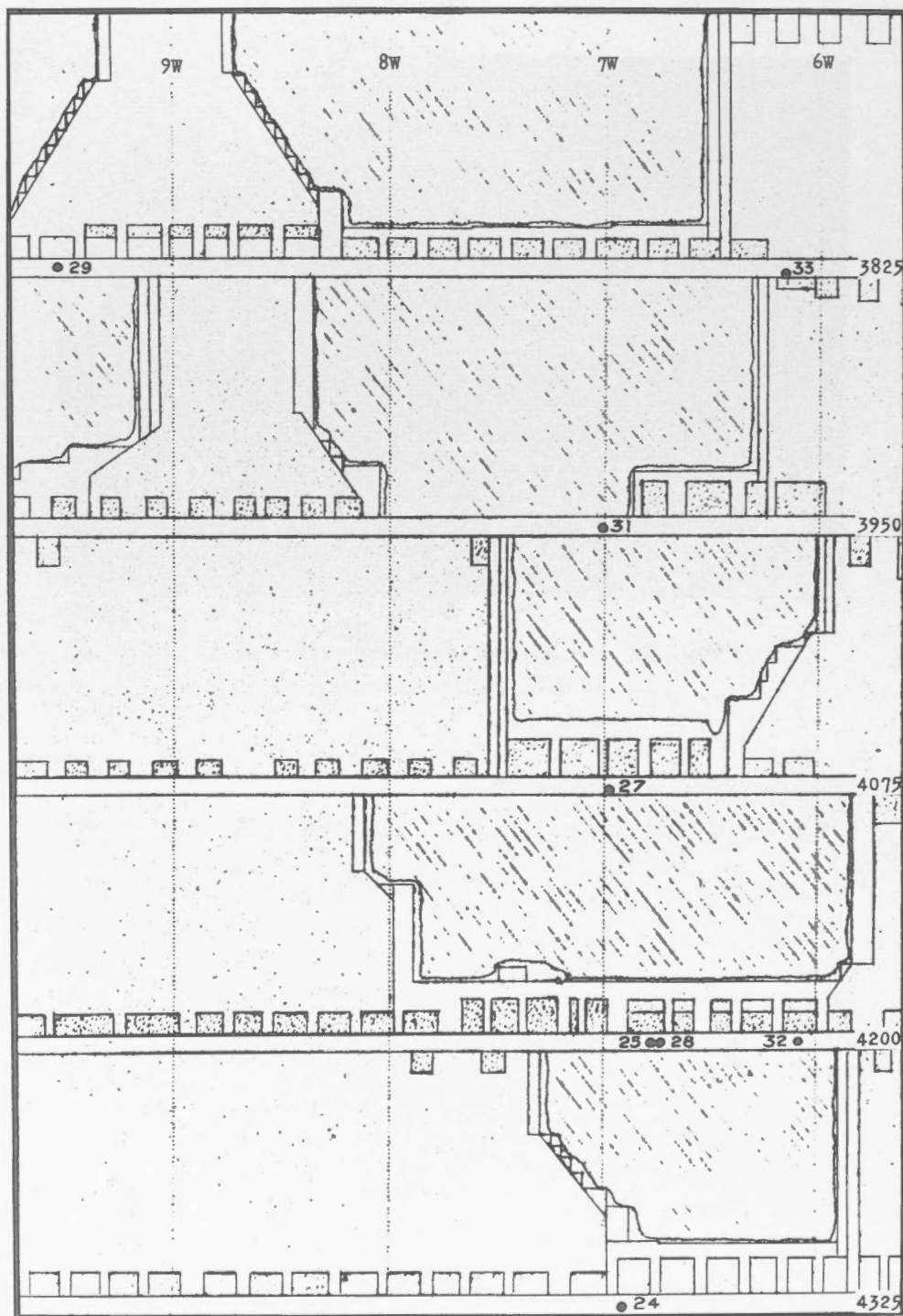

Fig. 58 Sections of West Pillar Affected by Rockburst of January 29, 1943.

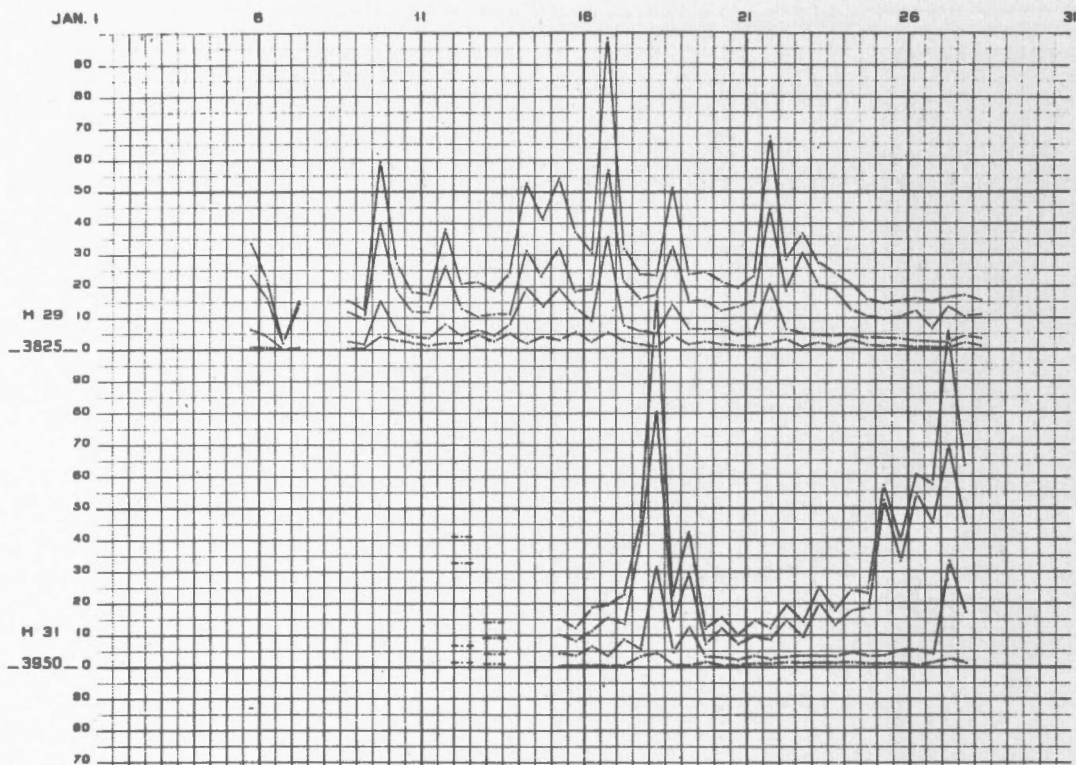

Fig. 59 Record Counts: Holes 29 and 31; January 6-28, 1943.

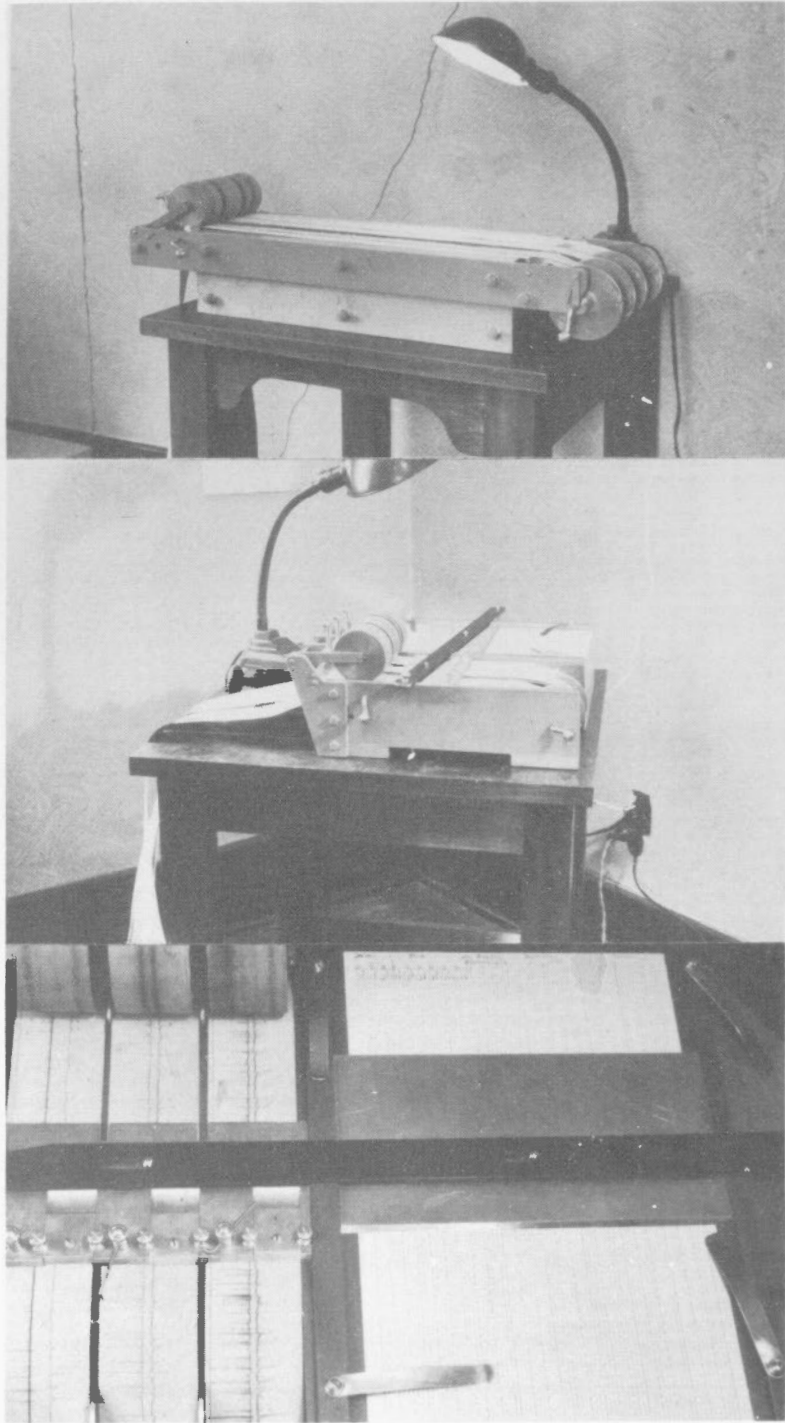

Fig. 60 Annotator and Comparator.



Fig. 61 Pressure Shift, January 16-18, 1943.

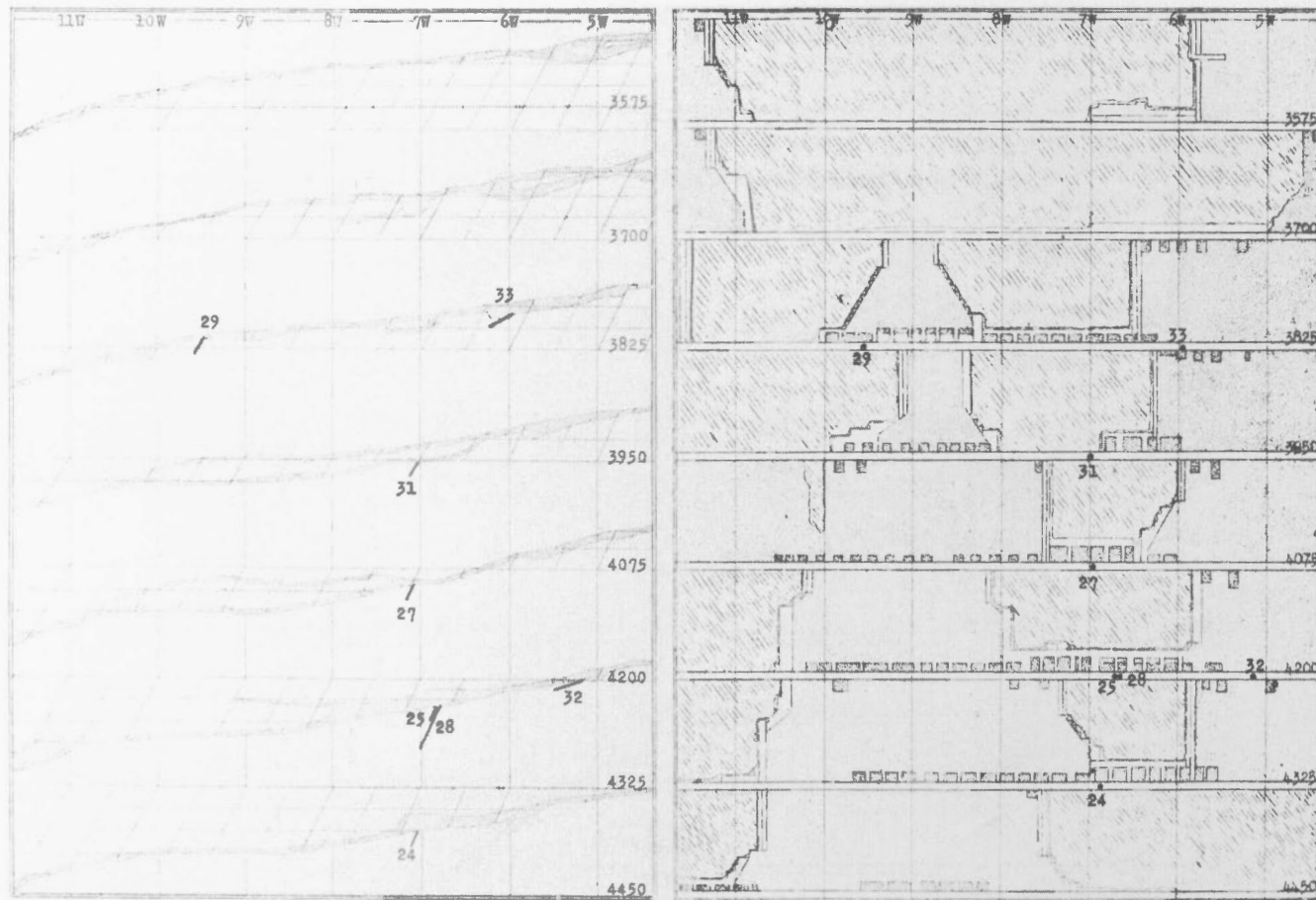

Fig. 62 West Pillar Showing Geophone Placements.



Fig. 63 Test Hammer;
4700-ft. Level.

Fig. 64 Loading Geophone
into Borehole.



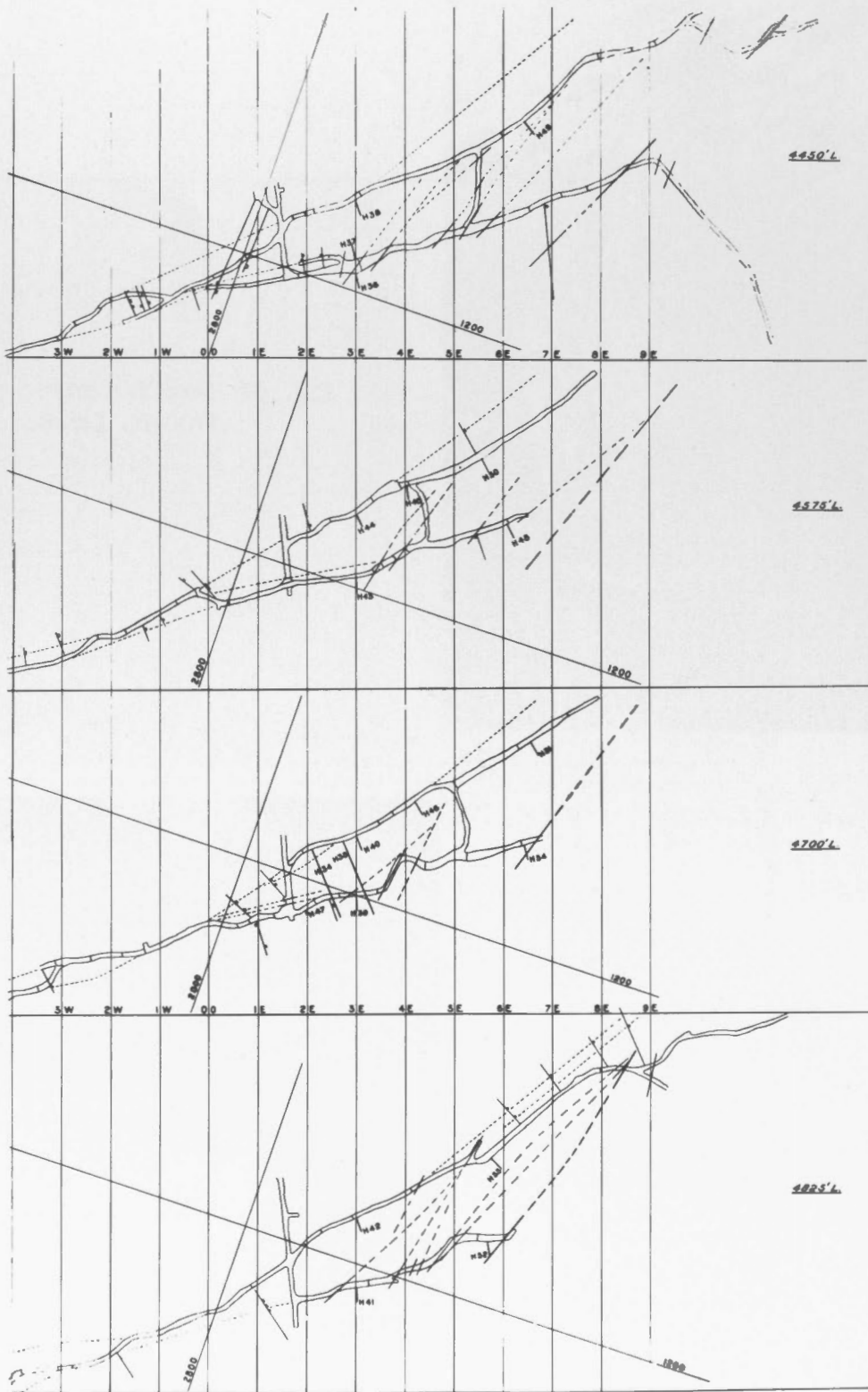

Fig. 65 Location of Test Holes Nos. 31-54.

From: 16h 01 m to 16h 31 m. Date: Feb. 11th 1944. Read by: *C*

| Rec. 175 | Rec. 176 | Rec. 177 | 2393 | | | | |
|-----------------|-------------------|------------------|------------------|------|------------------|---|----------------|
| 1B | 1A | 5B | 5A | 4B | 4A | | |
| N.43 | N.44 | N.47 | N.40 | N.41 | N.42 | | |
| 19 | | | | | | | |
| A. | | | | | | | |
| K | | | | | | | |
| 20 6 36 5 | 51 18 17 6 20 3 | | | | | | |
| 21 | | | | | | | |
| T | | | | | | | |
| 18 4 28 5 | 63 14 12 3 20 3 | | | | | | |
| 23 | | | | | | | |
| 25 | | | | | | | |
| 17 6 32 6 | 47 13 16 6 23 3 | | 43 19 - 26 19 12 | 6 | 9.17 2.67 6.50 | | |
| | | | 19 44 - 20 16 12 | 6 | 16.00 2.67 13.33 | | |
| | | | - - 47 - - - | 6 | - - - | | |
| | | | 26 20 - 40 20 12 | 6 | 26.83 7.50 19.33 | | |
| 55 16 96 16 - - | 161 45 45 15 63 9 | 19 16 - 20 41 12 | | | | 6 | 7.50 2.50 5.00 |
| 19 - 26 19 12 - | 20 16 12 - - - | 20 12 12 | 12 12 - 12 12 42 | 6 | 10.50 1.50 9.00 | | |

Fig. 66 Typical Record Analysis Showing Coincidences.

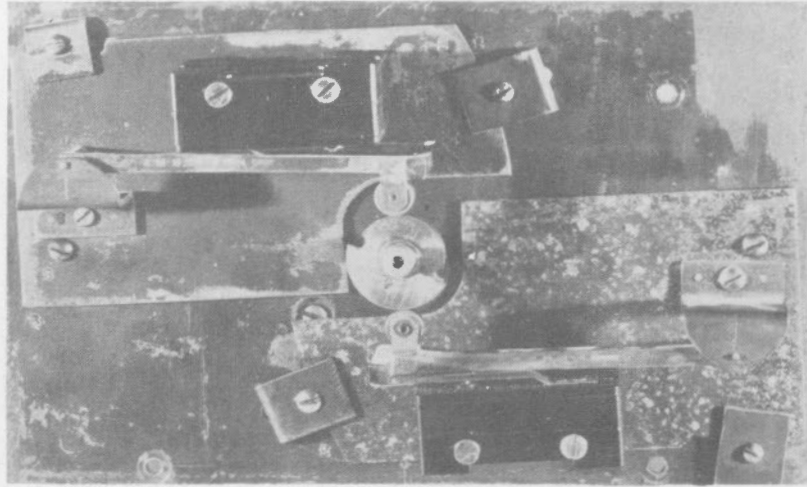

Fig. 67 Alternating Switch; Quadruple-line Recording.

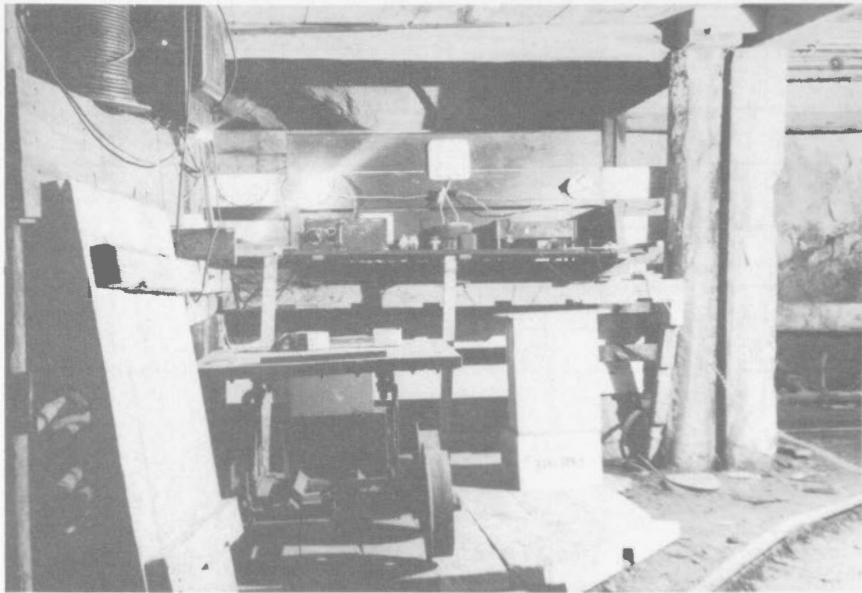

Fig. 68 Listening Post; 4700-ft. Level.

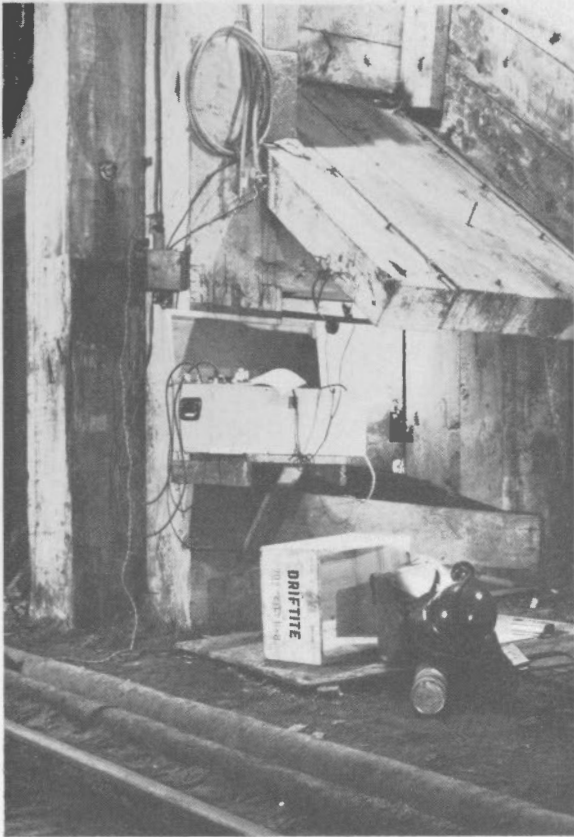

Fig. 69 Listening Post;
4400-ft. Level.

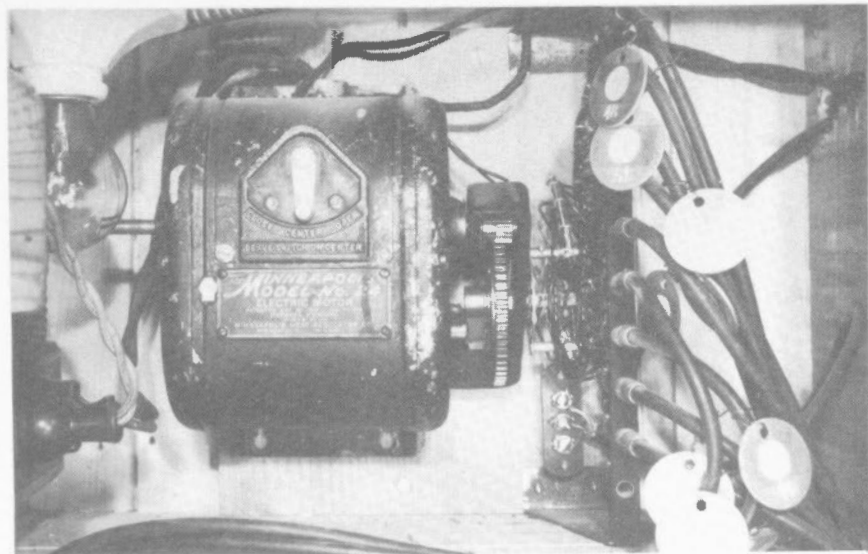

Fig. 70 Motor
Stepping
Switch

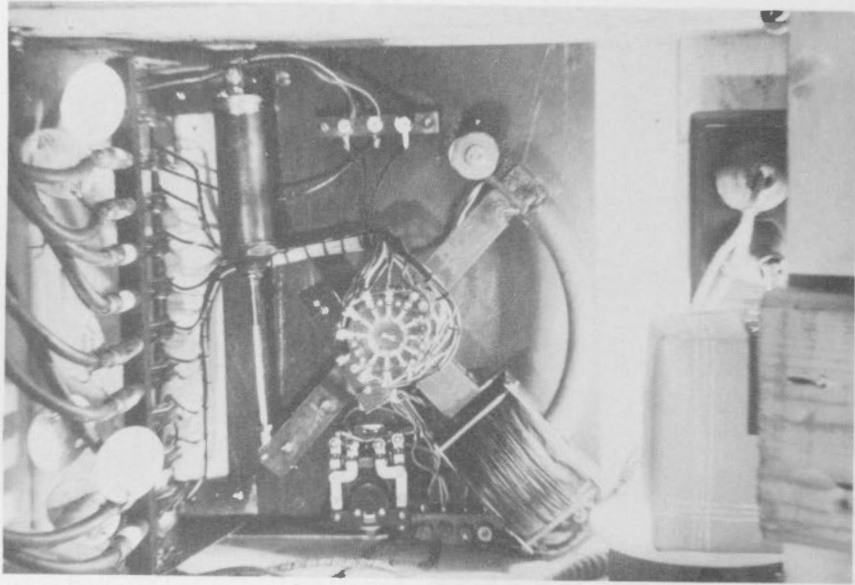

Fig. 71 Magnetic Stepping Switch.

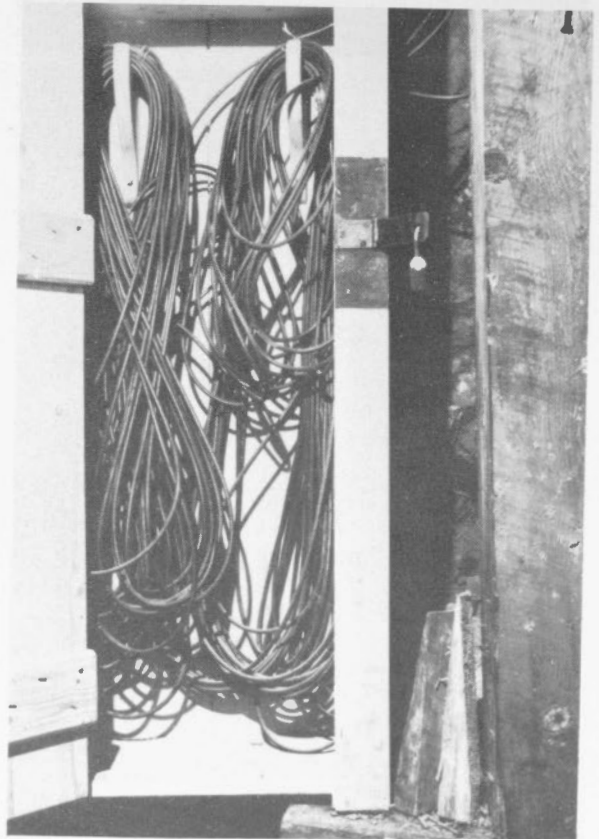
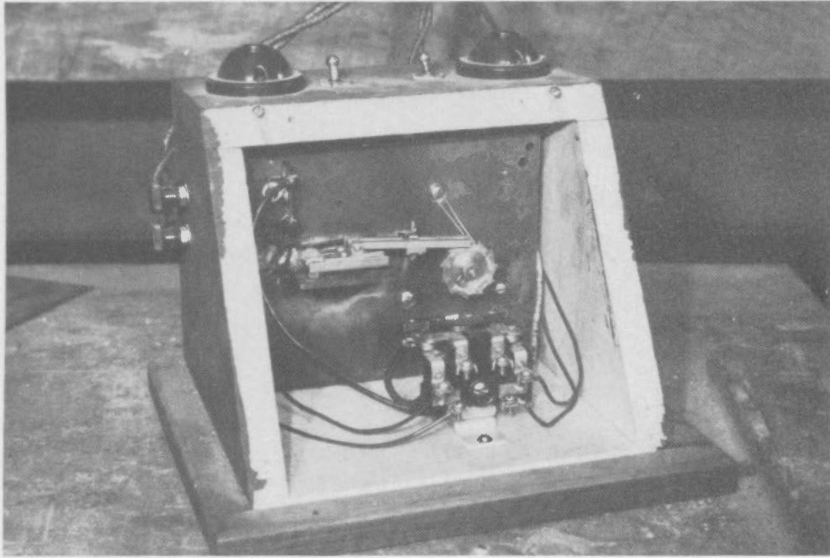

Fig. 72 Cable Reservoir;
4700-ft Level.



**Fig. 73 Program
Switch:
Intensive
Seismic
Program.**

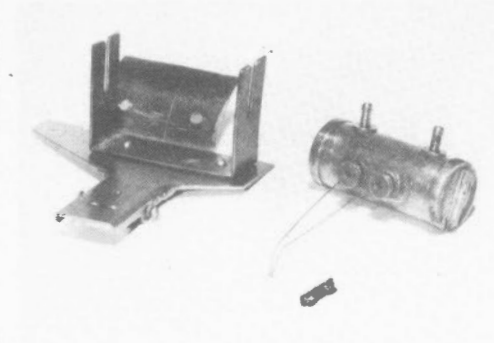
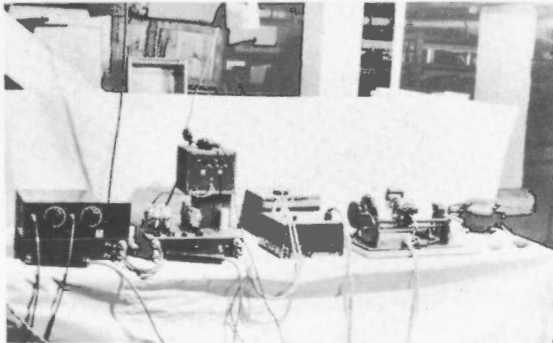
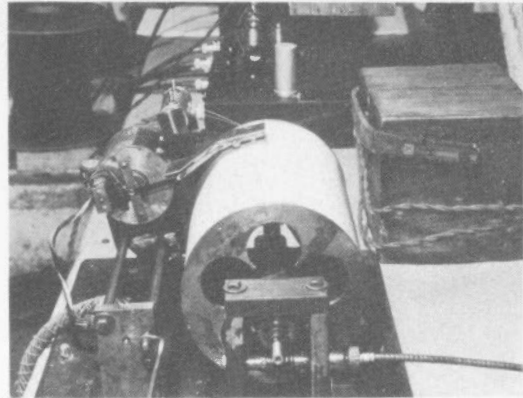
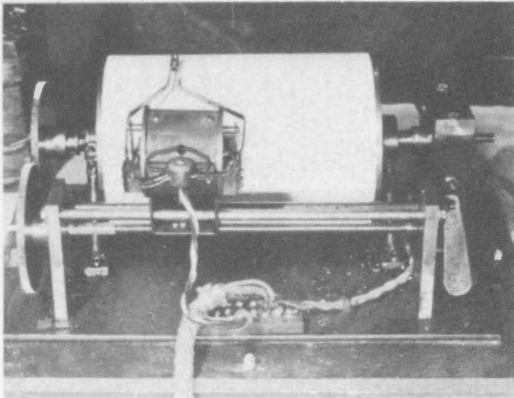
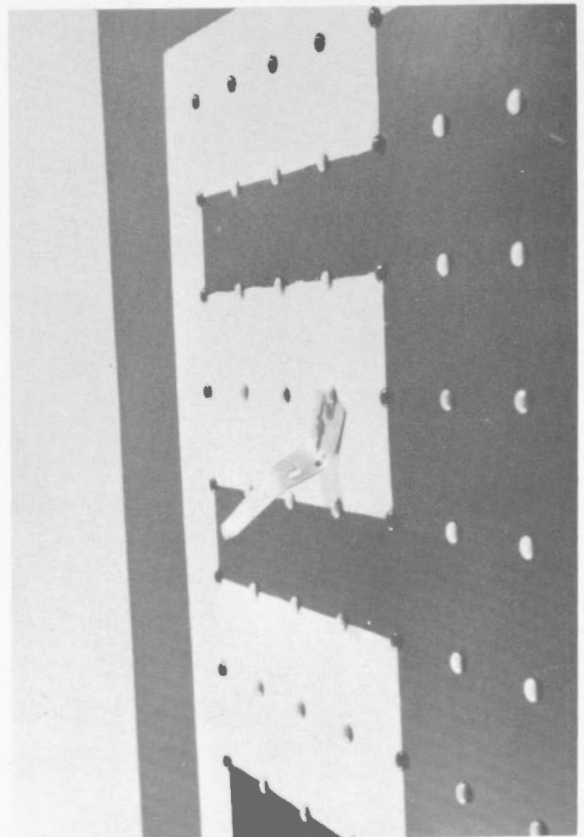

Fig. 74 High-speed Chronograph.



Fig. 75 Fixed Camera Placement for Record Photography.

Fig. 76 Record Mounting Board.



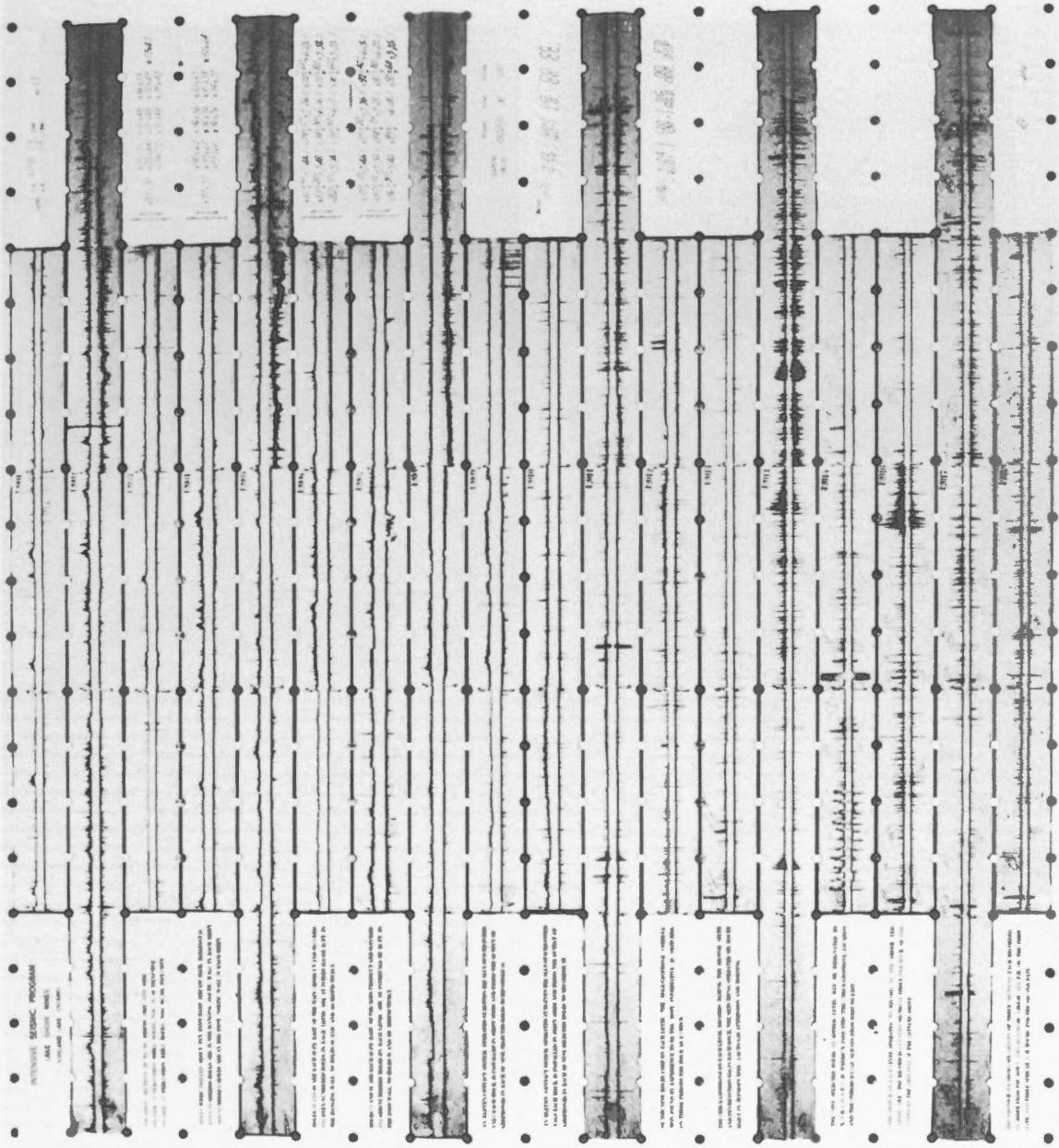

Fig. 77 Typical Daily Record: Intensive Seismic Program

Fig. 78 Traverse: Kirkland Lake to Ottawa.

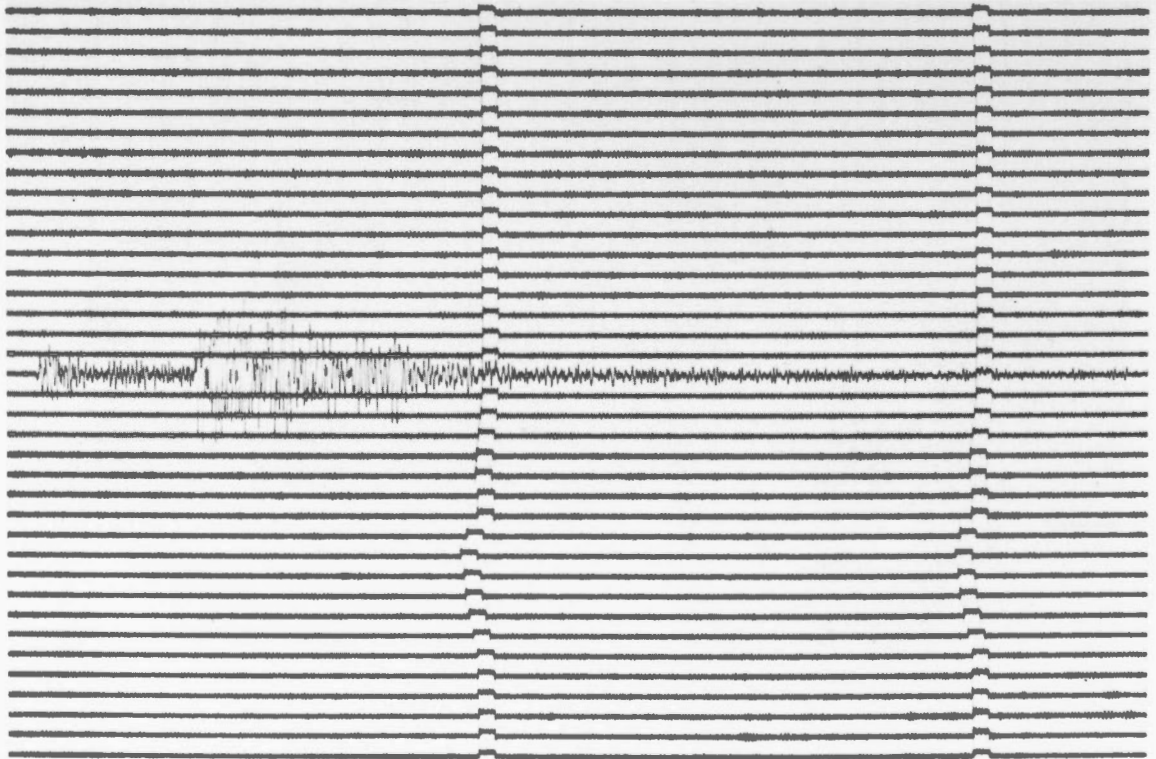
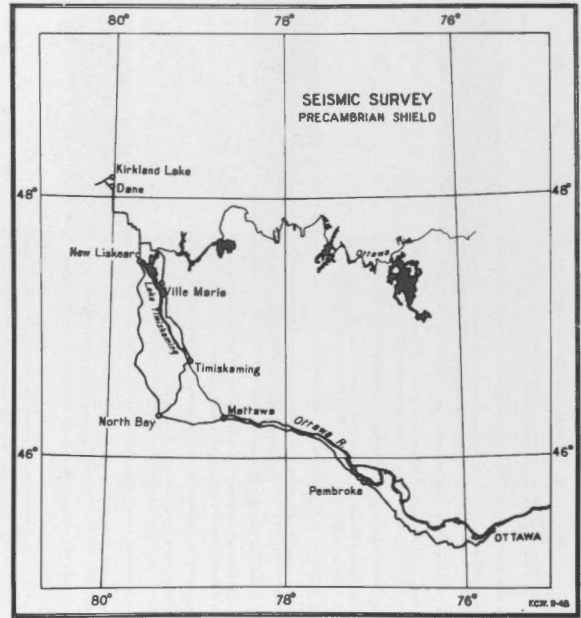

Fig. 79 Ottawa Benioff Record of a Rockburst in Northern New York State (102 mi.).

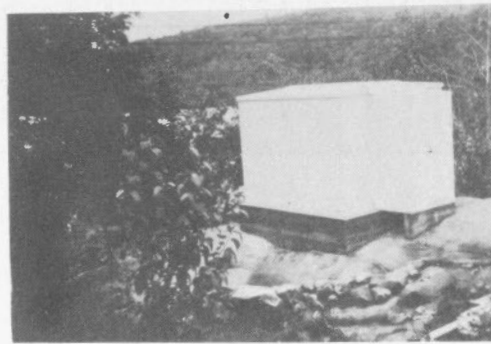
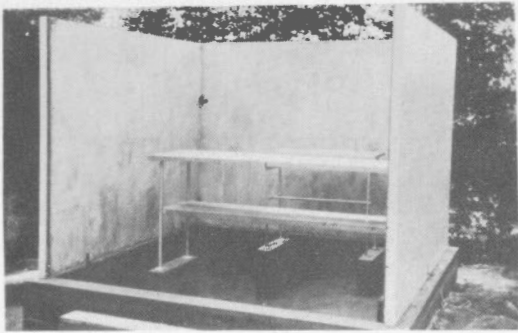
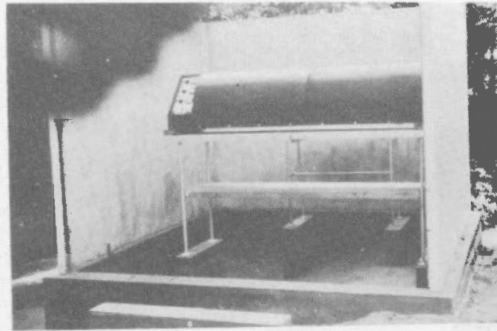
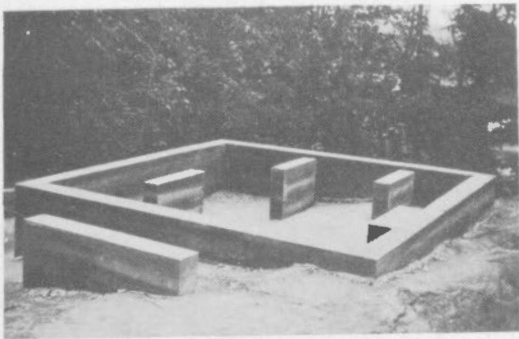
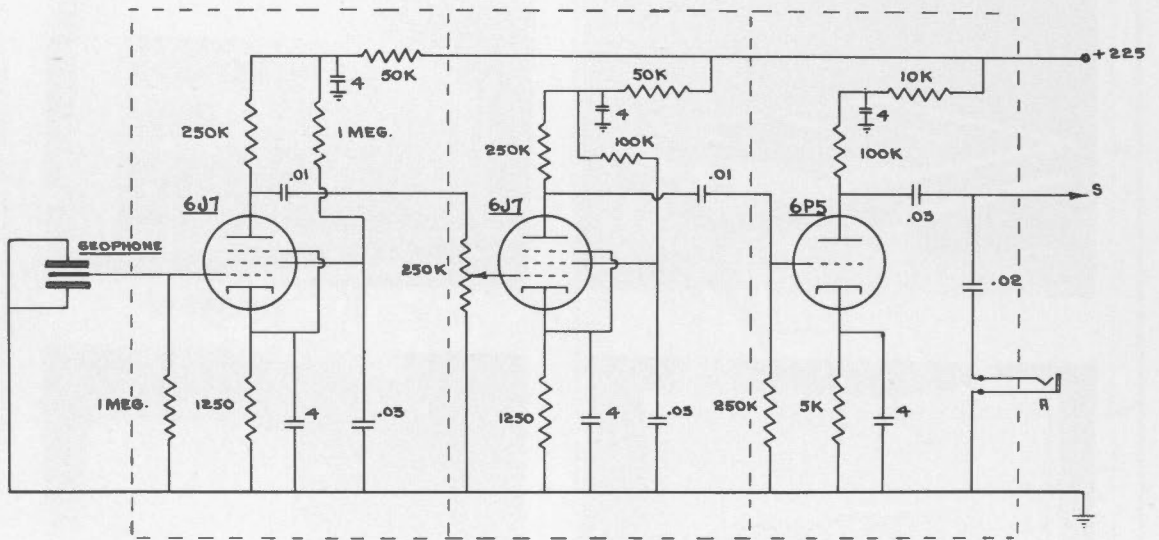

Fig. 80 Installation of Temporary Seismic Survey Hut.



Fig. 81 Permanent Seismograph Vault at Kirkland Lake.

MICROSEISMIC RECORDER — U.S. BUREAU OF MINES.



HIGH GAIN AMPLIFIER.

Fig. 82 Wiring Diagram: High-gain Amplifier, Obert Recorder.

MICROSEISMIC RECORDER — U.S. BUREAU OF MINES.

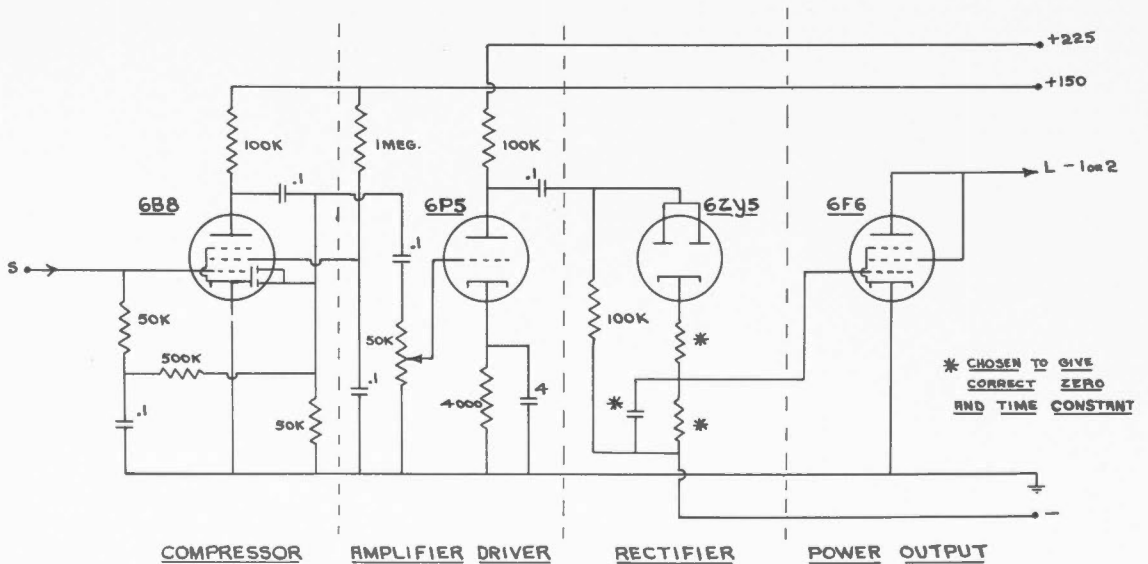

RECORDER AMPLIFIER

Fig. 83 Wiring Diagram: Recorder Amplifier, Obert Recorder.

MICROSEISMIC RECORDER — U.S. BUREAU OF MINES.

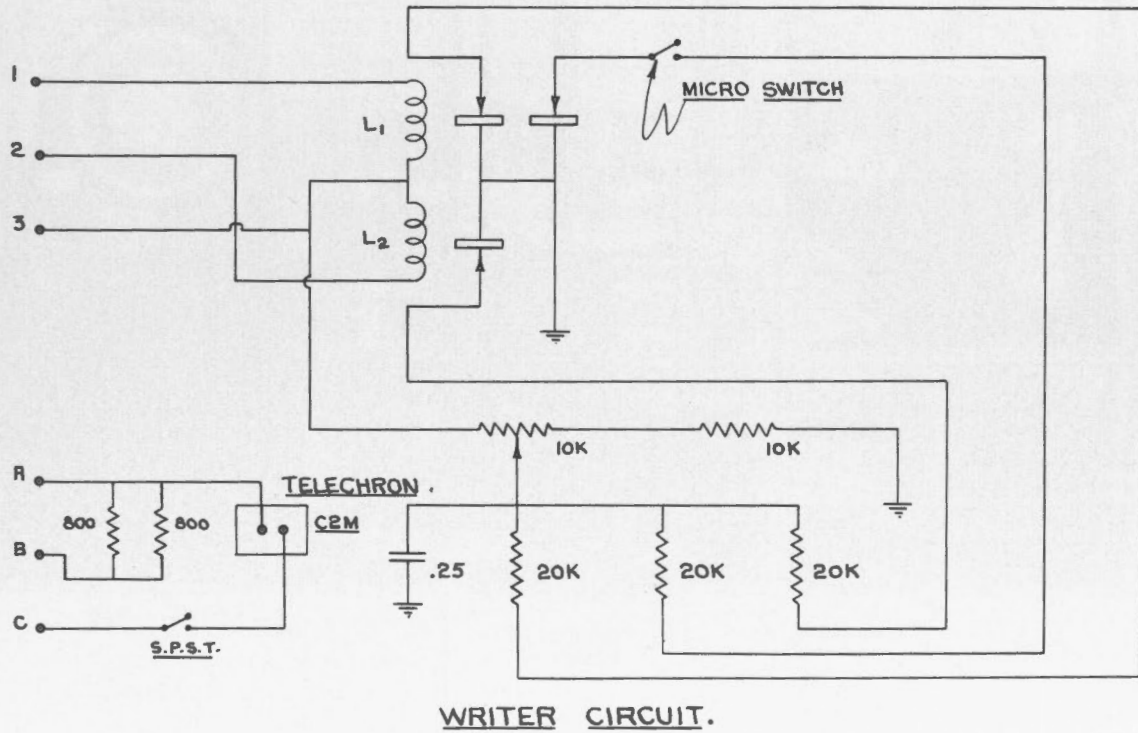

Fig. 84 Wiring Diagram: Writer Circuit, Obert Recorder.

MICROSEISMIC RECORDER — U.S. BUREAU OF MINES.

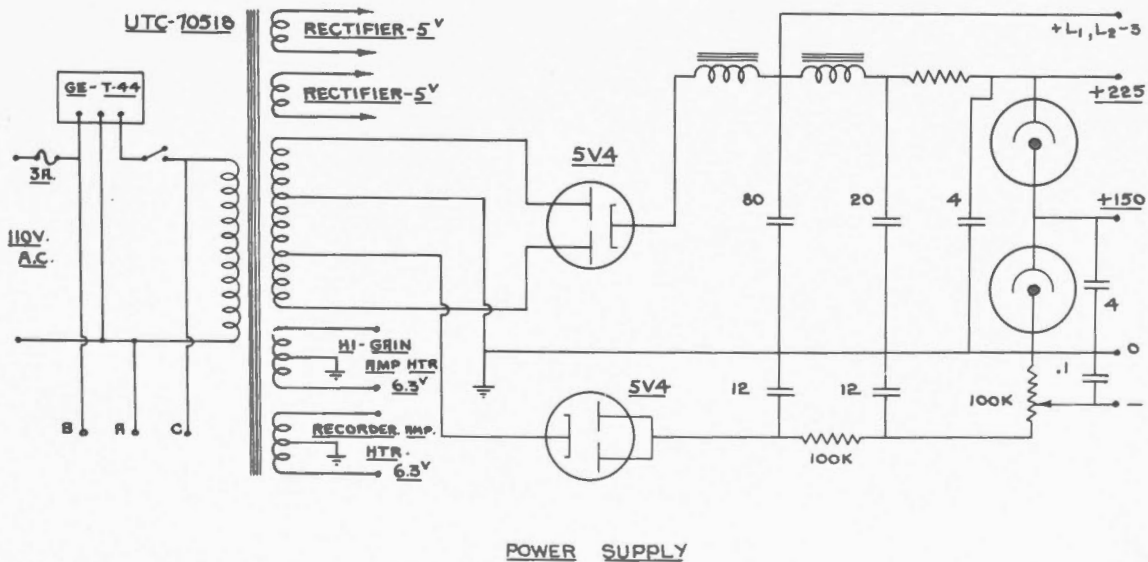

Fig. 85 Wiring Diagram: Power Supply, Obert Recorder.

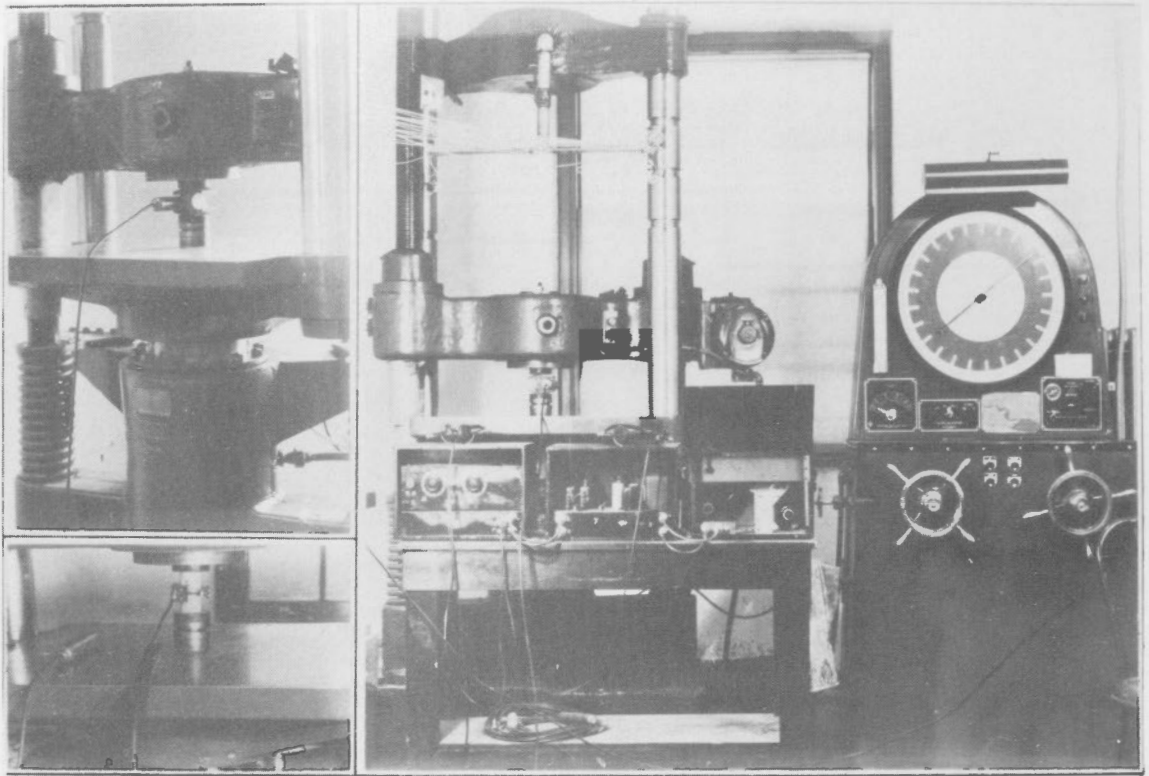

Fig. 86 Instrumental Set-up, College Park.

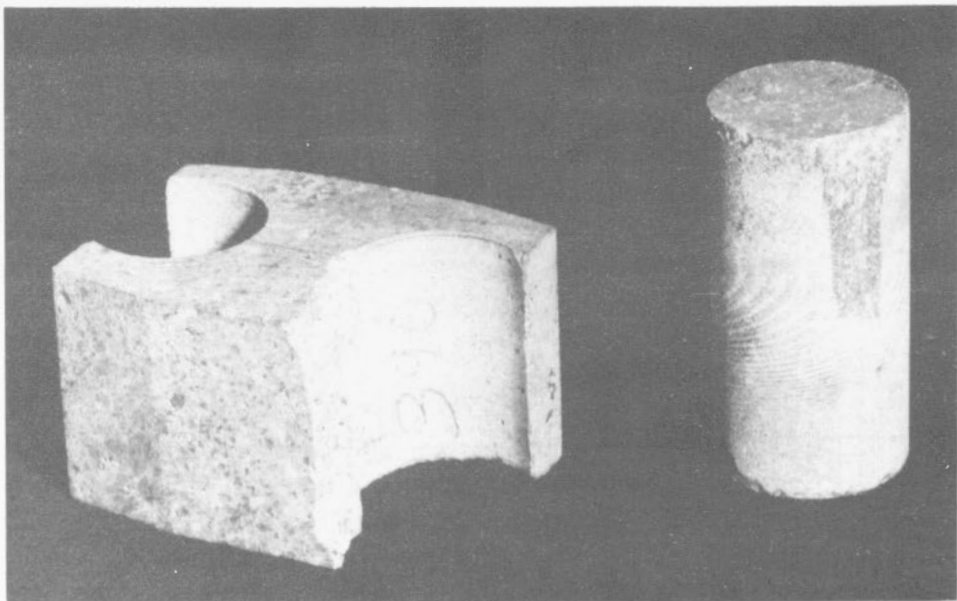

Fig. 87 X-shaped Specimen (Test 21; BM-390) and 2D Specimen

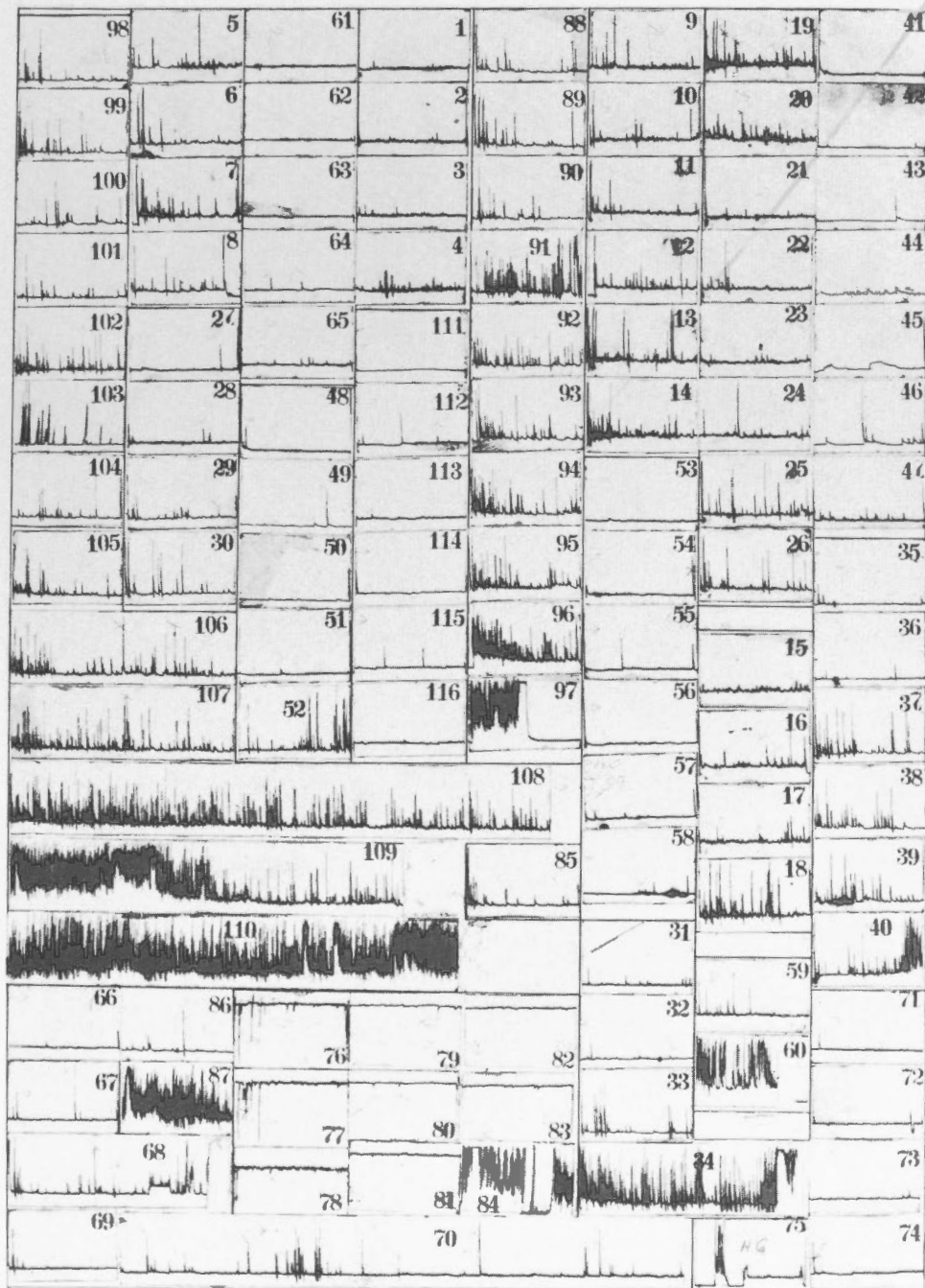

Fig. 88 Pressure Test Results, College Park.

THE QUEEN'S PRINTER AND CONTROLLER OF STATIONERY
OTTAWA, 1959