

1014868

This document was produced by scanning the original publication.

Ce document est le produit d'une numérisation par balayage de la publication originale.

14868

INFORMATION BULLETIN AIRBORNE OPERATION



Energy, Mines and Resources Canada

Énergie, Mines et Ressources Canada

Canada Centre for Remote Sensing

INFORMATION BULLETIN

AIRBORNE OPERATION

Third Edition

July 1977

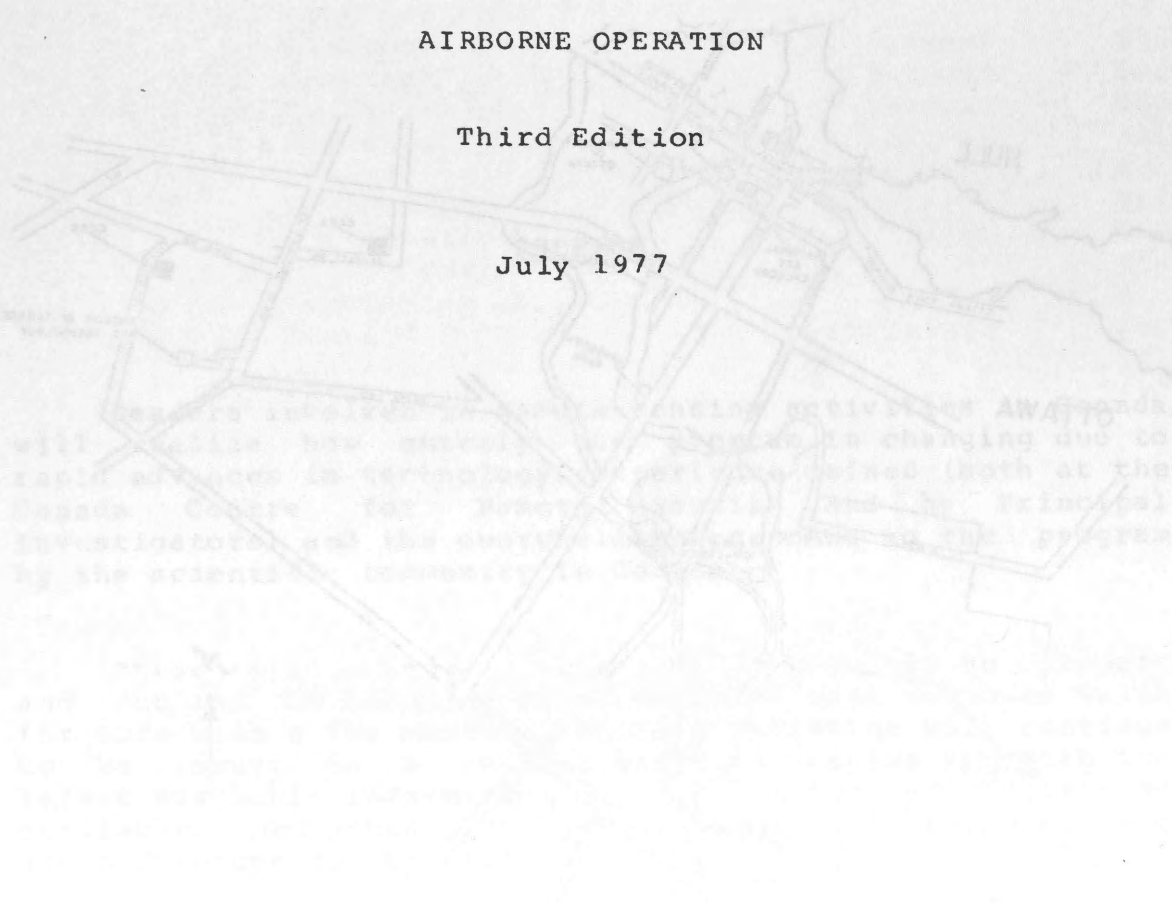

Produced by

Airborne Operations Section

Data Acquisition Division

Canada Centre for Remote Sensing

Department of Energy, Mines and Resources

Canada

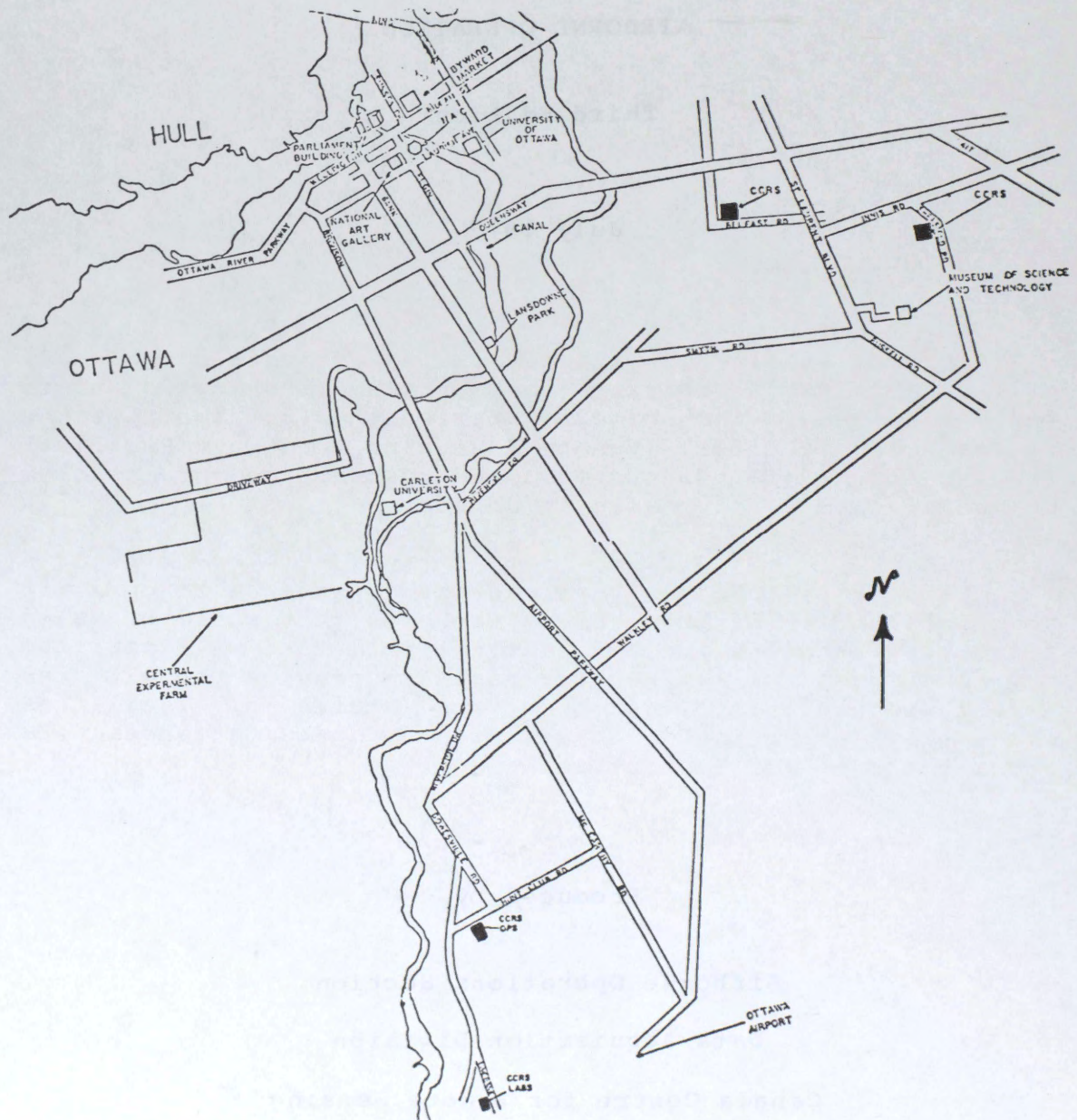

Figure 1 - Frontispiece

TABLE OF CONTENTS

Page	Section
1.1	Introduction
1.2	General
1.3	Airborne
1.4	Satellite
1.5	Ground
1.6	Data
1.7	Description
1.8	References
1.9	Index

PREFACE

Readers involved in Remote Sensing activities in Canada will realize how quickly the program is changing due to rapid advances in technology, experience gained (both at the Canada Centre for Remote Sensing and by Principal Investigators) and the overwhelming response to the program by the scientific community in Canada.

These rapid changes have made it impossible to prepare and publish an Airborne Users Handbook that would be valid for more than a few months. Interim Bulletins will continue to be issued on a regular basis to provide you with the latest available information on the status of facilities available, procedural changes, technological advances made and a forecast for the future.

TABLE OF CONTENTS

Section		Page
1.0	INTRODUCTION	9
1.1	General	9
1.2	Aircraft	9
1.3	Sensors	9
1.4	Material	9
1.5	Requests	10
1.6	Costing	10
1.7	Data	10
2.0	DESCRIPTION	12
2.1	General	12
2.2	Data Acquisition Division	12
2.2.1	Sensor Section	12
2.2.2	Airborne Operations Section	13
2.2.3	Systems Section	13
2.3	Airborne Sensing Unit	14
2.4	Innotech Aviation Limited	14
2.5	Aerial Photography Division, EMR	14
2.5.1	National Air Photo Library	14
2.5.2	National Air Photo Reproduction Centre	15
3.0	REQUEST SUBMISSION	16
3.1	Regional Committees	16
3.2	Request Procedures	17
3.2.1	Communications	17
3.2.2	Application and Objectives	17
3.2.3	Area of Operation	18
3.2.4	Map Sheets	18
3.2.5	Time Periods	18
3.2.6	Altitudes	19
3.2.7	Sun Angle	19
3.2.8	Percent Cloud	20
3.2.9	Primary Sensor	20
3.2.10	Overlap	20
3.2.11	Sensors and Material	21
3.2.12	Reproduction and Priorities	21
3.2.13	Delivery Instructions	23
3.2.14	Secondary Reproduction	23

Section	Page	
3.3	Sequence of Events	24
3.3.1	General	24
3.3.2	Submission	24
3.3.3	Examination	25
3.3.4	Liaison	25
3.3.5	Approval	25
3.3.6	Finalization	26
3.3.7	Revisions	26
3.3.8	Tasking	26
3.3.9	Scheduling	26
3.3.10	Notification	26
3.3.11	Flight Completion	27
3.3.12	Processing	27
3.3.13	Quality Control	28
3.3.14	Reproduction	29
3.3.15	Shipment and Invoicing	29
4.0	SENSOR PLATFORMS	31
4.1	DC-3 (Dakota) C-GRSB	31
4.2	DC-3 (Dakota) C-GRSA	34
4.3	Falcon Fan Jet C-GRSD	37
4.4	Convair 580 C-GRSC	40
4.5	Tethered Balloon	42
5.0	SENSORS	44
5.1	Vinten 70 mm Type 942	44
5.2	Wild Heerbrugg - RC-8	46
5.3	Wild Heerbrugg - RC-10	46
5.4	Hasselblad 500EL 70 mm	47
5.5	Barnes PRT-5	48
5.6	Barnes PRT-6	48
5.7	8-14 um versus 9.5-11.5 um	49
5.8	Daedalus Single Channel IRLS	51
5.9	Daedalus Dual Channel IRLS	52
5.10	Daedalus Imagery Processing	53
5.11	Temperature Coded Colour Daedalus Imagery	59
5.12	Tektronix J16 Radiometer	62
5.13	Exotech ERTS Radiometer	62

Section	Page
6.0	FILM 64
6.1	General 64
6.2	Plus X Aerographic Type 2402 64
6.3	Double X Aerographic Type 2405 65
6.4	Infrared Aerographic Type 2424 66
6.5	Ektachrome Aerographic Type 2448 66
6.6	Aerocolor Negative Type 2445 68
6.7	Aerochrome Infrared Type 2443 69
6.8	Special Purpose Films 70
7.0	FILTERS 72
7.1	General 72
7.2	Vinten Clear Glass 74
7.3	Vinten Minus Blue Glass 75
7.4	Vinten 500-600 nm Glass 76
7.5	Vinten 600-700 nm Glass 77
7.6	Vinten 700-800 nm Glass 78
7.7	Vinten 800-900 nm Glass 79
7.8	Wild Filters 80
7.9	Kodak Gelatin Filters 81
7.10	Transmittance - Aircraft Camera Hatch (DC-3) 82
7.11	Transmittance - Aircraft Camera Hatch (Falcon) 83
7.12	Transmittance - Aircraft Camera Hatch (Convair) 84
8.0	COST RECOVERY 85
8.1	General 85
8.2	Applicable Charges 86
8.2.1	Line Mile 86
8.2.2	Material Expended 87
8.2.3	Processing Original Imagery 87
8.2.4	Reproduction 87
8.2.5	Summary 87
8.3	User Calculations 88
8.4	Fiscal Year 1977/78 89
9.0	VISUAL LIBRARY 90
9.1	General 90
9.2	Data Retrieval 90

Section	Page
9.3 Visual Library	90
9.4 Reports	91
10.0 A LOOK TO THE FUTURE	92
10.1 Sensors	92
10.1.1 Microwave Scatterometer	92
10.1.2 Pulsed Laser Fluorosensor	93
10.1.3 CW Laser Fluorosensor	96
10.1.4 Lidar Bathymeter	97
10.1.5 Linear Detector Array Spectrometer	99
10.1.6 MPPH Four Barrel Photometer	100
10.1.7 Multispectral Line Scanner	102
10.1.8 MEIS	103
10.1.9 Gas Correlative Cell Spectrometer	104
10.1.10 Low Light Level Television	105
10.2 Systems	106
10.2.1 Airborne Data Acquisition System	107
10.2.2 Ground Recovery and Monitoring System	108
10.2.3 Inertial Navigation System (INS)	110
10.2.4 VLF Navigation System	111
10.2.5 Doppler Navigation System	112
APPENDIX A NAPL Price List	
APPENDIX B Scale and Coverage Data	
APPENDIX C Super-Wide Angle Cameras - Pro and Con	
APPENDIX D Image Motion Tables	
APPENDIX E Sun Angle Tables	
APPENDIX F Cost Estimating	
APPENDIX G Film Annotation	
APPENDIX H Sample Request and Task Sheets	
APPENDIX I Regional Centres	
APPENDIX J Infrared Radiometry	
APPENDIX K Miscellaneous Information	
APPENDIX L The Variability of Aerochrome Infrared Film	

INDEX

LIST OF ILLUSTRATIONS

Figure		Page
1	Frontpiece	2
2	DC-3 C-GRSB	33
3	DC-3 C-GRSA	36
4	Falcon C-GRSD	39
5	Convair 580 C-GRSC	41
6	Daedalus Level Slicing	53
7	Scanner Temperature Printout	58
8	2402 Spectral Sensitivity	64
9	2405 Spectral Sensitivity	65
10	2424 Spectral Sensitivity	66
11	2448 Spectral Sensitivity	67
12	2448 Spectral Dye Density	67
13	2445 Spectral Sensitivity	68
14	2445 Spectral Dye Density	68
15	2443 Spectral Sensitivity	69
16	2443 Spectral Dye Density	70
17	Vinten Clear Glass Spectral Transmission	74
18	Vinten Minus Blue Spectral Transmission	75
19	Vinten 500-600 nm Spectral Transmission	76
20	Vinten 600-700 nm Spectral Transmission	77
21	Vinten 700-800 nm Spectral Transmission	78
22	Vinten 800-900 nm Spectral Transmission	79
23	Wild Filters	80
24	Kodak Gelatin Filters	81
25	DC-3 Camera Hatch Spectral Transmission	82
26	Falcon Camera Hatch Spectral Transmission	83
27	Convair Camera Hatch Spectral Transmission	84
28	2443 - Characteristic Curves	C-6
29	Sample Cost Estimate Print-out	F-3
30	Spectral Distribution of Radiant Power from a Black Body	J-6
31	Infrared Atmospheric Transmission vs Wavelength	J-6
32	Radiated Energy vs Temperature for Blackbody Sources	J-6
33	Scanner Diagram	J-8
34	Typical characteristic curves of Type 2443 film of "normal" IR-balance	L-10
35	Curves of "normal" and "IR-enhanced" emulsions	L-11
36	Range of IR-balance of CCRS films	L-12

1.0 INTRODUCTION

1.1 General

Under the Program Planning Office, Resource Satellites and Remote Sensing, an Airborne Remote Sensing Program was instituted in 1970. One Department of National Defence owned CF-100 with a very limited sensor capability was flown that year in support of twelve projects. Personnel were few and inexperienced. Facilities were minimal.

1.2 Aircraft

At the present time the original CF-100 has been retired from service and the aircraft fleet has expanded to include two DC-3's, one Falcon Fan Jet and one Convair 580 -- all owned by the Department of Energy Mines and Resources. Aircraft are described in detail in Section 4 -- Sensor Platforms.

1.3 Sensors

The inventory of useful sensors has also been increased by the purchase of high quality photographic equipment including cameras, lenses and filters; plus sensors that provide data in other forms to meet specialized requirements. In addition, a number of sensors have been developed under Canada Centre for Remote Sensing funding. Some are being test flown this year and several others will be evaluated during the following season. Existing operational sensors are described in detail in Section 5 -- Sensors. Sensors under development are listed in Section 10 -- A Look to the Future.

1.4 Material

Experience of Canada Centre for Remote Sensing personnel plus assistance and advice from users have resulted in the procurement and standardization of film and filter combinations that satisfy the requirements of most

1.4 Material

Experience of Canada Centre for Remote Sensing personnel plus assistance and advice from users have resulted in the procurement and standardization of film and filter combinations that satisfy the requirements of most users. Detailed descriptions are contained in Sections 6 and 7 respectively.

1.5 Requests

The receipt, processing and actioning of requests have now been standardized. Submission procedures are detailed in Section 3 -- Request Submission. Request processing and action taken by various agencies are outlined in Section 2 -- Description.

1.6 Costing

To assist in the introduction of airborne remote sensing techniques to the scientific community of Canada, costs for services provided have been held to a minimum. Users have always paid for reproduction of final imagery. During 1973/74, federal agencies paid \$2.00 per sensor line mile and after July 1, 1973 a charge was levied for the processing of original film. In the 1974/75 season all users were charged \$5.50 per line mile. During 1975/76 this was increased to \$14.00 for federal government users, \$11.00 for other users and a special \$5.50 per line mile charge for first time users. In 1976/77 there was a further increase to \$18.00 a line mile for experienced users and \$9.00 for first time users. In addition a \$100.00 minimum line mile charge was implemented and an additional two line miles were added for each line over one line to help cover the costs of end turns. Details of present cost and invoicing procedures are contained in Section 8 -- Cost Recovery.

but unfortunately response has been generally disappointing. Details of the Data Acquisition Division "data bank" are contained in Section 9 -- Visual Library.

2.0 DESCRIPTION

2.1 General

Resources available within the Airborne Remote Sensing Program are committed to the support of research and development programs within the scientific community of Canada. Support requests emanate from federal and provincial government departments, universities and industry. They encompass research in many disciplines. Of equal importance is the "in-house" research into the development and flight testing of new sensors.

Correspondence with potential and active Principal Investigators reveals that there is some confusion over the functions of the various federal government agencies that provide a service to the public through the medium of the Airborne Remote Sensing Program. No attempt will be made in this publication to provide a detailed description of organization or line and staff functions. The following brief outline is presented as a general guide to the responsibilities of the various departments and sections involved in the program.

2.2 Data Acquisition Division

Data Acquisition Division (DAD), Canada Centre for Remote Sensing (CCRS), Department of Energy, Mines and Resources (EMR).

Offices, aircraft and laboratories of this Division are located in an operations hangar and a labs building at the north end of Ottawa International Airport. The chief is directly responsible to the director, CCRS. Main components of DAD are as follows:

2.2.1 Sensor Section -

The Sensor Section is responsible for the maintenance, calibration and modifications of existing airborne sensors; development, procurement, flight testing, evaluation and commissioning of new airborne sensors; and the setting up

of operational procedures and calibration facilities to support them.

2.2.2 Airborne Operations Section

This section is responsible for the receipt of flight requests from federal and provincial remote sensing agencies or individuals, resolving technical difficulties encountered, preparing a resume of the request for approval by the remote sensing committee and tasking the contractor (Innotech Aviation Limited) to perform flights on the approved projects. This Section is also responsible for the supply of operational sensors, film, magnetic tape and other expendable items used during flights; the co-ordination of the program in general. An additional responsibility is the production of imagery from taped Infrared Scanner data obtained during airborne operations and the provision of such imagery directly to users. This imagery is density sliced on request. (See Section 5.10)

A quality control section, formerly located at 2464 Sheffield Road has now moved to the operations hangar. This section reports directly to Airborne Operations and is responsible for quality control of imagery, indexing and annotation of imagery as required, raising of work orders for processing and reproduction, and submission of statistics for invoicing purposes.

2.2.3 Systems Section

The Systems Section is responsible for the servicing and maintenance of operational and experimental sensors; modification and updating of aircraft systems to accept new sensors; mount and control design, fabrication and installation.

2.3 Airborne Sensing Unit

The Canadian Forces Airborne Sensing Unit (CFASU), Department of National Defence (DND) was responsible for the operation, servicing and maintenance of all aircraft from 1970 to 1975. This unit was disbanded on November 1, 1975 and all of its services were taken over by Innotech Aviation Limited of Montreal.

2.4 Innotech Aviation Limited

This company was contracted by CCRS to provide flight crews, maintenance personnel, sensor operators and technicians for CCRS aircraft. These crews carry out all remote sensing flights as directed by CCRS Airborne Operations. Sensor operators and technicians are augmented on some occasions by DAD personnel. Crews maintain liaison with users in the field during actual flight periods and ensure that accurate records are compiled during each flight performed.

Flight and maintenance crews are made up of Innotech employees. Sensor operators and technicians are supplied to Innotech by Interra Environmental Consultants Limited of Calgary.

2.5 Aerial Photography Division, EMR

Aerial Photography Division, Topographical Survey Directorate, Surveys and Mapping Branch, Department of Energy, Mines and Resources. Two sections within this division perform functions essential to the Remote Sensing Program:

2.5.1 National Air Photo Library (NAPL)

Offices are located at 615 Booth Street, Ottawa. They are responsible for the archival storage of all original photographic imagery obtained on remote sensing flights and the receipt and actioning of all secondary orders for

reproduction from such imagery.

2.5.2 National Air Photo Reproduction Centre (NAPRC)

Offices and laboratories are located at 2464 Sheffield Road, Ottawa. This section is responsible for the processing of all original imagery to required specifications and the reproduction of imagery as requested by users.

3.0 REQUEST SUBMISSION

3.1 Regional Committees

NOTE

For a complete list of regional committees see appendix "I"

A number of provincial and regional committees have been formed in Canada to co-ordinate remote sensing activities within designated areas. Submission of flight requests through such a committee - if available - presents a number of advantages:

1. The committee can often provide assistance in advising users of sensors available, sensor packages suitable to meet specific requirements, scale, overlap and line mile calculations.
2. Some committees maintain a print library and can supply roll numbers of imagery available in the National Air Photo Library.
3. Requests from an area may be co-ordinated in such a way that one flight can supply useful imagery to a number of users.
4. Many small flights that could not normally be justified may be combined into a single major mission.

In areas not served by a regional committee, requests may be submitted directly to:

Canada Centre for Remote Sensing,
2464 Sheffield Road,
Ottawa, Ontario,
K1A 0Y7

Attn: Airborne Operations Section

Telephone: 993-0121 (Sheffield Road)
998-3101 (Operations Hangar)
Telex: 053-3777 (Sheffield Road)

3.2 Request Procedures

Projects may be submitted on the Airborne Remote Sensing Flight Request form or in letter form. The former is preferable as section headings ensure that all required information is included. A sample flight request form is shown in Appendix "H". Regardless of the type of submission made, the following points should be covered.

3.2.1 Communications

Telephone numbers of the Principal Investigator(s) must be included to permit rapid contact by CCRS Airborne Operations Section prior to commencement of the flight period. Telephone numbers of the Ground Truth Contact are necessary to permit contact by flight crews on arrival in the area. In all instances both business and home numbers should be included to permit contact during silent hours or on holidays. The inclusion of a reliable alternate contact by name and telephone number is also desirable. Please include your telex if available. Indicate any special requirement for extended periods of advance notice. Also indicate if there is NO requirement for pre or post flight notification. (See also 3.3.10)

3.2.2 Application and Objectives

Submissions should contain as much detail as possible covering the objectives of the project and the applications of data to be provided. Points covered should include an estimate of social or economic benefits that may be accrued through the use of remotely sensed data. Attachments or references to specific programs, published papers or articles are useful.

3.2.3 Area of Operation

The area, flight line or target should be clearly defined on an accompanying map. Please use a scale of 1:250,000 for altitudes of 11,000 feet and above, and 1:50,000 for altitudes below 11,000 feet. Areas should, where possible, be oriented to accommodate east/west flight lines. In some instances it may be wise to designate a prime target area that will provide pertinent data if time or weather precludes a flight over the complete area.

3.2.4 Map Sheets

NTS (National Topographic Series) map numbers of sheets used should be included to facilitate location of the area when only a portion of the map is submitted.

3.2.5 Time Periods

Maximum allowable flexibility in time periods is requested to allow for scheduling, adverse weather conditions, etc. Please indicate all time periods if repetitive flights are required.

NOTE

If the project is not flown during the requested acceptable time period, CCRS will assume that the task is cancelled unless the Principal Investigator requests an extension.

3.2.6 Altitudes

Maximum allowable flexibility in flight altitudes is requested to allow for weather or other restrictions. Altitude may be expressed as required scale if so desired. Note that some sensors and aircraft have altitude restrictions as follows:

1. Cameras - Altitudes below 500 feet using a 3 inch lens or 1000 feet using a 6 inch lens will cause a loss of resolution due to image motion. (See Appendix "D" -- Image Motion Tables)
2. Daedalus IR Scanner - Limited to a minimum altitude of 500 feet at 120 knots (DC-3) and 500 feet at 140 knots (Falcon). Altitudes below 1100 feet (DC-3) and 1400 feet (Falcon) will result in some loss of information due to gaps between scan lines.
3. PRT-5 - Quantitative data doubtful above 8000 feet.
4. In all cases the safety of the aircraft is the prime consideration in determining the minimum altitude at which a project can be flown.

3.2.7 Sun Angle

Requestors should carefully consider the effect of sun angle on photographic coverage requested. The acceptance of a low sun angle is desirable as it provides maximum flexibility in scheduling by extending the useful daily flying period and often permits the performance of early morning flights under conditions of minimum turbulence and maximum visibility. However, low sun angles - 20 degrees or less - produce deep shadows in forested and/or hilly areas which may obscure required information. On the other hand a low sun angle can enhance geological features on land and reduce glare under certain water surface conditions (to avoid all specular reflection, a 45 degree maximum sun angle is required with a 6 inch lens). Thermal emissions recorded by infrared line scanners are of course directly affected by solar heating and pre-dawn or night flights with the scanner only may be desirable in some instances. Night flights in

remote areas are extremely difficult to perform due to lack of visual references and should only be requested if suitable area marking such as flare pots or ground lights can be pre-positioned, or if the aircraft is equipped with suitable navigation equipment such as an inertial navigation system. For more complete sun angle information see Appendix "E" -- Sun Angle Tables.

3.2.8 Percent Cloud

The percentage of cloud cover acceptable must be left to the discretion of the Principal Investigator. It should be remembered that 10 percent cloud cover often results in an additional 10 percent of the ground being obscured by cloud shadow which, on colour film, usually obscures surface detail. Most requestors accept between 10 and 20 percent cloud cover. It should be noted that overly stringent weather requirements may delay or prevent the completion of a project.

3.2.9 Primary Sensor

Flight line spacing will normally be calculated for the sensor stated to give complete area coverage. (See 3.2.10) In addition, invoicing will be based on the performance of the primary sensor.

3.2.10 Overlap

Standard overlaps used in calculations are 30 percent sidelap and 60 percent forward overlap. The 30 percent sidelap is used in all cases of multiple parallel flight lines to ensure area coverage. 60 percent forward overlap is used where stereo coverage is requested. 20 percent forward overlap is used where track identification only is desired. Some consideration should be given to the selection of forward overlap on 70 mm coverage at low altitudes. For example: When equipped with a three inch lens and flown at 2000 feet, each camera will produce in 100 nautical miles:

1. 760 exposures at 60 percent overlap.
2. 380 exposures at 20 percent overlap.

Consideration should also be given to the problem of flight line spacing when requesting the 70 mm camera as the primary sensor. The flight line spacing at lower altitudes may be such that precise navigation is impossible and could result in some loss of data. (at 2000 feet using a 3 inch, 70 mm camera, the line spacing is only 800 feet.) Selected flight lines within an area of interest or the use of a wide angle (9" X 9") camera as primary sensor could resolve this problem.

3.2.11 Sensors and Material

It is realized that many users are not familiar with the technical details and capabilities of aircraft and sensors. Information on aircraft, sensors, films and filters are contained in applicable sections. Requestors should complete as much of the request form, or provide as many pertinent details in a letter as possible when they submit their request. Regional committees or CCRS staff will be happy to assist or advise in the completion of technical details.

3.2.12 Reproduction and Priorities

The various standard types of reproduction available are:

1. Individual contact paper prints.
2. Individual contact transparencies.
3. Continuous contact paper prints.
4. Continuous contact transparencies.

Individual reproductions are generally of a higher quality than continuous reproductions. They are also more expensive. Continuous reproductions can only be done on an entire roll or a large portion of a roll (minimum 25 feet). 70 mm continuous enlargements to 9 in. X 9 in. are also available. For 70 mm imagery, individual reproductions are done in strips of four frames each. (See Appendix "A" -- NAPL Price List) The request for reproduction may also be deferred until after the Principal Investigator has viewed the original imagery.

Priorities will be established at the time the project request is accepted. These priorities are:

1. If imagery is required within three working days of the flight the project will be allotted a number one priority. Original unannotated imagery will be shipped air-express collect (at the discretion of CCRS) to the user or it will be made available at the CCRS Operations Hangar for perusal by the user. A number one priority will be allotted only under very special circumstances and, as with all priorities, will be established at the time the project is accepted. Users holding original film under this priority are expected to return it to CCRS for indexing and annotation within a period of one month. Extensions to this period may be granted under special circumstances. Upon return to CCRS, the original film is indexed and annotated on a priority four basis. It is then turned over to NAPL for storage. Any additional orders for reproduction of this imagery should be directed to NAPL.
2. Priority number two will provide a package consisting of a roll print from each requested roll within five working days. Imagery will not be annotated or indexed; quality of colour printing will be inferior to that normally produced by the step and repeat system, as control is limited on the roll printer. After printing is completed, original film will be normally indexed and annotated. As with priority number one, all additional requests for reproduction should be sent directly to NAPL.

This applies to photographic reproductions only.

3.3 Sequence of Events

3.3.1 General

To ensure that all readers are aware of the responsibilities of each section involved in the Airborne Operations Program, a sequence of events for the execution of a typical task is described as follows:

3.3.2 Submission

The Principal Investigator submits a request for a remote sensing flight through his regional office or direct to:

Canada Centre for Remote Sensing,
2464 Sheffield Road,
Ottawa, Ontario,
K1A 0Y7

Attn: Airborne Operations Section

Telephone: 998-3101

Telex: 053-3777

3.3.3 Examination

Requests for airborne remote sensing flights are examined in detail to ensure that the task:

1. Falls within the CCRS terms of reference. i.e. is experimental or research, will probably result in social or economic benefit to Canada, cannot be performed by industry, etc.
2. Is within the capabilities of the sensors and sensor platforms available.

3. Does not conflict with other scheduled tasks.

3.3.4 Liaison

Contact is established with the Principal Investigator by telephone, through correspondence and by meetings. Each detail of the request is confirmed. i.e. some changes to flight altitude, time, sensor package etc. may be required to accommodate facilities or scheduling.

3.3.5 Approval

When it has been established that both parties (Principal Investigator and CCRS Airborne Operations) are agreed on all details of the task, a task "package" consisting of a task sheet and flight map is prepared for presentation to the CCRS approval committee. The task sheet (EMR 801 -- see Appendix H) has been revised to provide an itemized cost estimate and it constitutes a formal contract between all parties. Rejection or revision of the task by the approval committee results in immediate notification and/or negotiation with the Principal Investigator. This may result in revisions to the task and re-submission for approval.

3.3.6 Finalization

On receipt of approval, the task sheet is forwarded in two copies to the Principal Investigator for his signature and the insertion of a file or requisition number or other authority that may be quoted on an invoice from CCRS. The Principal Investigator's signature indicates that he understands all conditions of the task including the estimated cost. The requisition number should prevent a recurrence of invoicing problems previously encountered.

3.3.7 Revisions

Revisions to projects as originally tasked will automatically result in the preparation of a new tasking form. Revisions in the field may be made at the discretion of the Principal Investigator and the flight crews involved but must be covered by a statement of agreement signed by both parties.

3.3.8 Tasking

CCRS Airborne Operations passes a copy of the signed task sheet to the flight crews as an order to fly the task. Further briefings on specific details are provided to the crews on an as-required basis at any time prior to the flight. It is often necessary to re-check some details with the Principal Investigator. A sample task sheet is shown in Appendix "H".

3.3.9 Scheduling

Scheduling is controlled to allow the maximum number of projects to be completed in any area with a minimum expenditure of transit miles.

3.3.10 Notification

By telecon or telex, CCRS Airborne Operations notifies the Principal Investigator (through a regional centre if possible) of the time period within which he can expect the aircraft to be in his designated area. This is usually done just prior to the deployment of the aircraft to that area. It is the responsibility of the aircraft crew to notify the Principal Investigator, if required, of the specific date and hour of the flight. If for any reason the flight cannot

be performed, every attempt is made to notify all applicable parties.

NOTE

If the Principal Investigator has indicated that pre-flight notification is necessary and the crew is unable to contact him or his designated representative prior to the flight, the project will NOT be flown. This should perhaps be taken into account when requesting pre-flight notification.

3.3.11 Flight Completion

On the completion of a successful flight, all film, tape, charts and documentation are shipped to CCRS Airborne Operations by the fastest available means.

3.3.12 Processing

CCRS Airborne Operations raises a work order for film processing which accompanies the film to the National Air Photo Reproduction Centre (NAPRC). Magnetic tape is retained and immediately reduced to hard copy. NAPRC processes the film and forwards resulting imagery to CCRS Airborne Operations Quality Control (AOQC). The imagery is then forwarded with applicable documentation directly to the Principal Investigator.

3.3.13 Quality Control

AOQC performs the following functions:

1. Checks the quality of all original imagery.
2. Disposes of unsuitable imagery and notifies the Principal Investigator of the action taken.
3. Indexes and annotates imagery as required.
4. Determines the percentage of the task completed.
5. Raises a work order to NAPRC for the required reproduction.
6. Checks the quality of all reproductions and ships them to the Principal Investigator.
7. Raises an invoice to the Principal Investigator for all applicable charges.

NOTE

Airborne Operations Quality Control is the direct contact for information regarding film processing, delivery, reproduction status, etc. Inquiries should be directed to:

Canada Centre for Remote Sensing,
2464 Sheffield Road,
Ottawa, Ontario,
K1A 0Y7

Attn: Air Ops Quality Control

Telephone: 998-3101
Telex: 053-3777

3.3.14 Reproduction

NAPRC performs the reproduction functions, places originals in storage and forwards reproductions to AOQC for verification and quality control.

3.3.15 Shipment and Invoicing

AOQC ships imagery to the Principal Investigator and prepares an invoice. The invoice will be raised against the order number shown on the task sheet and will include:

1. Task number
2. Purchase order number (if available)
3. Date flown
4. Total agreed charges as per task sheet
5. Any deductions for work not carried out
6. Net charge

NOTE

Line mile charges will be those stipulated in this bulletin. Material charges will be at current CCRS cost. Film processing, reproduction and handling charges will be as stipulated by NAPL. (Price list is attached as Appendix "A".)

NAPL invoices CCRS for film processing and reproduction charges. CCRS receives payment from the Principal Investigator and disburses funds to applicable accounts - NAPL and Receiver General.

It should be noted that the above sequence of operations applies only to imagery obtained, processed and reproduced in accordance with instructions contained in the task sheet raised for each project. Orders for additional photographic imagery must be placed directly with NAPL who will perform all functions and invoice accordingly. As previously explained, re-orders for original data from magnetic tape should be placed directly with CCRS Airborne Operations.

4.0 SENSOR PLATFORMS

4.1 DC-3 (DAKOTA) C-GRSB

Description: Transport type aircraft having two Pratt and Whitney reciprocating engines. Two pilots are mandatory and an additional five or six sensor operators may be carried.

Performance: Operational ceiling -- 10,000 feet (Note)
Flight Duration -- 8 hours
Range -- 1,200 nautical miles
True Airspeed -- 120 - 150 knots

Sensor Locations: All sensors are located aft of the wing-root and are completely accessible during flight.

Sensor Control: Sensor controls are grouped on two consoles providing rapid access to monitor scopes, chart recorders, etc.

Support Systems: 14 channel Mincom Tape Recorder
Closed circuit television and video tape recording system
Navigation -- Tacan, ADF, provision for INS, VLF, and Doppler
Communication -- UHF, VHF, HF
APU -- Gas operated for ground power and internal engine starting.

Sensor Complement - Present: Four identical camera ports are available. Each port will accept either four Vinten 70 mm cameras, one Wild RC-10 9" X 9" camera with 3.46 inch or 6 inch lens cone, one RC-8 9" X 9" camera with 6 inch lens cone or a Daedalus Infrared Linescanner. The package carried may therefore contain any one or any combination of the above sensors. In addition one PRT-5 Infrared Radiometer may be carried.

Sensor Complement - future: Any existing sensor may be

replaced by sensors described in Section 10 -- A Look to the Future.

NOTE

Due to lack of an adequate oxygen system for the sensor operators this aircraft's maximum operating altitude is 10,000 feet ASL. (12,000 feet ASL for a maximum of thirty minutes.)

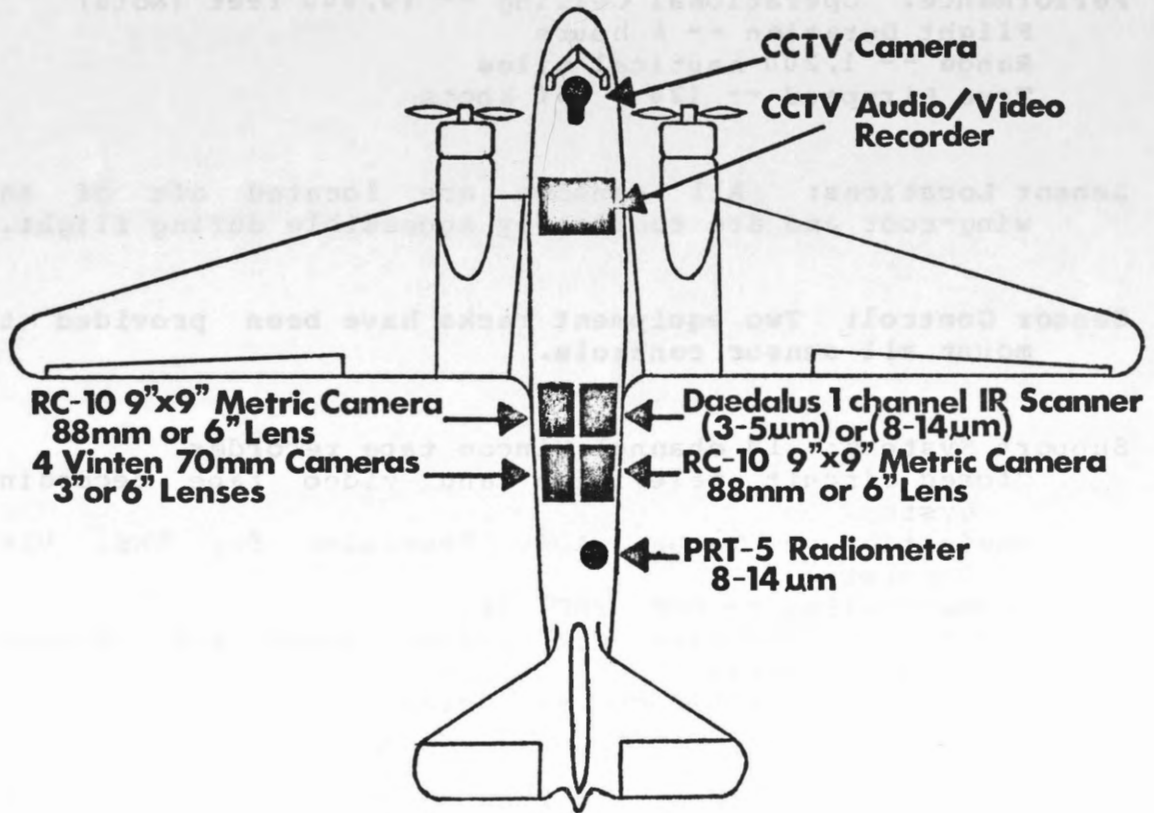

Dakota C-GRSB

Figure 2 -- DC-3 C-GRSB

4.2 DC-3 (DAKOTA) C-GRSA

Description: Transport type aircraft having two Pratt and Whitney reciprocating engines. Two pilots are mandatory and an additional five or six sensor operators may be carried.

Performance: Operational Ceiling -- 10,000 feet (Note)
Flight Duration -- 8 hours
Range -- 1,200 nautical miles
True Airspeed -- 120 - 150 knots

Sensor Locations: All sensors are located aft of the wing-root and are completely accessible during flight.

Sensor Control: Two equipment racks have been provided to mount all sensor controls.

Support Systems: 14 channel Mincom tape recorder
Closed circuit television and video tape recording system
Navigation -- Tacan, ADF, Provision for INS, VLF, Doppler
Communication -- UHF, VHF, HF
APU -- Gas operated for ground power and internal engine starting
Provision for ADAS Support System

Sensor Complement - Present: This aircraft is modified to accept all standard sensor packages. As it is dedicated to experimental work and sensor testing, no standard package can be described. It will eventually be fitted with a variety of sensors as described in Section 10 -- A Look to the Future.

NOTE

Due to lack of an adequate oxygen system for the sensor operators this aircraft's

maximum operating altitude is
10,000 feet ASL. (12,000 feet
ASL for a maximum of thirty
minutes.)

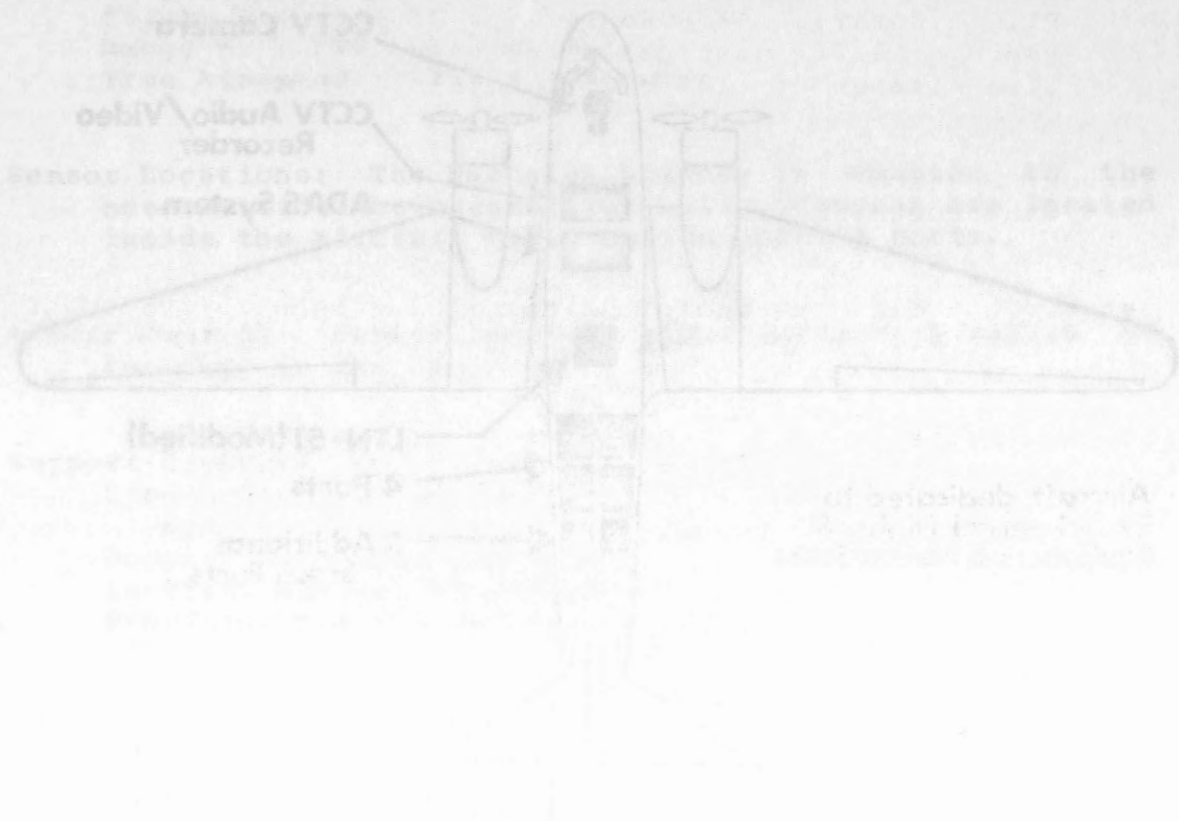

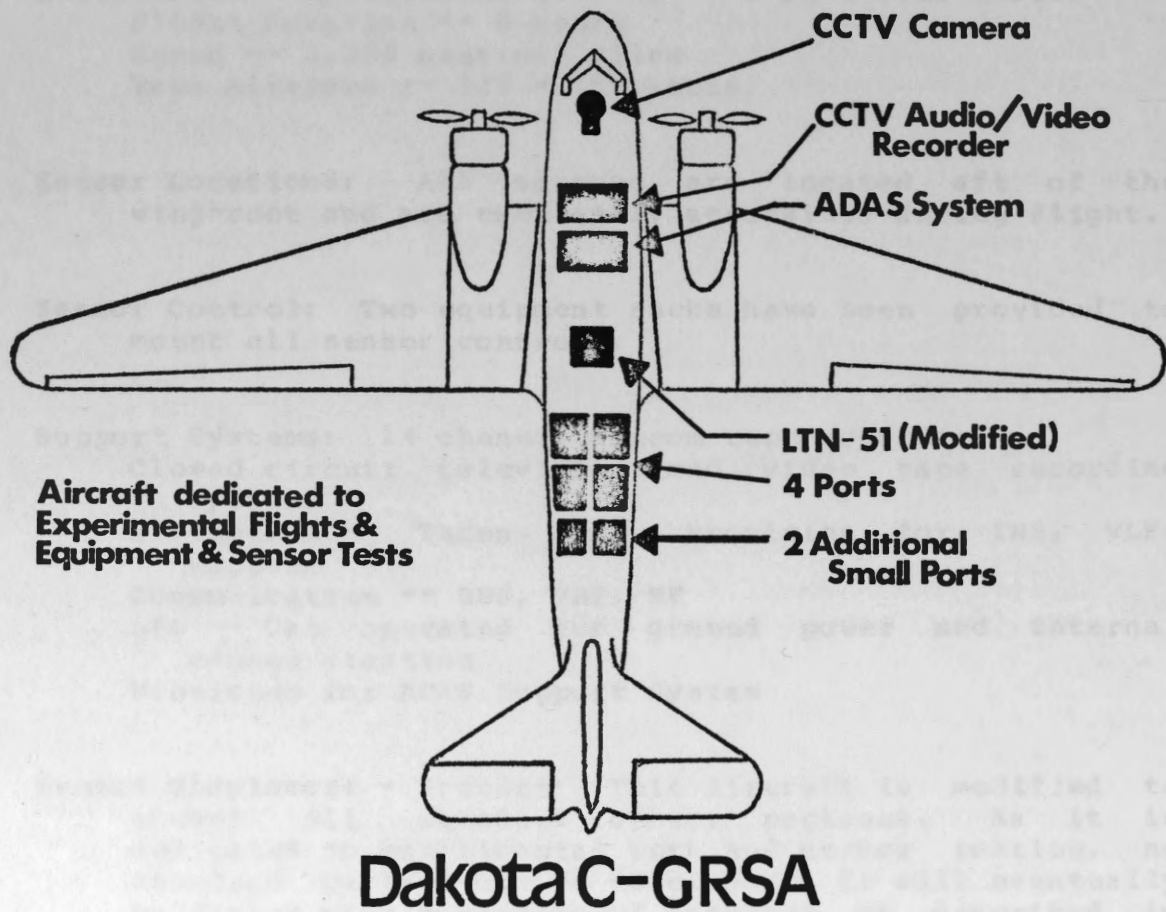

Figure 3 -- DC-3 C-GRSA

4.3 Falcon Fan Jet C-GRSD

Description: Executive transport type aircraft manufactured by Dassault (France). It has two fan-jet engines and carries two pilots and four or five sensor operators.

Performance: Operational Ceiling -- 36,000 feet ASL (stable platform)

Flight Duration -- 2.5 to 3 hours

Range -- 1,500 nautical miles

True Airspeed -- 250 - 400 knots

Sensor Locations: The Daedalus Scanner is mounted in the nose outside the pressurized hull. Cameras are located inside the aircraft cabin behind special ports.

Sensor Control: Sensor controls are grouped on a series of consoles in the cabin.

Support Systems: 14 channel Mincom Tape Recorder
Closed circuit television and video tape recording system

Doppler Navigation System

Inertial Navigation System

Provision for VLF Navigation System

Sensor Complement - Present: The basic sensor package consists of the Daedalus Infrared Scanner with recording facilities for two channels plus the PRT-5 radiometer. In addition any two of the optical sensors listed below may be carried and operated singly or simultaneously with the above package.

1. RC-10 9" X 9" camera with either a 3.46 inch or a 6 inch lens.
2. RC-10 9" X 9" camera with a 6 inch lens only.

3. Four Vinten 70 mm multispectral pack with 3 inch matched lenses and filters.

Sensor Complement - Future: Some existing sensors may be replaced in the future by items described in Section 10 -- A Look to the Future.

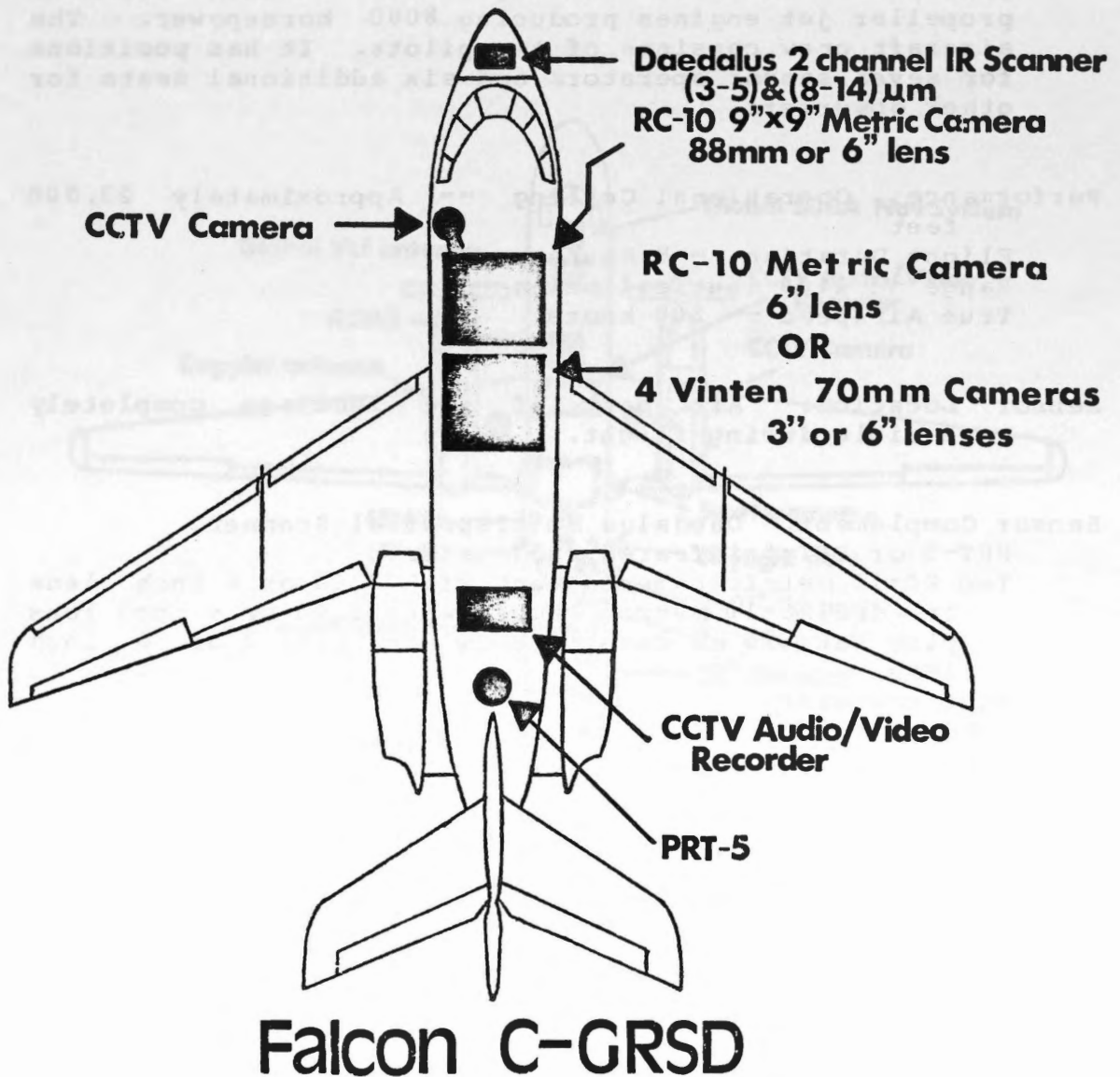

Figure 4 -- Falcon C-GRSD

4.4 Convair 580 C-GRSC

Description: The Convair 580 is a former passenger transport aircraft having two Allison 501-d13d propeller jet engines producing 8000 horsepower. The aircraft crew consists of two pilots. It has positions for seven sensor operators and six additional seats for other observers.

Performance: Operational Ceiling -- Approximately 23,000 feet
Flight Duration -- 8 hours
Range -- 2400 nautical miles
True Airspeed -- 300 knots

Sensor Location: Aft part of the fuselage completely accessible during flight.

Sensor Complement: Daedalus Multispectral Scanner
PRT-5 or PRT-6 infrared radiometer
Two RC-10 metric cameras each with 3.46 or 6 inch lens or one RC-10 metric camera with 3.46 or 6 inch lens plus four 70 mm cameras each with 1.5, 3 or 6 inch lens.
Scatterometer

Support Systems: Wild NF-22 drift sight
14 channel Mincom Tape Recorder
Closed circuit colour television and video tape recording system.
Doppler Navigation System
VLF Navigation System
Inertial Navigation System
Radar Altimeter
Status: Expected to be operational for the 1977/78 season.

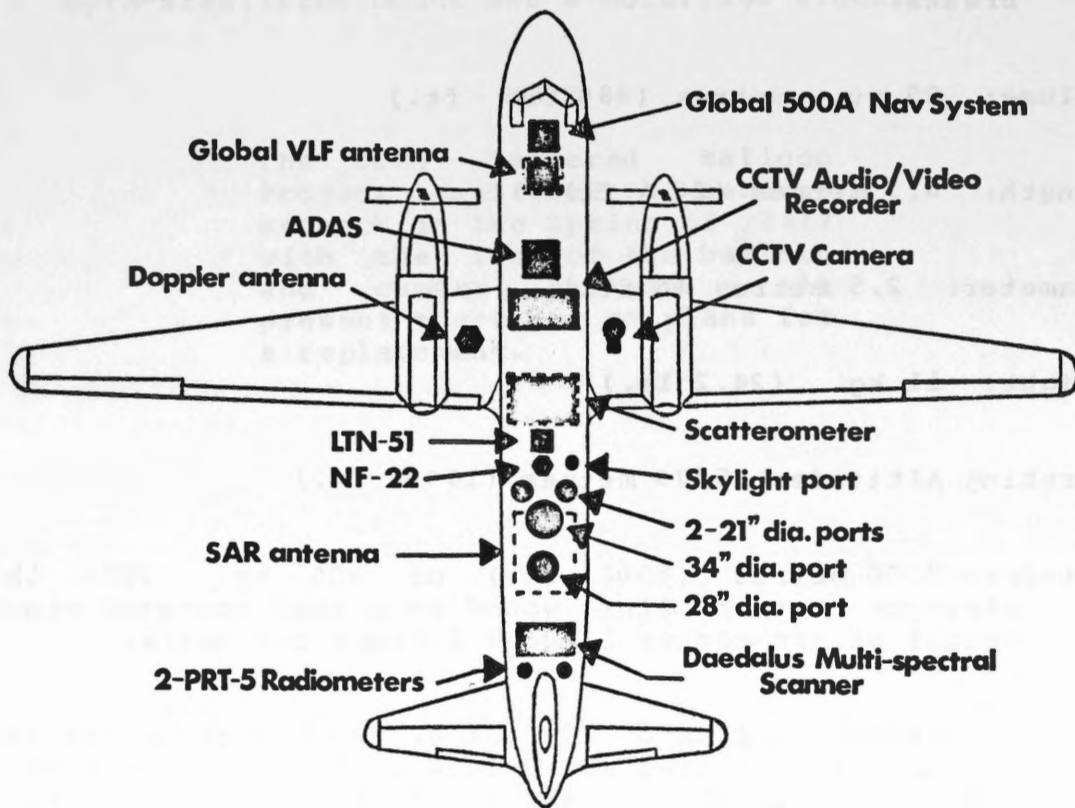

Convair C-GRSC

Figure 5 -- Convair 580 C-GRSC

4.5 Tethered Balloon

Description: Fire-orange, zeppelin shaped, helium-filled balloon made of 2-mil polyurethane with rigid tail vanes. The balloon is equipped with a radio-controlled 70 mm camera in a gimbal mount. A safety valve automatically deflates the balloon if the tether line breaks.

Volume: 25 cu. metres (880 cu. ft.)

Length: 8.3 metres (26.6 ft)

Diameter: 2.5 metres (8 ft.)

Weight: 11 kg. (24.2 lb.)

Bursting Altitude: 5000 metres (16000 ft.)

Tether: 2000 metres (6500 ft.) of 300 kg. (660 lb.) strength tether line wound on a hand operated winch. Weight of the tether line is 2 grams per metre.

Tether Markers: 6 inch by 10 foot orange streamers attached to the tether line at 50 foot intervals commencing at 150 feet below the balloon to 150 feet above the winch.

Maximum Wind: 30 knots

Maximum Lift: greater than 50 lbs.

Sensor Package: One motorized Hasselblad 70 mm camera with either a 40 mm or 80 mm focal length lens and a 100 foot film magazine. The camera is mounted in a gimbal mount suspended 50 feet below the balloon.

Sensor Control: The camera is radio controlled from a transmitter and intervalometer on the ground.

Sensor Complement - Future: Possible addition of a second Hasselblad, a 70 mm four lens multispectral camera, a multispectral photometer, a television camera, a gyro-stabilized mount and a motorized winch.

NOTE

The CCRS Tethered Balloon Project suffered a serious setback in the Spring of 1977 with the loss of the balloon and camera package. At present there are no plans for a replacement.

5.0 SENSORS

5.1 Vinten 70mm Type 492 (modified)

Format Size: 2 inch wide X 2.25 inch long (line of flight)

Lens: 6 inch - f 2.8, 3 inch - f 2.0, or 1.5 inch - f 2.8

Shutter Speed: 1/500 second

Cycle Rate: .5 to 999 seconds pulse mode

Film Supply: Magazine - vacuum back

Film Capacity: 70 mm X 150 feet black and white estar base
- 700 exposures; or 70 mm X 100 feet colour estar base
- 460 exposures

Spectral Characteristics: Dependent on film filter
combination used

Filters: Most commercially available glass and/or gelatin
filters including HF and CC series. Special glass
filters to match ERTS bands. NAV filters available for
1.5 inch lenses. See Section 7 -- Filters.

Spatial Characteristics: 20-25 lines per mm. (low contrast
annular target) Airtest using medium speed pan film and
normal processing.

Physical Parameters Measured: Solar reflected energy of
earth features

Available: 10 - camera bodies, 5 back track bodies, 8 - 3
inch lenses, 4 - 6 inch lenses, 4 - 1.5 inch lenses.

5.2 Wild Heerbrugq - RC-8

Description: Aerial survey camera

Format Size: 9 inch X 9 inch (23 cm X 23 cm)

Lens: 6 inch - f 5.6 Aviogon (UAG)

Shutter Speed: 1/100 to 1/700 second - continuously
variable

Cycle Rate: 1 cycle per 3.5 seconds - maximum

Film Supply: Magazine having a vacuum platen and an
integral vacuum pump

Film Capacity: 9 inch X 250 feet black and white estar base
- 280 exposures; or 9 inch X 200 feet colour estar
base - 225 exposures

Spectral Characteristics: Dependent on film/filter
combination used

Filters: Neutral AV 2.2
500 AV 1.4
540 AV 2.2
700 AV 1.4

Spatial Characteristics: 25 plus lines per mm. (low
contrast annular target) Airtest using medium speed pan
film and normal processing

Physical Parameters Measured: Solar reflected energy of
earth features

Available: One

5.3 Wild Heerbrugg - RC-10

Description: Aerial survey camera

Format Size: 9 inch X 9 inch (23 cm X 23 cm)

Lens: 88 mm (3.46 inch) Super Aviogon II (SAG II) - 3 available; or 6 inch Universal Aviogon II (UAG II) - 5 available

Shutter Speed: 1/100 to 1/1000 second - continuously variable

Cycle Rate: 1 cycle per 1.8 seconds - maximum

Film Supply: Individual feed and take-up cassettes with a separate vacuum platen

Film Capacity: 9 inch X 250 feet black and white estar base - 280 exposures; or 9 inch X 200 feet colour estar base - 225 exposures

Filters:

SAG II - 88 mm

Neutral Sandwich
Neutral AV 3.3
Neutral AV 3.0
420 AV 3.0
500 AV 2.2
500 AV 2.2
520 AV 3.3
525 AV 3.0
545 AV 4.4
700 AV 2.2

UAG II - 6 inch

Neutral AV 2.2
Neutral AV 2.2
Neutral AV 2.2
420 AV 2.0
420 AV 2.0
525 AV 2.0
525 AV 2.0
525 AV 2.0
300-400 nm uv
705 AV 2.0

To the above filters can be added CC (gelatin) filters in a special holder between the lens and the focal plane.

Physical Parameters Measured: Solar reflected energy of earth features

Available: 5 - cameras, 3 - 88 mm lens cones, 5 - 6 inch lens cones

5.4 Hasselblad 500EL 70mm

Format Size: 2.25 inches square

Lens: 40 mm f4 or 80 mm f2.8

Shutter Speed: 1 - 1/500 second

Cycle Rate: Manual or controlled by external intervalometer

Film Supply: Motor driven magazine

Film Capacity: 70 mm x 150 feet black and white estar base
- 700 exposures; or 70 mm x 100 feet colour estar base
- 460 exposures

Spectral Characteristics: Dependent on film filter combination used

Filters: Most commercially available glass and/or gelatin filters including HF and CC series.

Spatial Characteristics: 20 lines per mm nominal

Physical Parameters Measured: Solar reflected energy of earth features

Available: 3 camera bodies, 3 magazines, 4 - 80 mm lenses,

5.5 Barnes PRT-5

Description: Precision Radiation Thermometer

Spectral Characteristics: 8-14 um or 9.5-11.5 um

Spatial Characteristics: 2 degree field of view

Temperature Range: -20 degrees C to +75 degrees C in three ranges

Absolute Accuracy: Plus or minus 0.1 degree C

Sensitivity: 0.1 degree C

Data Output: Equivalent black body radiation temperature for recording on chart paper or magnetic tape

Physical Parameters Measured: Infrared radiation emitted from the Earth's surface

Available: 8-14 um - each two, 9.5-11.5 um - each two

5.6 Barnes PRT-6

Description: Precision Radiation Thermometer

Spectral Characteristics: 3.4-4.2 um or 9.5-11.5 um
Spatial Characteristics: 2 degree field of view
Absolute Accuracy and Sensitivity: Dependent on filters used

Data Output: Target radiance. May also be calibrated in terms of equivalent black body radiation temperature. May be recorded on a chart recorder.

Physical Parameters Measured: Infrared radiation emitted from the Earth's surface

Available: One

5.7 8-14 um Versus 9.5-11.5 um

The wider the spectral pass-band of a radiometer, the greater is the incoming radiation flux. Hence, the higher is its sensitivity and the smaller is the noise associated with the measurement.

If the radiometer's pass-band covers an attenuation band of the atmosphere, and a target is "viewed" through a significant thickness of this atmosphere, then the measurement will differ considerably from what it would be were the radiometer close to the target. First, the atmosphere attenuates the radiation emitted by the target so that a smaller quantity reaches the radiometer. Second, the intervening atmosphere emits radiation in proportion to its degree of attenuation. This emission will be seen by the radiometer. If the intervening atmosphere is at the same temperature as the target radiation temperature, then no error will result. The amount of attenuation will be exactly balanced by the atmospheric emission. The

atmospheric emission is, however, temperature dependent. Atmosphere hotter than the target will emit more radiation than it absorbs from the target; the radiometer will indicate an apparent target temperature higher than the real temperature. Conversely (as is more usual), a colder atmosphere will emit less radiation than it absorbs from the target; the radiometer will indicate an apparent target temperature lower than the real temperature.

The temperature error depends on a number of factors:

1. The temperature difference between atmosphere and target.
2. The attenuation factor of the atmosphere in the radiometer pass-band.
3. The path length over which the measurement is made.
4. The density of absorbing gases in the atmosphere. (e.g. water vapour, carbon dioxide, etc.)

Water vapour is the critical offender. The greatest error will occur on a humid day.

The radiometer pass-band is dictated by its filter. The 9.5-11.5 μm band is the most transparent part of the thermal IR. The 8-14 μm band is less transparent; water vapour absorption occurs between 8 and 9.5 μm and between 11.5 and 14 μm .

With measurements made through intervening atmosphere, a 9.5-11.5 μm radiometer will give an error of about one-third that of a 8-14 μm radiometer. The reduction of the pass-band from 8-14 μm to 9.5-11.5 μm results in slightly poorer sensitivity and slightly more noise, but these are usually "good" enough that it is of no issue to

most applications.

The radiometer with 9.5-11,5 um pass-band is to be preferred over the 8-14 um one, and is the one normally employed for airborne work.

5.8 Daedalus (single channel)

Description: A single-channel optical mechanical line scan radiometer that records energy reflected or emitted from the Earth's surface.

Internal Design Features:

Field of view 77 degrees 20 minutes, gyro stabilized
(roll) to plus or minus 5 degrees
Mirror speed - 60 scans per second
2 calibrated black bodies

Detector (A) - cooled mercury cadmium telluride
Detector (B) - cooled indium antimonide

Spatial Resolution:

Detector (A) - 2.5 milliradians
Detector (B) - 1.7 milliradians

Spectral Bandwidth

(A) - 8-14 um (cut on filter at 8.5 um)
(B) - 3-5 um (cut on filter at 4.5 um)

Data Output: Magnetic tape

Physical Parameters Measured: Infrared radiation emitted
from the Earth's surface

Available: One

5.9 Daedalus (dual-channel)

Description: A dual channel optical mechanical line scanning radiometer that records energy reflected or emitted from the Earth's surface

Internal Design Features:

Field of view 77 degrees 20 minutes, gyro stabilized (roll) to plus or minus 5 degrees
Mirror speed - 60 scans per second
2 calibration black bodies

Detector (A) - cooled mercury cadmium telluride
Detector (B) - cooled indium antimonide

Spatial Resolution: 2.5 milliradians

Spectral Bandwidth:

(A) - 8-14 um
(B) - 3.5-5.5 um (cut on filter at 4.5 um)

Data Output: Magnetic tape - capable of two channel simultaneous operation

Physical Parameters Measured: Infrared radiation emitted from the Earth's surface

Available: One

NOTE

CCRS utilizes a field printer to produce negatives on film from magnetic tape. One copy is sent directly to the user and one copy is indexed, annotated and stored by NAPL. (Effective July 1975, storage of one copy in NAPL will be

discontinued.) Original tapes are stored within the Data Acquisition Division and will be reproduced on request.

A signal processor is now available to provide users with a "density slicing" service if required. (See Section 5.10)

5.10 Daedalus Imagery Processing

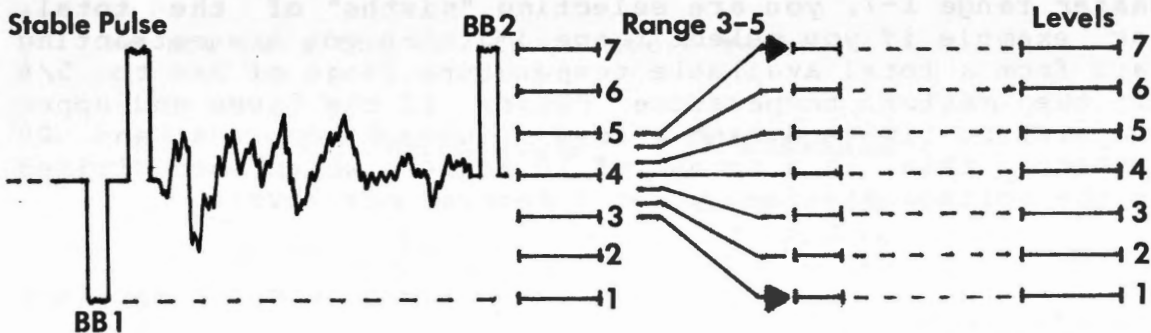

Figure 6 - Daedalus Level Slicing

Daedalus infrared imagery can be processed in two basic modes: relative and quantitative. The relative mode of processing produces a continuous tone image of the ground. The relative tones on the film represent relative temperatures on the ground. Absolute temperatures cannot be determined by this method of processing.

The quantitative mode employs a set of voltage dividers which slice the total signal range into six even levels of information. This total level slicing of all six even

levels is called a "Master Set" or "Range 1-7" (six levels). Besides the full range of 1-7, it is possible to select the following alternate ranges:

					6-7
				5-6	5-7
			4-5	4-6	4-7
		3-4	3-5	3-6	3-7
	2-3	2-4	2-5	2-6	2-7
1-2	1-3	1-4	1-5	1-6	1-7

The first number must be less than the second number.

When you select these ranges they slice the signal into six even levels. The thermal black bodies one and two are the lower and upper temperature limits of the master temperature range. When you select a range other than the master range 1-7, you are selecting "sixths" of the total. For example if you select range 3-5 then you are extracting data from a total available temperature range of 3/6 to 5/6 of the master temperature range. If the lower and upper temperature limits during recording were 2 degrees and 20 degrees, this is a spread of 18 degrees which when divided by the voltage dividers gives 3 degrees per level.

In the master set this gives seven distinct temperatures:

<u>Range</u>	<u>Temperature</u>
7	20 degrees
6	17 degrees
5	14 degrees
4	11 degrees
3	8 degrees
2	5 degrees
1	2 degrees

These seven temperatures define the six levels:

<u>Level</u>	<u>Temperature Range</u>
6	17-20 degrees
5	14-17 degrees
4	11-14 degrees
3	8-11 degrees
2	5-8 degrees
1	2-5 degrees

If you now select range 3-5, you use 3/6 of the total or 8 degrees, to 5/6 of the total or 14 degrees. This establishes the new lower and upper limits of 8 degrees and 14 degrees. These new limits will now be sliced by the voltage dividers.

$$14 - 8 = 6 \text{ (Temperature Range)}$$

$$6 \text{ degrees} / 6 \text{ levels} = 1 \text{ degree per level}$$

We now have the new temperature range:

<u>New Range (3-5)</u>	<u>Temperature</u>
7	14 degrees
6	13 degrees
5	12 degrees
4	11 degrees
3	10 degrees
2	9 degrees
1	8 degrees

This new temperature range defines six new levels:

<u>Level</u>	<u>Temperature Range</u>
6	13-14 degrees
5	12-13 degrees
4	11-12 degrees
3	10-11 degrees
2	9-10 degrees
1	8-9 degrees

In summary, any range we wish can be selected and it will be divided into six levels. To determine just what temperature we are observing we must go through the mathematical process and attain the six levels of the master set and then the six levels for the selected range.

On the photographic negative each level is represented by a particular shade of grey. This particular density will correspond to that temperature range throughout the flight run. For convenience, prior to each flight run an electronic step wedge which prints out the six different density levels (shades of grey) will be put on the film. The user will note that these wedges also include two other steps - black and white. These represent the black bodies or, if you wish, the limits of the signal structure. Everything that is below (outside) black body one is white and everything that is above (outside) black body two is blacked out. On the original negative, the greater the temperature of the ground, the greater the density of the film. The six temperature levels, when processed individually, are called isolevels. An isolevel prints one of the shades of grey (density levels) at a time. It can print 1/6 of the total range you have selected. Since it is printed one level at a time, there is no need for it to be a particular density to distinguish it from other densities. Therefore it is printed on the film as black on the transparent background.

In addition to quantitative imagery slicing the Daedalus field printer offers the following additional features:

1. Bi-format imagery on five inch wide film (Two 70 mm side by side strips)
2. Five inch single format imagery
3. 70 mm single format imagery
4. Two channel imagery ratioing in various modes

3.11 (Providing two channels have been recorded simultaneously)

5. Imagery linear rectification

6. Nadir line and PRT-5 trace overlays

1. Digitization of the Oesdalus tape obtained from the aircraft flight is made on a computer compatible tape (CCT). This CCT is retained for a period of one week following the acquisition for repeat runs with different flight parameters for the film product should the user require same.

2. Generation of a control tape for the Continuous Strip Film Recorder (CSFR).

8-LEVEL QUANTITATIVE TEMPERATURES

BB1 = -4.00 BB2 = 10.00 DIFF = 14.00

RANGE	1-7	1-6	1-5	1-4	1-3	1-2
7	10.00	7.67	5.33	3.00	0.67	-1.67
6	7.67	5.72	3.78	1.83	-0.11	-2.06
5	5.33	3.78	2.22	0.67	-0.89	-2.44
4	3.00	1.83	0.67	-0.50	-1.67	-2.83
3	0.67	-0.11	-0.89	-1.67	-2.44	-3.22
2	-1.67	-2.06	-2.44	-2.83	-3.22	-3.61
1	-4.00	-4.00	-4.00	-4.00	-4.00	-4.00

RANGE	2-7	2-6	2-5	2-4	2-3
7	10.00	7.67	5.33	3.00	0.67
6	8.06	6.11	4.17	2.22	0.28
5	6.11	4.56	3.00	1.44	-0.11
4	4.17	3.00	1.83	0.67	-0.50
3	2.22	1.44	0.67	-0.11	-0.89
2	0.28	-0.11	-0.50	-0.89	-1.28
1	-1.67	-1.67	-1.67	-1.67	-1.67

RANGE	3-7	3-6	3-5	3-4
7	10.00	7.67	5.33	3.00
6	8.44	6.50	4.56	2.61
5	6.89	5.33	3.78	2.22
4	5.33	4.17	3.00	1.83
3	3.78	3.00	2.22	1.44
2	2.22	1.83	1.44	1.06
1	0.67	0.67	0.67	0.67

RANGE	4-7	4-6	4-5
7	10.00	7.67	5.33
6	8.83	6.89	4.94
5	7.67	6.11	4.56
4	6.50	5.33	4.17
3	5.33	4.56	3.78
2	4.17	3.78	3.39
1	3.00	3.00	3.00

RANGE	5-7	5-6
7	10.00	7.67
6	9.22	7.28
5	8.44	6.89
4	7.67	6.50
3	6.89	6.11
2	6.11	5.72
1	5.33	5.33

RANGE	6-7
7	10.00
6	9.61
5	9.22
4	8.83
3	8.44
2	8.06
1	7.67

Figure 7 -- Scanner Temperature Printout

5.11 Temperature Coded Colour Daedalus Imagery

A popular output product available for the Daedalus infrared scanner is a colour image in which the Daedalus readings have been converted to temperature, a colour code assigned to particular temperature ranges, and the whole printed on a 9.5 inch wide continuous strip colour film. At present this is achieved in two steps but in late 1977 it will be possible to generate the film in a single step. The two steps at present are:

1. Digitization of the Daedalus tape obtained from the aircraft flight to produce a computer compatible tape (CCT). This CCT is retained for a period of one week following its generation for repeat runs with different output parameters for the film product should the user require same.
2. Generation of a control tape for the Continuous Strip Film Recorder (CFSR).

During Daedalus flights infrared sensed data of the ground is generated along with calibration data obtained from two black bodies maintained at a constant known temperature. This calibration information is used to convert the Daedalus infrared sensed intensity information to temperature.

The "standard" option is that in which the temperature range between the cold and hot black bodies is divided into ten approximately equal intervals and a standard colour (following the spectrum in which purples are considered cold and reds and browns hot) is assigned to each interval. Values below the cold black body are coded to white and above the hot black body are coded to black.

The image, with its ten colours, plus black and white, is corrected for S-bend and also for orthogonality (from a knowledge of the altitude and velocity of the aircraft). Output is on a continuous strip film 9.5 inches wide (of

which approximately 8.5 inches is used for the image). Theoretically the length of the film is up to 250 ft. but strips are usually limited to about 8500 scan lines. The "standard" option includes a variable, user assigned annotation, plus annotation indicating all the parameters used for the output. The annotated colours used are also output, as is the colour histogram, and a black and white histogram of the data. The colour histogram prints out the colours used in the image, proportional to the main colour in the image, which is taken as 100. The black and white histogram is a representation of the individual temperatures used in the image. A computer printout of the parameters used, the colour assignments, and the black and white histogram, is also available in the "standard" option.

Present price for the "standard" option is:

Cost of Project = Distance(Ft.)/Altitude(Ft.) X \$12.00

Additional options presently available at the same price (although this may change in the future) are:

1. Standard colour sets of 5, 6, 12, 15, 20 plus black and white.
2. Standard ranges (temperature breaks) between arbitrarily assigned minimum and maximum temperatures 5, 10, 15, and 20.
3. Individually assigned colour codes (from a master set of 792).
4. Individually assigned temperature ranges with different parameters.

Reproduction may be ordered from the master colour negative at a cost of \$1.25 per foot of imagery(min. charge

- 25 ft.)

Repeat runs (if the CCT is still available -- one month time limit) can also be made.

Inquiries about the program and requests for imagery should be directed to:

Canada Centre for Remote Sensing
2464 Sheffield Road
Ottawa, Ontario
K1A 0Y7
Attn: Airborne Operations Section

Telephone: 993-0121 (Sheffield Road)
998-3101 (Operations Hangar)
Telex: 053-3777 (Sheffield Road)

5.12 Tektronix J16 Photometer

Description: Digital photometer/radiometer

Spectral Characteristics: With J6502 "Irradiance Probe", provides linear sensitivity (100%) from 450 nm to 1000 nm. The probe is filtered to correspond to the wavelengths to which various film and filter combinations are sensitive.

Spatial Characteristics: Approximately 20 degree angle of view, mounted to view the terrain covered by the cameras

Sensitivity: .001-1000 watts per square centimeter

Data: Primarily provides a measure of reflected energy that is used as a guide for film exposure determination while airborne. It is perhaps most useful in cases that require critical exposure of a specific portion of the terrain to be photographed, dictated by the specific interests of the Principal Investigator.

Available: Two per aircraft

5.13 Exotech ERTS Radiometer

Description: Radiometer spatially and spectrally matched to ERTS bands. Suitable for ERTS ground truth data and Vinten multispectral camera pack exposure determination

Spectral Characteristics: Four channels/bands. 500-600 nm, 600-700 nm, 700-800 nm, 800-1100 nm.

Spatial Characteristics: Can be hand-held or mounted in the aircraft. Facility for 15 degree circular field of view, 1 degree square field of view for ERTS format, or

2 PI steradian field of view for incident radiation

Sensitivity: .0001 - .01 watts per square centimeter
through four levels of gain.

Accuracy: Plus or minus five percent

Data Output: Manual or magnetic tape recording (on board
aircraft only) of all four bands individually and
simultaneously, or each band one-at-a-time

Available: One

6.0 FILM

6.1 General

Every attempt is made to purchase photographic film once per year in large orders. Purchase instructions require that all rolls of each film type have the same emulsion number. Film rolls are stored in walk-in freezers at the manufacturer's recommended temperature. Small freezers are utilized for the storage of small quantities of film in the camera loading area.

The following pages list the film types and sizes available at all times within the airborne remote sensing system. Spectral sensitivity and spectral dye density curves are reproduced with permission from a copyrighted Kodak publication.

6.2 Kodak Plus-X Aerographic Film 2402 (Estar Base)

70 mm X 150 feet - Vinten -- \$25.86 per roll

9.5 inch X 250 feet - RC-8, RC-10 -- \$129.91 per roll

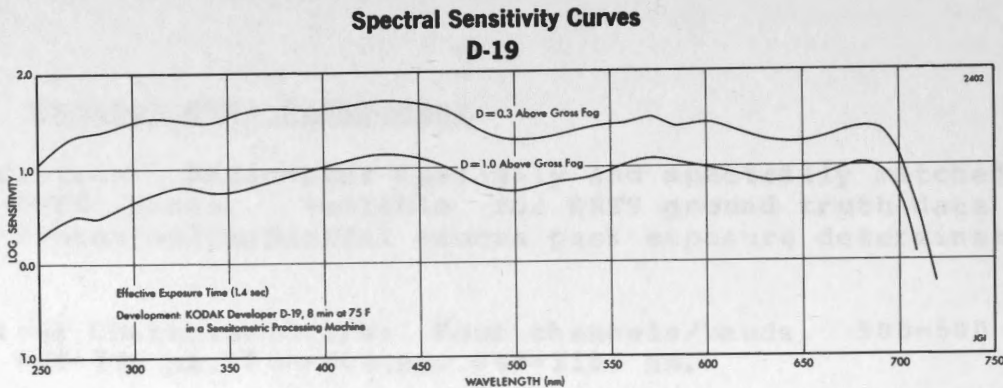

Figure 8 -- 2402 Spectral Sensitivity

This is a general purpose black and white film used

when relatively high resolution reproduction is required. Its extended red sensitivity permits use in the multispectral camera system for recording in the green and red spectral bands.

6.3 Kodak Double-X Aerographic Film 2405 (Estar base)

70 mm X 150 feet - Vinten -- \$26.93 per roll

9.5 inch X 250 feet - RC-8, RC-10 -- \$136.89 per roll

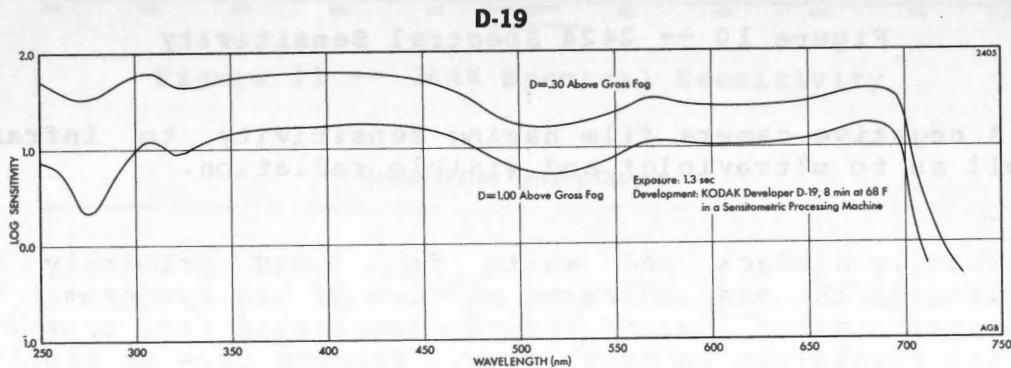

Figure 9 -- 2405 Spectral Sensitivity

This is a general purpose black and white film used when lower than normal light conditions are likely to be encountered. Its extended red sensitivity permits use in the multispectral camera systems for recording in the green and red spectral bands.

Because the spectral response of 2402 and 2405 are virtually identical, these two film types are used interchangeably at the discretion of the sensor operator.

6.4 Kodak Infrared Aerographic Film 2424 (Estar Base)

70 mm X 150 feet - Vinten -- \$47.60 per roll

9.5 inch X 250 feet - RC-8, RC-10 -- \$254.63 per roll

Spectral Sensitivity Curves

D-19

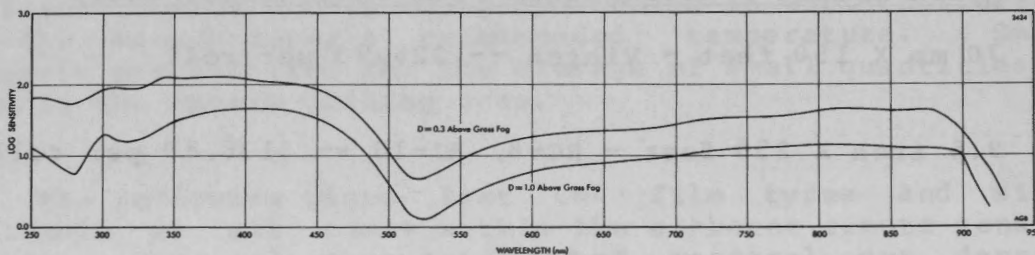

Figure 10 -- 2424 Spectral Sensitivity

A negative camera film having sensitivity to infrared as well as to ultraviolet and visible radiation.

This is a black and white film used primarily for recording in the near infrared portion of the spectrum. Its speed approximates that of Plus-X aerographic film type 2402 but its resolution is much lower. Extreme care in handling is required to prevent the formation of light and chemical fog.

6.5 Kodak MS Ektachrome Aerographic Film 2448 (Estar Base)

70 mm X 100 feet - Vinten -- \$65.73 per roll

9.5 inch X 200 feet - RC-8, RC-10 -- \$417.70 per roll

A fine grain, medium speed camera colour reversal aerial film.

Spectral Sensitivity Curves

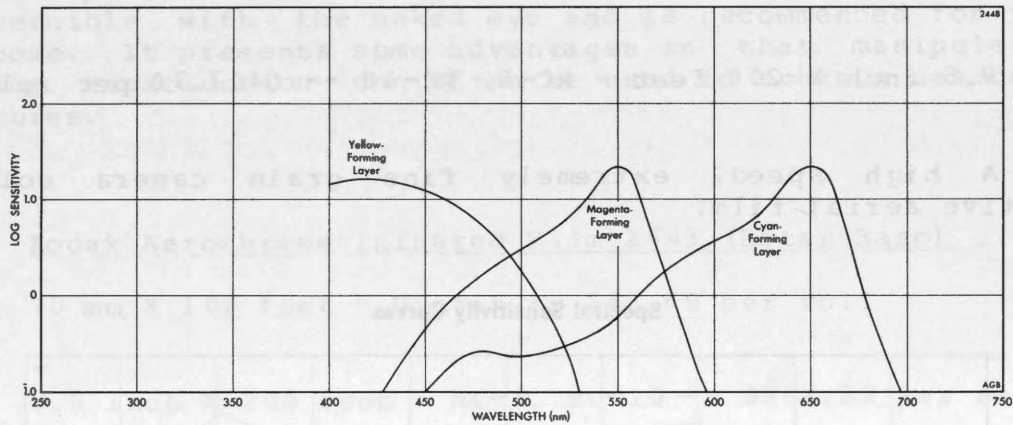

Figure 11 -- 2448 Spectral Sensitivity

Spectral Dye Density Curves

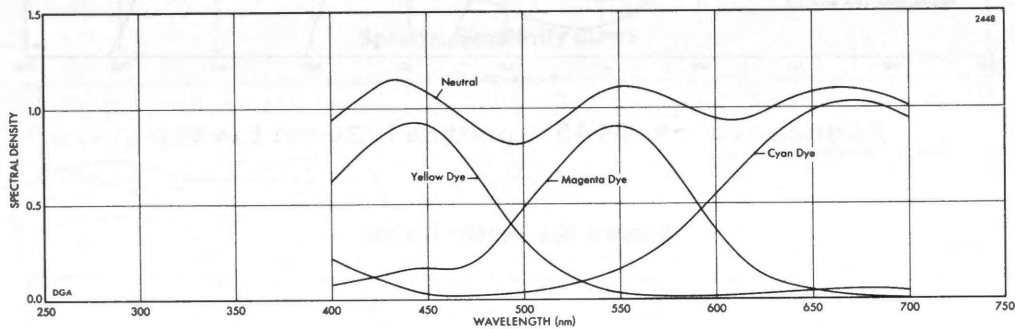

Figure 12 -- 2448 Spectral Dye Density

This is a general purpose positive colour film used when immediate access to a positive original image is desirable. It has been successfully used in the recording of vegetation, geological features and underwater formations including aquatic plants.

6.6 Kodak Aerocolor Negative Film 2445 (Estar Base)

70 mm X 100 feet - Vinten -- \$65.73 per roll

9.5 inch X 200 feet - RC-8, RC-10 -- \$417.70 per roll

A high speed, extremely fine grain camera colour negative aerial film.

Spectral Sensitivity Curves

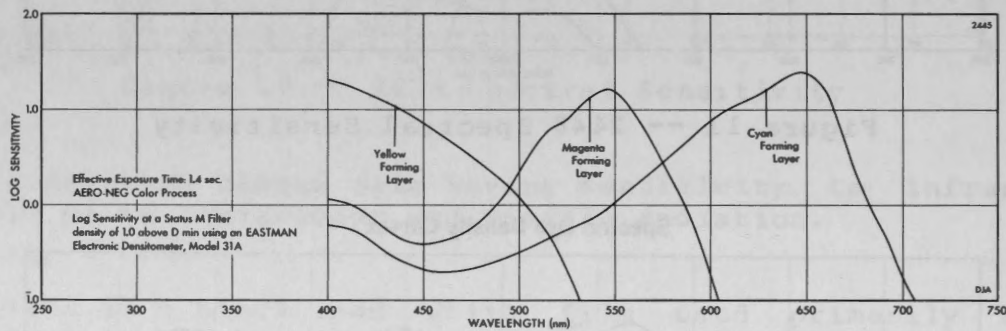

Figure 13 -- 2445 Spectral Sensitivity

Spectral Dye Density Curves

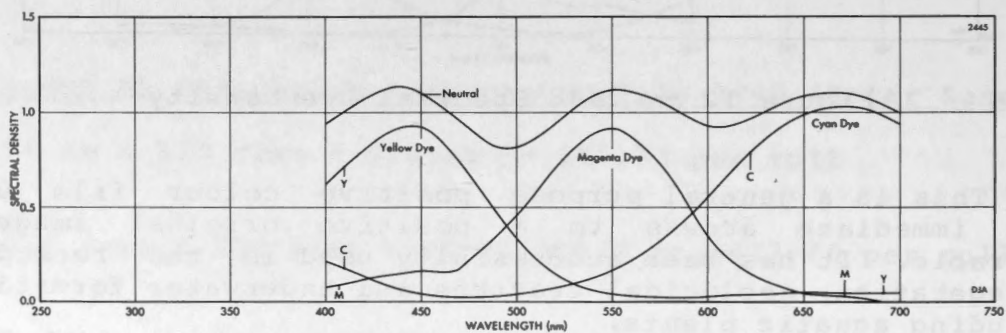

Figure 14 -- 2445 Spectral Dye Density

A general purpose negative colour film that permits rapid production of positive copies. It has been used

successfully in the recording of vegetation, geological features and underwater formations including aquatic plants. It will penetrate water to a depth equivalent to that discernible with the naked eye and is recommended for this purpose. It presents some advantages in that manipulation during reproduction can often be used to enhance desirable features.

6.7 Kodak Aerochrome Infrared Film 2443 (Estar Base)

70 mm X 100 feet - Vinten -- \$83.80 per roll

9.5 inch X 200 feet - RC-8, RC-10 -- \$554.33 per roll

A false colour reversal film for application where infrared discrimination is required.

Spectral Sensitivity Curve

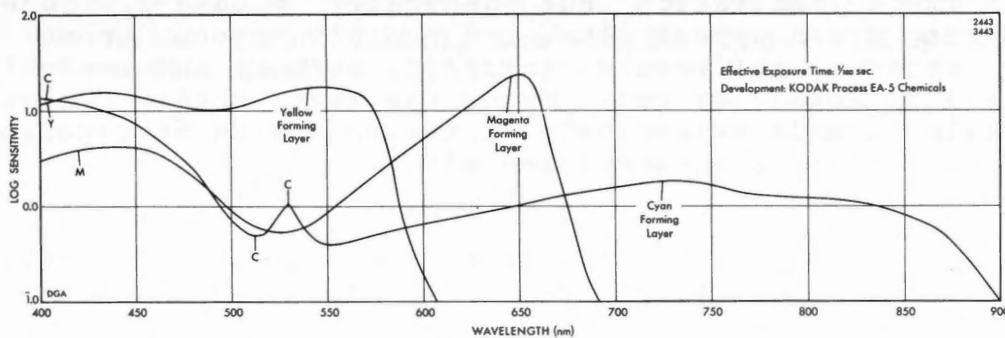

Figure 15 -- 2443 Spectral Sensitivity

Spectral Dye Density Curves

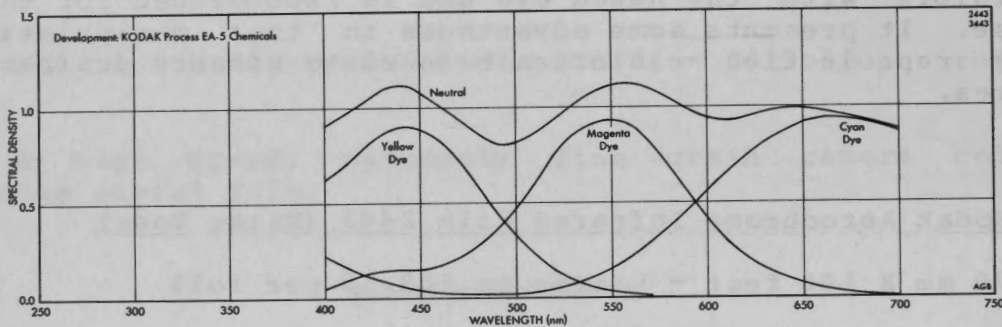

Figure 16 -- 2443 Spectral Dye Density

The three layers of this film are sensitive to green, red and infrared radiation instead of the usual blue, green and red used for normal rendition of the visible spectrum. This can readily be seen by comparing the spectral sensitivity curves with those of type 2448 film. Tones vary with image saturation but generally speaking, objects reflecting green appear blue, red objects appear green and those objects reflecting infrared, such as chlorophyll in vegetation, appear as red. Hence the term "False Colour". This film is used extensively in the recording of vegetation cover to discern its extent and vigor.

As water does not permit the penetration of infrared rays, it appears very dark on the image and the interface between land and water is readily discernible. This feature has also been used to advantage in the recording of ice formations. Surface "algae blooms" are readily recorded on this film as pink swirls. Vegetation protruding above the surface of water is enhanced by its reddish-pink colour.

6.8 Special Purpose Films

The following film types are sometimes available in limited quantities for special purpose missions. Before requesting any of these types of film, the Principal

Investigator should check with CCRS Airborne Operations to ensure their availability.

These film types include:

1. Kodak Tri-X Aerographic Film 2403 (estar base)
2. Kodak Water Penetration Film SO-224 (estar base)
3. Kodak High Definition Ektachrome Film SO-356 (estar base)
4. Kodak Fine Grain Infrared Film FE-3215 (estar base)
5. Kodak Multi-Spectral Infrared Film SO-289 (estar base)
6. Kodak High Definition False Color Film SO-127 (estar base)

7.0 FILTERS

7.1 General

Filters available for each camera in the system are listed in Section 5 -- Sensors. Spectral transmission curves contained in this section are derived from data provided by the National Research Council and result from their tests on sample filters supplied by CCRS.

Standard filters for the Vinten 70 mm cameras with black and white film are the matched ERTS band filters. (500-600 nm, 600-700 nm, 700-800 nm or 800-900 nm) Some of these filters rely on the spectral range of the film to provide the upper cut-off. For colour film the clear glass filter possibly with the addition of an HF-3 haze filter is standard. The minus blue (500 nm cut-off) filter is used for false colour infrared film. Wratten or CC colour correcting gelatin filters may be used in addition to or instead of the above glass filters.

All filters for the metric cameras are "edge" filters. Below a certain wavelength little or no light passes through and beyond this wavelength light of all wavelengths passes virtually without loss. The number system used to describe these filters refers to the wavelength at which 50% of the incident light is transmitted. The A.V. or antivignetting factor refers to the coating on the filter used to compensate for the fall off of illumination at the edges of the picture. These filters can also be used in conjunction with gelatin CC colour correcting filters in a special holder between the lens and the focal plane.

For the six inch metric camera with colour negative film, the 420 nm 2.0 AV filter is normally used. When this filter is not available the NAV (neutral antivignetting) 2.2 AV filter is used.

When false colour infrared film is used with this lens, the 525 nm 2.0 AV filter is normally used. It may sometimes be replaced by the 500 nm 2.2 AV or the 540 nm 2.2 AV filter.

For the super-wide (3.47 inch) lens with colour film, the NAV 3.0 AV filter is standard. With false colour infrared film, the 520 nm 3.3 AV or the 525 nm 3.0 AV filter

is used at low altitudes and the 545 nm 4.4 AV filter is used at high altitudes.

Any of these filters may be used with black and white panchromatic film. The 705 nm 2.0 AV filter is most commonly used with black and white infrared film.

Curves for standard gelatin filters available including the CC and HF series may be found in a publication titled "Kodak Filters for Scientific and Technical Uses". This item is available in most photographic stores at an approximate cost of \$2.00 and is recommended to the serious user of remotely sensed data. It contains far more information on filters than could be published in this bulletin. A limited supply of the most widely used of these filters is kept on hand at CCRS Airborne Operations.

7.2 Vinten Clear Glass

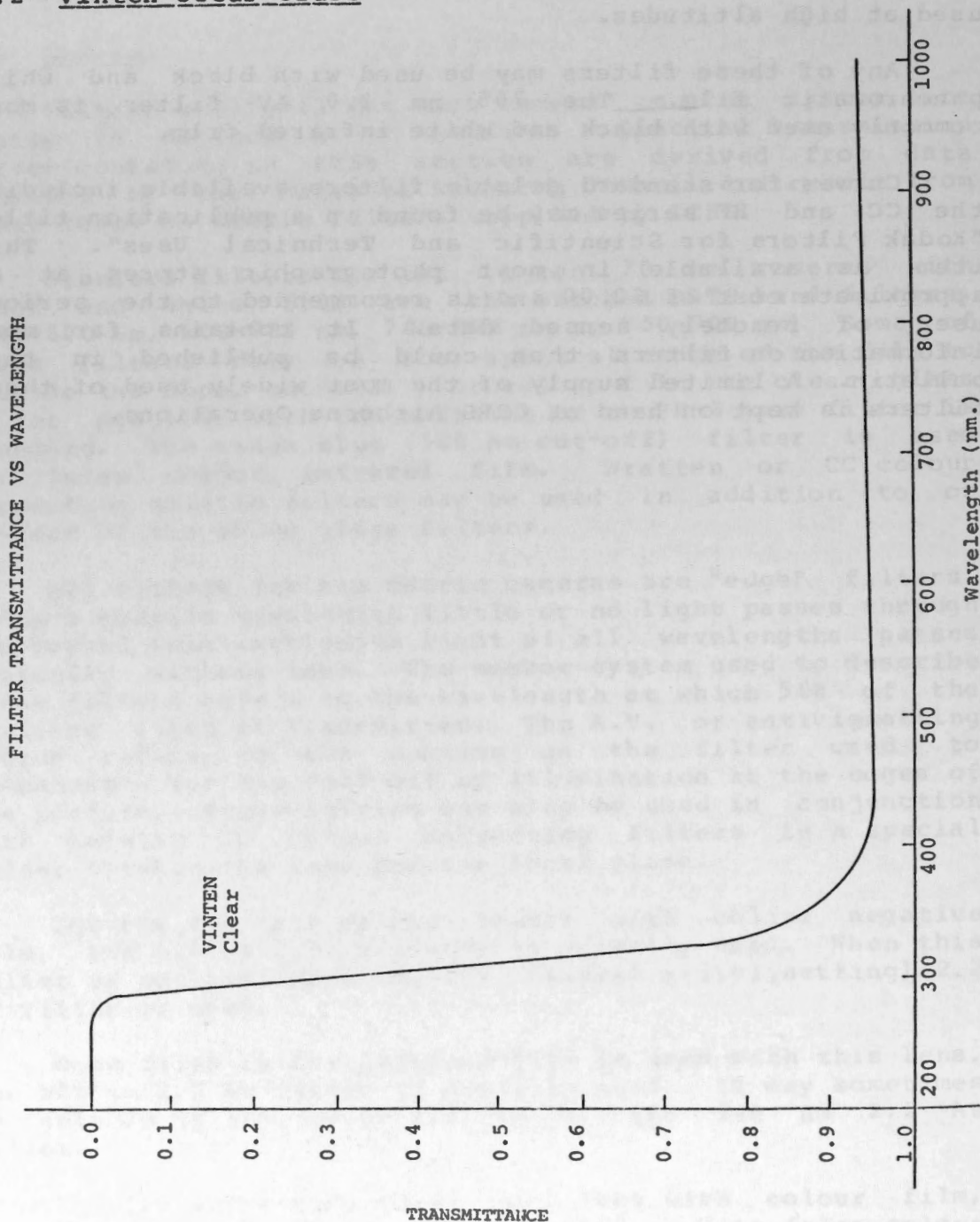

Figure 17 -- Vinten Clear Glass Spectral Transmission

7.3 Vinten Minus Blue Glass

Approximately equivalent to Wratten 12

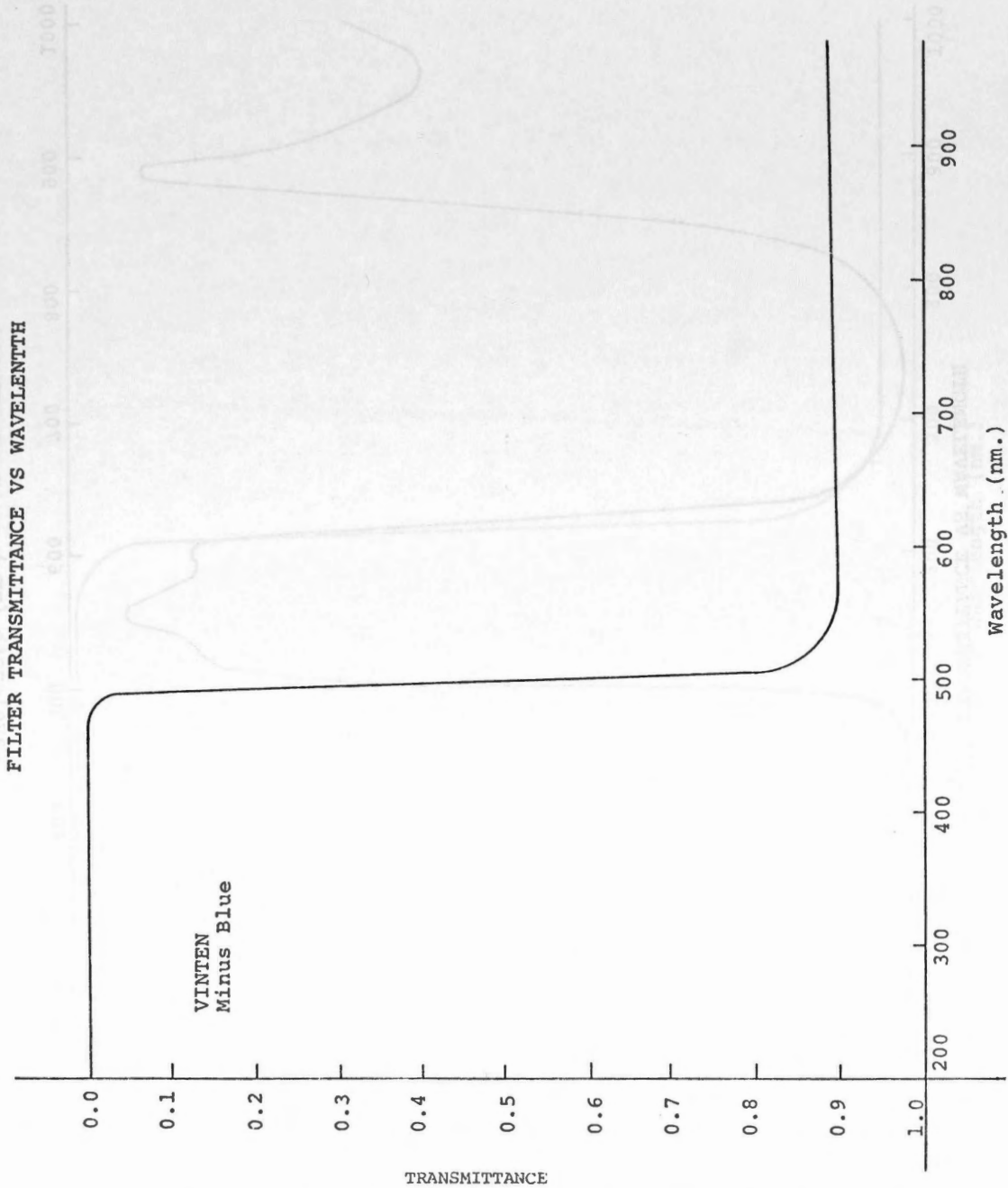

Figure 18 -- Vinten Minus Blue Spectral Transmission

7.4 Vinten 500-600 nm Glass

Approximately equivalent to Wratten 58 or Wratten 12+44

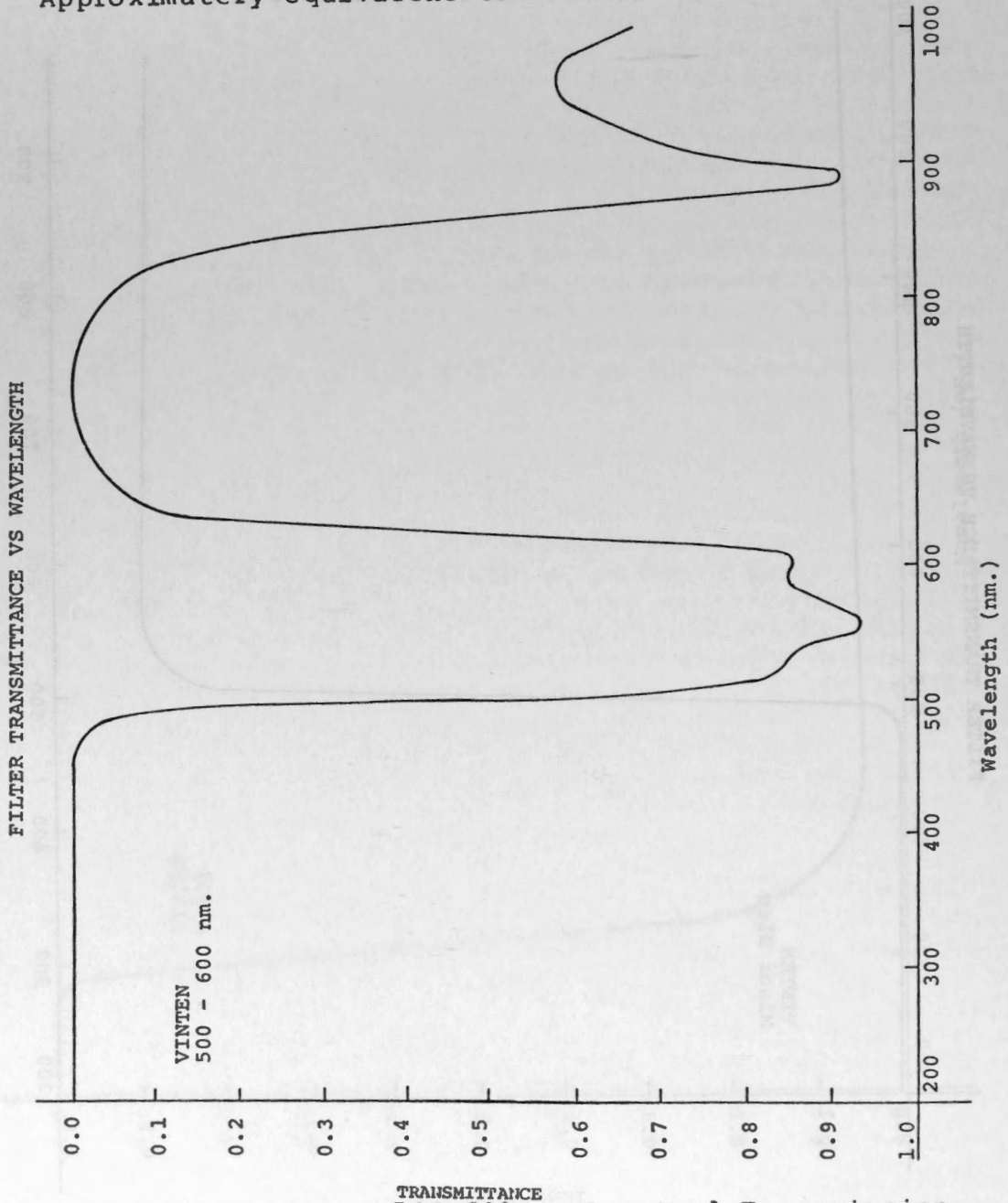

Figure 19 -- Vinten 500-600 nm Spectral Transmission

7.5 Vinten 600-700 nm Glass

Approximately equivalent to Wratten 25

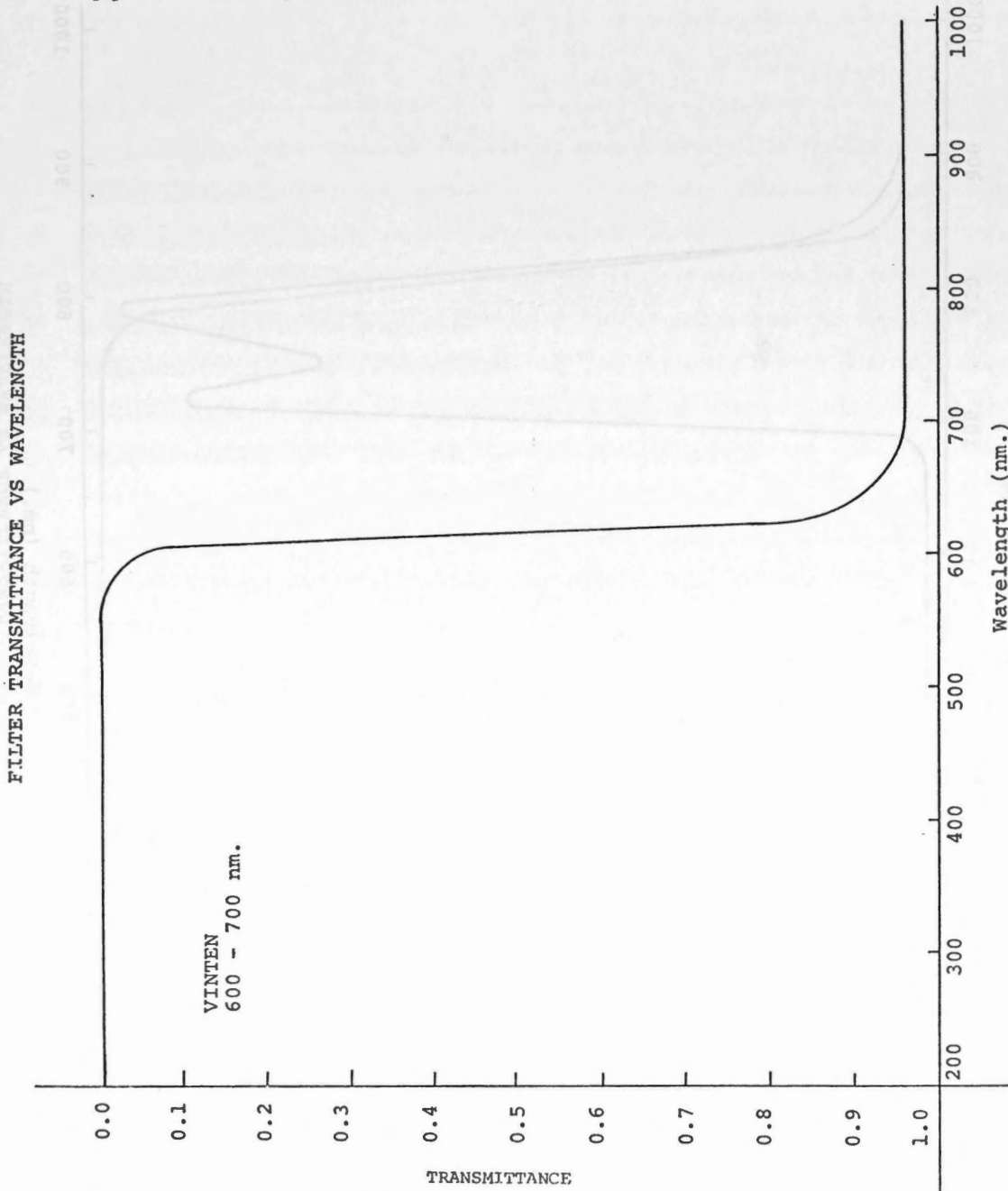

Figure 20 -- Vinten 600-700 nm Spectral Transmission

7.6 Vinten 700-800 nm Glass

Approximately equivalent to Wratten 89B

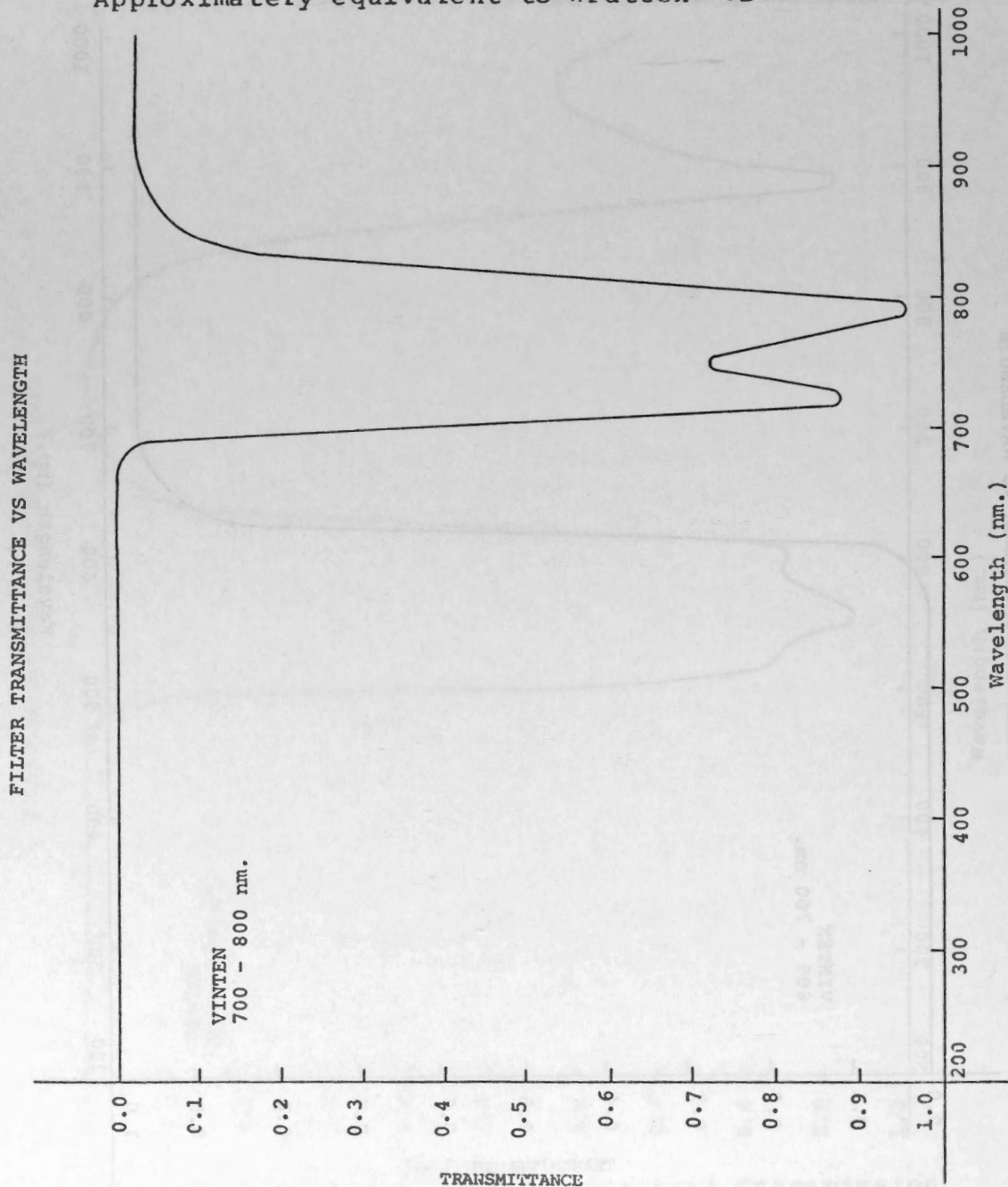

Figure 21 -- Vinten 700-800 nm Spectral Transmission

7.7 Vinten 800-900 nm Glass

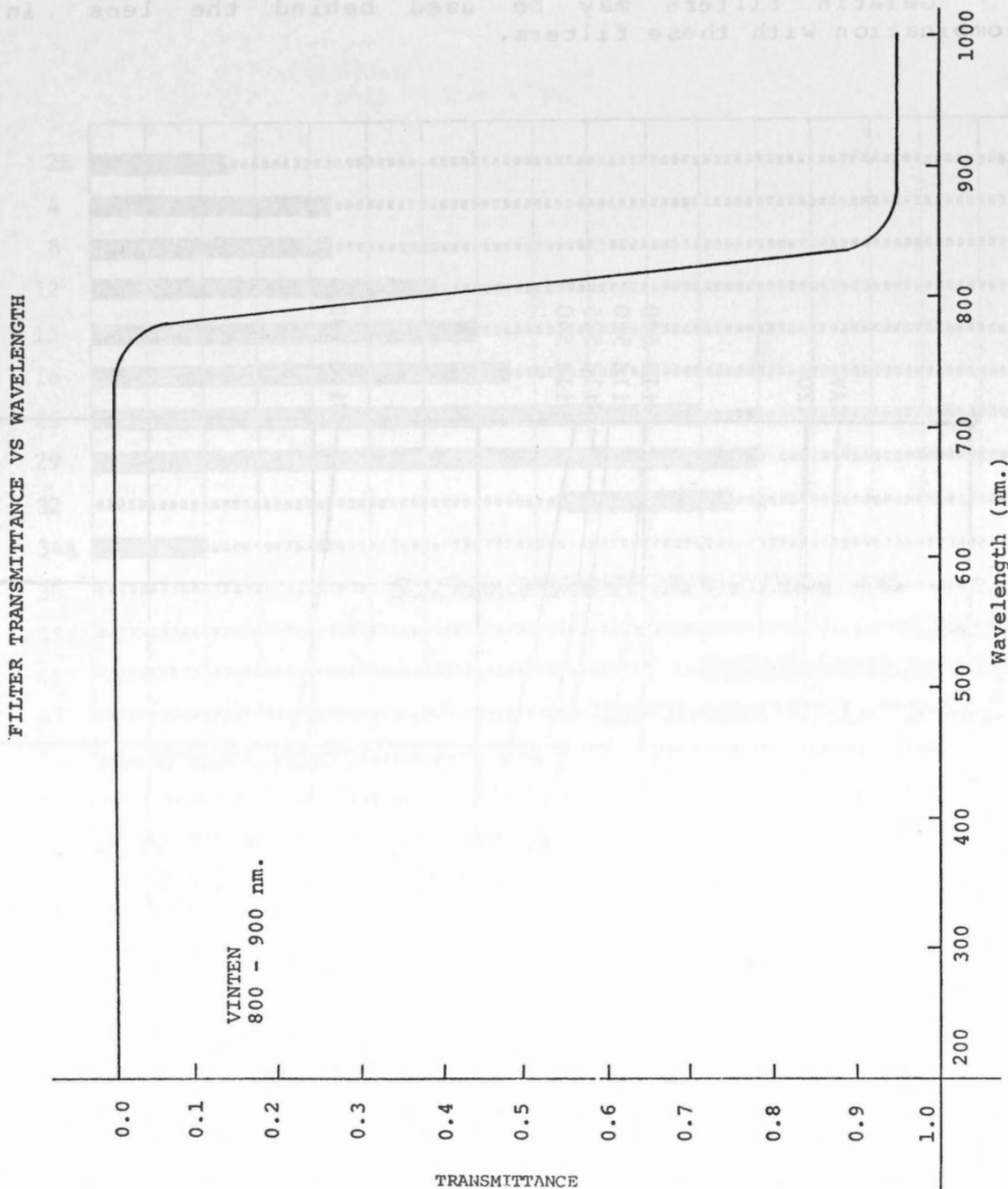

Figure 22 -- Vinten 800-900 nm Spectral Transmission

7.8 Wild Filters

Gelatin filters may be used behind the lens in combination with these filters.

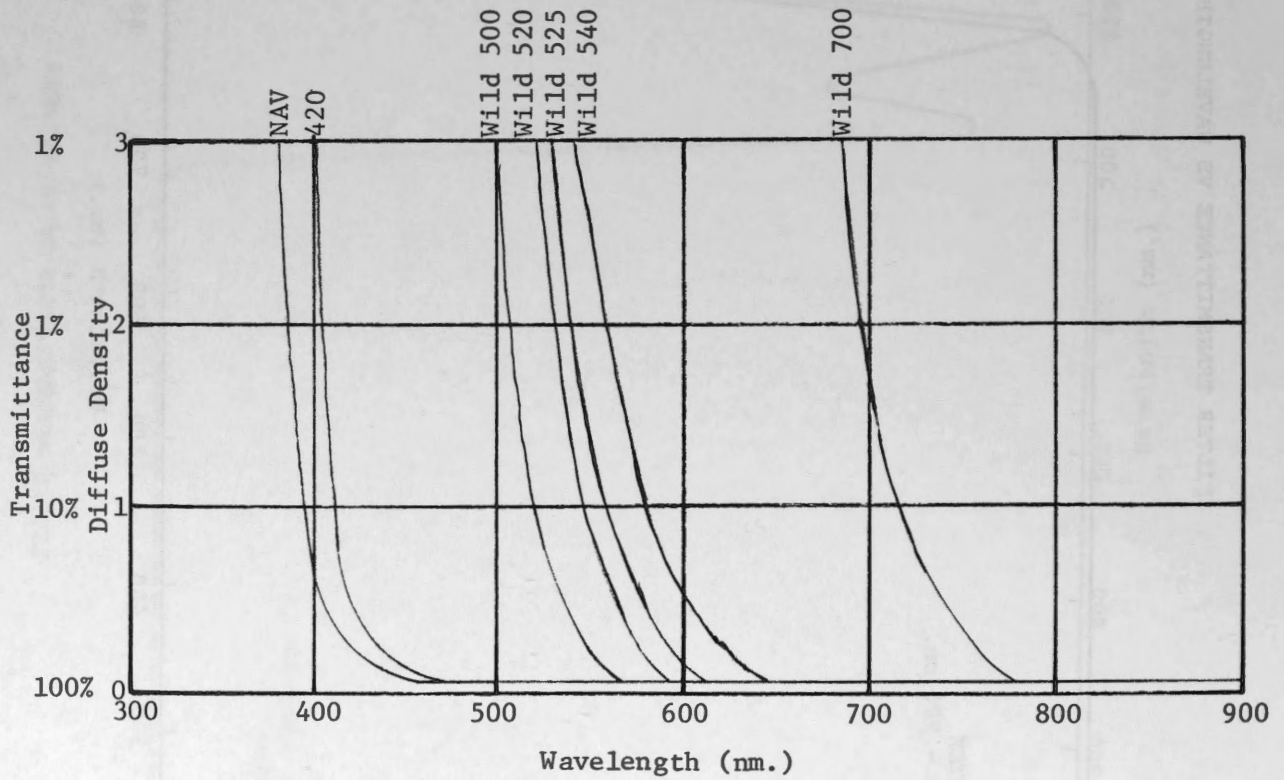

Figure 23 -- Wild Filters

7.9 Kodak Gelatin Filters

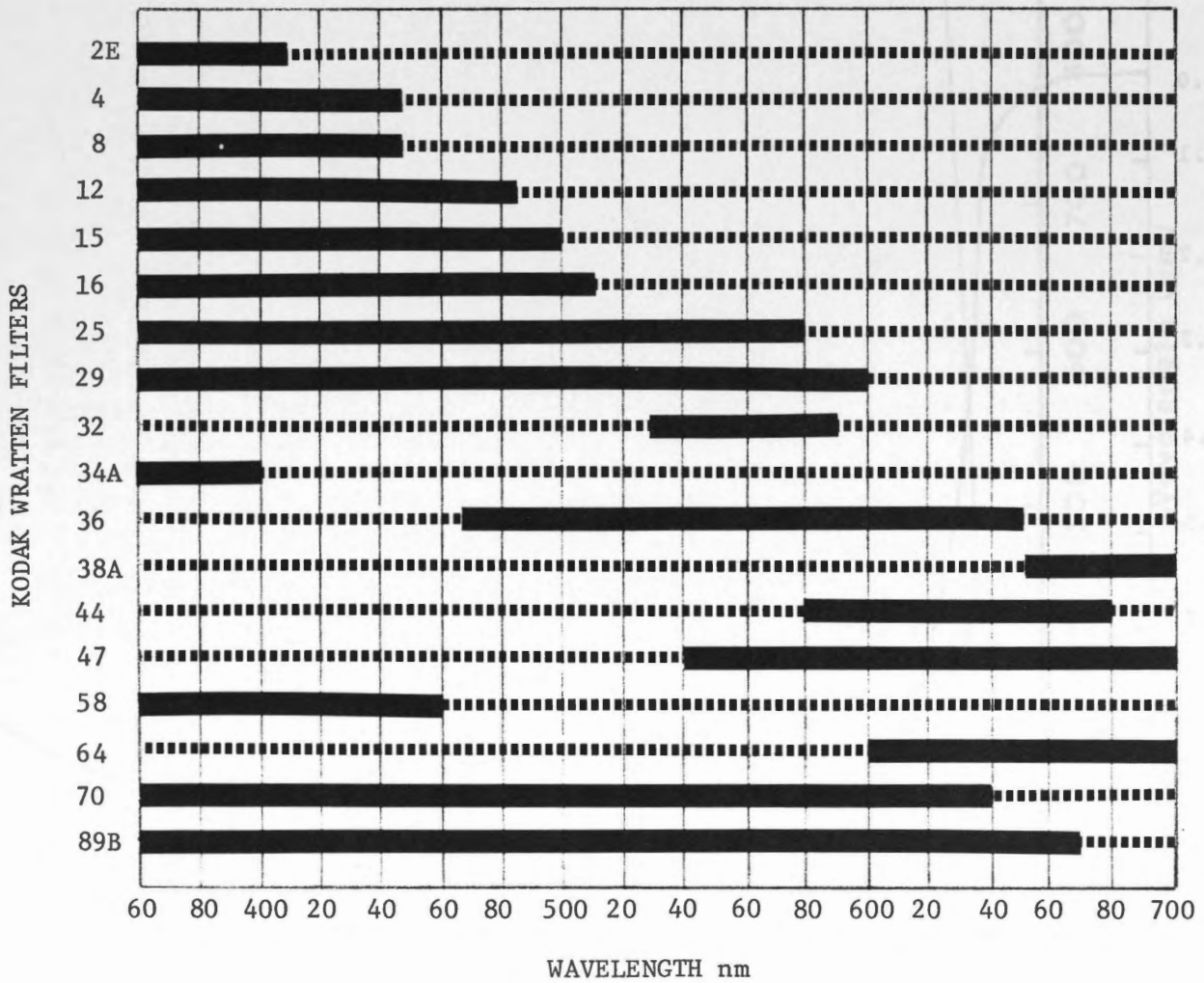

Figure 24 -- Kodak Gelatin Filters

7.10 Transmittance - Aircraft Camera Hatch - DC-3

TRANSMITTANCE VS WAVELENGTH
CAMERA HATCH GLASS

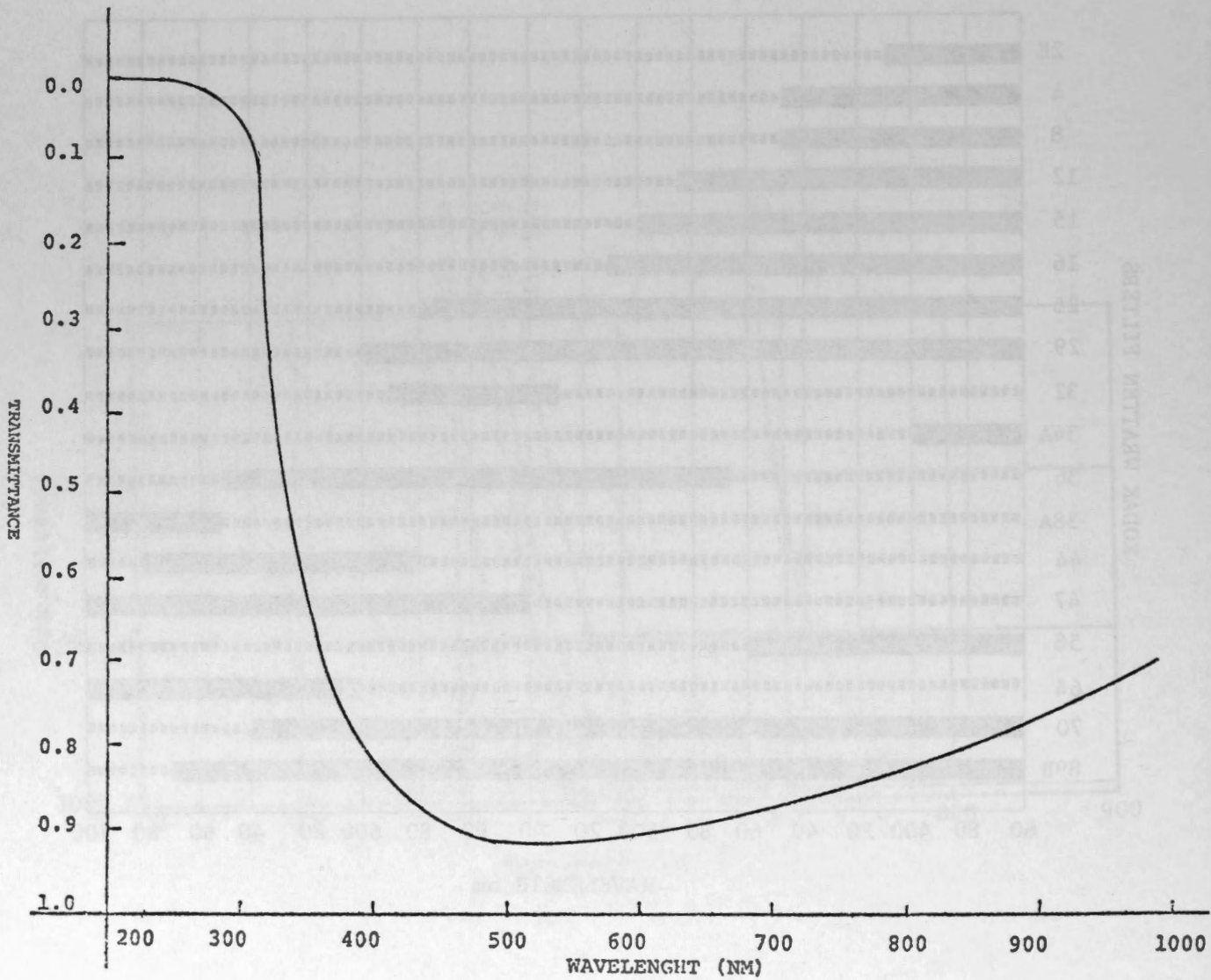

Figure 25 -- DC-3 Camera Hatch Spectral Transmission

7.11 Transmittance - Aircraft Camera Hatch - Falcon

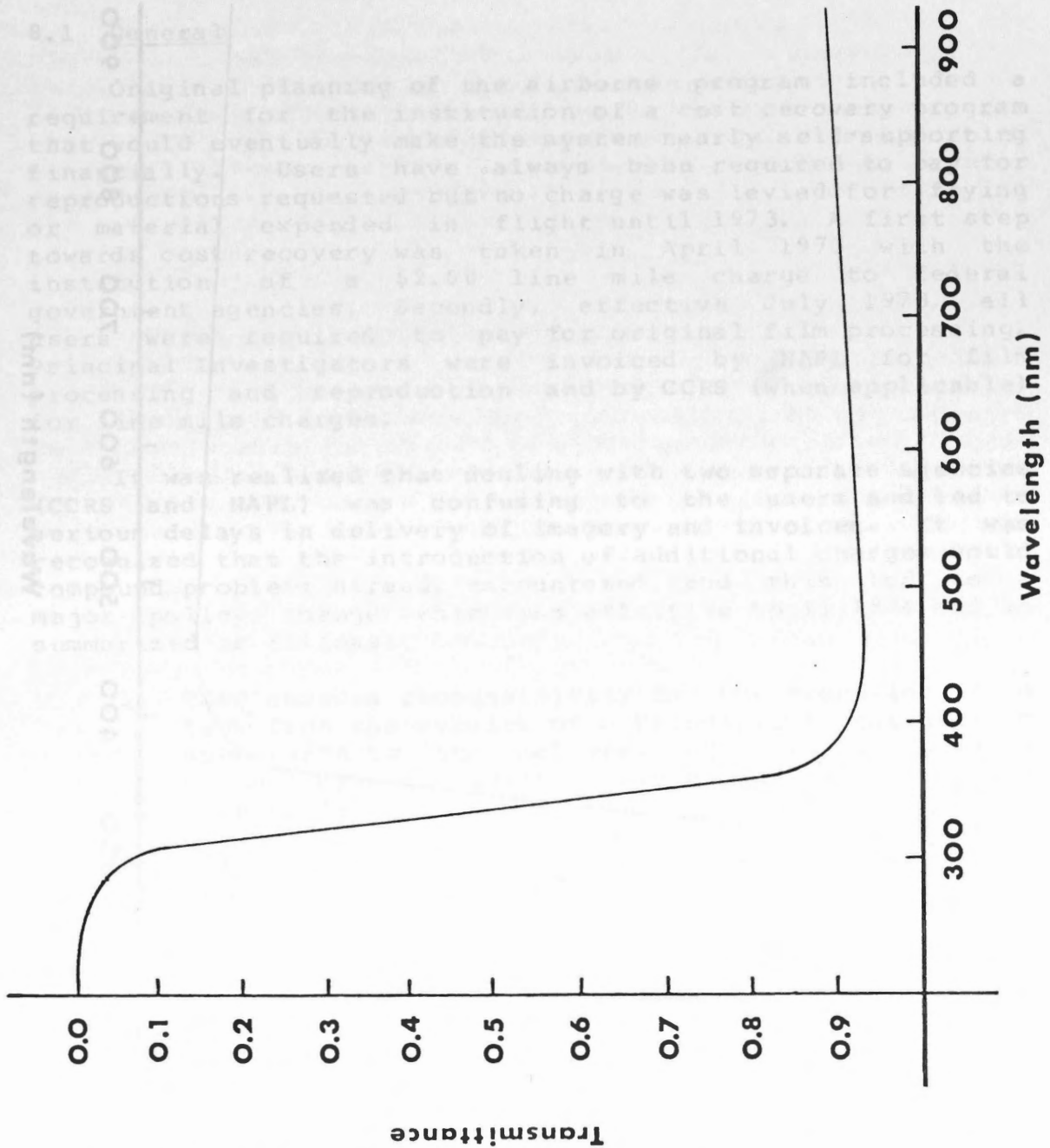

Figure 26 -- Falcon Camera Hatch Spectral Transmission

7.12 Transmittance - Aircraft Camera Hatch - Convair

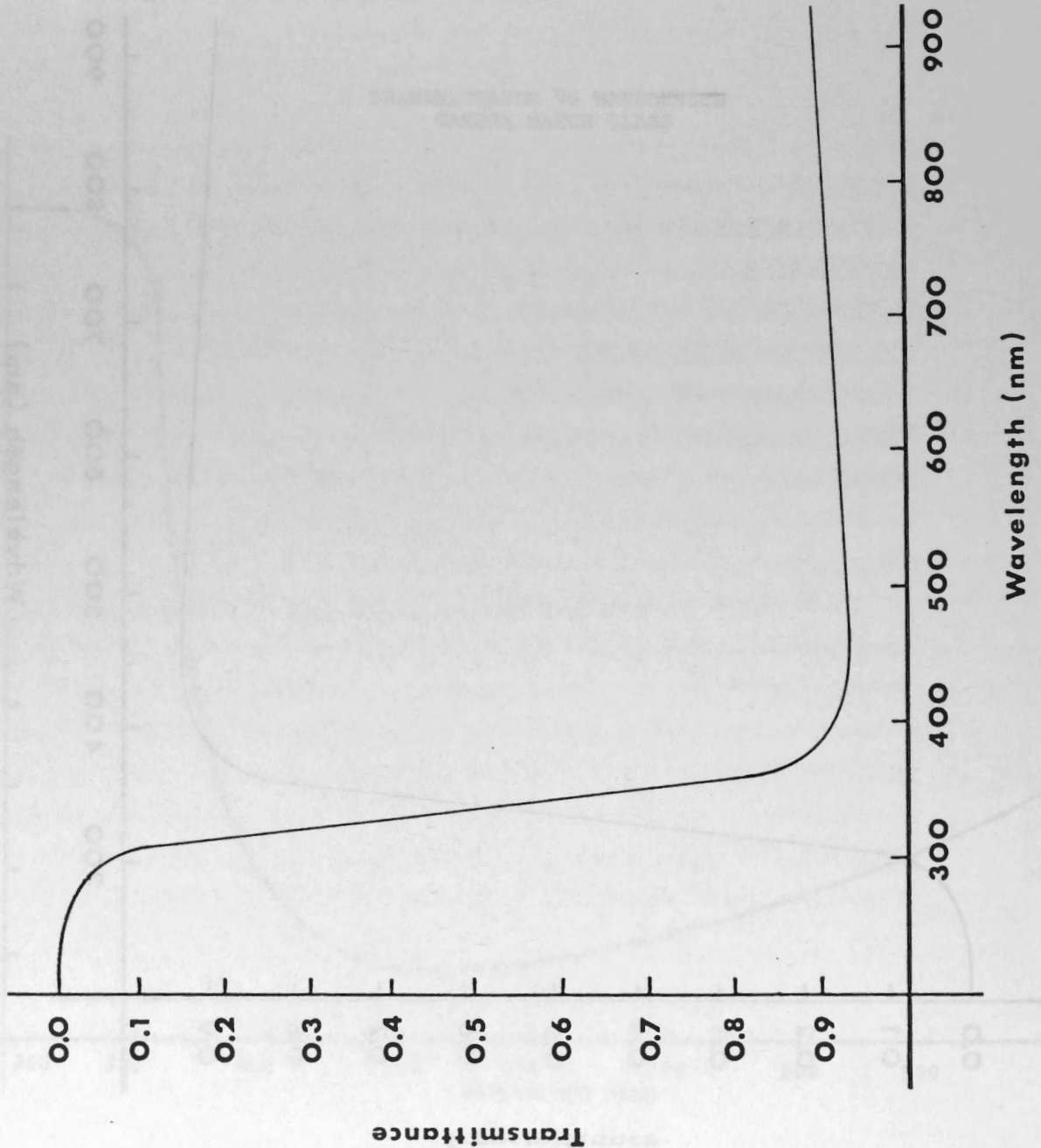

Figure 27 -- Convair Camera Hatch Spectral Transmission

8.0 COST RECOVERY

8.1 General

Original planning of the airborne program included a requirement for the institution of a cost recovery program that would eventually make the system nearly self-supporting financially. Users have always been required to pay for reproductions requested but no charge was levied for flying or material expended in flight until 1973. A first step towards cost recovery was taken in April 1973 with the institution of a \$2.00 line mile charge to federal government agencies. Secondly, effective July 1973, all users were required to pay for original film processing. Principal Investigators were invoiced by NAPL for film processing and reproduction and by CCRS (when applicable) for line mile charges.

It was realized that dealing with two separate agencies (CCRS and NAPL) was confusing to the users and led to serious delays in delivery of imagery and invoices. It was recognized that the introduction of additional charges would compound problems already encountered and this led to a major policy change which was effective April 1974 and is summarized as follows:

1. CCRS assumes responsibility for the execution of a task from the receipt of a Principal Investigator's submission to the delivery of original imagery requested, including invoicing and accounts receivable.
2. NAPRC will continue to process original imagery and reproduce imagery as directed on the task sheet. These services will be performed under a direct contract with CCRS.
3. CCRS retains sole responsibility for the reduction of data from magnetic tape to hard copy, the signal processing and enhancement (density slicing) of such data and the direct supply of resulting imagery to the Principal Investigator. Secondary orders for duplicate negatives taken directly from the tape will be completed by CCRS. Positives from existing original negatives (up to July 1975) are to be obtained from NAPL. Users will be invoiced

by the applicable agency.

4. NAPL retains its function as a repository of imagery for storage and the agency responsible for fulfilling requests for secondary or on-going reproduction from stored photographic imagery. Users will be invoiced directly by NAPL for services rendered.

8.2 Applicable Charges

8.2.1 Line Mile -

Charges by CCRS for flying each sensor line mile are \$18.50 for experienced users and \$9.25 for first time users with a \$100.00 minimum line mileage charge. An additional two line miles will be added for every line over one line to partially cover the cost of end turns. A sensor line mile is one nautical mile flown with sensors operating, regardless of the number of sensors in use. e.g. The same line mile charge will be levied whether one or six sensors are in operation. Mileage expended in transit to and from the test site is not subject to a charge. Line miles will be measured between sensor start-stop points drawn on the original flight maps as confirmed by the index map. These points, in the case of area cover, will normally extend one-half the line spacing outside the boundary of the requestors target area. This extra coverage is designed to ensure full stereo coverage of the requestors area and to give the sensor operators some leeway in turning sensors on and off. No charge will be levied for lines shown on the index map as extending beyond the start-stop points or for cover not shown on the index map. Charges may be pro-rated on the performance of the primary sensor named by the requestor. Every effort will be made to fairly evaluate the degree of success of each flight. Doubtful cases will be discussed with the requestor prior to invoicing action being taken.

8.2.2 Material Expended -

Film and magnetic tape expended during the flight are provided by CCRS. Users will be invoiced at current prices for estimated footages used. If a full roll is expended, charges will reflect the roll price. Between twenty and thirty feet of film are utilized for leader, trailer and mandatory blanks between exposures for each roll or part roll expended. See Appendix "F" for a brief description of the procedures used in estimating the cost of a flight.

8.2.3 Processing Original Imagery -

NAPRC will process all original photographic imagery and invoice CCRS for services rendered. CCRS will invoice users for this amount. CCRS will reduce taped data to hard copy and invoice users for material expended.

8.2.4 Reproduction -

NAPRC will produce all reproductions requested on the original task sheet and invoice CCRS accordingly. CCRS will invoice users to recover these funds.

8.2.5 Summary -

CCRS will invoice users for all charges applicable to each flight. These charges are estimated prior to the flight and are listed on the reverse side of the task sheet. The invoice will be for an amount equal to or less than the estimated amount unless the Principal Investigator has requested subsequent changes or additions to his project. The cost estimate will be based on the following price structure:

1. Full cost recovery for material expended in photography, processing and reproduction including cost of magnetic tape.

2. \$18.50 per line mile for all experienced users.
3. \$9.25 per line mile for all first time users.
4. 100.00 minimum line mileage charge.
5. An additional two line miles for every line over one line to partially cover the cost of end turns.
6. No transit charges to and from target areas.

Invoices will contain the following itemized information:

1. Users purchase order or file number
2. Task number and flight date
3. Total agreed charges as per task sheet
4. Any adjustments
5. Net charge

8.3 User's Calculations

On the back of each task sheet, requestors will be provided with a written cost estimate for their particular task prior to the actual operation. To assist investigators in the calculation of possible costs of photographic coverage for any task prior to the submission of a flight request, scale and coverage tables have been attached as Appendix "B".

Exposures required to complete any task may be calculated and applied to film costs contained in Section 6; processing and reproduction charges provided in Appendix "A". Ten percent should be added to all totals obtained to cover leader and trailer on each roll or part roll of film expended. Exposures normally obtained per roll of film are as follows:

1. Black and white 9 inch X 250 feet -- 280 exposures
2. Colour 9 inch X 200 feet -- 225 exposures
3. Black and white 70 mm X 150 feet -- 700 exposures
4. Colour 70 mm X 100 feet -- 460 exposures

8.4 Fiscal Year 1977/78

Prices for expendable items may increase somewhat due to increased material costs. Note that the price of film increased thirty percent during 1974/75. Material costs will vary with the types of sensors used and the product requested. i.e. Original recording costs for the completed ADAS system using 14 channels on the Mincom recorder will only double those incurred at present when 4 channels are used. Some costs will be incurred in the reduction of data to usable form but these cannot be predicted at this time.

Although a firm price schedule has not yet been set for the 1977/78 fiscal year, the following structure is probable:

1. Full cost recovery for material expended in photography, processing and reproduction as is now in effect.
2. \$18.50 per line mile for all experienced users.
3. \$9.25 per line mile for first time users.
4. \$100.00 minimum line mileage charge.
5. An additional two line miles for every line over one line to cover the cost of end turns.
6. No transit charges to and from target areas.

9.0 VISUAL LIBRARY

9.1 General

The Canada Centre for Remote Sensing received approximately 120 requests per year to perform remote sensing flights covering a wide range of studies within many disciplines. Some requestors were aware of projects similar to their own and were fully cognizant of data that could be obtained by utilizing various types of sensors on an airborne platform. However many were totally unfamiliar with the remote sensing concept in general, or in particular, as it applied to their problem. In this instance the CCRS Airborne Operations Section provided all possible assistance in answering questions pertaining to previous projects, recommended sensors, film/filter combinations, spectral bands, scale, reproduction, etc.

9.2 Data Retrieval

To ensure that all possible information is immediately available, the Airborne Operations Section has initiated a computer based data retrieval system. The computer program is derived from statistics maintained on each project flown since the inception of the airborne program, and is capable of providing the technical details of each flight carried out. Programming permits group retrieval under such headings as discipline, sensor system, geographical location, etc. Although this system provides technical details, it cannot, with a few exceptions, provide information regarding the success or failure of a mission in achieving the aim of the requestor.

9.3 Visual Library

It has been necessary therefore to create a visual library that contains sample imagery obtained on each project. Holdings are segregated by discipline and further subdivided into specific areas within each discipline. i.e. Agriculture: (a) Soil Moisture; (b) Land Use; (c) Crop Disease; (d) Crop Damage; etc. Files include a short resume of the project with comments and recommendations of

the Principal Investigator. Interim and final reports are included in the file on receipt. This system, when cross referenced to the computer program, provides maximum assistance to users and potential users of remotely sensed imagery in that it reflects the views of "actual users" in the field rather than the purely technical and/or theoretical views of CCRS staff.

9.4 Reports

During our five years of operation we have received some very excellent reports from Principal Investigators and these have been utilized extensively to further the knowledge of remote sensing techniques within the scientific community in Canada. Unfortunately the reports represent returns from less than ten percent of our users. You will understand our concern therefore, with the retrieval of information relating to current projects.

Each investigator can provide useful information for inclusion in the "Visual Library - Data Bank" system. Convenient reporting forms are mailed to each user approximately three months after imagery is delivered. Prompt completion and return to CCRS Airborne Operations Section ensures that a report summary is available on each project. This return does not preclude the requirement for the submission of interim or final reports on results obtained. Please note that except for the completion of preliminary forms, we are not asking for a report prepared especially for CCRS. Copies of internal or published reports are quite adequate for the intended purpose.

10.0 A LOOK TO THE FUTURE

10.1 Sensors

Under the stated terms of reference, one of the main objectives of CCRS is to remain current with the latest developments in remote sensing techniques and to sponsor, procure and evaluate new sensing devices that will meet the specialized requirements of investigators. CCRS has funded the development of a number of sensing devices and has purchased and modified others to produce high quality results. The following pages describe some of those sensing devices now either available or in the specification stage. The present status of each sensor is stated.

10.1.1 Microwave Scatterometer (Ryan Model 720)

Description: Measures absolute radar backscattering coefficient of terrain as a function of look angle from nadir

Spectral Characteristics: Operates at 13.3 GHz (2.25 cm. wavelength)

Absolute Accuracy: Limited by errors in the knowledge of the antenna two way gain patterns. The absolute accuracy of the scattering coefficients for horizontally polarized transmitted and received radiation is approximately plus or minus 1 db. Somewhat higher errors exist for the other polarization combinations, and values of plus or minus 3 db. are possible for the larger (50 - 60 degree) incident angles. Relative accuracy (typically plus or minus 0.5 db) depends on the desired ground resolution.

Data Output: Two channel analog recording (like and cross polarized returns). Non real time digital and analog processing is possible to obtain scattering

coefficients as a function of angle.

Antenna: Fan beam 60 degree fore and aft of plane along track, 3 degree beam width across track. Either horizontally or vertically polarized signals can be transmitted while both horizontally and vertically polarized received signals are recorded simultaneously.

Status: Under evaluation in sea-ice and sea-state experiments

10.1.2 Pulsed Laser Fluorosensor

Description: This is an active day and night profiling device for identifying and mapping the distribution and concentration of oil spills, water pollution, chlorophyll, algae, and tracer dyes. The system is also designed to classify different types of oils. Further applications will be developed which may be of interest to geological, agricultural and silvicultural users. The sensor is potentially able to classify or identify plant species, soil types, rock outcrops, tree types and plant stress. The sensor may also be of use in mapping the effectiveness of spraying operations or locating fish schools. The sensor operates by exciting and detecting the characteristic fluorescence emission from substances on the surface of the land or water.

Source: Pulsed nitrogen laser
Peak pulse power - 1 MW
Pulse width - 4 ns.
Repetition rate - 100 Hz
Wavelength - 337 nm
Divergence - 1 X 3 mrad. full angle (across x along track)

Detector: 20 cm telescope with spectrometer,

photomultipliers and photodiodes. Receiver is unpolarized.

Physical Parameters Measured:

Fluorescence emission spectrum:

- 16 channels (20 nm/channel nominal width).
- 1st centred a 380 nm (water raman band).
- 16th centered at 680 nm (chlorophyll fluorescence band).

Fluorescence lifetime:

2 channels user selected.

Standard configuration:

- 390 - 450 nm "blue lifetime"
- 450 - 690 nm "red lifetime"

Absolute fluorescence intensity.

Lidar or radar altitude of aircraft.

Operating Conditions:

Day or night under conditions of clear visibility.

System limited by fog.

Profiling sensor -- foot print directly under aircraft.

Altitude less than 2000 ft. above terrain.

Data Output: Real time display of spectral data on television monitor, rolling strip chart of a selected channel, emission spectrum, and alphanumeric data. Limited real time signal averaging plus in-air play back of data. Data recorded on 9 track CCT (NASA-JSC non imagery standard format).

CCT contains:

- time (internal to sensor)
- 16 spectral channels
- 2 lifetime channels
- laser power
- receiver gain
- lidar/radar altitude
- 2 navigation parameters selected from ARINC bus

Data also recorded on MUX track of ADAS.

Sensor interfaces to:

- ARINC bus (navigation parameters).
- Radar altimeter (altitude and receiver triggering information)
- ADAS MUX track (output and correlation with other parameters)
- Time Code Generator -- Synchronizing pulses
- Video tape recorder (records real time display)
- 9 track CCT -- stand alone output and replay ability

Status: Single engineering prototype to begin flight tests
Jan. 1977. System will be ready for joint experiments
Spring 1977.

NOTE

The laser fluorosensor referred to in earlier versions of this Information Bulletin will no longer be available as the newer instrument represents a considerable improvement.

Some leading specifications of the old instrument were:
Laser peak power -- 100kW
Pulse width -- 10 ns.
Divergence -- 4 x 14 mrad. (across x along track)
Telescope field of view -- 14 mrad.
Detectors -- 2 channels, photomultiplier tube with filters
Operation conditions -- night time only
Output -- Oscilloscope, chart recorders, MUX track of ADAS

The other parameters are similar.

10.1.3 CW Laser Fluorosensor

Description: This is an active nighttime profiling device for mapping distribution, identification and concentration monitoring of oil spills, water pollution, chlorophyll, algae and tracer dyes. It operates by exciting and detecting characteristic fluorescence emission from the target substances. Because of the wavelength used, this sensor should be particularly effective at mapping the fluorescence of chlorophyll. The system can be modified with relative ease to make active reflectance and depolarization measurements at the laser wavelengths. Additional lasers may be incorporated. It is potentially feasible to combine this system with the Medium Resolution Spectrometer so that fluorescence spectra can be obtained.

NOTE

The principle on which the operation of this fluorosensor depends was developed at the Inland Waters Directorate of Fisheries and Environment Canada.

Source: CW HeCd Laser

Average Power -- 20 mW

Wavelength -- 442 nm (325 nm also available)

Beam divergence -- <1 mrad.

Modulation frequency -- 550 Hz

Detector: telescope -- filter -- photomultiplier
Photomultiplier may be selected depending on application.

Single spectral channel

Standard filter set:

-- high pass cut-on at 465 nm

-- interference filters centered at 400, 440, 520,
540, 600, 680 nm (10 nm bandwidth)

Receiver is unpolarized in standard configuration.

Physical Parameters Measured: Fluorescence emission of target, spectral discrimination with selected interference filters.

Operating Conditions:

Nighttime operation under conditions of clear visibility.

System limited by fog and haze.

Profiling sensor, footprint directly under aircraft.

Laser beam visible in Low Light Level Television image.

Altitude less than 1000 ft. above terrain.

Data Output:

Amplitude of fluorescence return in selected channel.

Laser power.

MUX track ADAS (preferred) may be superimposed on Low Light Level Television image.

Status: Single unit being prepared for limited production use in standard configuration. To be available for user experiments during 1977.

10.1.4 Lidar Bathymeter (Laser Hydrography Project)

Description: This is an active device for measuring water depths from an airborne platform. It is for use over relatively clear and/or shallow bodies of water such as lakes, rivers and coastal areas. It operates by sending a light pulse to the water's surface. This

light pulse is reflected off the air/water interface and scattered from the lake bottom back to the receiver in the aircraft. The depth is obtained by measuring the time interval between the arrival of the light pulses returning from the top and bottom surface of the water. The sensor may also find application to the measurement of turbidity, sharp density changes in the water and increased density of particles in the water such as may be trapped by the thermoclyne.

Source: Pulsed frequency-doubled Nd-YAG laser.

Peak pulse power -- 9 MW
Pulse width -- 8 ns
Repetition rate -- 10 Hz
Wavelength -- 530 nm
Divergence -- variable -- 4-40 mrad.

Detector: Telescope and gated photomultiplier with field of view corresponding to that of laser.

Physical Parameters Measured:

Water depth; back scatter as a function of depth.
Resolution -- better than 0.3 m in depth
Minimum depth -- less than 1 meter
Maximum depth -- to be 6 attenuation lengths for wavelength used (530 nm). This corresponds to approximately 10 meters in relatively turbid waters and greater than 30 meters in clear ocean water.

Operating Conditions:

Day or night under conditions of relatively clear visibility.
System limited by fog.
Altitude less than 8000 ft. above terrain/water.

Data Output:

Lidar returns stored on 9-track CCT in a format similar to the NASA-JSC non-imagery standard.
Laser power, lidar altitude and other system parameters stored on MUX track of ADAS.

Status: Single 2nd generation unit presently under active development. Preliminary flight trials to begin mid-summer 1977. Joint tests of lidar hydrography and photo hydrography systems to begin fall 1977.

NOTE

A previous version of the lidar bathymeter referred to in earlier versions of this Information Bulletin will no longer be available as the newer instrument will provide considerable improvement in overall system performance.

Some leading specifications of the old instrument were:

Pulsed neon laser

Peak pulse power -- 20 kW

Pulse width -- 3 ns.

Repetition rate -- 100 Hz

Wavelength -- 540 nm

System divergence -- 4 x 14 mrad. (along x across track)

Detector -- single photomultiplier

With the exception of the data acquisition system, the other specifications were similar.

10.1.5 Linear Detector Array Spectrometer

Developed by University of British Columbia and the Department of Fisheries and Environment, Pat Bay, British Columbia

Description: The spectrometer consists of an array of 256 diodes which are simultaneously illuminated by light dispersed by a grating. A manual arrangement enables viewing an opal aircraft ceiling sky-port, dark current or reflected radiance.

Spectral Characteristics: Normally 400 to 800 nm (approximately 1.6 nm per diode) but could be a 400 nm band within 400-1100 nm.

Temporal Characteristics: The diode array is scanned in 0.1 seconds after an adjustable time exposure from 0.5 to 4 seconds.

Spatial Characteristics: 1 by 10 mrad.

Sensitivity: Of silicon diodes -- 400 nm to 1100 nm.

Data Output: Repeating sequence of 256 sampled voltage levels digitized and recorded on CCT transport.

Physical Parameters Measured: Visible and infrared upwelling and downwelling radiation at the aircraft.

Status: Under testing and evaluation.

10.1.6 MPPH Four Barrel Photometer

Miller-Pieau Photometer (MPPH), developed by York University.

Description: 4-barrel photometer; each barrel consists of an interference filter, lens and silicon photodiode

detector. The filters are readily changeable.

Spectral Characteristics: Pass-band of each interference filter may be selected between 300 nm and 800 nm. Spectral resolution is determined by the filter selected. Each barrel time-shares between viewing the upwelling scene energy and the downwelling energy from an opal screen skylight in the aircraft ceiling.

Spatial Characteristics: Variable 10, 20, 50 and 100 mrad.

Temporal Characteristics: Thumbwheel selectable scene and solar reference viewing times, typically 20 seconds scene, 2 seconds solar.

Filters Available:

Central Wavelength (nm)	Bandwidth (nm)
445	11
460	10
526	11
566	11
581	10
687	11
710	10
750	10
982	125

A set of 4 Lansat compatible spectral filters

Detectors: Silicon photodiodes for each channel.

Data Output:

Analog (0-5 volts) from each barrel plus analog gain factor.

Digital recording on magnetic tape via ADAS.

Status: Semi-operational.

10.1.7 Multispectral Line Scanner (MSS)

Description: A multichannel optical mechanical line scan spectrometer that records energy reflected or emitted from the Earth's surface.

Internal Design Features:

Field of view 90 degrees

Roll stabilized

Calibration:

2 thermal black bodies (hot and cold)

1 dark reference

1 UV/visible calibration lamp

Channels: Any two of A, B, C

Detector (A) - cooled mercury cadmium telluride - 8-14 um

Detector (B) - cooled indium antimonide - 3-5 um

Detector (C) - 10 channel prism polychrometer - silicon photodiodes from 400-1100 nm

Also includes Landsat bands synthesized from (C), and S-bend correction.

Spatial Resolution: 2.5 mrad.

Temporal Characteristics: 100 (non-preferred), 50, 25, or 12.5 scans per second (selectable).

Data Output: Digitally recorded on wideband magnetic tape recorder.

Physical Parameters Measured: Infrared radiation emitted from the earth's surface; solar radiation reflected from the earth's surface.

Status: Under evaluation at CCRS.

10.1.8 Multi-detector Electro Optical Imaging System (MEIS)

Description: This prototype unit consists of two 512 element linear photodiode arrays at the focal plane of two lenses. Spatial scanning is achieved in a pushbroom fashion as the sensor is moved forward by the aircraft platform.

Spectral Characteristics: The imager has the spectral response of silicon photodiodes (0.38 to 1.1 μm). Spectral isolation filters are easily inserted into the sensor field of view.

Temporal Characteristics: Readout times selectable from 12.5, 25, 50 and 100 scans/second.

Spatial Characteristics: 28 degree swath (1 mrad. instantaneous FOV).

Sensitivity: Depends on spectral filter and scan speed selected.

Data Output: Mates with the Multi-Spectral Scanner (MSS) and reads out in the same digital format as the MSS.

Physical Parameters Measured: Upwelling reflected and scattered radiance.

Status: Under test and evaluation.

10.1.9 Gas Correlative Cell Spectrometer (Gaspec)

Description: This sensor operates as a passive infrared non-dispersive gas analyser, in which the incoming radiation is differentially passed through (and correlated with) a gas cell containing a sample of the target gas to be detected.

Parameter Measured: Integrated path length burden of trace atmospheric gas.

Spectral Characteristics:
4.6 +/- .05 um for CO

Temporal Characteristics: Two detectors perform an effective "double-beaming" measurement. The output is normally filtered with a one second integration.

Spatial Characteristics: 20 mrad diameter field of view.

Sensitivity: 3 ppm-meters CO at 300 K gas temperature against a cold background temperature. Sensitivity decreases as the gas and background temperatures approach equality.

Data Output: Analog (0-5 volts) from (a) differential cell transmission; (b) radiometric single cell signal.

Status: Under test and evaluation.

10.1.10 Low Light Level Television

COHU model 2856

Description: A TV camera employing a silicon intensified vidicon tube with separate front end image intensifier (ISIT), capable of imaging low light level targets at night.

NOTE

The camera has a number of limitations which should be considered before undertaking a project with this sensor. The camera is unable to respond to the light level typical of those obtained from a starlit or overcast night sky. It does, however, provide good television images in twilight and moonlight. A second point of which the potential user should be aware is that bright spots in an otherwise dark image tend to bloom. For example, the lights of a farmhouse surrounded by fields will tend to show up as a large white mass, actually obscuring all detail of the farmyard. Another example may be seen when cars on an unlit highway become white blobs moving down the road. This effect is more pronounced the lower the ambient illumination.

Internal Design Features:

Lens - 5.7 mm, f 1.8

Field of view - 96 degrees X 72 degrees

Extended dynamic range from combination of AGC, automatic iris control and automatic neutral density

filter wheel

Spectral Characteristics: Dependent on filters employed.
(Sensitive without filters from near UV to near IR)

Filters:

UV blocking - cut-on 370 nm
UV blocking - cut-on 389 nm
Uv bandpass - centred 330 nm
Blue bandpass - centred 460 nm
Blue bandpass - centred 470 nm

Data Output: Standard NTSC compatible TV mixed sync and video. (Can be recorded on standard video tape recorder)

Status: Operational

Available: One

10.2 Systems

If new sensing devices are to be introduced into the Airborne Program it is necessary to obtain or design systems that will ensure their most efficient operation. Systems currently in being or proposed are described in the following pages. Present status is stated.

10.2.1 Airborne Data Acquisition System (ADAS)

Description

ADAS is a mini-computer based airborne data acquisition

system which is used to gather data from a wide variety of low-speed and high-speed sensors and record this data digitally on a 14 track Mincom tape recorder. One track is used for each of: reference, time code and multiplex track data (MTD). Line scanner data is digitized and recorded on as many tracks as are required, typically two. The remaining tracks can be used for conventional analog or digital recording as required. The system is operated using a keyboard and video display, and provides extensive in-flight checks of recorded data.

Multiplex Track Data (MTD) Recording

The multiplex track contains data from a time code generator, up to 32 low speed sensors, and an LTN-51 inertial navigation system. This data is routed through the ADAS computer, and is recorded in "frames" of 150 - 16-bit words at a rate of 100 frames per second. Each frame includes the time to 1 ms. A multiple of two 16-bit words (e.g. 2 or 4 words) are recorded from each low speed sensor in each frame. The following low speed sensors are currently interfaced to the system: RC-10 camera, PRT-5 Precision Radiation Thermometer, Garrett AFTS-23 Digital Pressure Monitor, GSN-500 VLF navigation system, Marconi Doppler MC712, MSS-Hystogram, Barringer Laser Fluorosensor, Honeywell Radar Altimeter and 3AD8 triple A/D converter unit. The navigation data from the LTN-51 includes longitude, latitude, heading, groundspeed, track angle, X and Y velocities, direction cosines and remainder terms, high accuracy roll, pitch and aximuth, and vertical quantizer. The navigation data is updated every 50 ms (except longitude, latitude, heading, groundspeed and track angle which are updated about once per second). The direction cosines can be later processed on a computer to obtain high accuracy position information. The MTD frames also contain camera firing information each time an RC-10 camera takes a picture. A special "trailer" MTD frame at the end of each flight line contains a cumulative index of all the flight lines on the roll of tape.

Status

An ADAS system is presently installed in the Convair 580 and the DC3 C-GRSA. These two systems are available for the recording of digital data from a complement of sensors and navigation equipment.

10.2.2 Ground Recovery and Monitoring System (GRAMS) -

Description

GRAMS is a mini-computer based playback system for "quicklook" recovery of data recorded on Mincom magnetic tape using the ADAS system. Data is played back directly from the Mincom tape, and outputs are available on a chart recorder, an alphanumeric printer and a film printer.

The following products are available:

Trailer Printout

This is a one-page list of the flight lines that were recorded on a roll of magnetic tape, giving flight line number, start time, end time and ending status.

Camera Firings Printout

This is a printout of all the camera firings (RC-10) between operator-specified times. The list includes camera roll number, time, latitude, longitude, track angle, azimuth, pitch, roll and altitude.

Navigation Data Printout

This is a list of the 30-odd LTN-51 parameters recorded by ADAS, giving values every n seconds. The parameters include longitude, latitude, heading, groundspeed, track

angle, X and Y velocities, direction cosines and remainder terms, roll, pitch and azimuth.

Raw Hexadecimal Frame Printout

This is a fundamental printout of the data stored in the "frames" of MTD data recorded by ADAS. The data is printed in hexadecimal, with no conversion or special formatting.

Chart Recorder Tracing

This is a 2-pen chart recorder tracing of any two parameters from the MTD data recorded by ADAS. The data can be from sensors, e.g. PRT-5 temperature, or from the LTN-51 navigation system, e.g. roll angle.

Line Scanner Film Image

This is a strip film of line scanner data using information which was recorded via the one-channel digital recording feature (WADAB) of ADAS. Each film begins with a header which contains an 11-step grey scale and annotation of flight line number, date flown, and certain setup parameters. The header is followed by the line scanner image, which contains: (1) timing marks at 5-second intervals; (2) periodic annotation of time, latitude, longitude, heading, groundspeed and altitude; and (3) optionally two superimposed tracings identical to the chart recorder tracings described above. The thermal data may be transformed by a lookup table to produce density slicing, temperature expansion, contouring, etc.

Status

GRAMS is currently used primarily for developmental work and checking data tapes from ADAS, playback of data in support of sensor development and quicklook for specialized

projects.

10.2.3 Inertial Navigation System (INS) -

Description: The LTN-51 is a self contained navigation system which operates by sensing aircraft accelerations with a gyro-stabilized platform. The system conforms to the ARINC 561 specifications.

Internal Modifications: High resolution resolvers with first order accuracy of 30 seconds of arc for pitch, roll and azimuth. Vertical quantizer to quantize outputs from vertical accelerometer.

Accuracy: Up to 2 km per hr drift in latitude and longitude values

Reliability: MTBF >1000 hours

Data Output to ADAS (through INS - ADAS Interface): Pitch, roll, azimuth from high resolution resolvers. Vertical acceleration from vertical quantizer. 25 selectable parameters. e.g. direction cosines, horizontal velocity, etc.

Status: Each of the four CCRS aircraft is configured to accept an INS and three systems are available.

10.2.4 VLF NAVIGATION SYSTEM -

Description: VLF is a long-range, very low frequency

hyperbolic navigation system which in time will provide global fixing coverage from eight transmitters. Some systems are similar in design to the ARINC 561 specification.

Spectral Characteristics: Transmitter frequencies: 10.2, 11.3 and 13.6 KHz

Absolute Accuracy: 1.5 to 3 kilometers when appropriate corrections applied.

Range: 10,000 to 15,000 km

Reliability: 1000 to 1500 hours MTBF

Data Output: From airborne receiver

Synchro/digital - command track
- command heading
- bearing to destination

DC voltage/digital - crosstrack deviation
- to/from indication
- groundspeed
- distance to go
- present position
- estimated time en-route

Status: The DC3 C-GRSA and the Convair 580 are configured to accept the VLF system and one system is available.

10.2.5 Doppler Navigation System -

Description: Marconi Doppler CMA 712 is an active self contained navigation system. It uses beam intersection techniques in order to measure continuously the ground

speed and drift angle. Using this data with heading information from the compass system or from the INS the navigation computer provides position information in digital or analogue form. Roll and pitch are controlled by INS signals.

Performance Data:

Sensor Range - 40 - 50,000 feet
Ground Speed Range - 100 - 999 knots
Accuracy - 0.14 percent (one signal)
Drift Angle Range - 20 degrees
Accuracy - 0.20 percent (one signal)
Automatic acquisition within 30 seconds

Data Output: Ground speed and drift angle in digital format continuously recorded by ADAS

Status: The DC3 C-GRSA and the Convair 580 are configured to accept the Doppler Navigation System and one system is available.

APPENDIX A

NAPL PRICE LIST

A.1 DISTRIBUTION POLICY

DISTRIBUTION POLICY FOR AERIAL PHOTOGRAPHIC PRODUCTS

1. All orders must be fully prepaid, except in the case of customers having an active account. Cheques and money orders must be made payable to the Receiver General For Canada.
2. Terms of payment for all accounts:
NET 30 DAYS
3. All orders will be subject to a \$2.00 handling charge.
4. Shipments having a package weight of 25 lbs or less and valued at less than \$200.00 will normally be by parcel post; having a package weight of more than 25 lbs and/or valued at \$200.00 or more will normally be by rail express. Shipments made by other means of transportation at the customer's request will be so at the customer's expense, usually on a collect basis.
5. No discounts shall be granted to any customer.
6. In the event of an overpayment of \$1.00 or more, the amount of the overpayment shall be returned to the customer, by postal money order when the amount does not exceed \$4.99 and by the Receiver General for \$5.00 or more. Overpayments of less than \$1.00 will not be refunded unless the customer so requests.

A.2 PRICE LIST

<u>ITEM DESCRIPTION</u>		<u>PRICE</u>
<u>Contact Print (up to 10")</u>		
2701	Black and White	ea. \$1.40
2702	B&W Hand Process	1.75
2703	B&W Tone Matched	5.00
2801	Colour (Negative Original)	3.00
2802	Colour (Positive Original)	3.50
<u>Contact Transparency (Up to 10")</u>		
3101	Black and White	ea. \$2.50
3102	Colour (Negative Original)	5.50
3103	Colour (Positive Original)	6.00
<u>Continuous Contact Printing</u>		
(Minimum charge - 25 feet)		
3108	9 1/2" Black and White	per foot \$0.75
3104	Colour (Negative Original)	1.25
3106	Colour (Positive Original)	1.50
3201	70 mm Black and White	0.50
3202	70 mm Colour (Negative Original)	0.75
3203	70 mm Colour (Positive Original)	1.00
<u>Continuous Contact Transparency</u>		
(Minimum charge - 25 feet)		
3109	9 1/2" Black and White	per foot \$1.00
3105	Colour (Negative Original)	4.00
3107	Colour (Positive Original)	2.25
3204	70 mm Black and White	1.00
3205	70 mm Colour (Negative Original)	1.70
3206	70 mm Colour (Positive Original)	1.40
<u>Enlargement (Paper Prints)</u>		
2901	Black and White 10 x 10"	ea. \$5.50
2902	Black and White 15 x 15"	6.75
2903	Black and White 20 x 20"	7.75
2904	Black and White 30 x 30"	11.00
2905	Black and White 40 x 40"	13.00
2906	Black and White 40 x 60"	16.00
3001	Colour (Negative Original) 10 x 10"	19.50
3002	Colour (Negative Original) 15 x 15"	22.50

A.3 PRICE LIST (CONT.)

	ITEM DESCRIPTION	PRICE
<u>Enlargement (Paper Prints Cont'd.)</u>		
3003	Colour (Negative Original) 20 x 20"	ea. \$25.00
3004	Colour (Negative Original) 30 x 30"	40.00
3005	Colour (Negative Original) 40 x 40"	50.00
3011	Colour (Positive Original) 10 x 10"	28.00
3012	Colour (Positive Original) 15 x 15"	32.00
3013	Colour (Positive Original) 20 x 20"	35.00
<u>Enlargement (Film Transparencies)</u>		
3501	Black and White 10 x 10"	ea. \$ 7.75
3502	Black and White 15 x 15"	9.00
3503	Black and White 20 x 20"	10.00
3504	Black and White 30 x 30"	16.00
3505	Black and White 40 x 40"	20.00
3506	Black and White 40 x 60"	25.00
3507	Colour (Negative Original) 10 x 10"	22.50
3508	Colour (Positive Original) 10 x 10"	22.50
<u>Continuous Enlargements, 70 mm to 10 x 10"</u>		
(Complete Frame)		
2910	Black and White Print	ea. \$ 1.40
3006	Colour Print (Negative Original)	3.00
3014	Colour Print (Positive Original)	3.50
3509	Black and White Transparency	2.50
3510	Colour Transparency (Negative Original)	5.50
3511	Colour Transparency (Positive Original)	6.00
<u>Photogrammetric Diapositives</u>		
3402	64 mm x .09 Glass	ea. \$ 3.00
3403	110 mm x .11 Glass	3.50
3404	110 mm x .25 Glass	5.00
3406	9 1/2" x .06 Glass	3.90
3407	9 1/2" x .11 Glass	5.50
3408	9 1/2" x .25 Glass	6.25
3409	9 1/2" Film	2.50
3410	Corrections	1.10
<u>Film Processing (Minimum charge - 25 feet)</u>		
3301	Black and White up to 9 1/2"	per foot \$ 0.25
3302	Colour Negative up to 9 1/2"	0.85
3303	Colour Positive up to 9 1/2"	0.85

A.4 PRICE LIST (CONT.)

ITEM DESCRIPTION		PRICE
<u>Roll Negative Duplicating</u>		
(Minimum charge - 50 feet)		
3821	Black and White 70 mm	per foot \$ 0.75
3822	Black and White 9 1/2"	1.25
<u>Negative Duplicating</u>		
3825	Black and White up to 9 1/2"	\$ 3.35
3826	Colour up to 9 1/2"	6.75
3820	Black and White (Large Format)	20.00
<u>Copy Negative</u>		
3836	Black and White up to 10"	\$ 5.50
3837	Colour up to 10"	7.75
3838	Black and White (Large Format)	30.00
<u>Mosaics</u>		
3703	Initial Charge	\$22.00
3701	Black and White Print	4.50
3702	Colour Print	12.00
<u>Miscellaneous Services</u>		
3812	Print Rectification	\$ 5.50
3814	Cardboard Mounting up to 20 x 20"	5.50
3815	Cardboard Mounting up to 30 x 40"	7.00
3816	Linen Mounting up to 20 x 20"	5.50
3817	Linen Mounting up to 40 x 40"	7.75
3818	Spool and Container 9 1/2"	3.75
3819	Spool and Container 70 mm	2.00
3823	Refix or Rewash B&W film	per foot 0.25
3829	Film Annotation	per hour 10.00
3834	Film Inspection	per hour 11.25
3830	Labour, Black and White	per hour 11.25
3831	Labour, Colour	per hour 13.50
3852	Microfiche Index 35 mm	3.00
3853	Microfilm Cart. 16 mm	25.00
3801	Flight Line Index Map	1.50
3900	Handling Charge	2.00
3835	Material Recovery	at cost

A.5 PRICE LIST (CONT.)

<u>ITEM DESCRIPTION</u>		<u>PRICE</u>
<u>Black and White Satellite Photomaps</u>		
3804	Contact Print	\$ 10.00
3 8 06	Enlarged Print	40.00
3809	Enlarged Print	115.00
3860	Enlarged Print	20.00
3862	Enlarged Print	75.00
<u>Publications</u>		
8225	2nd Seminar on Air Photo Interpretation	2.00
3840	G.C.S. Catalogue - Newfoundland and Labrador	2.50
3841	G . C . S . Catalogue - Maritimes	2.50
3842	G.C.S. Catalogue - Quebec	4.25
3843	G.C.S. Catalogue - Ontario	4.00
3 8 44	G.C.S. Catalogue - Manitoba	3.00
3845	G.C.S. Catalogue - Saskatchewan	2.50
3846	G.C.S. Catalogue - Alberta	2.50
3 8 47	G . C . S . Catalogue - British Columbia	4.00
3848	G.C.S. Catalogue - Northwest Territories	8.50
3 8 49	G.C.S. Catalogue - Yukon	2.50
3850	G.C.S. Catalogue - Airborne Remote Sensing	8.00
3851	G.C.S. Catalogue - Roll to Microfilm Cartridge (Two Volumes)	12.00
<u>Black and White Satellite Photomaps</u>		
3805	Contact Transparency	\$ 15.00
3807	Enlarged Transparency	45.00
3810	Enlarged Transparency	160.00
3861	Enlarged Transparency	25.00
3863	Enlarged Transparency	90.00
3832	Landsat Master Negative - B&W	\$ 1.50
3833	Landsat Master Negative - Colour	5.00

APPENDIX B

SCALE AND COVERAGE DATA

The following tables give the photo scale, total photo coverage, line spacing, etc. for various sensors over a range of altitudes. The line spacing is based on 70 percent of the total photo coverage. This allows for 30 percent side overlap between parallel lines.

The figures given for the line scanner are approximate and are based on a rectilinearized image with the film transport speed adjusted to match the aircraft's height and velocity.

The tables are produced in Metric as well as Imperial units.

SCALE AND COVERAGE DATA

Focal Length 3.47 Inches
 Format Size 9.00 Inches

RC-10

Height AGL (Ft)	Photo Scale	Total Cov. (nm)	Line Spac. (nm)	Eff. Forward Coverage		Exposures per nm	
				20%	60%	20%	60%
1000	1: 3458	0.43	0.30	0.34	0.17	2.93	5.86
2000	1: 6916	0.85	0.60	0.68	0.34	1.47	2.93
3000	1: 10374	1.28	0.90	1.02	0.51	0.98	1.95
4000	1: 13832	1.71	1.19	1.37	0.68	0.73	1.47
5000	1: 17291	2.13	1.49	1.71	0.85	0.59	1.17
6000	1: 20749	2.56	1.79	2.05	1.02	0.49	0.98
7000	1: 24207	2.99	2.09	2.39	1.19	0.42	0.84
8000	1: 27665	3.41	2.39	2.73	1.37	0.37	0.73
9000	1: 31123	3.84	2.69	3.07	1.54	0.33	0.65
10000	1: 34582	4.27	2.99	3.41	1.71	0.29	0.59
11000	1: 38040	4.69	3.28	3.75	1.88	0.27	0.53
12000	1: 41498	5.12	3.58	4.10	2.05	0.24	0.49
13000	1: 44956	5.55	3.88	4.44	2.22	0.23	0.45
14000	1: 48414	5.97	4.18	4.78	2.39	0.21	0.42
15000	1: 51873	6.40	4.48	5.12	2.56	0.20	0.39
16000	1: 55331	6.83	4.78	5.46	2.73	0.18	0.37
17000	1: 58789	7.25	5.08	5.80	2.90	0.17	0.34
18000	1: 62247	7.68	5.38	6.14	3.07	0.16	0.33
19000	1: 65706	8.11	5.67	6.48	3.24	0.15	0.31
20000	1: 69164	8.53	5.97	6.83	3.41	0.15	0.29
21000	1: 72622	8.96	6.27	7.17	3.58	0.14	0.28
22000	1: 76080	9.38	6.57	7.51	3.75	0.13	0.27
23000	1: 79538	9.81	6.87	7.85	3.92	0.13	0.25
24000	1: 82997	10.24	7.17	8.19	4.10	0.12	0.24
25000	1: 86455	10.66	7.47	8.53	4.27	0.12	0.23
26000	1: 89913	11.09	7.76	8.87	4.44	0.11	0.23
27000	1: 93371	11.52	8.06	9.21	4.61	0.11	0.22
28000	1: 96829	11.94	8.36	9.56	4.78	0.10	0.21
29000	1:100288	12.37	8.66	9.90	4.95	0.10	0.20
30000	1:103746	12.80	8.96	10.24	5.12	0.10	0.20
31000	1:107204	13.22	9.26	10.58	5.29	0.09	0.19
32000	1:110662	13.65	9.56	10.92	5.46	0.09	0.18
33000	1:114121	14.08	9.85	11.26	5.63	0.09	0.18
34000	1:117579	14.50	10.15	11.60	5.80	0.09	0.17
35000	1:121037	14.93	10.45	11.94	5.97	0.08	0.17
36000	1:124495	15.36	10.75	12.29	6.14	0.08	0.16
37000	1:127953	15.78	11.05	12.63	6.31	0.08	0.16
38000	1:131412	16.21	11.35	12.97	6.48	0.08	0.15
39000	1:134870	16.64	11.65	13.31	6.66	0.08	0.15

SCALE AND COVERAGE DATA

Focal Length 6.00 Inches RC-8
 Format Size 9.00 Inches RC-10

Height AGL (Ft)	Photo Scale	Total Cov. (nm)	Line Spac. (nm)	Eff. Forward Coverage		Exposures per nm	
				20%	60%	20%	60%
1000	1: 2000	0.25	0.17	0.20	0.10	5.07	10.13
2000	1: 4000	0.49	0.35	0.39	0.20	2.53	5.07
3000	1: 6000	0.74	0.52	0.59	0.30	1.69	3.38
4000	1: 8000	0.99	0.69	0.79	0.39	1.27	2.53
5000	1: 10000	1.23	0.86	0.99	0.49	1.01	2.03
6000	1: 12000	1.48	1.04	1.18	0.59	0.84	1.69
7000	1: 14000	1.73	1.21	1.38	0.69	0.72	1.45
8000	1: 16000	1.97	1.38	1.58	0.79	0.63	1.27
9000	1: 18000	2.22	1.55	1.78	0.89	0.56	1.13
10000	1: 20000	2.47	1.73	1.97	0.99	0.51	1.01
11000	1: 22000	2.71	1.90	2.17	1.09	0.46	0.92
12000	1: 24000	2.96	2.07	2.37	1.18	0.42	0.84
13000	1: 26000	3.21	2.25	2.57	1.28	0.39	0.78
14000	1: 28000	3.45	2.42	2.76	1.38	0.36	0.72
15000	1: 30000	3.70	2.59	2.96	1.48	0.34	0.68
16000	1: 32000	3.95	2.76	3.16	1.58	0.32	0.63
17000	1: 34000	4.19	2.94	3.36	1.68	0.30	0.60
18000	1: 36000	4.44	3.11	3.55	1.78	0.28	0.56
19000	1: 38000	4.69	3.28	3.75	1.88	0.27	0.53
20000	1: 40000	4.93	3.45	3.95	1.97	0.25	0.51
21000	1: 42000	5.18	3.63	4.14	2.07	0.24	0.48
22000	1: 44000	5.43	3.80	4.34	2.17	0.23	0.46
23000	1: 46000	5.67	3.97	4.54	2.27	0.22	0.44
24000	1: 48000	5.92	4.14	4.74	2.37	0.21	0.42
25000	1: 50000	6.17	4.32	4.93	2.47	0.20	0.41
26000	1: 52000	6.41	4.49	5.13	2.57	0.19	0.39
27000	1: 54000	6.66	4.66	5.33	2.66	0.19	0.38
28000	1: 56000	6.91	4.84	5.53	2.76	0.18	0.36
29000	1: 58000	7.15	5.01	5.72	2.86	0.17	0.35
30000	1: 60000	7.40	5.18	5.92	2.96	0.17	0.34
31000	1: 62000	7.65	5.35	6.12	3.06	0.16	0.33
32000	1: 64000	7.89	5.53	6.32	3.16	0.16	0.32
33000	1: 66000	8.14	5.70	6.51	3.26	0.15	0.31
34000	1: 68000	8.39	5.87	6.71	3.36	0.15	0.30
35000	1: 70000	8.63	6.04	6.91	3.45	0.14	0.29
36000	1: 72000	8.88	6.22	7.11	3.55	0.14	0.28
37000	1: 74000	9.13	6.39	7.30	3.65	0.14	0.27
38000	1: 76000	9.38	6.56	7.50	3.75	0.13	0.27
39000	1: 78000	9.62	6.74	7.70	3.85	0.13	0.26

SCALE AND COVERAGE DATA

Focal Length 1.50 Inches
 Format Size 2.25 Inches

VINTEN

Height AGL (Ft)	Photo Scale	Total Cov. (nm)	Line Spac. (nm)	Eff. Forward Coverage		Exposures per nm	
				20%	60%	20%	60%
1000	1: 8000	0.25	0.17	0.20	0.10	5.07	10.13
2000	1: 16000	0.49	0.35	0.39	0.20	2.53	5.07
3000	1: 24000	0.74	0.52	0.59	0.30	1.69	3.38
4000	1: 32000	0.99	0.69	0.79	0.39	1.27	2.53
5000	1: 40000	1.23	0.86	0.99	0.49	1.01	2.03
6000	1: 48000	1.48	1.04	1.18	0.59	0.84	1.69
7000	1: 56000	1.73	1.21	1.38	0.69	0.72	1.45
8000	1: 64000	1.97	1.38	1.58	0.79	0.63	1.27
9000	1: 72000	2.22	1.55	1.78	0.89	0.56	1.13
10000	1: 80000	2.47	1.73	1.97	0.99	0.51	1.01
11000	1: 88000	2.71	1.90	2.17	1.09	0.46	0.92
12000	1: 96000	2.96	2.07	2.37	1.18	0.42	0.84
13000	1:104000	3.21	2.25	2.57	1.28	0.39	0.78
14000	1:112000	3.45	2.42	2.76	1.38	0.36	0.72
15000	1:120000	3.70	2.59	2.96	1.48	0.34	0.68
16000	1:128000	3.95	2.76	3.16	1.58	0.32	0.63
17000	1:136000	4.19	2.94	3.36	1.68	0.30	0.60
18000	1:144000	4.44	3.11	3.55	1.78	0.28	0.56
19000	1:152000	4.69	3.28	3.75	1.88	0.27	0.53
20000	1:160000	4.93	3.45	3.95	1.97	0.25	0.51
21000	1:168000	5.18	3.63	4.14	2.07	0.24	0.48
22000	1:176000	5.43	3.80	4.34	2.17	0.23	0.46
23000	1:184000	5.67	3.97	4.54	2.27	0.22	0.44
24000	1:192000	5.92	4.14	4.74	2.37	0.21	0.42
25000	1:200000	6.17	4.32	4.93	2.47	0.20	0.41
26000	1:208000	6.41	4.49	5.13	2.57	0.19	0.39
27000	1:216000	6.66	4.66	5.33	2.66	0.19	0.38
28000	1:224000	6.91	4.84	5.53	2.76	0.18	0.36
29000	1:232000	7.15	5.01	5.72	2.86	0.17	0.35
30000	1:240000	7.40	5.18	5.92	2.96	0.17	0.34
31000	1:248000	7.65	5.35	6.12	3.06	0.16	0.33
32000	1:256000	7.89	5.53	6.32	3.16	0.16	0.32
33000	1:264000	8.14	5.70	6.51	3.26	0.15	0.31
34000	1:272000	8.39	5.87	6.71	3.36	0.15	0.30
35000	1:280000	8.63	6.04	6.91	3.45	0.14	0.29
36000	1:288000	8.88	6.22	7.11	3.55	0.14	0.28
37000	1:296000	9.13	6.39	7.30	3.65	0.14	0.27
38000	1:304000	9.38	6.56	7.50	3.75	0.13	0.27
39000	1:312000	9.62	6.74	7.70	3.85	0.13	0.26

SCALE AND COVERAGE DATA

Focal Length 3.00 Inches
 Format Size 2.25 Inches

VINTEN

Height AGL (Ft)	Photo Scale	Total Cov. (nm)	Line Spac. (nm)	Eff. Forward Coverage		Exposures per nm	
				20%	60%	20%	60%
1000	1: 4000	0.12	0.09	0.10	0.05	10.13	20.27
2000	1: 8000	0.25	0.17	0.20	0.10	5.07	10.13
3000	1: 12000	0.37	0.26	0.30	0.15	3.38	6.76
4000	1: 16000	0.49	0.35	0.39	0.20	2.53	5.07
5000	1: 20000	0.62	0.43	0.49	0.25	2.03	4.05
6000	1: 24000	0.74	0.52	0.59	0.30	1.69	3.38
7000	1: 28000	0.86	0.60	0.69	0.35	1.45	2.90
8000	1: 32000	0.99	0.69	0.79	0.39	1.27	2.53
9000	1: 36000	1.11	0.78	0.89	0.44	1.13	2.25
10000	1: 40000	1.23	0.86	0.99	0.49	1.01	2.03
11000	1: 44000	1.36	0.95	1.09	0.54	0.92	1.84
12000	1: 48000	1.48	1.04	1.18	0.59	0.84	1.69
13000	1: 52000	1.60	1.12	1.28	0.64	0.78	1.56
14000	1: 56000	1.73	1.21	1.38	0.69	0.72	1.45
15000	1: 60000	1.85	1.30	1.48	0.74	0.68	1.35
16000	1: 64000	1.97	1.38	1.58	0.79	0.63	1.27
17000	1: 68000	2.10	1.47	1.68	0.84	0.60	1.19
18000	1: 72000	2.22	1.55	1.78	0.89	0.56	1.13
19000	1: 76000	2.34	1.64	1.88	0.94	0.53	1.07
20000	1: 80000	2.47	1.73	1.97	0.99	0.51	1.01
21000	1: 84000	2.59	1.81	2.07	1.04	0.48	0.97
22000	1: 88000	2.71	1.90	2.17	1.09	0.46	0.92
23000	1: 92000	2.84	1.99	2.27	1.13	0.44	0.88
24000	1: 96000	2.96	2.07	2.37	1.18	0.42	0.84
25000	1:100000	3.08	2.16	2.47	1.23	0.41	0.81
26000	1:104000	3.21	2.25	2.57	1.28	0.39	0.78
27000	1:108000	3.33	2.33	2.66	1.33	0.38	0.75
28000	1:112000	3.45	2.42	2.76	1.38	0.36	0.72
29000	1:116000	3.58	2.50	2.86	1.43	0.35	0.70
30000	1:120000	3.70	2.59	2.96	1.48	0.34	0.68
31000	1:124000	3.82	2.68	3.06	1.53	0.33	0.65
32000	1:128000	3.95	2.76	3.16	1.58	0.32	0.63
33000	1:132000	4.07	2.85	3.26	1.63	0.31	0.61
34000	1:136000	4.19	2.94	3.36	1.68	0.30	0.60
35000	1:140000	4.32	3.02	3.45	1.73	0.29	0.58
36000	1:144000	4.44	3.11	3.55	1.78	0.28	0.56
37000	1:148000	4.56	3.20	3.65	1.83	0.27	0.55
38000	1:152000	4.69	3.28	3.75	1.88	0.27	0.53
39000	1:156000	4.81	3.37	3.85	1.92	0.26	0.52

SCALE AND COVERAGE DATA

Focal Length 6.00 Inches
 Format Size 2.25 Inches

VINTEN

Height AGL (Ft)	Photo Scale	Total Cov. (nm)	Line Spac. (nm)	Eff. Forward Coverage		Exposures per nm	
				20%	60%	20%	60%
1000	1: 2000	0.06	0.04	0.05	0.02	20.27	40.53
2000	1: 4000	0.12	0.09	0.10	0.05	10.13	20.27
3000	1: 6000	0.19	0.13	0.15	0.07	6.76	13.51
4000	1: 8000	0.25	0.17	0.20	0.10	5.07	10.13
5000	1: 10000	0.31	0.22	0.25	0.12	4.05	8.11
6000	1: 12000	0.37	0.26	0.30	0.15	3.38	6.76
7000	1: 14000	0.43	0.30	0.35	0.17	2.90	5.79
8000	1: 16000	0.49	0.35	0.39	0.20	2.53	5.07
9000	1: 18000	0.56	0.39	0.44	0.22	2.25	4.50
10000	1: 20000	0.62	0.43	0.49	0.25	2.03	4.05
11000	1: 22000	0.68	0.47	0.54	0.27	1.84	3.68
12000	1: 24000	0.74	0.52	0.59	0.30	1.69	3.38
13000	1: 26000	0.80	0.56	0.64	0.32	1.56	3.12
14000	1: 28000	0.86	0.60	0.69	0.35	1.45	2.90
15000	1: 30000	0.93	0.65	0.74	0.37	1.35	2.70
16000	1: 32000	0.99	0.69	0.79	0.39	1.27	2.53
17000	1: 34000	1.05	0.73	0.84	0.42	1.19	2.38
18000	1: 36000	1.11	0.78	0.89	0.44	1.13	2.25
19000	1: 38000	1.17	0.82	0.94	0.47	1.07	2.13
20000	1: 40000	1.23	0.86	0.99	0.49	1.01	2.03
21000	1: 42000	1.30	0.91	1.04	0.52	0.97	1.93
22000	1: 44000	1.36	0.95	1.09	0.54	0.92	1.84
23000	1: 46000	1.42	0.99	1.13	0.57	0.88	1.76
24000	1: 48000	1.48	1.04	1.18	0.59	0.84	1.69
25000	1: 50000	1.54	1.08	1.23	0.62	0.81	1.62
26000	1: 52000	1.60	1.12	1.28	0.64	0.78	1.56
27000	1: 54000	1.67	1.17	1.33	0.67	0.75	1.50
28000	1: 56000	1.73	1.21	1.38	0.69	0.72	1.45
29000	1: 58000	1.79	1.25	1.43	0.72	0.70	1.40
30000	1: 60000	1.85	1.30	1.48	0.74	0.68	1.35
31000	1: 62000	1.91	1.34	1.53	0.76	0.65	1.31
32000	1: 64000	1.97	1.38	1.58	0.79	0.63	1.27
33000	1: 66000	2.04	1.42	1.63	0.81	0.61	1.23
34000	1: 68000	2.10	1.47	1.68	0.84	0.60	1.19
35000	1: 70000	2.16	1.51	1.73	0.86	0.58	1.16
36000	1: 72000	2.22	1.55	1.78	0.89	0.56	1.13
37000	1: 74000	2.28	1.60	1.83	0.91	0.55	1.10
38000	1: 76000	2.34	1.64	1.88	0.94	0.53	1.07
39000	1: 78000	2.41	1.68	1.92	0.96	0.52	1.04

SCALE AND COVERAGE DATA

Focal Length 1.57 Inches
 Format Size 2.25 Inches

HASSELBLAD

Height AGL (Ft)	Photo Scale	Total Cov. (nm)	Line Spac. (nm)	Eff. Forward Coverage		Exposures per nm	
				20%	60%	20%	60%
1000	1: 7620	0.23	0.16	0.19	0.09	5.32	10.64
2000	1: 15240	0.47	0.33	0.38	0.19	2.66	5.32
3000	1: 22860	0.70	0.49	0.56	0.28	1.77	3.55
4000	1: 30480	0.94	0.66	0.75	0.38	1.33	2.66
5000	1: 38100	1.17	0.82	0.94	0.47	1.06	2.13
6000	1: 45720	1.41	0.99	1.13	0.56	0.89	1.77
7000	1: 53340	1.64	1.15	1.32	0.66	0.76	1.52
8000	1: 60960	1.88	1.32	1.50	0.75	0.66	1.33
9000	1: 68580	2.11	1.48	1.69	0.85	0.59	1.18
10000	1: 76200	2.35	1.64	1.88	0.94	0.53	1.06
11000	1: 83820	2.58	1.81	2.07	1.03	0.48	0.97
12000	1: 91440	2.82	1.97	2.26	1.13	0.44	0.89
13000	1: 99060	3.05	2.14	2.44	1.22	0.41	0.82
14000	1:106680	3.29	2.30	2.63	1.32	0.38	0.76
15000	1:114300	3.52	2.47	2.82	1.41	0.35	0.71
16000	1:121920	3.76	2.63	3.01	1.50	0.33	0.66
17000	1:129540	3.99	2.80	3.20	1.60	0.31	0.63
18000	1:137160	4.23	2.96	3.38	1.69	0.30	0.59
19000	1:144780	4.46	3.13	3.57	1.79	0.28	0.56
20000	1:152400	4.70	3.29	3.76	1.88	0.27	0.53
21000	1:160020	4.93	3.45	3.95	1.97	0.25	0.51
22000	1:167640	5.17	3.62	4.14	2.07	0.24	0.48
23000	1:175260	5.40	3.78	4.32	2.16	0.23	0.46
24000	1:182880	5.64	3.95	4.51	2.26	0.22	0.44
25000	1:190500	5.87	4.11	4.70	2.35	0.21	0.43
26000	1:198120	6.11	4.28	4.89	2.44	0.20	0.41
27000	1:205740	6.34	4.44	5.08	2.54	0.20	0.39
28000	1:213360	6.58	4.61	5.26	2.63	0.19	0.38
29000	1:220980	6.81	4.77	5.45	2.73	0.18	0.37
30000	1:228600	7.05	4.93	5.64	2.82	0.18	0.35
31000	1:236220	7.28	5.10	5.83	2.91	0.17	0.34
32000	1:243840	7.52	5.26	6.02	3.01	0.17	0.33
33000	1:251460	7.75	5.43	6.20	3.10	0.16	0.32
34000	1:259080	7.99	5.59	6.39	3.20	0.16	0.31
35000	1:266700	8.22	5.76	6.58	3.29	0.15	0.30
36000	1:274320	8.46	5.92	6.77	3.38	0.15	0.30
37000	1:281940	8.69	6.09	6.96	3.48	0.14	0.29
38000	1:289560	8.93	6.25	7.14	3.57	0.14	0.28
39000	1:297180	9.16	6.42	7.33	3.67	0.14	0.27

SCALE AND COVERAGE DATA

Focal Length 3.15 Inches
Format Size 2.25 Inches

HASSELBLAD

Height AGL (Ft)	Photo Scale	Total Cov. (nm)	Line Spac. (nm)	Eff. Forward Coverage		Exposures per nm	
				20%	60%	20%	60%
1000	1: 3810	0.12	0.08	0.09	0.05	10.64	21.28
2000	1: 7620	0.23	0.16	0.19	0.09	5.32	10.64
3000	1: 11430	0.35	0.25	0.28	0.14	3.55	7.09
4000	1: 15240	0.47	0.33	0.38	0.19	2.66	5.32
5000	1: 19050	0.59	0.41	0.47	0.23	2.13	4.26
6000	1: 22860	0.70	0.49	0.56	0.28	1.77	3.55
7000	1: 26670	0.82	0.58	0.66	0.33	1.52	3.04
8000	1: 30480	0.94	0.66	0.75	0.38	1.33	2.66
9000	1: 34290	1.06	0.74	0.85	0.42	1.18	2.36
10000	1: 38100	1.17	0.82	0.94	0.47	1.06	2.13
11000	1: 41910	1.29	0.90	1.03	0.52	0.97	1.93
12000	1: 45720	1.41	0.99	1.13	0.56	0.89	1.77
13000	1: 49530	1.53	1.07	1.22	0.61	0.82	1.64
14000	1: 53340	1.64	1.15	1.32	0.66	0.76	1.52
15000	1: 57150	1.76	1.23	1.41	0.70	0.71	1.42
16000	1: 60960	1.88	1.32	1.50	0.75	0.66	1.33
17000	1: 64770	2.00	1.40	1.60	0.80	0.63	1.25
18000	1: 68580	2.11	1.48	1.69	0.85	0.59	1.18
19000	1: 72390	2.23	1.56	1.79	0.89	0.56	1.12
20000	1: 76200	2.35	1.64	1.88	0.94	0.53	1.06
21000	1: 80010	2.47	1.73	1.97	0.99	0.51	1.01
22000	1: 83820	2.58	1.81	2.07	1.03	0.48	0.97
23000	1: 87630	2.70	1.89	2.16	1.08	0.46	0.93
24000	1: 91440	2.82	1.97	2.26	1.13	0.44	0.89
25000	1: 95250	2.94	2.06	2.35	1.17	0.43	0.85
26000	1: 99060	3.05	2.14	2.44	1.22	0.41	0.82
27000	1:102870	3.17	2.22	2.54	1.27	0.39	0.79
28000	1:106680	3.29	2.30	2.63	1.32	0.38	0.76
29000	1:110490	3.41	2.39	2.73	1.36	0.37	0.73
30000	1:114300	3.52	2.47	2.82	1.41	0.35	0.71
31000	1:118110	3.64	2.55	2.91	1.46	0.34	0.69
32000	1:121920	3.76	2.63	3.01	1.50	0.33	0.66
33000	1:125730	3.88	2.71	3.10	1.55	0.32	0.64
34000	1:129540	3.99	2.80	3.20	1.60	0.31	0.63
35000	1:133350	4.11	2.88	3.29	1.64	0.30	0.61
36000	1:137160	4.23	2.96	3.38	1.69	0.30	0.59
37000	1:140970	4.35	3.04	3.48	1.74	0.29	0.58
38000	1:144780	4.46	3.13	3.57	1.79	0.28	0.56
39000	1:148590	4.58	3.21	3.67	1.83	0.27	0.55

SCALE AND COVERAGE DATA

Focal Length 4.13 Inches HASSELBLAD (U.V.)
 Format Size 2.25 Inches

Height AGL (Ft)	Photo Scale	Total Cov. (nm)	Line Spac. (nm)	Eff. Forward Coverage		Exposures per nm	
				20%	60%	20%	60%
1000	1: 2902	0.09	0.06	0.07	0.04	13.96	27.93
2000	1: 5805	0.18	0.13	0.14	0.07	6.98	13.96
3000	1: 8708	0.27	0.19	0.21	0.11	4.65	9.31
4000	1: 11611	0.36	0.25	0.29	0.14	3.49	6.98
5000	1: 14513	0.45	0.31	0.36	0.18	2.79	5.59
6000	1: 17416	0.54	0.38	0.43	0.21	2.33	4.65
7000	1: 20319	0.63	0.44	0.50	0.25	1.99	3.99
8000	1: 23222	0.72	0.50	0.57	0.29	1.75	3.49
9000	1: 26124	0.81	0.56	0.64	0.32	1.55	3.10
10000	1: 29027	0.90	0.63	0.72	0.36	1.40	2.79
11000	1: 31930	0.98	0.69	0.79	0.39	1.27	2.54
12000	1: 34833	1.07	0.75	0.86	0.43	1.16	2.33
13000	1: 37735	1.16	0.81	0.93	0.47	1.07	2.15
14000	1: 40638	1.25	0.88	1.00	0.50	1.00	1.99
15000	1: 43541	1.34	0.94	1.07	0.54	0.93	1.86
16000	1: 46444	1.43	1.00	1.15	0.57	0.87	1.75
17000	1: 49346	1.52	1.07	1.22	0.61	0.82	1.64
18000	1: 52249	1.61	1.13	1.29	0.64	0.78	1.55
19000	1: 55152	1.70	1.19	1.36	0.68	0.73	1.47
20000	1: 58055	1.79	1.25	1.43	0.72	0.70	1.40
21000	1: 60957	1.88	1.32	1.50	0.75	0.66	1.33
22000	1: 63860	1.97	1.38	1.58	0.79	0.63	1.27
23000	1: 66763	2.06	1.44	1.65	0.82	0.61	1.21
24000	1: 69666	2.15	1.50	1.72	0.86	0.58	1.16
25000	1: 72568	2.24	1.57	1.79	0.90	0.56	1.12
26000	1: 75471	2.33	1.63	1.86	0.93	0.54	1.07
27000	1: 78374	2.42	1.69	1.93	0.97	0.52	1.03
28000	1: 81277	2.51	1.75	2.01	1.00	0.50	1.00
29000	1: 84179	2.60	1.82	2.08	1.04	0.48	0.96
30000	1: 87082	2.69	1.88	2.15	1.07	0.47	0.93
31000	1: 89985	2.78	1.94	2.22	1.11	0.45	0.90
32000	1: 92888	2.86	2.01	2.29	1.15	0.44	0.87
33000	1: 95791	2.95	2.07	2.36	1.18	0.42	0.85
34000	1: 98693	3.04	2.13	2.43	1.22	0.41	0.82
35000	1:101596	3.13	2.19	2.51	1.25	0.40	0.80
36000	1:104499	3.22	2.26	2.58	1.29	0.39	0.78
37000	1:107402	3.31	2.32	2.65	1.32	0.38	0.75
38000	1:110304	3.40	2.38	2.72	1.36	0.37	0.73
39000	1:113207	3.49	2.44	2.79	1.40	0.36	0.72

METRIC SCALE AND COVERAGE DATA

Focal Length 88.00 Millimetres
 Format Size 229.00 Millimetres

RC-10

Height AGL (M)	Photo Scale	Total Cov. (km)	Line Spac. (km)	Eff. Forward Coverage		Exposures per km	
				20%	60%	20%	60%
200	1: 2272	0.52	0.36	0.42	0.21	2.40	4.80
400	1: 4545	1.04	0.73	0.83	0.42	1.20	2.40
600	1: 6818	1.56	1.09	1.25	0.62	0.80	1.60
800	1: 9090	2.08	1.46	1.67	0.83	0.60	1.20
1000	1: 11363	2.60	1.82	2.08	1.04	0.48	0.96
1200	1: 13636	3.12	2.19	2.50	1.25	0.40	0.80
1400	1: 15909	3.64	2.55	2.91	1.46	0.34	0.69
1600	1: 18181	4.16	2.91	3.33	1.67	0.30	0.60
1800	1: 20454	4.68	3.28	3.75	1.87	0.27	0.53
2000	1: 22727	5.20	3.64	4.16	2.08	0.24	0.48
2500	1: 28409	6.51	4.55	5.20	2.60	0.19	0.38
3000	1: 34090	7.81	5.46	6.25	3.12	0.16	0.32
3500	1: 39772	9.11	6.38	7.29	3.64	0.14	0.27
4000	1: 45454	10.41	7.29	8.33	4.16	0.12	0.24
4500	1: 51136	11.71	8.20	9.37	4.68	0.11	0.21
5000	1: 56818	13.01	9.11	10.41	5.20	0.10	0.19
5500	1: 62500	14.31	10.02	11.45	5.72	0.09	0.17
6000	1: 68181	15.61	10.93	12.49	6.25	0.08	0.16
6500	1: 73863	16.91	11.84	13.53	6.77	0.07	0.15
7000	1: 79545	18.22	12.75	14.57	7.29	0.07	0.14
7500	1: 85227	19.52	13.66	15.61	7.81	0.06	0.13
8000	1: 90909	20.82	14.57	16.65	8.33	0.06	0.12
8500	1: 96590	22.12	15.48	17.70	8.85	0.06	0.11
9000	1: 102272	23.42	16.39	18.74	9.37	0.05	0.11
9500	1: 107954	24.72	17.31	19.78	9.89	0.05	0.10
10000	1: 113636	26.02	18.22	20.82	10.41	0.05	0.10
10500	1: 119318	27.32	19.13	21.86	10.93	0.05	0.09
11000	1: 125000	28.63	20.04	22.90	11.45	0.04	0.09
11500	1: 130681	29.93	20.95	23.94	11.97	0.04	0.08
12000	1: 136363	31.23	21.86	24.98	12.49	0.04	0.08
12500	1: 142045	32.53	22.77	26.02	13.01	0.04	0.08
13000	1: 147727	33.83	23.68	27.06	13.53	0.04	0.07
13500	1: 153409	35.13	24.59	28.10	14.05	0.04	0.07
14000	1: 159090	36.43	25.50	29.15	14.57	0.03	0.07
14500	1: 164772	37.73	26.41	30.19	15.09	0.03	0.07
15000	1: 170454	39.03	27.32	31.23	15.61	0.03	0.06
15500	1: 176136	40.34	28.23	32.27	16.13	0.03	0.06
16000	1: 181818	41.64	29.15	33.31	16.65	0.03	0.06
16500	1: 187500	42.94	30.06	34.35	17.17	0.03	0.06

METRIC SCALE AND COVERAGE DATA

Focal Length 152.00 Millimetres RC-8
 Format Size 229.00 Millimetres RC-10

Height AGL (M)	Photo Scale	Total Cov. (km)	Line Spac. (km)	Eff. Forward Coverage		Exposures per km	
				20%	60%	20%	60%
200	1: 1315	0.30	0.21	0.24	0.12	4.15	8.30
400	1: 2631	0.60	0.42	0.48	0.24	2.07	4.15
600	1: 3947	0.90	0.63	0.72	0.36	1.38	2.77
800	1: 5263	1.21	0.84	0.96	0.48	1.04	2.07
1000	1: 6578	1.51	1.05	1.21	0.60	0.83	1.66
1200	1: 7894	1.81	1.27	1.45	0.72	0.69	1.38
1400	1: 9210	2.11	1.48	1.69	0.84	0.59	1.19
1600	1: 10526	2.41	1.69	1.93	0.96	0.52	1.04
1800	1: 11842	2.71	1.90	2.17	1.08	0.46	0.92
2000	1: 13157	3.01	2.11	2.41	1.21	0.41	0.83
2500	1: 16447	3.77	2.64	3.01	1.51	0.33	0.66
3000	1: 19736	4.52	3.16	3.62	1.81	0.28	0.55
3500	1: 23026	5.27	3.69	4.22	2.11	0.24	0.47
4000	1: 26315	6.03	4.22	4.82	2.41	0.21	0.41
4500	1: 29605	6.78	4.75	5.42	2.71	0.18	0.37
5000	1: 32894	7.53	5.27	6.03	3.01	0.17	0.33
5500	1: 36184	8.29	5.80	6.63	3.31	0.15	0.30
6000	1: 39473	9.04	6.33	7.23	3.62	0.14	0.28
6500	1: 42763	9.79	6.85	7.83	3.92	0.13	0.26
7000	1: 46052	10.55	7.38	8.44	4.22	0.12	0.24
7500	1: 49342	11.30	7.91	9.04	4.52	0.11	0.22
8000	1: 52631	12.05	8.44	9.64	4.82	0.10	0.21
8500	1: 55921	12.81	8.96	10.24	5.12	0.10	0.20
9000	1: 59210	13.56	9.49	10.85	5.42	0.09	0.18
9500	1: 62500	14.31	10.02	11.45	5.72	0.09	0.17
10000	1: 65789	15.07	10.55	12.05	6.03	0.08	0.17
10500	1: 69078	15.82	11.07	12.66	6.33	0.08	0.16
11000	1: 72368	16.57	11.60	13.26	6.63	0.08	0.15
11500	1: 75657	17.33	12.13	13.86	6.93	0.07	0.14
12000	1: 78947	18.08	12.66	14.46	7.23	0.07	0.14
12500	1: 82236	18.83	13.18	15.07	7.53	0.07	0.13
13000	1: 85526	19.59	13.71	15.67	7.83	0.06	0.13
13500	1: 88815	20.34	14.24	16.27	8.14	0.06	0.12
14000	1: 92105	21.09	14.76	16.87	8.44	0.06	0.12
14500	1: 95394	21.85	15.29	17.48	8.74	0.06	0.11
15000	1: 98684	22.60	15.82	18.08	9.04	0.06	0.11
15500	1:101973	23.35	16.35	18.68	9.34	0.05	0.11
16000	1:105263	24.11	16.87	19.28	9.64	0.05	0.10
16500	1:108552	24.86	17.40	19.89	9.94	0.05	0.10

METRIC SCALE AND COVERAGE DATA

Focal Length 38.00 Millimetres VINTEN
 Format Size 57.00 Millimetres

Height AGL (M)	Photo Scale	Total Cov. (km)	Line Spac. (km)	Eff. Forward Coverage		Exposures per km	
				20%	60%	20%	60%
200	1: 5263	0.30	0.21	0.24	0.12	4.17	8.33
400	1: 10526	0.60	0.42	0.48	0.24	2.08	4.17
600	1: 15789	0.90	0.63	0.72	0.36	1.39	2.78
800	1: 21052	1.20	0.84	0.96	0.48	1.04	2.08
1000	1: 26315	1.50	1.05	1.20	0.60	0.83	1.67
1200	1: 31578	1.80	1.26	1.44	0.72	0.69	1.39
1400	1: 36842	2.10	1.47	1.68	0.84	0.60	1.19
1600	1: 42105	2.40	1.68	1.92	0.96	0.52	1.04
1800	1: 47368	2.70	1.89	2.16	1.08	0.46	0.93
2000	1: 52631	3.00	2.10	2.40	1.20	0.42	0.83
2500	1: 65789	3.75	2.63	3.00	1.50	0.33	0.67
3000	1: 78947	4.50	3.15	3.60	1.80	0.28	0.56
3500	1: 92105	5.25	3.68	4.20	2.10	0.24	0.48
4000	1:105263	6.00	4.20	4.80	2.40	0.21	0.42
4500	1:118421	6.75	4.73	5.40	2.70	0.19	0.37
5000	1:131578	7.50	5.25	6.00	3.00	0.17	0.33
5500	1:144736	8.25	5.78	6.60	3.30	0.15	0.30
6000	1:157894	9.00	6.30	7.20	3.60	0.14	0.28
6500	1:171052	9.75	6.83	7.80	3.90	0.13	0.26
7000	1:184210	10.50	7.35	8.40	4.20	0.12	0.24
7500	1:197368	11.25	7.88	9.00	4.50	0.11	0.22
8000	1:210526	12.00	8.40	9.60	4.80	0.10	0.21
8500	1:223684	12.75	8.93	10.20	5.10	0.10	0.20
9000	1:236842	13.50	9.45	10.80	5.40	0.09	0.19
9500	1:250000	14.25	9.98	11.40	5.70	0.09	0.18
10000	1:263157	15.00	10.50	12.00	6.00	0.08	0.17
10500	1:276315	15.75	11.03	12.60	6.30	0.08	0.16
11000	1:289473	16.50	11.55	13.20	6.60	0.08	0.15
11500	1:302631	17.25	12.08	13.80	6.90	0.07	0.14
12000	1:315789	18.00	12.60	14.40	7.20	0.07	0.14
12500	1:328947	18.75	13.13	15.00	7.50	0.07	0.13
13000	1:342105	19.50	13.65	15.60	7.80	0.06	0.13
13500	1:355263	20.25	14.18	16.20	8.10	0.06	0.12
14000	1:368421	21.00	14.70	16.80	8.40	0.06	0.12
14500	1:381578	21.75	15.23	17.40	8.70	0.06	0.11
15000	1:394736	22.50	15.75	18.00	9.00	0.06	0.11
15500	1:407894	23.25	16.28	18.60	9.30	0.05	0.11
16000	1:421052	24.00	16.80	19.20	9.60	0.05	0.10
16500	1:434210	24.75	17.33	19.80	9.90	0.05	0.10

METRIC SCALE AND COVERAGE DATA

Focal Length 76.00 Millimetres
 Format Size 57.00 Millimetres

VINTEN

Height AGL (M)	Photo Scale	Total Cov. (km)	Line Spac. (km)	Eff. Forward Coverage		Exposures per km	
				20%	60%	20%	60%
200	1: 2631	0.15	0.11	0.12	0.06	8.33	16.67
400	1: 5263	0.30	0.21	0.24	0.12	4.17	8.33
600	1: 7894	0.45	0.32	0.36	0.18	2.78	5.56
800	1: 10526	0.60	0.42	0.48	0.24	2.08	4.17
1000	1: 13157	0.75	0.53	0.60	0.30	1.67	3.33
1200	1: 15789	0.90	0.63	0.72	0.36	1.39	2.78
1400	1: 18421	1.05	0.73	0.84	0.42	1.19	2.38
1600	1: 21052	1.20	0.84	0.96	0.48	1.04	2.08
1800	1: 23684	1.35	0.95	1.08	0.54	0.93	1.85
2000	1: 26315	1.50	1.05	1.20	0.60	0.83	1.67
2500	1: 32894	1.88	1.31	1.50	0.75	0.67	1.33
3000	1: 39473	2.25	1.58	1.80	0.90	0.56	1.11
3500	1: 46052	2.63	1.84	2.10	1.05	0.48	0.95
4000	1: 52631	3.00	2.10	2.40	1.20	0.42	0.83
4500	1: 59210	3.38	2.36	2.70	1.35	0.37	0.74
5000	1: 65789	3.75	2.63	3.00	1.50	0.33	0.67
5500	1: 72368	4.13	2.89	3.30	1.65	0.30	0.61
6000	1: 78947	4.50	3.15	3.60	1.80	0.28	0.56
6500	1: 85526	4.88	3.41	3.90	1.95	0.26	0.51
7000	1: 92105	5.25	3.68	4.20	2.10	0.24	0.48
7500	1: 98684	5.63	3.94	4.50	2.25	0.22	0.44
8000	1:105263	6.00	4.20	4.80	2.40	0.21	0.42
8500	1:111842	6.38	4.46	5.10	2.55	0.20	0.39
9000	1:118421	6.75	4.73	5.40	2.70	0.19	0.37
9500	1:125000	7.13	4.99	5.70	2.85	0.18	0.35
10000	1:131578	7.50	5.25	6.00	3.00	0.17	0.33
10500	1:138157	7.88	5.51	6.30	3.15	0.16	0.32
11000	1:144736	8.25	5.78	6.60	3.30	0.15	0.30
11500	1:151315	8.63	6.04	6.90	3.45	0.14	0.29
12000	1:157894	9.00	6.30	7.20	3.60	0.14	0.28
12500	1:164473	9.38	6.56	7.50	3.75	0.13	0.27
13000	1:171052	9.75	6.83	7.80	3.90	0.13	0.26
13500	1:177631	10.13	7.09	8.10	4.05	0.12	0.25
14000	1:184210	10.50	7.35	8.40	4.20	0.12	0.24
14500	1:190789	10.88	7.61	8.70	4.35	0.11	0.23
15000	1:197368	11.25	7.88	9.00	4.50	0.11	0.22
15500	1:203947	11.63	8.14	9.30	4.65	0.11	0.22
16000	1:210526	12.00	8.40	9.60	4.80	0.10	0.21
16500	1:217105	12.38	8.66	9.90	4.95	0.10	0.20

METRIC SCALE AND COVERAGE DATA

Focal Length 152.00 Millimetres
 Format Size 57.00 Millimetres

VINTEN

Height AGL (M)	Photo Scale	Total Cov. (km)	Line Spac. (km)	Eff. Forward Coverage		Exposures per km	
				20%	60%	20%	60%
200	1: 1315	0.08	0.05	0.06	0.03	16.67	33.33
400	1: 2631	0.15	0.11	0.12	0.06	8.33	16.67
600	1: 3947	0.22	0.16	0.18	0.09	5.56	11.11
800	1: 5263	0.30	0.21	0.24	0.12	4.17	8.33
1000	1: 6578	0.38	0.26	0.30	0.15	3.33	6.67
1200	1: 7894	0.45	0.32	0.36	0.18	2.78	5.56
1400	1: 9210	0.52	0.37	0.42	0.21	2.38	4.76
1600	1: 10526	0.60	0.42	0.48	0.24	2.08	4.17
1800	1: 11842	0.67	0.47	0.54	0.27	1.85	3.70
2000	1: 13157	0.75	0.53	0.60	0.30	1.67	3.33
2500	1: 16447	0.94	0.66	0.75	0.38	1.33	2.67
3000	1: 19736	1.13	0.79	0.90	0.45	1.11	2.22
3500	1: 23026	1.31	0.92	1.05	0.52	0.95	1.90
4000	1: 26315	1.50	1.05	1.20	0.60	0.83	1.67
4500	1: 29605	1.69	1.18	1.35	0.67	0.74	1.48
5000	1: 32894	1.88	1.31	1.50	0.75	0.67	1.33
5500	1: 36184	2.06	1.44	1.65	0.82	0.61	1.21
6000	1: 39473	2.25	1.58	1.80	0.90	0.56	1.11
6500	1: 42763	2.44	1.71	1.95	0.97	0.51	1.03
7000	1: 46052	2.63	1.84	2.10	1.05	0.48	0.95
7500	1: 49342	2.81	1.97	2.25	1.13	0.44	0.89
8000	1: 52631	3.00	2.10	2.40	1.20	0.42	0.83
8500	1: 55921	3.19	2.23	2.55	1.27	0.39	0.78
9000	1: 59210	3.38	2.36	2.70	1.35	0.37	0.74
9500	1: 62500	3.56	2.49	2.85	1.42	0.35	0.70
10000	1: 65789	3.75	2.63	3.00	1.50	0.33	0.67
10500	1: 69078	3.94	2.76	3.15	1.57	0.32	0.63
11000	1: 72368	4.13	2.89	3.30	1.65	0.30	0.61
11500	1: 75657	4.31	3.02	3.45	1.72	0.29	0.58
12000	1: 78947	4.50	3.15	3.60	1.80	0.28	0.56
12500	1: 82236	4.69	3.28	3.75	1.88	0.27	0.53
13000	1: 85526	4.88	3.41	3.90	1.95	0.26	0.51
13500	1: 88815	5.06	3.54	4.05	2.03	0.25	0.49
14000	1: 92105	5.25	3.68	4.20	2.10	0.24	0.48
14500	1: 95394	5.44	3.81	4.35	2.17	0.23	0.46
15000	1: 98684	5.63	3.94	4.50	2.25	0.22	0.44
15500	1:101973	5.81	4.07	4.65	2.32	0.22	0.43
16000	1:105263	6.00	4.20	4.80	2.40	0.21	0.42
16500	1:108552	6.19	4.33	4.95	2.47	0.20	0.40

METRIC SCALE AND COVERAGE DATA

Focal Length 40.00 Millimetres HASSELBLAD
 Format Size 57.00 Millimetres

Height AGL (M)	Photo Scale	Total Cov. (km)	Line Spac. (km)	Eff. Forward Coverage		Exposures per km	
				20%	60%	20%	60%
200	1: 5000	0.29	0.20	0.23	0.11	4.39	8.77
400	1: 10000	0.57	0.40	0.46	0.23	2.19	4.39
600	1: 15000	0.85	0.60	0.68	0.34	1.46	2.92
800	1: 20000	1.14	0.80	0.91	0.46	1.10	2.19
1000	1: 25000	1.42	1.00	1.14	0.57	0.88	1.75
1200	1: 30000	1.71	1.20	1.37	0.68	0.73	1.46
1400	1: 35000	2.00	1.40	1.60	0.80	0.63	1.25
1600	1: 40000	2.28	1.60	1.82	0.91	0.55	1.10
1800	1: 45000	2.56	1.80	2.05	1.03	0.49	0.97
2000	1: 50000	2.85	2.00	2.28	1.14	0.44	0.88
2500	1: 62500	3.56	2.49	2.85	1.42	0.35	0.70
3000	1: 75000	4.27	2.99	3.42	1.71	0.29	0.58
3500	1: 87500	4.99	3.49	3.99	2.00	0.25	0.50
4000	1:100000	5.70	3.99	4.56	2.28	0.22	0.44
4500	1:112500	6.41	4.49	5.13	2.56	0.19	0.39
5000	1:125000	7.13	4.99	5.70	2.85	0.18	0.35
5500	1:137500	7.84	5.49	6.27	3.13	0.16	0.32
6000	1:150000	8.55	5.99	6.84	3.42	0.15	0.29
6500	1:162500	9.26	6.48	7.41	3.71	0.13	0.27
7000	1:175000	9.98	6.98	7.98	3.99	0.13	0.25
7500	1:187500	10.69	7.48	8.55	4.27	0.12	0.23
8000	1:200000	11.40	7.98	9.12	4.56	0.11	0.22
8500	1:212500	12.11	8.48	9.69	4.84	0.10	0.21
9000	1:225000	12.83	8.98	10.26	5.13	0.10	0.19
9500	1:237500	13.54	9.48	10.83	5.41	0.09	0.18
10000	1:250000	14.25	9.98	11.40	5.70	0.09	0.18
10500	1:262500	14.96	10.47	11.97	5.98	0.08	0.17
11000	1:275000	15.67	10.97	12.54	6.27	0.08	0.16
11500	1:287500	16.39	11.47	13.11	6.56	0.08	0.15
12000	1:300000	17.10	11.97	13.68	6.84	0.07	0.15
12500	1:312500	17.81	12.47	14.25	7.13	0.07	0.14
13000	1:325000	18.53	12.97	14.82	7.41	0.07	0.13
13500	1:337500	19.24	13.47	15.39	7.69	0.06	0.13
14000	1:350000	19.95	13.97	15.96	7.98	0.06	0.13
14500	1:362500	20.66	14.46	16.53	8.26	0.06	0.12
15000	1:375000	21.38	14.96	17.10	8.55	0.06	0.12
15500	1:387500	22.09	15.46	17.67	8.84	0.06	0.11
16000	1:400000	22.80	15.96	18.24	9.12	0.05	0.11
16500	1:412500	23.51	16.46	18.81	9.40	0.05	0.11

METRIC SCALE AND COVERAGE DATA

Focal Length 80.00 Millimetres HASSELBLAD
 Format Size 57.00 Millimetres

Height AGL (M)	Photo Scale	Total Cov. (km)	Line Spac. (km)	Eff. Forward Coverage		Exposures per km	
				20%	60%	20%	60%
200	1: 2500	0.14	0.10	0.11	0.06	8.77	17.54
400	1: 5000	0.29	0.20	0.23	0.11	4.39	8.77
600	1: 7500	0.43	0.30	0.34	0.17	2.92	5.85
800	1: 10000	0.57	0.40	0.46	0.23	2.19	4.39
1000	1: 12500	0.71	0.50	0.57	0.29	1.75	3.51
1200	1: 15000	0.85	0.60	0.68	0.34	1.46	2.92
1400	1: 17500	1.00	0.70	0.80	0.40	1.25	2.51
1600	1: 20000	1.14	0.80	0.91	0.46	1.10	2.19
1800	1: 22500	1.28	0.90	1.03	0.51	0.97	1.95
2000	1: 25000	1.42	1.00	1.14	0.57	0.88	1.75
2500	1: 31250	1.78	1.25	1.42	0.71	0.70	1.40
3000	1: 37500	2.14	1.50	1.71	0.85	0.58	1.17
3500	1: 43750	2.49	1.75	2.00	1.00	0.50	1.00
4000	1: 50000	2.85	2.00	2.28	1.14	0.44	0.88
4500	1: 56250	3.21	2.24	2.56	1.28	0.39	0.78
5000	1: 62500	3.56	2.49	2.85	1.42	0.35	0.70
5500	1: 68750	3.92	2.74	3.13	1.57	0.32	0.64
6000	1: 75000	4.27	2.99	3.42	1.71	0.29	0.58
6500	1: 81250	4.63	3.24	3.71	1.85	0.27	0.54
7000	1: 87500	4.99	3.49	3.99	2.00	0.25	0.50
7500	1: 93750	5.34	3.74	4.27	2.14	0.23	0.47
8000	1:100000	5.70	3.99	4.56	2.28	0.22	0.44
8500	1:106250	6.06	4.24	4.84	2.42	0.21	0.41
9000	1:112500	6.41	4.49	5.13	2.56	0.19	0.39
9500	1:118750	6.77	4.74	5.41	2.71	0.18	0.37
10000	1:125000	7.13	4.99	5.70	2.85	0.18	0.35
10500	1:131250	7.48	5.24	5.98	2.99	0.17	0.33
11000	1:137500	7.84	5.49	6.27	3.13	0.16	0.32
11500	1:143750	8.19	5.74	6.56	3.28	0.15	0.31
12000	1:150000	8.55	5.99	6.84	3.42	0.15	0.29
12500	1:156250	8.91	6.23	7.13	3.56	0.14	0.28
13000	1:162500	9.26	6.48	7.41	3.71	0.13	0.27
13500	1:168750	9.62	6.73	7.69	3.85	0.13	0.26
14000	1:175000	9.98	6.98	7.98	3.99	0.13	0.25
14500	1:181250	10.33	7.23	8.26	4.13	0.12	0.24
15000	1:187500	10.69	7.48	8.55	4.27	0.12	0.23
15500	1:193750	11.04	7.73	8.84	4.42	0.11	0.23
16000	1:200000	11.40	7.98	9.12	4.56	0.11	0.22
16500	1:206250	11.76	8.23	9.40	4.70	0.11	0.21

METRIC SCALE AND COVERAGE DATA

Focal Length 105.00 Millimetres
 Format Size 57.00 Millimetres

HASSELBLAD (U.V.)

Height AGL (M)	Photo Scale	Total Cov. (km)	Line Spac. (km)	Eff. Forward Coverage		Exposures per km	
				20%	60%	20%	60%
200	1: 1904	0.11	0.08	0.09	0.04	11.51	23.03
400	1: 3809	0.22	0.15	0.17	0.09	5.76	11.51
600	1: 5714	0.33	0.23	0.26	0.13	3.84	7.68
800	1: 7619	0.43	0.30	0.35	0.17	2.88	5.76
1000	1: 9523	0.54	0.38	0.43	0.22	2.30	4.61
1200	1: 11428	0.65	0.46	0.52	0.26	1.92	3.84
1400	1: 13333	0.76	0.53	0.61	0.30	1.64	3.29
1600	1: 15238	0.87	0.61	0.69	0.35	1.44	2.88
1800	1: 17142	0.98	0.68	0.78	0.39	1.28	2.56
2000	1: 19047	1.09	0.76	0.87	0.43	1.15	2.30
2500	1: 23809	1.36	0.95	1.09	0.54	0.92	1.84
3000	1: 28571	1.63	1.14	1.30	0.65	0.77	1.54
3500	1: 33333	1.90	1.33	1.52	0.76	0.66	1.32
4000	1: 38095	2.17	1.52	1.74	0.87	0.58	1.15
4500	1: 42857	2.44	1.71	1.95	0.98	0.51	1.02
5000	1: 47619	2.71	1.90	2.17	1.09	0.46	0.92
5500	1: 52380	2.99	2.09	2.39	1.19	0.42	0.84
6000	1: 57142	3.26	2.28	2.61	1.30	0.38	0.77
6500	1: 61904	3.53	2.47	2.82	1.41	0.35	0.71
7000	1: 66666	3.80	2.66	3.04	1.52	0.33	0.66
7500	1: 71428	4.07	2.85	3.26	1.63	0.31	0.61
8000	1: 76190	4.34	3.04	3.47	1.74	0.29	0.58
8500	1: 80952	4.61	3.23	3.69	1.85	0.27	0.54
9000	1: 85714	4.89	3.42	3.91	1.95	0.26	0.51
9500	1: 90476	5.16	3.61	4.13	2.06	0.24	0.48
10000	1: 95238	5.43	3.80	4.34	2.17	0.23	0.46
10500	1:100000	5.70	3.99	4.56	2.28	0.22	0.44
11000	1:104761	5.97	4.18	4.78	2.39	0.21	0.42
11500	1:109523	6.24	4.37	4.99	2.50	0.20	0.40
12000	1:114285	6.51	4.56	5.21	2.61	0.19	0.38
12500	1:119047	6.79	4.75	5.43	2.71	0.18	0.37
13000	1:123809	7.06	4.94	5.65	2.82	0.18	0.35
13500	1:128571	7.33	5.13	5.86	2.93	0.17	0.34
14000	1:133333	7.60	5.32	6.08	3.04	0.16	0.33
14500	1:138095	7.87	5.51	6.30	3.15	0.16	0.32
15000	1:142857	8.14	5.70	6.51	3.26	0.15	0.31
15500	1:147619	8.41	5.89	6.73	3.37	0.15	0.30
16000	1:152380	8.69	6.08	6.95	3.47	0.14	0.29
16500	1:157142	8.96	6.27	7.17	3.58	0.14	0.28

LINE SCANNER COVERAGE

Scan Angle 77.2 Degrees

Height AGL (Ft)	Total Coverage		Line Spacing		Film per NM (Ft)	Approx. Scale	
	(Ft)	(NM)	(Ft)	(NM)		5 in. Format	70 mm Format
1000	1596	0.26	1117	0.18	1.666	1: 3649	1: 7298
2000	3193	0.53	2235	0.37	.833	1: 7298	1: 14596
3000	4789	0.79	3352	0.55	.555	1: 10947	1: 21894
4000	6386	1.05	4470	0.74	.417	1: 14597	1: 29194
5000	7982	1.31	5588	0.92	.333	1: 18246	1: 36492
6000	9579	1.58	6705	1.10	.278	1: 21895	1: 43790
7000	11176	1.84	7823	1.29	.238	1: 25545	1: 51090
8000	12772	2.10	8940	1.47	.208	1: 29194	1: 58388
9000	14369	2.36	10058	1.65	.185	1: 32843	1: 65686
10000	15965	2.63	11176	1.84	.167	1: 36493	1: 72986
11000	17562	2.89	12293	2.02	.151	1: 40142	1: 80284
12000	19158	3.15	13411	2.21	.139	1: 43791	1: 87582
13000	20755	3.41	14528	2.39	.128	1: 47441	1: 94882
14000	22352	3.68	15646	2.57	.119	1: 51090	1: 102180
15000	23948	3.94	16764	2.76	.111	1: 54739	1: 109478
16000	25545	4.20	17881	2.94	.104	1: 58389	1: 116778
17000	27141	4.46	18999	3.12	.098	1: 62038	1: 124076
18000	28738	4.73	20116	3.31	.093	1: 65687	1: 131374
19000	30335	4.99	21234	3.49	.088	1: 69337	1: 138674
20000	31931	5.25	22352	3.68	.083	1: 72986	1: 145972
21000	33528	5.51	23469	3.86	.079	1: 76635	1: 153270
22000	35124	5.78	24587	4.04	.076	1: 80285	1: 160570
23000	36721	6.04	25704	4.23	.072	1: 83934	1: 167868
24000	38317	6.30	26822	4.41	.069	1: 87583	1: 175166
25000	39914	6.56	27940	4.60	.067	1: 91233	1: 182466
26000	41511	6.83	29057	4.78	.064	1: 94882	1: 189764
27000	43107	7.09	30175	4.96	.062	1: 98531	1: 197062
28000	44704	7.35	31292	5.15	.060	1: 102181	1: 204362
29000	46300	7.62	32410	5.33	.057	1: 105830	1: 211660
30000	47897	7.88	33528	5.51	.056	1: 109479	1: 218958
31000	49493	8.14	34645	5.70	.054	1: 113129	1: 226258
32000	51090	8.40	35763	5.88	.052	1: 116778	1: 233556
33000	52687	8.67	36880	6.07	.050	1: 120427	1: 240854
34000	54283	8.93	37998	6.25	.049	1: 124076	1: 248152
35000	55880	9.19	39116	6.43	.048	1: 127726	1: 255452
36000	57476	9.45	40233	6.62	.046	1: 131375	1: 262750
37000	59073	9.72	41351	6.80	.045	1: 135024	1: 270048
38000	60670	9.98	42469	6.99	.044	1: 138674	1: 277347
39000	62266	10.24	43586	7.17	.042	1: 142323	1: 284646

METRIC LINE SCANNER COVERAGE

Scan Angle 77.2 Degrees

Height AGL (M)	Total Coverage		Line Spacing		Film per Km (M)	Approx. Scale	
	(M)	(Km)	(M)	(Km)		5 in. Format	70 mm Format
200	319	0.32	223	0.22	1.370	1: 2394	1: 4788
400	638	0.64	447	0.45	.685	1: 4789	1: 9578
600	957	0.96	670	0.67	.457	1: 7183	1: 14366
800	1277	1.28	894	0.89	.343	1: 9578	1: 19156
1000	1596	1.60	1117	1.12	.274	1: 11972	1: 23944
1200	1915	1.92	1341	1.34	.228	1: 14367	1: 28734
1400	2235	2.24	1564	1.56	.196	1: 16761	1: 33522
1600	2554	2.55	1788	1.79	.171	1: 19156	1: 38312
1800	2873	2.87	2011	2.01	.152	1: 21551	1: 43102
2000	3193	3.19	2235	2.24	.137	1: 23945	1: 47890
2500	3991	3.99	2794	2.79	.110	1: 29932	1: 59864
3000	4789	4.79	3352	3.35	.091	1: 35918	1: 71836
3500	5588	5.59	3911	3.91	.078	1: 41904	1: 83808
4000	6386	6.39	4470	4.47	.069	1: 47891	1: 95782
4500	7184	7.18	5029	5.03	.061	1: 53877	1:107754
5000	7982	7.98	5588	5.59	.055	1: 59864	1:119728
5500	8781	8.78	6146	6.15	.050	1: 65850	1:131700
6000	9579	9.58	6705	6.71	.046	1: 71836	1:143672
6500	10377	10.38	7264	7.26	.042	1: 77823	1:155646
7000	11176	11.18	7823	7.82	.039	1: 83809	1:167618
7500	11974	11.97	8382	8.38	.037	1: 89796	1:179592
8000	12772	12.77	8940	8.94	.034	1: 95782	1:191564
8500	13570	13.57	9499	9.50	.032	1:101768	1:203536
9000	14369	14.37	10058	10.06	.030	1:107755	1:215510
9500	15167	15.17	10617	10.62	.029	1:113741	1:227482
10000	15965	15.97	11176	11.18	.027	1:119728	1:239456
10500	16764	16.76	11734	11.73	.026	1:125714	1:251428
11000	17562	17.56	12293	12.29	.025	1:131701	1:263402
11500	18360	18.36	12852	12.85	.024	1:137687	1:275374
12000	19158	19.16	13411	13.41	.023	1:143673	1:287346
12500	19957	19.96	13970	13.97	.022	1:149660	1:299320
13000	20755	20.76	14528	14.53	.021	1:155646	1:311292
13500	21553	21.55	15087	15.09	.020	1:161633	1:323266
14000	22352	22.35	15646	15.65	.020	1:167619	1:335238
14500	23150	23.15	16205	16.21	.019	1:173605	1:347210
15000	23948	23.95	16764	16.76	.018	1:179592	1:359184
15500	24746	24.75	17322	17.32	.017	1:185578	1:371157
16000	25545	25.55	17881	17.88	.017	1:191565	1:383130
16500	26343	26.34	18440	18.44	.016	1:197551	1:395102

APPENDIX C

SUPER-WIDE ANGLE CAMERAS - PRO AND CON

C.1 INTRODUCTION

In seeking to expand the applications of very small scale aerial photography, and to familiarize potential users of ERTS satellite data with small scale imagery, CCRS operates an airborne program of multispectral data acquisition which includes use of super-wide angle air survey cameras of approximately 3.5 inches (85-88mm) focal length covering a 9" X 9" (23 cm X 23 cm) format. These cameras have a total field of view of about 120 degrees across the diagonal, and make it possible for us to secure extensive photography at scales smaller than 1:125,000 from operating altitudes up to 40,000 feet.

The obvious advantages of super-wide angle photography must be purchased at a price in terms of operating limitations. The extremely wide field of view is accompanied by off-axis illumination fall-off which results in the corners of the photographs receiving much less light than the centre. Although we cannot pump more image-forming light into the corners, we can minimize the effect of lens fall-off by using an anti-vignetting filter which attenuates the axial illumination without restricting the illumination of the corners. To this end we have acquired a special minus-blue filter with an unusually heavy anti-vignetting coating having an effective filter factor on axis of 3.3X. With this filter in place the illumination differences are reduced to the point where the corners of the format receive about 50 percent of the illuminance available on the axis, compared to less than 20 percent with no filter.

In photographers' terms, even with the heavy anti-vignetting filter in place, there is still a full stop difference of exposure between the centre and the corners of the format. When using black and white panchromatic negative films which afford considerable exposure latitude the resulting density variations can be readily compensated by dodging at the printing stage.

C.2 INFRARED COLOUR FILM

Kodak Aerochrome Infrared Film, type 2443, has proven to be one of the most interesting and potentially useful photographic materials currently available to users of aerial photography in a wide range of disciplines. Its high contrast, false colour rendition secures good colour differentiation between objects of similar brightness but different spectral reflectance which might be difficult to separate in a monochrome (black and white) rendition; its near infrared sensitivity makes it particularly useful to foresters, plant pathologists and bio-scientists generally in assessing the distribution of disease, insect infestation, moisture stress or other factors affecting the vigour of vegetative cover; and the fact that it is always used in conjunction with a minus-blue filter means that the image suffers less degradation from scattering, non-image-forming, short-wavelength radiation than normal colour photography when used at very high altitudes.

The virtues of colour infrared film must also be purchased at a price measured not only in dollars*. It has less than half the effective film speed of other commonly used aerial films, and being a reversal** material, its exposure latitude is limited. It follows that, for optimum results, colour infrared film should be used only in a

*Colour infrared film costs about 60 percent more than ordinary colour film and a whole order of magnitude more than black and white film.

**A reversal material is one in which a positive image is formed in the original film. (e.g. 35 mm colour slides)

camera whose lens distributes illumination evenly over the focal plane, and the correct camera exposure must be determined within narrow limits.

C.3 CASCADING LIMITATIONS, OR 2+2≠4

Inevitably, many investigators have asked us to use the colour infrared film in the super-wide angle camera in order to realize the obvious advantages of both. Like all marriages between outstanding individuals, this union is fraught with pitfalls, and the offspring tend to exacerbate the genetic defects of both progenitors, rather than enhance their virtues. The resulting photographs may prove disappointing to investigators whose expectations may have been shaped by having seen impressive infrared colour photographs that did not originate in a SWA camera.

The accompanying diagrams (Figure 28) are an attempt to illustrate the situation graphically. The central set of curves (A) has been plotted from measurements made on the sensitometric step-wedge printed as a routine quality control measure on a typical roll of CCRS colour infrared film. Densities were measured with a controlled photo-electric densitometer fitted with Status A red (R), green (G), blue (B) and visual (N) (Wratten #106) filters.

C.4 CHARACTERISTICS OF THE ORIGINAL FILM

The high contrast characteristic of this material is evident from the steep slope of the curves whose average gradient exceeds a value of 2.0. The subject brightness range which can be accommodated without undue distortion of relative tone or colour values is about 10:1. This correlates well with the range likely to be encountered in high altitude photography if we exclude such extreme cases as glaciated, forested mountains. However this range can be accommodated at only one optimum level of exposure. More exposure would result in loss of highlight details (H) in the toe (lower portion) of the curves; less exposure would lose information in the darker portions (S) of the scene by moving them farther around on the shoulder of the curves.

The foregoing paragraph assumes no modification of apparent brightness across the focal plane due to vignetting by the lens or to other effects external to the camera. In photographers' terms, for a subject of 10:1 brightness range there is no exposure latitude.

If the same scene is photographed with a super-wide angle camera in which the focal plane illumination is subject to vignetting, the effective brightness range as "seen" by the film is extended so that the brightest areas may be "washed out" by over-exposure near the centre while the darkest areas are "blocked" by under-exposure in the corners. On the illustration, the total effect of vignetting equivalent to one full stop has been arbitrarily split, with one half applied to the highlight end of the brightness range and the other half applied to the shadow end. This is tantamount to adjusting the camera exposure to a compromise level whereby the corners are not grossly under-exposed and the centre not grossly over-exposed, while a maximum near-circular area of the field receives near optimum exposure on the straight-line portion of the characteristic curves.

C.5 CHARACTERISTICS OF REPRODUCTIONS

When the original film is reproduced, either as a transparency viewed by transmitted light on a light-table or projected on a screen, or as a paper print viewed by reflected light, further distortions of apparent relative brightness and colour occur. To examine the qualitative nature of these distortions, two reversal colour prints were made from the original film, one on transparent colour copy film and one on colour paper.

Since the printing process is one in which the original image modulates the input to the print, the process is represented graphically by projecting points on the original curves (A) to the resulting density levels of corresponding points in the reproductive graphs (B & C). The density axis of the original becomes the relative log exposure axis of the reproduction. It is apparent that the two reproductions are quite different from each other, and that both differ from the original, the differences arising from the

non-linearity of the various characteristic curves.

The transparent reproduction records the full range of useful densities present in the original film, but the relative amounts of the different colours (colour balance) is altered. The balance may be re-adjusted by the use of correction filters in printers but an exact restoration is extremely elusive.

The limited dynamic range of the reflection print is incapable of reproducing the full range of densities of the original transparency. This circumstance is due in part to the fact that the light by which one perceives a reflection print must pass twice through the emulsion layers and be reflected from the base before being received by the eye or measured by a reflection densitometer.

C.6 SUMMARY

The combination of the super-wide angle camera and colour infrared reversal film is undoubtedly useful for qualitative examination over a broad area of a number of phenomena of considerable economic significance. But quantitative determinations involving colorimetry, density-slicing, or other techniques which assume that a given tone or colour will bear a unique significance regardless of its position in the field of view or on the scale of brightness, should either employ other sensors or be supplemented by complex correction programs assuming a knowledge of parameters which will be difficult to evaluate. And the further one is removed from the original, the more questionable are the results.

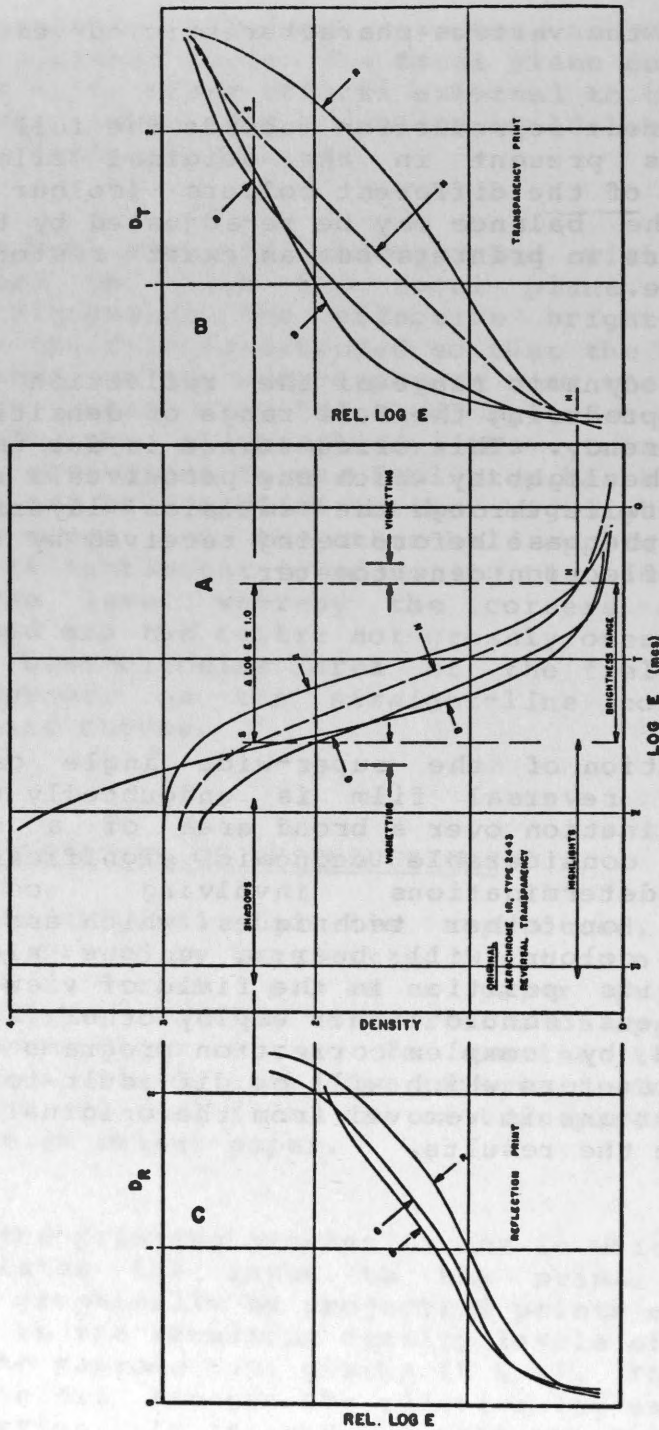

Figure 28 -- 2443 - Characteristic Curves

APPENDIX D

IMAGE MOTION TABLES

The following tables list the amount of movement of the image across the focal plane of the camera resulting from the forward motion of the aircraft. It is directly proportional to the camera focal length, aircraft velocity and shutter speed, and inversely proportional to height above ground.

It should be noted that additional image motion effects may be caused by the rotational movement of the aircraft; i.e. - pitch, roll and yaw. These effects do not vary with height above ground.

A pitch or roll of one degree per second at any altitude produces approximately the same image motion as a forward velocity of 207 knots at 20,000 feet AGL or 414 knots at 40,000 feet AGL. Aircraft vibration is usually the limiting factor affecting image motion.

In the following tables, the image motion is in millimetres.

IMAGE MOTION

Focal Length 3.47 Inches

RC-10

Shutter Speed 1/ 100th of a Second

Height (Ft)	Ground Speed (Knots)						
	100	150	200	250	300	350	400
1000	.14886	.22328	.29771	.37214	.44657	.52099	.59542
2000	.07443	.11164	.14886	.18607	.22328	.26050	.29771
3000	.04962	.07443	.09924	.12405	.14886	.17366	.19847
4000	.03721	.05582	.07443	.09303	.11164	.13025	.14886
5000	.02977	.04466	.05954	.07443	.08931	.10420	.11908
6000	.02481	.03721	.04962	.06202	.07443	.08683	.09924
7000	.02127	.03190	.04253	.05316	.06380	.07443	.08506
8000	.01861	.02791	.03721	.04652	.05582	.06512	.07443
9000	.01654	.02481	.03308	.04135	.04962	.05789	.06616
10000	.01489	.02233	.02977	.03721	.04466	.05210	.05954
11000	.01353	.02030	.02706	.03383	.04060	.04736	.05413
12000	.01240	.01861	.02481	.03101	.03721	.04342	.04962
13000	.01145	.01718	.02290	.02863	.03435	.04008	.04580
14000	.01063	.01595	.02127	.02658	.03190	.03721	.04253
15000	.00992	.01489	.01985	.02481	.02977	.03473	.03969
16000	.00930	.01396	.01861	.02326	.02791	.03256	.03721
17000	.00876	.01313	.01751	.02189	.02627	.03065	.03502
18000	.00827	.01240	.01654	.02067	.02481	.02894	.03308
19000	.00783	.01175	.01567	.01959	.02350	.02742	.03134
20000	.00744	.01116	.01489	.01861	.02233	.02605	.02977
21000	.00709	.01063	.01418	.01772	.02127	.02481	.02835
22000	.00677	.01015	.01353	.01692	.02030	.02368	.02706
23000	.00647	.00971	.01294	.01618	.01942	.02265	.02589
24000	.00620	.00930	.01240	.01551	.01861	.02171	.02481
25000	.00595	.00893	.01191	.01489	.01786	.02084	.02382
26000	.00573	.00859	.01145	.01431	.01718	.02004	.02290
27000	.00551	.00827	.01103	.01378	.01654	.01930	.02205
28000	.00532	.00797	.01063	.01329	.01595	.01861	.02127
29000	.00513	.00770	.01027	.01283	.01540	.01797	.02053
30000	.00496	.00744	.00992	.01240	.01489	.01737	.01985
31000	.00480	.00720	.00960	.01200	.01441	.01681	.01921
32000	.00465	.00698	.00930	.01163	.01396	.01628	.01861
33000	.00451	.00677	.00902	.01128	.01353	.01579	.01804
34000	.00438	.00657	.00876	.01095	.01313	.01532	.01751
35000	.00425	.00638	.00851	.01063	.01276	.01489	.01701
36000	.00413	.00620	.00827	.01034	.01240	.01447	.01654
37000	.00402	.00603	.00805	.01006	.01207	.01408	.01609
38000	.00392	.00588	.00783	.00979	.01175	.01371	.01567
39000	.00382	.00573	.00763	.00954	.01145	.01336	.01527

IMAGE MOTION

Focal Length 6.00 Inches RC-8
 Shutter Speed 1/ 100th of a Second RC-10

Height (Ft)	Ground Speed (Knots)						
	100	150	200	250	300	350	400
1000	.25739	.38608	.51477	.64347	.77216	.90085	1.02955
2000	.12869	.19304	.25739	.32173	.38608	.45043	.51477
3000	.08580	.12869	.17159	.21449	.25739	.30028	.34318
4000	.06435	.09652	.12869	.16087	.19304	.22521	.25739
5000	.05148	.07722	.10295	.12869	.15443	.18017	.20591
6000	.04290	.06435	.08580	.10724	.12869	.15014	.17159
7000	.03677	.05515	.07354	.09192	.11031	.12869	.14708
8000	.03217	.04826	.06435	.08043	.09652	.11261	.12869
9000	.02860	.04290	.05720	.07150	.08580	.10009	.11439
10000	.02574	.03861	.05148	.06435	.07722	.09009	.10295
11000	.02340	.03510	.04680	.05850	.07020	.08190	.09360
12000	.02145	.03217	.04290	.05362	.06435	.07507	.08580
13000	.01980	.02970	.03960	.04950	.05940	.06930	.07920
14000	.01838	.02758	.03677	.04596	.05515	.06435	.07354
15000	.01716	.02574	.03432	.04290	.05148	.06006	.06864
16000	.01609	.02413	.03217	.04022	.04826	.05630	.06435
17000	.01514	.02271	.03028	.03785	.04542	.05299	.06056
18000	.01430	.02145	.02860	.03575	.04290	.05005	.05720
19000	.01355	.02032	.02709	.03387	.04064	.04741	.05419
20000	.01287	.01930	.02574	.03217	.03861	.04504	.05148
21000	.01226	.01838	.02451	.03064	.03677	.04290	.04903
22000	.01170	.01755	.02340	.02925	.03510	.04095	.04680
23000	.01119	.01679	.02238	.02798	.03357	.03917	.04476
24000	.01072	.01609	.02145	.02681	.03217	.03754	.04290
25000	.01030	.01544	.02059	.02574	.03089	.03603	.04118
26000	.00990	.01485	.01980	.02475	.02970	.03465	.03960
27000	.00953	.01430	.01907	.02383	.02860	.03336	.03813
28000	.00919	.01379	.01838	.02298	.02758	.03217	.03677
29000	.00888	.01331	.01775	.02219	.02663	.03106	.03550
30000	.00858	.01287	.01716	.02145	.02574	.03003	.03432
31000	.00830	.01245	.01661	.02076	.02491	.02906	.03321
32000	.00804	.01207	.01609	.02011	.02413	.02815	.03217
33000	.00780	.01170	.01560	.01950	.02340	.02730	.03120
34000	.00757	.01136	.01514	.01893	.02271	.02650	.03028
35000	.00735	.01103	.01471	.01838	.02206	.02574	.02942
36000	.00715	.01072	.01430	.01787	.02145	.02502	.02860
37000	.00696	.01043	.01391	.01739	.02087	.02435	.02783
38000	.00677	.01016	.01355	.01693	.02032	.02371	.02709
39000	.00660	.00990	.01320	.01650	.01980	.02310	.02640

IMAGE MOTION

Focal Length 1.50 Inches
 Shutter Speed 1/ 500th of a Second

VINTEN

Height (Ft)	Ground Speed (Knots)						
	100	150	200	250	300	350	400
1000	.01287	.01930	.02574	.03217	.03861	.04504	.05148
2000	.00643	.00965	.01287	.01609	.01930	.02252	.02574
3000	.00429	.00643	.00858	.01072	.01287	.01501	.01716
4000	.00322	.00483	.00643	.00804	.00965	.01126	.01287
5000	.00257	.00386	.00515	.00643	.00772	.00901	.01030
6000	.00214	.00322	.00429	.00536	.00643	.00751	.00858
7000	.00184	.00276	.00368	.00460	.00552	.00643	.00735
8000	.00161	.00241	.00322	.00402	.00483	.00563	.00643
9000	.00143	.00214	.00286	.00357	.00429	.00500	.00572
10000	.00129	.00193	.00257	.00322	.00386	.00450	.00515
11000	.00117	.00175	.00234	.00292	.00351	.00409	.00468
12000	.00107	.00161	.00214	.00268	.00322	.00375	.00429
13000	.00099	.00148	.00198	.00247	.00297	.00346	.00396
14000	.00092	.00138	.00184	.00230	.00276	.00322	.00368
15000	.00086	.00129	.00172	.00214	.00257	.00300	.00343
16000	.00080	.00121	.00161	.00201	.00241	.00282	.00322
17000	.00076	.00114	.00151	.00189	.00227	.00265	.00303
18000	.00071	.00107	.00143	.00179	.00214	.00250	.00286
19000	.00068	.00102	.00135	.00169	.00203	.00237	.00271
20000	.00064	.00097	.00129	.00161	.00193	.00225	.00257
21000	.00061	.00092	.00123	.00153	.00184	.00214	.00245
22000	.00058	.00088	.00117	.00146	.00175	.00205	.00234
23000	.00056	.00084	.00112	.00140	.00168	.00196	.00224
24000	.00054	.00080	.00107	.00134	.00161	.00188	.00214
25000	.00051	.00077	.00103	.00129	.00154	.00180	.00206
26000	.00049	.00074	.00099	.00124	.00148	.00173	.00198
27000	.00048	.00071	.00095	.00119	.00143	.00167	.00191
28000	.00046	.00069	.00092	.00115	.00138	.00161	.00184
29000	.00044	.00067	.00089	.00111	.00133	.00155	.00178
30000	.00043	.00064	.00086	.00107	.00129	.00150	.00172
31000	.00042	.00062	.00083	.00104	.00125	.00145	.00166
32000	.00040	.00060	.00080	.00101	.00121	.00141	.00161
33000	.00039	.00058	.00078	.00097	.00117	.00136	.00156
34000	.00038	.00057	.00076	.00095	.00114	.00132	.00151
35000	.00037	.00055	.00074	.00092	.00110	.00129	.00147
36000	.00036	.00054	.00071	.00089	.00107	.00125	.00143
37000	.00035	.00052	.00070	.00087	.00104	.00122	.00139
38000	.00034	.00051	.00068	.00085	.00102	.00119	.00135
39000	.00033	.00049	.00066	.00082	.00099	.00115	.00132

IMAGE MOTION

Focal Length 3.00 Inches
 Shutter Speed 1/ 500th of a Second

VINTEN

Height (Ft)	Ground Speed (Knots)						
	100	150	200	250	300	350	400
1000	.02574	.03861	.05148	.06435	.07722	.09009	.10295
2000	.01287	.01930	.02574	.03217	.03861	.04504	.05148
3000	.00858	.01287	.01716	.02145	.02574	.03003	.03432
4000	.00643	.00965	.01287	.01609	.01930	.02252	.02574
5000	.00515	.00772	.01030	.01287	.01544	.01802	.02059
6000	.00429	.00643	.00858	.01072	.01287	.01501	.01716
7000	.00368	.00552	.00735	.00919	.01103	.01287	.01471
8000	.00322	.00483	.00643	.00804	.00965	.01126	.01287
9000	.00286	.00429	.00572	.00715	.00858	.01001	.01144
10000	.00257	.00386	.00515	.00643	.00772	.00901	.01030
11000	.00234	.00351	.00468	.00585	.00702	.00819	.00936
12000	.00214	.00322	.00429	.00536	.00643	.00751	.00858
13000	.00198	.00297	.00396	.00495	.00594	.00693	.00792
14000	.00184	.00276	.00368	.00460	.00552	.00643	.00735
15000	.00172	.00257	.00343	.00429	.00515	.00601	.00686
16000	.00161	.00241	.00322	.00402	.00483	.00563	.00643
17000	.00151	.00227	.00303	.00379	.00454	.00530	.00606
18000	.00143	.00214	.00286	.00357	.00429	.00500	.00572
19000	.00135	.00203	.00271	.00339	.00406	.00474	.00542
20000	.00129	.00193	.00257	.00322	.00386	.00450	.00515
21000	.00123	.00184	.00245	.00306	.00368	.00429	.00490
22000	.00117	.00175	.00234	.00292	.00351	.00409	.00468
23000	.00112	.00168	.00224	.00280	.00336	.00392	.00448
24000	.00107	.00161	.00214	.00268	.00322	.00375	.00429
25000	.00103	.00154	.00206	.00257	.00309	.00360	.00412
26000	.00099	.00148	.00198	.00247	.00297	.00346	.00396
27000	.00095	.00143	.00191	.00238	.00286	.00334	.00381
28000	.00092	.00138	.00184	.00230	.00276	.00322	.00368
29000	.00089	.00133	.00178	.00222	.00266	.00311	.00355
30000	.00086	.00129	.00172	.00214	.00257	.00300	.00343
31000	.00083	.00125	.00166	.00208	.00249	.00291	.00332
32000	.00080	.00121	.00161	.00201	.00241	.00282	.00322
33000	.00078	.00117	.00156	.00195	.00234	.00273	.00312
34000	.00076	.00114	.00151	.00189	.00227	.00265	.00303
35000	.00074	.00110	.00147	.00184	.00221	.00257	.00294
36000	.00071	.00107	.00143	.00179	.00214	.00250	.00286
37000	.00070	.00104	.00139	.00174	.00209	.00243	.00278
38000	.00068	.00102	.00135	.00169	.00203	.00237	.00271
39000	.00066	.00099	.00132	.00165	.00198	.00231	.00264

IMAGE MOTION

Focal Length 6.00 Inches

VINTEN

Shutter Speed 1/ 500th of a Second

Height (Ft)	Ground Speed (Knots)						
	100	150	200	250	300	350	400
1000	.05148	.07722	.10295	.12869	.15443	.18017	.20591
2000	.02574	.03861	.05148	.06435	.07722	.09009	.10295
3000	.01716	.02574	.03432	.04290	.05148	.06006	.06864
4000	.01287	.01930	.02574	.03217	.03861	.04504	.05148
5000	.01030	.01544	.02059	.02574	.03089	.03603	.04118
6000	.00858	.01287	.01716	.02145	.02574	.03003	.03432
7000	.00735	.01103	.01471	.01838	.02206	.02574	.02942
8000	.00643	.00965	.01287	.01609	.01930	.02252	.02574
9000	.00572	.00858	.01144	.01430	.01716	.02002	.02288
10000	.00515	.00772	.01030	.01287	.01544	.01802	.02059
11000	.00468	.00702	.00936	.01170	.01404	.01638	.01872
12000	.00429	.00643	.00858	.01072	.01287	.01501	.01716
13000	.00396	.00594	.00792	.00990	.01188	.01386	.01584
14000	.00368	.00552	.00735	.00919	.01103	.01287	.01471
15000	.00343	.00515	.00686	.00858	.01030	.01201	.01373
16000	.00322	.00483	.00643	.00804	.00965	.01126	.01287
17000	.00303	.00454	.00606	.00757	.00908	.01060	.01211
18000	.00286	.00429	.00572	.00715	.00858	.01001	.01144
19000	.00271	.00406	.00542	.00677	.00813	.00948	.01084
20000	.00257	.00386	.00515	.00643	.00772	.00901	.01030
21000	.00245	.00368	.00490	.00613	.00735	.00858	.00981
22000	.00234	.00351	.00468	.00585	.00702	.00819	.00936
23000	.00224	.00336	.00448	.00560	.00671	.00783	.00895
24000	.00214	.00322	.00429	.00536	.00643	.00751	.00858
25000	.00206	.00309	.00412	.00515	.00618	.00721	.00824
26000	.00198	.00297	.00396	.00495	.00594	.00693	.00792
27000	.00191	.00286	.00381	.00477	.00572	.00667	.00763
28000	.00184	.00276	.00368	.00460	.00552	.00643	.00735
29000	.00178	.00266	.00355	.00444	.00533	.00621	.00710
30000	.00172	.00257	.00343	.00429	.00515	.00601	.00686
31000	.00166	.00249	.00332	.00415	.00498	.00581	.00664
32000	.00161	.00241	.00322	.00402	.00483	.00563	.00643
33000	.00156	.00234	.00312	.00390	.00468	.00546	.00624
34000	.00151	.00227	.00303	.00379	.00454	.00530	.00606
35000	.00147	.00221	.00294	.00368	.00441	.00515	.00588
36000	.00143	.00214	.00286	.00357	.00429	.00500	.00572
37000	.00139	.00209	.00278	.00348	.00417	.00487	.00557
38000	.00135	.00203	.00271	.00339	.00406	.00474	.00542
39000	.00132	.00198	.00264	.00330	.00396	.00462	.00528

IMAGE MOTION

Focal Length 1.57 Inches
 Shutter Speed 1/ 500th of a Second

HASSELBLAD

Height (Ft)	Ground Speed (Knots)						
	100	150	200	250	300	350	400
1000	.01351	.02027	.02702	.03378	.04053	.04729	.05404
2000	.00676	.01013	.01351	.01689	.02027	.02364	.02702
3000	.00450	.00676	.00901	.01126	.01351	.01576	.01801
4000	.00338	.00507	.00676	.00844	.01013	.01182	.01351
5000	.00270	.00405	.00540	.00676	.00811	.00946	.01081
6000	.00225	.00338	.00450	.00563	.00676	.00788	.00901
7000	.00193	.00290	.00386	.00483	.00579	.00676	.00772
8000	.00169	.00253	.00338	.00422	.00507	.00591	.00676
9000	.00150	.00225	.00300	.00375	.00450	.00525	.00600
10000	.00135	.00203	.00270	.00338	.00405	.00473	.00540
11000	.00123	.00184	.00246	.00307	.00368	.00430	.00491
12000	.00113	.00169	.00225	.00281	.00338	.00394	.00450
13000	.00104	.00156	.00208	.00260	.00312	.00364	.00416
14000	.00097	.00145	.00193	.00241	.00290	.00338	.00386
15000	.00090	.00135	.00180	.00225	.00270	.00315	.00360
16000	.00084	.00127	.00169	.00211	.00253	.00296	.00338
17000	.00079	.00119	.00159	.00199	.00238	.00278	.00318
18000	.00075	.00113	.00150	.00188	.00225	.00263	.00300
19000	.00071	.00107	.00142	.00178	.00213	.00249	.00284
20000	.00068	.00101	.00135	.00169	.00203	.00236	.00270
21000	.00064	.00097	.00129	.00161	.00193	.00225	.00257
22000	.00061	.00092	.00123	.00154	.00184	.00215	.00246
23000	.00059	.00088	.00117	.00147	.00176	.00206	.00235
24000	.00056	.00084	.00113	.00141	.00169	.00197	.00225
25000	.00054	.00081	.00108	.00135	.00162	.00189	.00216
26000	.00052	.00078	.00104	.00130	.00156	.00182	.00208
27000	.00050	.00075	.00100	.00125	.00150	.00175	.00200
28000	.00048	.00072	.00097	.00121	.00145	.00169	.00193
29000	.00047	.00070	.00093	.00116	.00140	.00163	.00186
30000	.00045	.00068	.00090	.00113	.00135	.00158	.00180
31000	.00044	.00065	.00087	.00109	.00131	.00153	.00174
32000	.00042	.00063	.00084	.00106	.00127	.00148	.00169
33000	.00041	.00061	.00082	.00102	.00123	.00143	.00164
34000	.00040	.00060	.00079	.00099	.00119	.00139	.00159
35000	.00039	.00058	.00077	.00097	.00116	.00135	.00154
36000	.00038	.00056	.00075	.00094	.00113	.00131	.00150
37000	.00037	.00055	.00073	.00091	.00110	.00128	.00146
38000	.00036	.00053	.00071	.00089	.00107	.00124	.00142
39000	.00035	.00052	.00069	.00087	.00104	.00121	.00139

IMAGE MOTION

Focal Length 3.15 Inches

HASSELBLAD

Shutter Speed 1/ 500th of a Second

Height (Ft)	Ground Speed (Knots)						
	100	150	200	250	300	350	400
1000	.02702	.04053	.05404	.06756	.08107	.09458	.10809
2000	.01351	.02027	.02702	.03378	.04053	.04729	.05404
3000	.00901	.01351	.01801	.02252	.02702	.03153	.03603
4000	.00676	.01013	.01351	.01689	.02027	.02364	.02702
5000	.00540	.00811	.01081	.01351	.01621	.01892	.02162
6000	.00450	.00676	.00901	.01126	.01351	.01576	.01801
7000	.00386	.00579	.00772	.00965	.01158	.01351	.01544
8000	.00338	.00507	.00676	.00844	.01013	.01182	.01351
9000	.00300	.00450	.00600	.00751	.00901	.01051	.01201
10000	.00270	.00405	.00540	.00676	.00811	.00946	.01081
11000	.00246	.00368	.00491	.00614	.00737	.00860	.00983
12000	.00225	.00338	.00450	.00563	.00676	.00788	.00901
13000	.00208	.00312	.00416	.00520	.00624	.00728	.00831
14000	.00193	.00290	.00386	.00483	.00579	.00676	.00772
15000	.00180	.00270	.00360	.00450	.00540	.00631	.00721
16000	.00169	.00253	.00338	.00422	.00507	.00591	.00676
17000	.00159	.00238	.00318	.00397	.00477	.00556	.00636
18000	.00150	.00225	.00300	.00375	.00450	.00525	.00600
19000	.00142	.00213	.00284	.00356	.00427	.00498	.00569
20000	.00135	.00203	.00270	.00338	.00405	.00473	.00540
21000	.00129	.00193	.00257	.00322	.00386	.00450	.00515
22000	.00123	.00184	.00246	.00307	.00368	.00430	.00491
23000	.00117	.00176	.00235	.00294	.00352	.00411	.00470
24000	.00113	.00169	.00225	.00281	.00338	.00394	.00450
25000	.00108	.00162	.00216	.00270	.00324	.00378	.00432
26000	.00104	.00156	.00208	.00260	.00312	.00364	.00416
27000	.00100	.00150	.00200	.00250	.00300	.00350	.00400
28000	.00097	.00145	.00193	.00241	.00290	.00338	.00386
29000	.00093	.00140	.00186	.00233	.00280	.00326	.00373
30000	.00090	.00135	.00180	.00225	.00270	.00315	.00360
31000	.00087	.00131	.00174	.00218	.00262	.00305	.00349
32000	.00084	.00127	.00169	.00211	.00253	.00296	.00338
33000	.00082	.00123	.00164	.00205	.00246	.00287	.00328
34000	.00079	.00119	.00159	.00199	.00238	.00278	.00318
35000	.00077	.00116	.00154	.00193	.00232	.00270	.00309
36000	.00075	.00113	.00150	.00188	.00225	.00263	.00300
37000	.00073	.00110	.00146	.00183	.00219	.00256	.00292
38000	.00071	.00107	.00142	.00178	.00213	.00249	.00284
39000	.00069	.00104	.00139	.00173	.00208	.00243	.00277

IMAGE MOTION

Focal Length 4.13 Inches

HASSELBLAD (U.V.)

Shutter Speed 1/ 500th of a Second

Height (Ft)	Ground Speed (Knots)						
	100	150	200	250	300	350	400
1000	.03547	.05320	.07094	.08867	.10640	.12414	.14187
2000	.01773	.02660	.03547	.04433	.05320	.06207	.07094
3000	.01182	.01773	.02365	.02956	.03547	.04138	.04729
4000	.00887	.01330	.01773	.02217	.02660	.03103	.03547
5000	.00709	.01064	.01419	.01773	.02128	.02483	.02837
6000	.00591	.00887	.01182	.01478	.01773	.02069	.02365
7000	.00507	.00760	.01013	.01267	.01520	.01773	.02027
8000	.00443	.00665	.00887	.01108	.01330	.01552	.01773
9000	.00394	.00591	.00788	.00985	.01182	.01379	.01576
10000	.00355	.00532	.00709	.00887	.01064	.01241	.01419
11000	.00322	.00484	.00645	.00806	.00967	.01129	.01290
12000	.00296	.00443	.00591	.00739	.00887	.01034	.01182
13000	.00273	.00409	.00546	.00682	.00818	.00955	.01091
14000	.00253	.00380	.00507	.00633	.00760	.00887	.01013
15000	.00236	.00355	.00473	.00591	.00709	.00828	.00946
16000	.00222	.00333	.00443	.00554	.00665	.00776	.00887
17000	.00209	.00313	.00417	.00522	.00626	.00730	.00835
18000	.00197	.00296	.00394	.00493	.00591	.00690	.00788
19000	.00187	.00280	.00373	.00467	.00560	.00653	.00747
20000	.00177	.00266	.00355	.00443	.00532	.00621	.00709
21000	.00169	.00253	.00338	.00422	.00507	.00591	.00676
22000	.00161	.00242	.00322	.00403	.00484	.00564	.00645
23000	.00154	.00231	.00308	.00386	.00463	.00540	.00617
24000	.00148	.00222	.00296	.00369	.00443	.00517	.00591
25000	.00142	.00213	.00284	.00355	.00426	.00497	.00567
26000	.00136	.00205	.00273	.00341	.00409	.00477	.00546
27000	.00131	.00197	.00263	.00328	.00394	.00460	.00525
28000	.00127	.00190	.00253	.00317	.00380	.00443	.00507
29000	.00122	.00183	.00245	.00306	.00367	.00428	.00489
30000	.00118	.00177	.00236	.00296	.00355	.00414	.00473
31000	.00114	.00172	.00229	.00286	.00343	.00400	.00458
32000	.00111	.00166	.00222	.00277	.00333	.00388	.00443
33000	.00107	.00161	.00215	.00269	.00322	.00376	.00430
34000	.00104	.00156	.00209	.00261	.00313	.00365	.00417
35000	.00101	.00152	.00203	.00253	.00304	.00355	.00405
36000	.00099	.00148	.00197	.00246	.00296	.00345	.00394
37000	.00096	.00144	.00192	.00240	.00288	.00336	.00383
38000	.00093	.00140	.00187	.00233	.00280	.00327	.00373
39000	.00091	.00136	.00182	.00227	.00273	.00318	.00364

APPENDIX E

SUN ANGLE TABLES

The following tables list the duration, for a given day at a given latitude, during which the angle between the sun and the horizon is equal to or greater than a specified minimum.

The solar noon table, when the solar noon correction is applied, gives the occurrence of solar noon in GMT for a given longitude.

DURATION OF SUN ANGLE

Latitude 40.00 Degrees North

Date	Sun Angle in Degrees								
	0	10	15	20	25	30	40	50	60
Jan 1	9:13	7:03	5:49	4:21	2:17				
Jan 11	9:22	7:16	6:04	4:41	2:52				
Jan 21	9:37	7:34	6:26	5:09	3:34				
Jan 31	9:56	7:57	6:52	5:41	4:18	2:23			
Feb 10	10:18	8:23	7:22	6:16	5:02	3:32			
Feb 20	10:42	8:51	7:53	6:51	5:44	4:28			
Mar 2	11:08	9:20	8:24	7:25	6:23	5:16	2:11		
Mar 12	11:34	9:49	8:54	7:58	7:00	5:58	3:31		
Mar 22	12:02	10:17	9:24	8:30	7:35	6:37	4:28	0:49	
Apr 1	12:29	10:45	9:52	8:59	8:06	7:10	5:12	2:42	
Apr 11	12:56	11:11	10:18	9:26	8:33	7:40	5:47	3:38	
Apr 21	13:21	11:35	10:42	9:50	8:58	8:05	6:17	4:18	1:36
May 1	13:45	11:57	11:04	10:11	9:19	8:27	6:40	4:48	2:35
May 11	14:07	12:16	11:22	10:29	9:37	8:44	6:59	5:11	3:09
May 21	14:25	12:32	11:37	10:44	9:51	8:59	7:14	5:27	3:32
May 31	14:39	12:43	11:48	10:54	10:01	9:09	7:24	5:38	3:47
Jun 10	14:48	12:51	11:55	11:01	10:08	9:15	7:30	5:45	3:55
Jun 20	14:51	12:54	11:58	11:03	10:10	9:17	7:32	5:47	3:58
Jun 30	14:48	12:51	11:56	11:01	10:08	9:15	7:31	5:45	3:55
Jul 10	14:39	12:44	11:49	10:55	10:02	9:09	7:25	5:39	3:47
Jul 20	14:26	12:32	11:38	10:44	9:52	8:59	7:15	5:28	3:33
Jul 30	14:08	12:17	11:23	10:30	9:38	8:45	7:00	5:12	3:11
Aug 9	13:47	11:58	11:05	10:12	9:20	8:28	6:42	4:50	2:37
Aug 19	13:23	11:36	10:44	9:51	8:59	8:06	6:18	4:21	1:41
Aug 29	12:57	11:12	10:20	9:28	8:35	7:41	5:49	3:41	
Sep 8	12:31	10:46	9:54	9:01	8:07	7:12	5:14	2:46	
Sep 18	12:04	10:19	9:26	8:32	7:37	6:39	4:31	1:03	
Sep 28	11:37	9:51	8:57	8:01	7:03	6:02	3:36		
Oct 8	11:10	9:22	8:26	7:28	6:27	5:20	2:20		
Oct 18	10:44	8:54	7:55	6:54	5:47	4:32			
Oct 28	10:20	8:26	7:25	6:19	5:06	3:37			
Nov 7	9:58	7:59	6:55	5:44	4:22	2:30			
Nov 17	9:39	7:36	6:28	5:11	3:38	0:38			
Nov 27	9:23	7:17	6:06	4:43	2:55				
Dec 7	9:13	7:04	5:50	4:23	2:19				
Dec 17	9:09	6:58	5:43	4:13	2:00				
Dec 27	9:10	7:00	5:45	4:15	2:05				

DURATION OF SUN ANGLE

Latitude 45.00 Degrees North

Date	Sun Angle in Degrees									
	0	10	15	20	25	30	40	50	60	
Jan 1	8:39	6:10	4:37	2:25						
Jan 11	8:51	6:26	4:58	3:02						
Jan 21	9:09	6:50	5:28	3:47						
Jan 31	9:31	7:19	6:03	4:35	2:33					
Feb 10	9:58	7:51	6:41	5:22	3:46	0:53				
Feb 20	10:27	8:25	7:19	6:08	4:47	3:02				
Mar 2	10:58	9:00	7:58	6:52	5:40	4:16				
Mar 12	11:30	9:34	8:35	7:33	6:27	5:14	1:40			
Mar 22	12:03	10:09	9:11	8:12	7:10	6:04	3:24			
Apr 1	12:35	10:42	9:45	8:47	7:48	6:46	4:27			
Apr 11	13:07	11:13	10:16	9:19	8:21	7:22	5:15	2:27		
Apr 21	13:37	11:41	10:45	9:48	8:51	7:54	5:53	3:31		
May 1	14:06	12:08	11:10	10:14	9:17	8:20	6:23	4:13	0:35	
May 11	14:32	12:31	11:33	10:35	9:39	8:42	6:47	4:44	2:06	
May 21	14:54	12:50	11:51	10:53	9:56	8:59	7:06	5:06	2:46	
May 31	15:11	13:04	12:04	11:06	10:09	9:12	7:19	5:21	3:09	
Jun 10	15:22	13:13	12:13	11:14	10:17	9:20	7:26	5:30	3:21	
Jun 20	15:26	13:16	12:16	11:17	10:19	9:22	7:29	5:33	3:25	
Jun 30	15:22	13:14	12:13	11:14	10:17	9:20	7:27	5:31	3:22	
Jul 10	15:12	13:05	12:05	11:07	10:09	9:13	7:19	5:22	3:10	
Jul 20	14:55	12:51	11:52	10:54	9:57	9:00	7:06	5:07	2:47	
Jul 30	14:33	12:32	11:34	10:37	9:40	8:43	6:48	4:46	2:09	
Aug 9	14:08	12:09	11:12	10:15	9:18	8:22	6:25	4:16	0:47	
Aug 19	13:39	11:43	10:46	9:50	8:53	7:55	5:55	3:34		
Aug 29	13:09	11:14	10:18	9:21	8:23	7:24	5:17	2:32		
Sep 8	12:37	10:44	9:47	8:49	7:50	6:48	4:30			
Sep 18	12:05	10:11	9:13	8:14	7:12	6:07	3:29			
Sep 28	11:32	9:37	8:38	7:36	6:31	5:19	1:53			
Oct 8	11:01	9:03	8:01	6:55	5:44	4:21				
Oct 18	10:30	8:28	7:23	6:12	4:52	3:10				
Oct 28	10:00	7:54	6:44	5:26	3:52	1:13				
Nov 7	9:34	7:21	6:06	4:39	2:40					
Nov 17	9:10	6:52	5:31	3:51	0:41					
Nov 27	8:52	6:28	5:01	3:06						
Dec 7	8:39	6:11	4:39	2:28						
Dec 17	8:34	6:03	4:28	2:07						
Dec 27	8:35	6:05	4:31	2:13						

DURATION OF SUN ANGLE

Latitude 50.00 Degrees North

Date	Sun Angle in Degrees								
	0	10	15	20	25	30	40	50	60
Jan 1	7:56	4:55	2:35						
Jan 11	8:11	5:18	3:14						
Jan 21	8:34	5:50	4:03						
Jan 31	9:02	6:28	4:54	2:44					
Feb 10	9:34	7:09	5:45	4:03	0:57				
Feb 20	10:09	7:52	6:35	5:08	3:16				
Mar 2	10:46	8:35	7:24	6:06	4:36	2:33			
Mar 12	11:24	9:16	8:09	6:58	5:40	4:08			
Mar 22	12:03	9:58	8:54	7:47	6:36	5:17	0:59		
Apr 1	12:42	10:37	9:34	8:30	7:23	6:12	3:15		
Apr 11	13:20	11:14	10:12	9:09	8:05	6:58	4:25		
Apr 21	13:56	11:49	10:46	9:44	8:41	7:36	5:17	1:59	
May 1	14:31	12:20	11:17	10:15	9:12	8:09	5:56	3:15	
May 11	15:03	12:48	11:44	10:41	9:39	8:36	6:27	4:01	
May 21	15:30	13:11	12:06	11:02	10:00	8:57	6:51	4:32	0:47
May 31	15:51	13:28	12:22	11:18	10:15	9:13	7:07	4:52	1:51
Jun 10	16:04	13:39	12:32	11:28	10:24	9:22	7:17	5:04	2:16
Jun 20	16:09	13:43	12:36	11:31	10:28	9:25	7:20	5:08	2:24
Jun 30	16:05	13:39	12:33	11:28	10:25	9:22	7:17	5:05	2:17
Jul 10	15:52	13:29	12:23	11:19	10:16	9:13	7:08	4:53	1:53
Jul 20	15:31	13:12	12:07	11:03	10:01	8:58	6:52	4:33	0:55
Jul 30	15:04	12:49	11:45	10:42	9:40	8:38	6:29	4:03	
Aug 9	14:33	12:22	11:19	10:16	9:14	8:11	5:59	3:18	
Aug 19	13:59	11:51	10:48	9:46	8:43	7:39	5:19	2:06	
Aug 29	13:22	11:16	10:14	9:11	8:07	7:00	4:29		
Sep 8	12:44	10:39	9:37	8:32	7:26	6:15	3:20		
Sep 18	12:06	10:01	8:56	7:50	6:39	5:21	1:15		
Sep 28	11:27	9:20	8:13	7:03	5:45	4:14			
Oct 8	10:49	8:38	7:28	6:11	4:42	2:43			
Oct 18	10:12	7:56	6:40	5:14	3:24				
Oct 28	9:37	7:13	5:50	4:09	1:19				
Nov 7	9:04	6:32	4:58	2:51					
Nov 17	8:36	5:53	4:07	0:44					
Nov 27	8:13	5:20	3:18						
Dec 7	7:57	4:57	2:38						
Dec 17	7:50	4:45	2:15						
Dec 27	7:52	4:48	2:21						

SOLAR NOON

Deg. Long.	Solar Noon (GMT)	Deg. Long.	Solar Noon (GMT)	Deg. Long.	Solar Noon (GMT)
35	14:20	77	17:08	119	19:56
36	14:24	78	17:12	120	20:00
37	14:28	79	17:16	121	20:04
38	14:32	80	17:20	122	20:08
39	14:36	81	17:24	123	20:12
40	14:40	82	17:28	124	20:16
41	14:44	83	17:32	125	20:20
42	14:48	84	17:36	126	20:24
43	14:52	85	17:40	127	20:28
44	14:56	86	17:44	128	20:32
45	15:00	87	17:48	129	20:36
46	15:04	88	17:52	130	20:40
47	15:08	89	17:56	131	20:44
48	15:12	90	18:00	132	20:48
49	15:16	91	18:04	133	20:52
50	15:20	92	18:08	134	20:56
51	15:24	93	18:12	135	21:00
52	15:28	94	18:16	136	21:04
53	15:32	95	18:20	137	21:08
54	15:36	96	18:24	138	21:12
55	15:40	97	18:28	139	21:16
56	15:44	98	18:32	140	21:20
57	15:48	99	18:36	141	21:24
58	15:52	100	18:40	142	21:28
59	15:56	101	18:44	143	21:32
60	16:00	102	18:48	144	21:36
61	16:04	103	18:52	145	21:40
62	16:08	104	18:56	146	21:44
63	16:12	105	19:00	147	21:48
64	16:16	106	19:04	148	21:52
65	16:20	107	19:08	149	21:56
66	16:24	108	19:12	150	22:00
67	16:28	109	19:16	151	22:04
68	16:32	110	19:20	152	22:08
69	16:36	111	19:24	153	22:12
70	16:40	112	19:28	154	22:16
71	16:44	113	19:32	155	22:20
72	16:48	114	19:36	156	22:24
73	16:52	115	19:40	157	22:28
74	16:56	116	19:44	158	22:32
75	17:00	117	19:48	159	22:36
76	17:04	118	19:52	160	22:40

CORRECTION TO SOLAR NOON

(Corrections in Minutes)

Date	Correction
Jan 1	+ 3
Jan 11	+ 8
Jan 21	+11
Jan 31	+13
Feb 10	+14
Feb 20	+14
Mar 2	+12
Mar 12	+10
Mar 22	+ 7
Apr 1	+ 4
Apr 11	0
Apr 21	- 2
May 1	- 3
May 11	- 4
May 21	- 4
May 31	- 3
Jun 10	- 1
Jun 20	+ 1
Jun 30	+ 4
Jul 10	+ 5
Jul 20	+ 6
Jul 30	+ 6
Aug 9	+ 6
Aug 19	+ 4
Aug 29	+ 1
Sep 8	- 2
Sep 18	- 6
Sep 28	- 9
Oct 8	-12
Oct 18	-14
Oct 28	-15
Nov 7	-15
Nov 17	-14
Nov 27	-12
Dec 7	- 9
Dec 17	- 5
Dec 27	0

APPENDIX F

COST ESTIMATING

The Airborne Operations Section produces the cost estimate found on the back of the task sheet. This estimate is prepared with the aid of a computer program. One function of this program is to adjust some of the estimation parameters. These adjustments are as follows:

1. When calculating the number of exposures, the forward overlap requested by the Principal Investigator is increased by 5 percent. This allows the sensor operator to adjust the actual overlap during the flight, so that it never falls below the requested overlap.
2. The calculated number of exposures per line is increased by two frames for 9" X 9" and four frames for 70 mm coverage to ensure that sufficient film is available for blank frames between successive flight lines.
3. Since some program calculations produce non-integer values, these values are rounded to the nearest integer value (i.e. \$24.70 will become \$25.00)
4. For loading and unloading the cameras and also for processing and reproduction, there must be extra blank film available on either end of the imagery. Therefore the calculated quantity of film required for a project is increased by twenty feet for each roll or part roll used to ensure that ten feet of leader and ten feet of trailer are available.

5. The line mileage and altitudes are unchanged.

A 9,200 ft. roll of magnetic tape costs \$105.00. the Mincom tape recorder is run at 30 inches per second. This information along with the average cruising speeds of the aircraft (DC-3 - 120 knots, Falcon - 350 knots) is used to estimate the magnetic tape charge.

In order to supply valid cost estimates the computer requires the following information. This information is provided either directly by the Principal Investigator or is calculated by Airborne Operations personnel.

1. Altitude above mean ground level.
2. Line mileage in nautical miles.
3. Number of flight lines.
4. The number of sensors and sensor types.
5. The film type for each camera.
6. The type of reproduction required for each sensor.
7. The forward overlap for each camera.

PROJECT -- 77-999
 COST ESTIMATE
 29-JUL-77

ALTITUDE(S) AGL (FT.) -- 1200 2000 25000
 LINE MILEAGE(S) (NM) -- 12 55 126
 SUGGESTED AIRCRAFT -- FALCON C-GRSD
 NO. OF FLIGHT LINES -- 7
 NO. OF SENSORS -- 3
 LINE MILEAGE CHARGE -- \$18.50
 TIME ON LINE -- 0.55 HR.

SENSOR No. AND TYPE	No. Exp. Ft. Film	FILM TYPE AND COST	PROC. COST	REPRODUCTION	REPRO. COST	TOTAL COST
SENSOR 1 9X9 3.5"	292 Exp. 263 Ft.	2445 \$ 296.00	COL. NEG. \$ 197.00	INDIV. PRINTS INDIV. TRANS. STEREO PAIRS	\$ 076.00 \$160.00 0 18.00	\$ 2847.00
SENSOR 2 9X9 6.0"	505 Exp. 440 Ft.	2443 \$ 817.00	COL. POS. \$ 331.00	ROLL PRINTS ROLL TRANS.	\$ 061.00 \$ 031.00	\$ 2690.00
SENSOR 3 IRLS	0 Exp. 55 Ft.	2438 \$ 6.00	B&W NEG. \$ 11.00	ROLL TRANS.	0 56.00	\$ 73.00
MAGNETIC TAPE -- 2481 Ft.						\$ 29.00
NHFL HANDLING CHARGE						\$ 2.00
193 LINE MILES @ \$18.50 PER NM					\$ 3571.00	
6 FLIGHT LINES @ 2 NM PER LINE = 12 NM @ \$18.50 PER NM					\$ 222.00	
TOTAL MILEAGE CHARGE						\$ 3793.00
GRAND TOTAL						\$ 9434.00

REMARKS

1. ESTIMATED COST PER FLIGHT.
2. DAY FLIGHT.

ALLOCATION: (CCRS USE ONLY)
 RECEIVER GENERAL -- \$ 4941.00
 NHFL -- \$ 4493.00

Figure 29 -- Sample Cost Estimate Print-out

0.1.1 First Frame on Film

0.1.1 First Frame on Film

0.1.1 First Frame on Film

APPENDIX G

FILM ANNOTATION

This section includes a brief description of the various formats and conventions used in the annotation of Remote Sensing aerial film.

G.1 9.5 INCH (25 CM) FILM

G.1.1 First Frame on Roll

Camera and No.
Lens and No.
Calibrated Focal Length
Film Type and No.
(1st) Project No. on Roll
Area and Province
Project Frame Nos.
Date Flown
Altitude Above Sea Level (metric)
(2nd) Project No. on Roll
Area and Province
Project Frame Nos.
Date Flown
Altitude Above Sea Level (metric)
Filter Type, Anti-vignetting Factor No.
Exposure
Line No. Direction - (Line Frame Nos.)
Frame No. - Roll No.

WILD RC 10, 1262
UAGII 3034
153.29 mm
AEROCROME INFRARED 2443
74-135
BRANDON, MANITOBA
(1-86)
JUNE 27, 1974
4,000' ASL, (1219 m ASL)
74-122
WINNIPEG, MANITOBA
(87-134)
JUNE 27, 1974
4,000' ASL, (1219 m ASL)
PAN 525, A.V., 2.2X
f 5.6, 1/350
LINE 4 → E (1-23)
N^o 1 A 37113

G.1.2 First Frame on Line

Every other frame will be annotated with line number and roll number in the lower left corner.

G.1.4 9.5 Inch Infrared Annotation

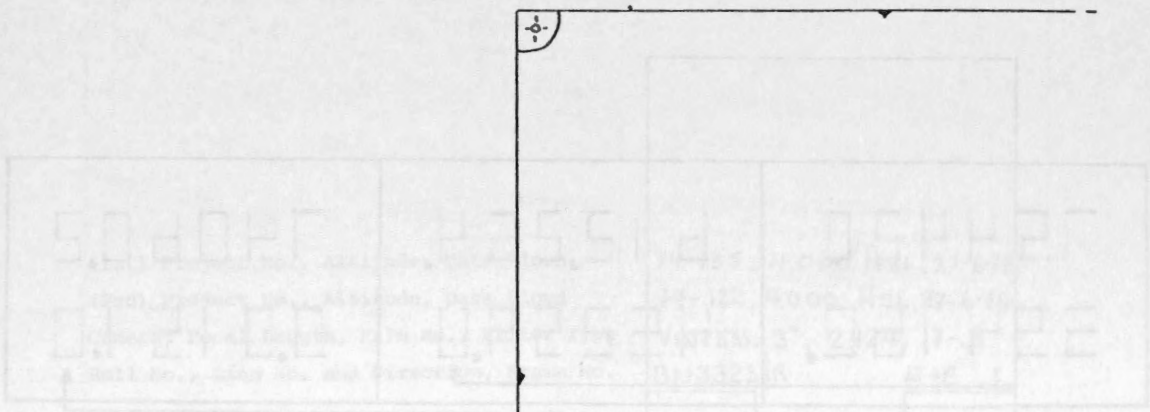

Line No. Direction - (Line Frame Nos.)
 Project No., Area and Province
 Date Flown, Altitude Above Sea Level
 Lens and No., Focal Length
 Frame No. - Roll No.

LINE 2 → W (24 - 47)
 74-135, BRANDON, MANITOBA
 JUNE 27, 1974, 4,000' ASL
 UAG II 3034, 153.29 mm
 N 24 A 37113

G.1.3 Other Frames

Every other frame will be annotated with frame number and roll number in the lower left corner.

G.1.4 9.5 inch In-camera Annotation

754420 554160.	612.254. 452590.	740602 001510.
-------------------	---------------------	-------------------

Long. (075° 44')
Time (20 hr. 55 min
41.60 sec)

Roll No. (0612)
Heading (254°)
Lat. (45° 25.9')

Project No. (74-060)
Flight Line (20)
Frame No. (151)

G.2.2 First Frame on Line

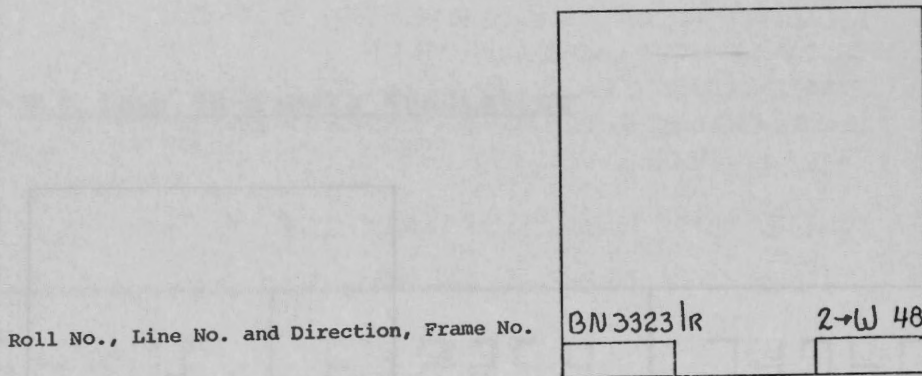

G.2.3 Other Frames

Every fourth frame will be annotated with the roll number and frame number.

G.2.4 70 mm In-camera Annotation

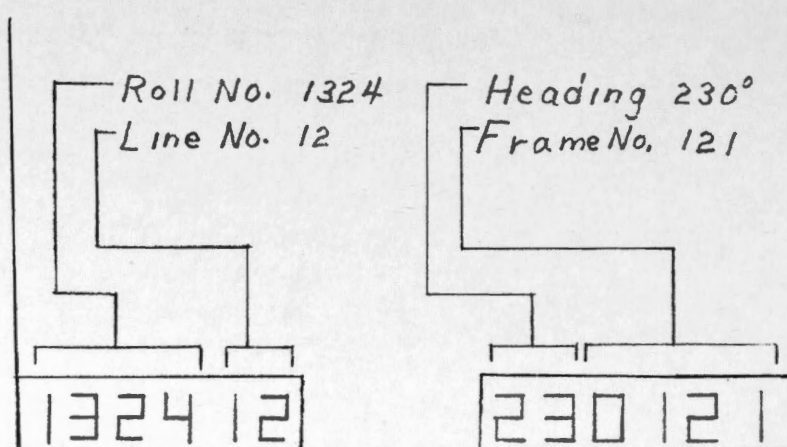

G.3 INFRARED SCANNER IMAGERY

G.3.1 Hand annotation

PROJECT 77-14		
NORTH SHORE LK. ERIE-SW ONTARIO		
FLOWN 29-APRIL-1977		
DAEDALUS IRLS 8-14μ DETECTOR		
ANALOGUE & 8-LEVEL SLICED DATA		
FILM NEGATIVE		
LINE 3W 1532Z ANALOGUE		
LINE 3W 1532Z RANGE 1-7		
LO=BB1	6.0°C	CLEAR
1	7.5	DENSITY 1
2	9.0	DENSITY 2
3	10.5	DENSITY 3
4	12.0	DENSITY 4
5	13.5	DENSITY 5
6	15.0°C	DENSITY 6
HI=BB2		BLACK

G.3.2 GRAMS ANNOTATION

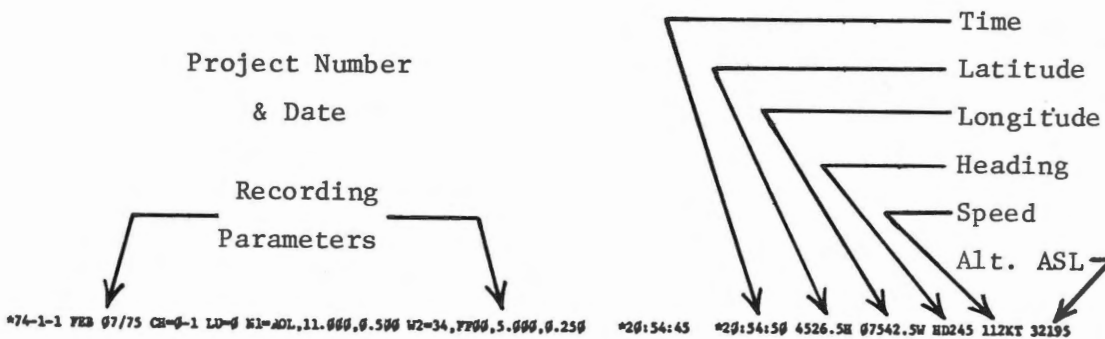

G.3.3 CSFR ANNOTATION

LINE 18 N 0637Z O/P TAPE RS5091 -3C TO 9C
 TAPE RS4975 LINES 00001 TO 06887
 PIXELS00001 TO 00904MAGNIFICATION 01
 BAND 01 BLACK BODY 000-30 0009

LINE SW	DENSITY	EXPOSURE
1	1.5	10.0
2	1.5	10.0
3	1.5	10.0
4	1.5	10.0
5	1.5	10.0
6	1.5	10.0
7	1.5	10.0
8	1.5	10.0
9	1.5	10.0
10	1.5	10.0
11	1.5	10.0
12	1.5	10.0
13	1.5	10.0
14	1.5	10.0
15	1.5	10.0
16	1.5	10.0
17	1.5	10.0
18	1.5	10.0
19	1.5	10.0
20	1.5	10.0
21	1.5	10.0
22	1.5	10.0
23	1.5	10.0
24	1.5	10.0
25	1.5	10.0
26	1.5	10.0
27	1.5	10.0
28	1.5	10.0
29	1.5	10.0
30	1.5	10.0
31	1.5	10.0
32	1.5	10.0
33	1.5	10.0
34	1.5	10.0
35	1.5	10.0
36	1.5	10.0
37	1.5	10.0
38	1.5	10.0
39	1.5	10.0
40	1.5	10.0
41	1.5	10.0
42	1.5	10.0
43	1.5	10.0
44	1.5	10.0
45	1.5	10.0
46	1.5	10.0
47	1.5	10.0
48	1.5	10.0
49	1.5	10.0
50	1.5	10.0
51	1.5	10.0
52	1.5	10.0
53	1.5	10.0
54	1.5	10.0
55	1.5	10.0
56	1.5	10.0
57	1.5	10.0
58	1.5	10.0
59	1.5	10.0
60	1.5	10.0
61	1.5	10.0
62	1.5	10.0
63	1.5	10.0
64	1.5	10.0
65	1.5	10.0
66	1.5	10.0
67	1.5	10.0
68	1.5	10.0
69	1.5	10.0
70	1.5	10.0
71	1.5	10.0
72	1.5	10.0
73	1.5	10.0
74	1.5	10.0
75	1.5	10.0
76	1.5	10.0
77	1.5	10.0
78	1.5	10.0
79	1.5	10.0
80	1.5	10.0
81	1.5	10.0
82	1.5	10.0
83	1.5	10.0
84	1.5	10.0
85	1.5	10.0
86	1.5	10.0
87	1.5	10.0
88	1.5	10.0
89	1.5	10.0
90	1.5	10.0
91	1.5	10.0
92	1.5	10.0
93	1.5	10.0
94	1.5	10.0
95	1.5	10.0
96	1.5	10.0
97	1.5	10.0
98	1.5	10.0
99	1.5	10.0
100	1.5	10.0

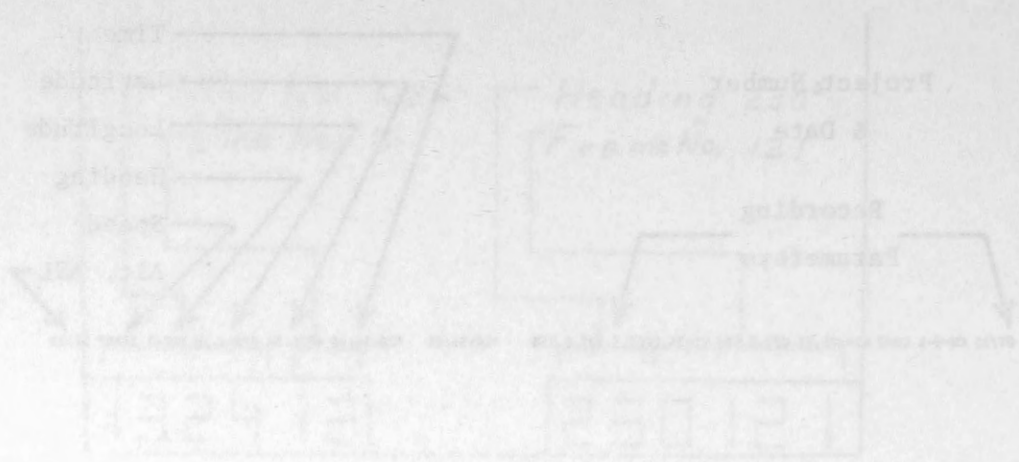

CAMERA	LENS	AREA	STATION	DESCRIPTION
9 X 8	50mm	1000	1000	1000
70mm	50mm	1000	1000	1000
70mm	50mm	1000	1000	1000
70mm	50mm	1000	1000	1000

APPENDIX H

SAMPLE REQUEST AND TASK SHEETS

The request sheet is filled in by the prospective user to explain his requirements to CCRS. The task sheet is produced by CCRS and is a final description of how the project is to be flown. The back of the task sheet contains an itemized cost breakdown for the project.

H.1 REQUEST SHEET

<p style="text-align: center;">REQUEST FOR AIRBORNE REMOTE SENSING FLIGHT</p> <p>Requesting Agency: CANADA CENTRE FOR REMOTE SENSING Date of Submission: 12 MARCH, 1975</p>	<p>AREA OTTAWA</p> <hr/> <p>MAP SHEET(S) 31G</p>
<p>PRINCIPAL INVESTIGATOR</p> <p>Name: GEORGE FITZGERALD Address: CANADA CENTRE FOR REMOTE SENSING 2464 SHEFFIELD ROAD OTTAWA, ONTARIO K1A 0E4 ATTN: AIRBORNE OPERATIONS SECTION Office: 998-3101 Area (613) Home: 123-4567</p>	<p>TIME PERIOD(S)</p> <p>Optimum: Jun 1 - 15 Aug 1 - 15 Acceptable: May 15 - Jun 30 Aug 1 - Aug 30</p> <hr/> <p>ALTITUDE(S)</p> <p>Optimum: 30,000'AGL Acceptable: 25,000 - 35,000</p>
<p>GROUND TRUTH CONTACT</p> <p>Name: Address: SAME AS ABOVE</p> <p>Telephone: Office: Home:</p>	<p>SUN ANGLE: 30°</p> <hr/> <p>% CLOUD: 10%</p> <hr/> <p>PRIMARY SENSOR: 9 x 9</p>
<p>APPLICATION AND OBJECTIVE (Attach additional sheets if necessary)</p> <p>TO ENSURE THAT ALL PERTINENT INFORMATION IS INCLUDED IN A PROJECT REQUEST</p>	<p>FORWARD OVERLAP:</p> <p>9 x 9 60 % 70 mm. 60 %</p> <hr/> <p>NOTES AND SPECIAL INSTRUCTIONS:</p> <p>NO NOTIFICATION NECE:</p> <p>Please attach topographic map(s) (1:</p>

H.2 REQUEST SHEET (CONTINUED)

CAMERA	LENS	FILM	FILTER	REPRODUCTION REQUESTED
9 x 9	6 inch	2443	MINUS BLUE	ROLL PRINTS
70 mm	3 inch	2402	.5 - .6	ROLL TRANSPARENCIES
70 mm	3 inch	2402	.6 - .7	ROLL TRANSPARENCIES
70 mm	3 inch	2424	.7 - .8	ROLL TRANSPARENCIES
70 mm	3 inch	2445	HAZE	ROLL TRANSPARENCIES
OTHER SENSORS		DETECTOR (Spectral Range)		
IRLS		8 - 14 um		ROLL TRANSPARENCIES
PRT 5		9.5 - 11.5 um		CHART PAPER
DELIVERY INSTRUCTIONS: Air Express Collect <input checked="" type="checkbox"/> Normal Prepaid <input type="checkbox"/>				
<p>PRIORITY 1</p> <p>SSARY PRIOR TO, OR AFTER FLIGHT.</p> <p>250,000 or 1:50,000 scale) showing exact area to be covered.</p>				
				EMR 800 CCRS

H.4 FRONT OF TASK SHEET (CONTINUED)

AREA OTTAWA	REQUESTING AGENCY CANADA CENTRE FOR REMOTE SENSING			Requested: Acceptable.	
PRINCIPAL INVESTIGATOR Name: GEORGE FITZGERALD Address: CANADA CENTRE FOR REMOTE SENSING 2464 SHEFFIELD ROAD OTTAWA, ONTARIO K1A 0E4 ATTN: AIRBORNE OPERATIONS SEC. Telephone: Office: 998-3101 Area (613) Home: 123-4567	LINE MILES 126 (4 lines)		ALTITUDE 30,400 ASL (Datum 400)		
	CAMERA	LENS	FILM	FILTERS	
GROUND TRUTH Name: Address: SAME AS ABOVE Telephone: Office: Home:	1	RC-10	6 inch	2443	525 2.0
	2	Vinten	3 inch	2402	.5 - .6
	3	Vinten	3 inch	2402	.6 - .7
	4	Vinten	3 inch	2424	.7 - .8
	5	Vinten	3 inch	2445	HF3
	6				
MISSION OBJECTIVE TO ENSURE THAT ALL PERTINENT INFORMATION IS INCLUDED IN A PROJECT REPORT	7				
	SENSOR			DETECTOR	
	8	DAEDALUS			8 - 14
	9	PRT-5			9.5 - 11.5
	10				
	11				
	12				

H.5 BACK OF TASK SHEET

APPROVAL COMMITTEE	FINALIZED WITH REQUESTOR: May 5, 1975
Approved <i>[Signature]</i>	TASKED: May 10, 1975
Rejected	REQUESTOR NOTIFIED PERIOD: May 30, 1975

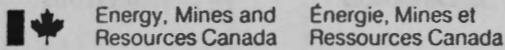

ESTIMATED CHA
(Based on the parameters)

SENSORS	FILM OR TAPE	INITIAL PROCESSING			
1. 9 x 9	67 Ft/RI @	\$124.00	67 Ft@	\$50.00	ROLL P
2. 70 mm	43 Ft/RI @	5.00	43 Ft@	9.00	ROLL T
3. 70 mm	43 Ft/RI @	5.00	43 Ft@	9.00	ROLL T
4. 70 mm	43 Ft/RI @	9.00	43 Ft@	9.00	ROLL T
5. 70 mm	43 Ft/RI @	25.00	43 Ft@	32.00	ROLL T
6. IRLS	27 Ft/RI @	3.00	27 Ft@	6.00	ROLL T
7. TAPE	1620 Ft/RI @	19.00	Ft@		
8. NAPL CHARGE	Ft/RI @		Ft@		
9. SENSOR LINE MILES		126 @	\$14.00		

Note: Film footage stated above includes leader and trailer required on each roll or part roll expended.

The Principal Investigator as named on the face of this document will normally be invoiced for services and material. Please insert your file or requisition number or other authority that may be quoted on the invoice.

The Project as outlined and estimated. It is understood that charges for may be pro-rated in accordance primary sensor.

Order No. 0001
Order No. plus (applicable) signature if required

[Signature]
Principal Investigator

H.6 BACK OF TASK SHEET (CONTINUED)

CCRS OPS. <i>W.D. Jamet</i> CFASU OPS PRIORITY: <input type="checkbox"/> 1 <input type="checkbox"/>	DELIVERY INSTRUCTIONS Air Express Collect <input checked="" type="checkbox"/> Normal Prepaid <input type="checkbox"/>
---	---

RGES PER FLIGHT
(outlined on the reverse)

	REPRODUCTION			TOTAL
RINTS	67	Ft/Ea @	\$100.00	\$274.00
RANSPARENCIES	43	Ft/Ea @	43.00	57.00
RANSPARENCIES	43	Ft/Ea @	43.00	57.00
RANSPARENCIES	43	Ft/Ea @	43.00	61.00
RANSPARENCIES	43	Ft/Ea @	64.00	121.00
RANSPARENCIES	27	Ft/Ea @	26.00	35.00
		Ft/Ea @		19.00
		Ft/Ea @		2.00
				\$1764.00
GRAND TOTAL				\$2390.00

ated charges are acceptable.
a partially completed Project
with results obtained from the

PLEASE RETURN SIGNED COPY TO
 Canada Centre for Remote Sensing
 2464 Sheffield Road
 Ottawa, Ontario
 K1A 0E4
Attn: Airborne Operations Section
 Telephone No. (613) 998-3101
 Telex CCRS: 053 3777

APPENDIX I

REGIONAL CENTRES

ALBERTA

C.D. Bricker
Alberta Remote Sensing Centre
11th Floor, Oxbridge Place
9820, 106th Street
Edmonton, Alberta
Telephone: 427-2381

BRITISH COLUMBIA

Ms. M. Redmond
Ministry of the Environment
Resource Analysis Branch
Parliament Buildings
Victoria, British Columbia
Telephone: 397-6387

MANITOBA

W. Best
Manitoba Remote Sensing Committee
1007 Century Street
Winnipeg, Manitoba
Telephone: 633-9543

NEW BRUNSWICK

B. Smith
Department of Natural Resources
Room 549
Centennial Building
Fredericton, New Brunswick
Telephone: 453-2441

NEWFOUNDLAND

A. A. Bruneau
Faculty of Engineering and Applied Science
Memorial University of Newfoundland
St. John's, Newfoundland
Telephone: 753-1200

NOVA SCOTIA

Paul Vandall, Jr.
Bedford Institute of Oceanography
P.O. Box 1006
Dartmouth, Nova Scotia
Telephone: 426-2673

ONTARIO

V. Zsilinszky
Ontario Centre for Remote Sensing
Ministry of Natural Resources
801 Bay Street
4th Floor
Toronto, Ontario
Telephone: 965-8411

PRINCE EDWARD ISLAND

N.W. Stewart
Department of Agriculture and Forestry
P.O. Box 1600
Charlottetown, Prince Edward Island
Telephone: 892-1267

QUEBEC

Herve Audet
Coordonnateur Quebecois en Teledetection
Service de la Cartographie
Ministere des Terres et Forets
1995 Ouest Boul. Charest
Ste-Foy, Quebec
Telephone: 643-6871

SASKATCHEWAN

W.E. Taylor
Saskatchewan Research Council
30 Campus Drive
Saskatoon, Saskatchewan
Telephone: 343-8251

APPENDIX J

INFRARED RADIOMETRY

J.1 INTRODUCTION

A brief description of infrared radiometry is included in this manual to familiarize new users of the CCRS infrared sensors to the basic principles of radiometry and measurement considerations including atmospheric parameters, infrared detectors, detector applications and radiometric calibrations.

The wavelength region discussed is the middle to far infrared - approximately one to twenty micrometers.

J.2 PRINCIPLES OF INFRARED RADIOMETRY

J.2.1 Kirchoff's Law

This conservation of energy law relates the power received and emitted by a system in thermal equilibrium. It states that for such a system:

$$R = \alpha H \quad (2.1.1)$$

where:

R = The radiant emittance, or power per unit area emitted by the system (S).

α = The absorptivity of S

H = The power per unit area striking S.

Since α cannot be greater than unity, the emitted power is a maximum for a perfect absorber, defined as a black body. For a black body:

$$\alpha = \xi = 1 \quad (2.1.2)$$

where ξ is the emissivity. For less efficient absorbers the emissivity is correspondingly lower so that in all cases:

$$\xi = \alpha \quad (2.1.3)$$

The conservation of energy may be restated as:

$$P_i = P_\alpha + P_\rho + P_\tau$$

where:

- P_i = incident power
- P_α = absorbed power
- P_ρ = reflected power
- P_τ = transmitted power

which reduces to:

$$\alpha + \rho + \tau = 1 \quad (2.1.4)$$

where:

- α = absorptivity
- ρ = reflectivity
- τ = transmissivity

For an opaque body:

$$\tau = 0$$

therefore:

$$\alpha = 1 - \rho$$

and from (2.1.3):

$$\xi = 1 - \rho$$

J.2.2 Stefan-Boltzmann Law

This law relates total emitted power of a body to its absolute temperature and is stated as:

$$R = \xi \sigma T^4 \quad (2.2.1)$$

where:

T = temperature in Kelvin

σ = Stefan-Boltzmann constant

J.2.3 Wavelength Distribution

Formulae for calculating the spectral radiant power distribution and the wavelength of peak power emission are the Planck Radiation Formula and the Wein Displacement Law.

Planck's formula is not included here(2) but a rule-of-thumb derivation from this formula indicates that approximately three-quarters of the power emitted from a body is at longer wavelengths than the wavelength of peak emission power (See Figure 30)

Wein's Displacement Law provides the formula for calculating the wavelength of peak emission (λ_{max}):

$$\lambda_{\text{max}} = 2893T \text{ um} \quad (2.3.1)$$

where:

T = temperature of emitter in Kelvin.

J.3 CONSIDERATIONS FOR THERMAL RADIOMETRIC MEASUREMENTS

The above principles and formulae provide the basis for calculating radiation emittance from a target of a given temperature and emissivity and selecting a suitable detector for the predicted power and wavelength distribution.

J.3.1 Atmospheric Parameters

Constituents of the atmosphere between the target and the remote sensor will absorb, emit, scatter and reflect infrared radiation in the path of the detector depending on the nature of the atmosphere and the wavelength of the radiation. Figure 31 is a graph of relative atmospheric transmission vs wavelength. Several "windows" are obvious where atmospheric attenuation is relatively low. Detectors in general are designed with band pass filters matching these "windows". The principle atmospheric components attenuating the signal in this wavelength region are water vapour and carbon dioxide. For accurate quantitative measurements the effect of water vapour on the signal must be calculated if the measurement is made under conditions of high humidity and long path length.

J.3.2 Infrared Detectors

The infrared detectors for the CCRS I.R. scanners and radiation thermometers described elsewhere in this manual, respond and are filtered to the nominal infrared atmospheric "windows" of 3-5 μm and 8-14 μm and are capable of being filtered to different bandpasses within these regions.

The detectors for the I.R. scanners are photon responsive detectors. The radiation thermometers employ thermistor type detectors that are thermal or heat sensing devices.

J.3.3 Detector Application

The choice of a detector or detectors for a particular application depends on many factors including: the need for quantitative measurement, the temperature of the target and the corresponding spectral wavelengths, the emissivity versus wavelength and the atmospheric parameters.

Typically, remote sensing infrared measurements are made to quantify terrain or target temperature over some areal distribution.

Recently, techniques have been developed to use remote sensing infrared measurements to characterize the nature or composition of the terrain by utilizing several infrared wavelengths and ratioing the signals to determine the spectral emissivity signatures.

J.3.4 Radiometric Calibrations

Radiometric calibration for the infrared scanners is provided by two temperature controlled black body references that each fill the field of view of the scanning optics once per scan. The reference temperatures are set to nominally bracket the expected range of terrain target temperatures. The recording of the infrared signal from each scan contains the reference temperatures. Subsequent data processing extracts the apparent temperature of a given scene element by interpolation of this signal between the two reference signals. (See section 5.9)

This linear interpolation does introduce some error because radiation varies as the fourth power of the temperature. (Equation 2.2.1) Figure 32 demonstrates this error for a given set of conditions.

The calibration for the radiation thermometer is a lab transfer calibration using a temperature controlled black body source and this transfer calibration is included with the data record.

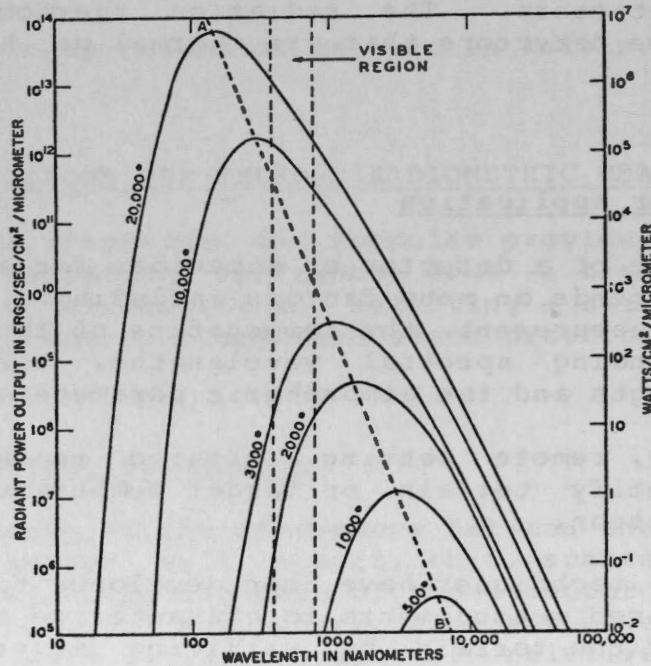

Figure 30 -- Spectral Distribution of Radiant Power from a Black Body

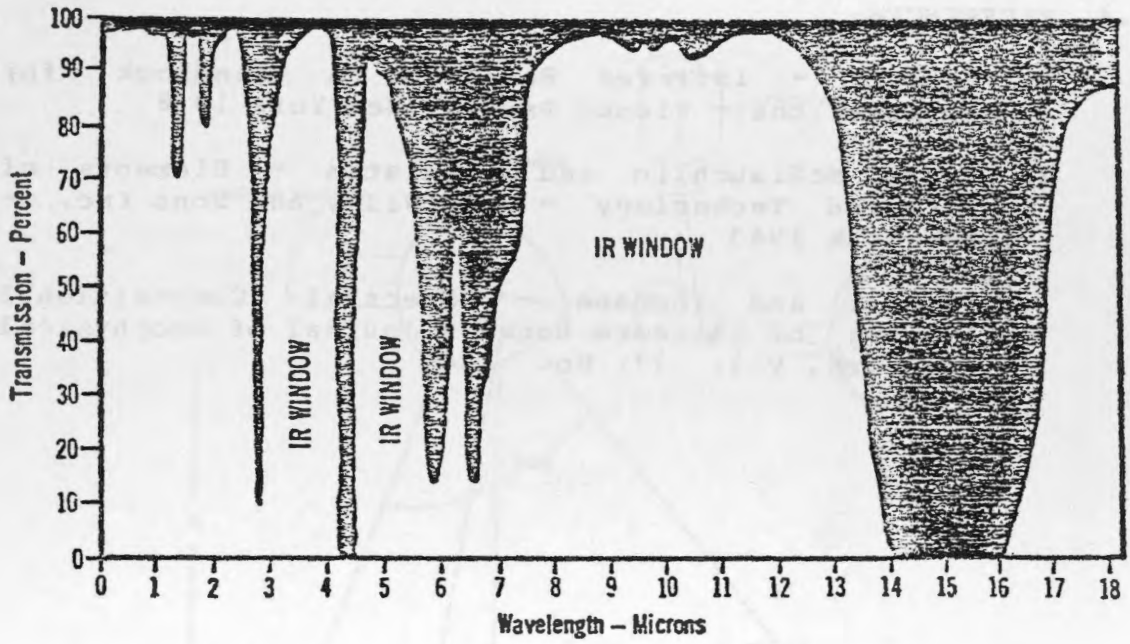

Figure 31 -- Infrared Atmospheric Transmission vs Wavelength

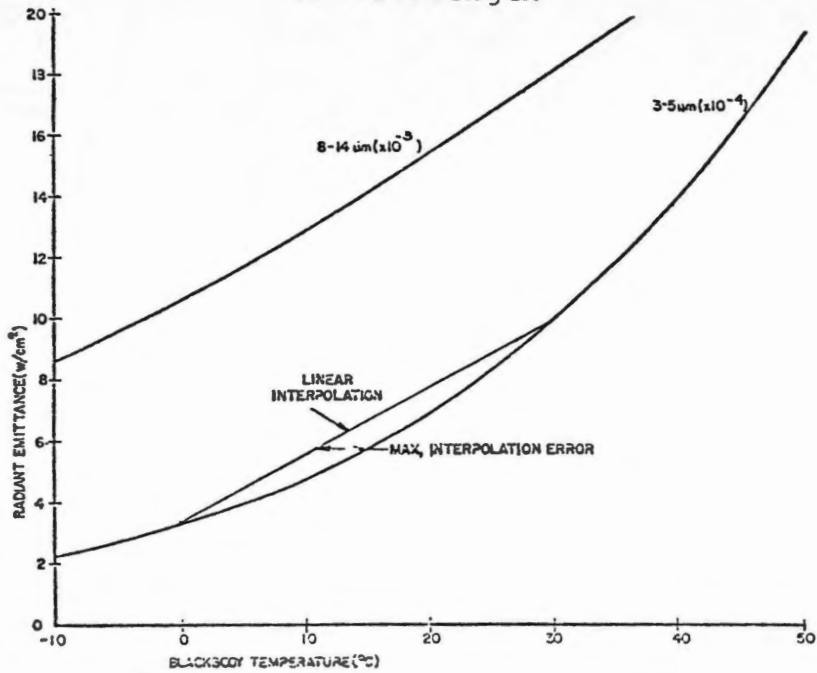

Figure 32 -- Radiated Energy vs Temperature for Blackbody Sources

J.4 REFERENCES

1. Bronson - Infrared Radiation A Handbook for Applications - Plenum Press - New York 1968
2. Kruse, McGlauchlin and McQuistan - Elements of Infrared Technology - John Wiley and Sons Inc. - New York 1963
3. Vincent and Thomson - Spectral Compositional Imaging of Silicate Rocks - Journal of Geophysical Research, Vol. 77, No. 14

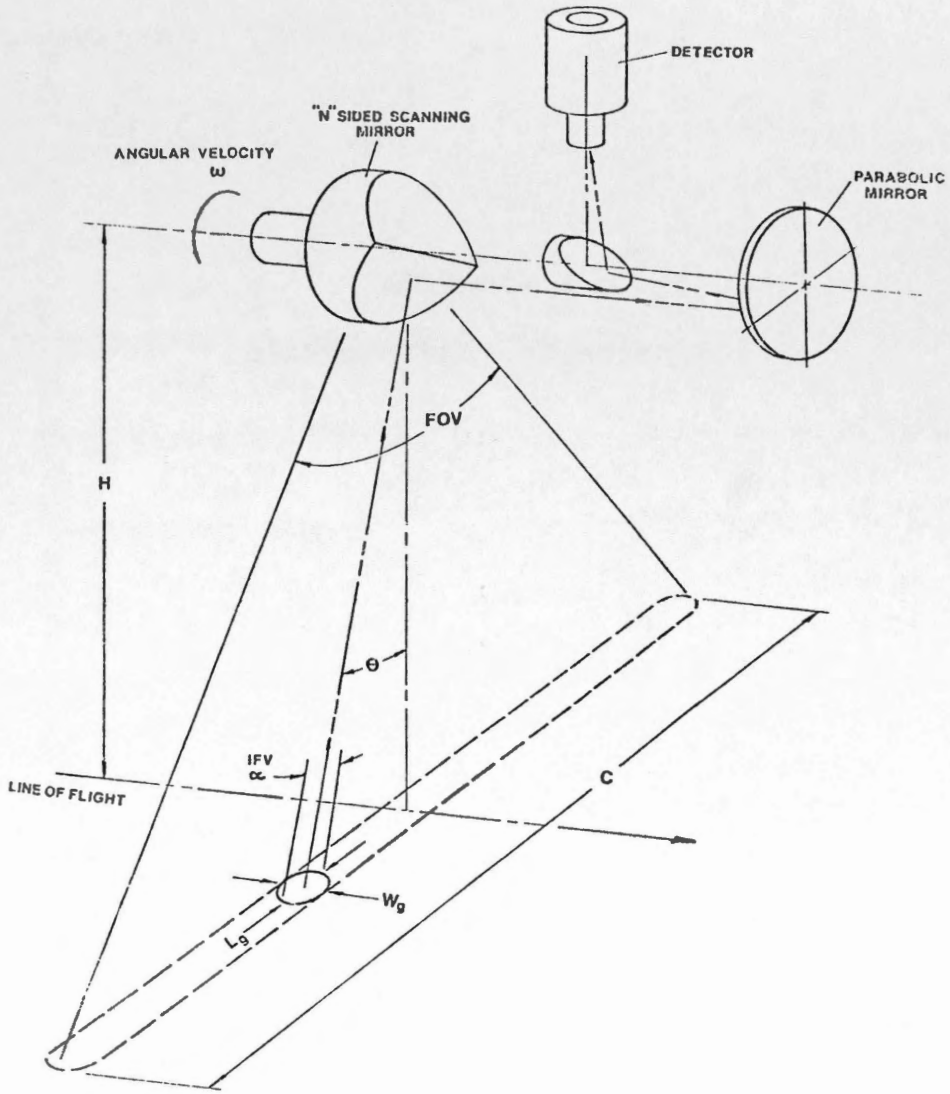

Figure 33 -- Scanner Diagram

APPENDIX K

COLOUR OF ORIGINAL SEEN	COLOUR OF REPRODUCED IMAGE
GREEN	BLUE
RED	GREEN
YELLOW	CYAN
BLUE	BLACK
BLACK	BLACK
RED	RED

APPENDIX K

MISCELLANEOUS INFORMATION

K.1 ELECTROMAGNETIC SPECTRAL CHARACTERISTICS AND DETECTORS

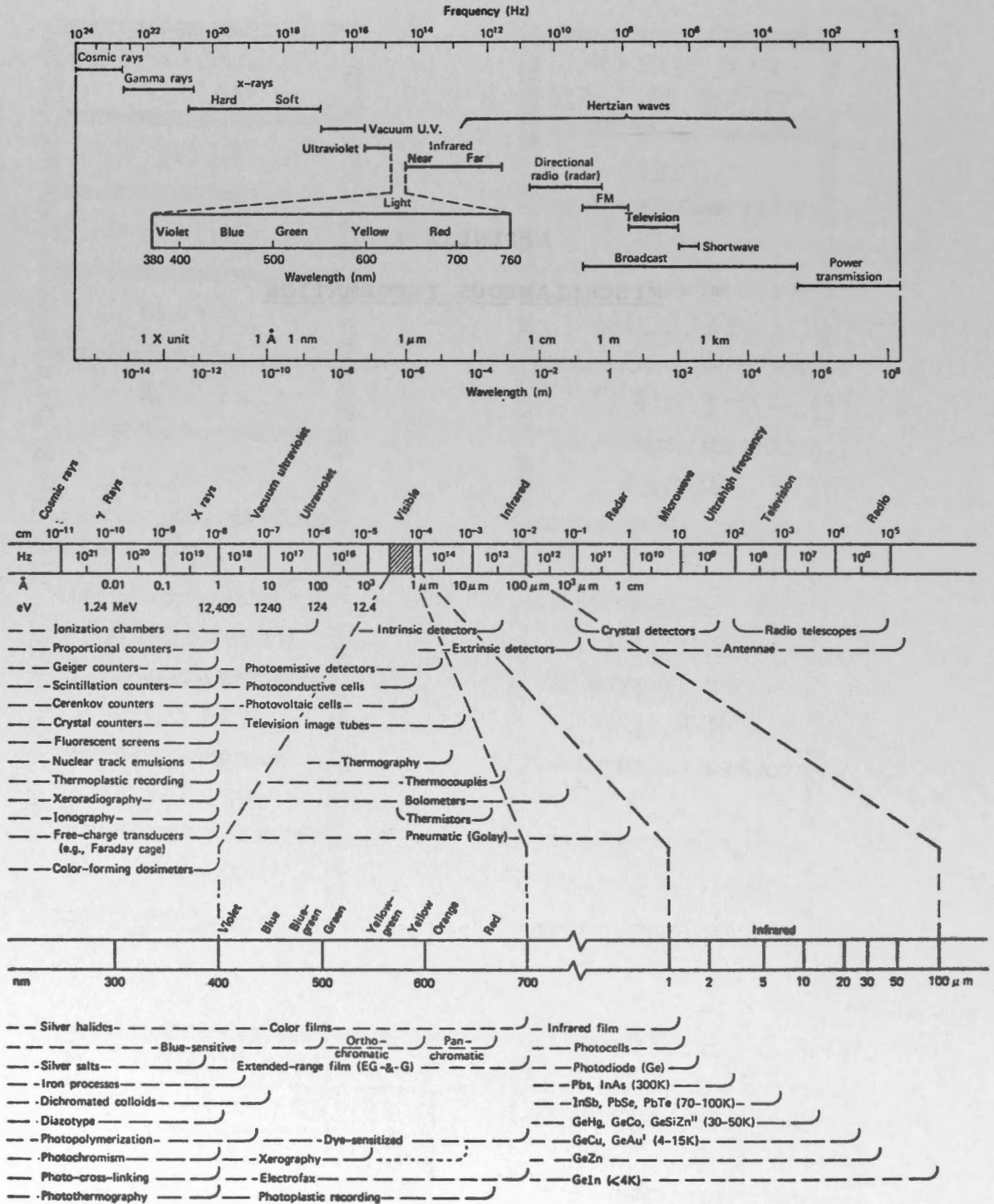

K.2 SOME SPECTRAL CHARACTERISTICS OF FALSE COLOUR FILM

COLOUR OF ORIGINAL SEEN
GREEN
RED
YELLOW
BLUE
BLACK
IR
GR & IR
R & IR
Y & IR
WHITE & IR

COLOUR OF POS IMAGE
BLUE
GREEN
CYAN
BLACK
BLACK
RED
MAGENTA
YELLOW
WHITE
WHITE

THE 3 SENSITIVE LAYERS ON THE FILM.

IR	GR	R
-----------	-----------	----------

MAGENTA = BL + R
YELLOW = R + GR
CYAN = BL + GR

K.3 CALIBRATED FOCAL LENGTHS OF CCRS METRIC CAMERAS

Camera	Lens No.	Nominal F.L.	Filter and No.	Calib. F.L. (mm)	Calib. Date
RC-8	UAG	385 6.0 in.	540 2.2 4493	151.948	3/09/76
			NAV 2.2 4518	151.948	3/09/76
RC-10	UAG-II 3005	6.0 in.	525 2.0 4315	153.122	13/01/75
RC-10	UAG-II 3022	6.0 in.	420 2.0 4570	153.000	11/06/74
RC-10	UAG-II 3034	6.0 in.	525 2.0 4360	153.282	11/02/75
RC-10	UAG-II 3048	6.0 in.		153.30	01/02/75
RC-10	UAG-II 3073	6.0 in.	525 2.0 4964	153.681	16/03/76
			420 2.0 4966	153.682	16/03/76
RC-10	SAG-II 2007	3.5 in.	520 3.3 3953	88.091	24/02/75
			500 2.2 3434	88.088	30/03/73
			700 2.2 3661	88.122	14/09/70
RC-10	SAG-II 2037	3.5 in.	545 4.4 4537	88.448	24/02/75
RC-10	SAG-II 2061	3.5 in.	525 3.0 4253	88.927	24/02/75

APPENDIX L

THE VARIABILITY OF AEROCHROME INFRARED FILM

The Virtues of Necessity:

Exploiting the Variability
of
Aerochrome Infrared Film

ABSTRACT

Some non-standard descriptive parameters that have been found useful in dealing with the unique attributes of Aerochrome Infrared film are defined. One of these, designated "IR-Balance", has been employed in compilation of a histogram illustrating the range of variability encountered in practice over a three-year period. The manner in which the variability is exploited for high-altitude use by the Airborne Operations Section of the Canada Centre for Remote Sensing is briefly discussed.

L.1 THE VIRTUES OF NECESSITY

The characteristics and applications of Aerochrome Infrared Type 2443 film have been described in the literature of remote sensing and elsewhere.(1,2) Its limitations as a high-altitude sensor have also been recognized and suggestions advanced to compensate for those limitations.(2) An alternative approach may also be available to some users of this unique remote sensing tool who have a particular interest in its high-altitude applications. Some large-volume users of colour infrared film are undoubtedly aware of the possibility of exploiting its variability,(5) but occasional users without access to close sensitometric controls and statistical data may be unaware of the pitfalls of failure to compensate for the variables.

To review briefly, Aerochrome Infrared Type 2443 is a high-contrast, integral tri-pack reversal colour film whose sensitivity to near-IR radiation is deliberately made about 1 1/2 stops less with respect to daylight illumination than the sensitivities of the other two layers to visible red and green light respectively. It is always used in conjunction with a sharp-cutting minus-blue filter such as the Wratten #12 in order to exclude the blue light to which all three layers are sensitive.

The near-IR reflectivity of trees, field crops, and other vegetative cover tends to be closely correlated with plant vigour. Since the high-contrast colour characteristics of the film render variations of IR-reflectivity visible to the photo interpreter long before the effects of stress become apparent to the eye of an observer on the ground, Aerochrome Infrared has become widely used by foresters, agricultural scientists and others who wish to map the areal distribution of insect infestation, disease, moisture or other biological stress.

The difference of sensitivity (i.e. speed) of the layers is illustrated graphically by the typical characteristic curves of Figure 34, in which it may be seen that the curve of the IR-sensitive layer lies to the right of the curves of the other two layers at a distance of approximately 0.35 on the Log E scale. A film with the

characteristics illustrated by Figure 34 works well at ground level or from low altitude. In this range, the excess of reflected IR radiation from healthy deciduous foliage is sufficient to reduce the cyan dye concentration in the IR-sensitive layer below that required for neutral rendition, so that variations in the intensity of radiation reflected from objects of high IR-reflectance (e.g. deciduous foliage) become apparent as variations in the degree of red saturation in their images.

With increasing altitude, however, the ratio of reflected IR to visible radiation is reduced, by absorption of IR and by increased upward scattering of visible light in the longer atmospheric optical path between the aerial camera and the ground. (2) Although the rate of change of the ratio with altitude is not precisely predictable, being a function of both path length and water-vapour concentration, it becomes desirable to increase the IR sensitivity of the film relative to the sensitivity to visible radiation if one wishes to achieve a high-altitude result comparable to that obtainable from low altitudes.

L.2 DESCRIPTIVE PARAMETERS

At this point it is necessary to define certain ad hoc descriptive parameters that the author has found helpful in dealing with the unique attributes of Aerochrome Infrared film. Because of the uniqueness of the material there are no widely recognized standard procedures for determination of film speed, colour balance, etc. An attempt has been made to adhere reasonably closely to an ANSI standard, with the object of achieving numerical values of film speed consistent with use of exposure photometers or other auxiliary equipment calibrated in accordance with standard criteria, as well as permitting valid comparisons with more familiar materials to which existing standards are directly applicable.

L.3 FILM SPEED

There is available to date no standard procedure for the determination of the effective speed of aerial colour

films in general, nor for determining the speed of colour infrared film in particular. The nearest thing appears to be ANSI Standard PH.2.21-1972 (4) which is applicable to reversal colour films. The effective speed of Aerochrome Infrared is therefore determined from the characteristic curves in accordance with the criteria specified by the above standard, and is designated EAFS. The average value of film speed so determined for Aerochrome Infrared is about ASA 50.

L.4 VISIBLE SPEED AND IR SPEED

Since Aerochrome IR includes one IR-sensitive layer which is deliberately made slower than the other two layers whose speeds are more nearly equal, it has been found useful to determine one speed value for the IR-sensitive layer AFS(ir) and another composite speed value AFS(vis) representing the mean speed of the red and green sensitive layers.

Film speed is usually expressed as a simple inverse function of the exposure required to produce a specified level of density under specified conditions; i.e.

$$S = k/E$$

where E is exposure in lux secs. and K is a constant selected to meet some specified condition.

Hence the visible-speed and IR-speed have been defined as follows:

$$\text{AFS(vis)} = 4.72/E(\text{vis})$$

where E(vis) = value of E midway between the green and blue curves at D=1(*)

and:

$$\text{AFS(ir)} = 10.4/\text{E(ir)}$$

where E(ir) = value of E where the red curve intersects $\text{D}=1(*)$

(*) D = Status A integral diffuse density.

L.5 IR-BALANCE

The horizontal separation between the two points referred to above has been designated "IR-balance" (Ref. Figure 34) and appears to be a key parameter for use in categorizing Aerochrome Infrared emulsions as to their suitability for use at various altitudes. For convenience the decimal point is ignored -- e.g., a separation of 0.35 log units is expressed as an IR-balance of 35.

L.6 CHOICE OF CONSTANTS

The constants 4.72 and 10.4 respectively were selected so that the numerical values of EAFS , AFS(vis) and AFS(ir) will all be equal when the IR-balance is 35. An Aerochrome infrared emulsion which exhibits such a value of IR-balance is designated "normal" for several reasons:

1. It conforms closely to the manufacturer's published data.
2. It produces excellent imagery at ground level and from low altitudes.
3. A significant proportion of the emulsions tested to date fall in that category.

L.7 ENHANCEMENT OF THE IR SENSITIVITY

Enhancement of the relative IR-sensitivity may be accomplished by reducing the length of the IR-balance vector, either by shifting the IR curve to the left (IR enhancement) or by shifting the other two curves to the right (visible attenuation).

L.8 RELATIVE IR ENHANCEMENT BY VISIBLE ATTENUATION

Enhancement of the relative IR sensitivity by means of "minus-visible" filtration has been advocated as a practical means of achieving high altitude results on Aerochrome IR film that compare favourably with those obtainable from low altitudes. (2) It is an effective expedient if one can afford the concomitant loss of effective film speed from the added filters, which may be as much as two full stops at 35,000 feet; and it may be the only expedient available to those who must work with a limited supply of Type 2443 emulsion.

The set of characteristic curves designated "a" in Figure 35 illustrates the effect of exposing a normal Aerochrome Infrared emulsion through a CC 40 Blue filter in conjunction with the usual Wratten #12 "minus-blue" filter. The Wratten #12 plus CC 40B combination represents "minus-visible" filtration which attenuates the visible portion of the spectrum while allowing almost unimpeded transmission of the near infrared, since both filters have infrared windows. Note the loss of effective film speed amounting to a full stop, as a consequence of having to apply a filter factor.

When one attempts to use Aerochrome Infrared film in a wide-angle or super-wide-angle aerial survey camera in which lens speed and uniformity of focal plane illumination have had to be sacrificed in favour of minimum geometric distortion and maximum resolution, the loss of effective film speed as a consequence of IR-balancing filtration presents a serious limitation.

The best modern super-wide-angle lenses limit the maximum radial distortion to less than 10 μ m across a field

of view of up to 125 degrees, but this is accompanied by severe vignetting at the maximum aperture of F/4 which reduces illumination of images in the corners of the format to about 20% of that available at the principle point. To counteract the effects of the severe off-axis illumination fall-off, a heavy anti-vignetting filter is employed having an axial attenuation factor of 4.4X -- i.e., at a penalty of more than two stops in effective speed of the central portion of the field. The further loss of up to two more stops due to use of "minus-visible" filtration leaves one with a rather slow-speed aerial photographic system that is seriously limited with respect to season and time of day when acceptable photography may be secured from high altitudes on Aerochrome Infrared film with a super-wide-angle camera.

L.9 REAL IR ENHANCEMENT BY SELECTION

A more attractive approach to IR-enhancement for high altitude use lies in the possibility of improving the IR-balance by a genuine increase in the speed of the IR-sensitive layer -- i.e., by moving the IR curve to the left, rather than by moving the other curves to the right by using absorption filters involving a filter factor. (e.g., See characteristic curves designated "B" in Figure 35.)

There is no magic formula for increasing at will the sensitivity of any given layer of a multi-layer film. However, analysis of many rolls of Aerochrome Infrared Type 2443 film has indicated that in many cases the IR-sensitive layer is significantly faster than in the case of "normal" film. Using the descriptive parameters defined earlier, the sensitometric data from several hundred rolls of Aerochrome IR film, representing many different emulsion batches, have been analysed and the emulsions categorized according to IR-balance. A rather surprising range of IR-balance has been encountered, from a minimum value of 10 to a maximum greater than 50. The frequency distribution of IR-balance among rolls exposed by the Canada Centre for Remote Sensing over the past three operating seasons is illustrated by the histogram of Figure 36. Fortunately, most of the departures from "normal" are in the direction of enhanced IR-sensitivity which can be exploited for high altitude use.

L.10 APPLICATION TO CCRS OPERATIONS

Stocks of Aerochrome Infrared Type 2443 film held in cold storage by CCRS are subjected to periodic testing and categorization on the basis of IR-balance, by sensitometric analysis of representative samples of all emulsion numbers on hand, and occasionally on specific rolls for specific purposes. Those emulsions categorized as "IR-enhanced" are reserved for high-altitude use, or for other applications requiring more nearly equalized layer sensitivities. Emulsions in the "normal" category are used at low altitudes -- i.e., up to 3,000 feet -- without modification, or at higher altitudes only with appropriate "minus-visible" filtration.

The very small number of the "IR-degraded" category must be brought into normal balance, usually requiring CC magenta filters, before use at any altitude. Altitude-compensating filtration is then added as necessary, but the overall filter factor which results generally rules out the use of "IR-degraded" emulsions in super-wide-angle cameras.

The roll-to-roll variability of IR-balance of a given emulsion number has been found to be gratifyingly small. In the case of fresh film, stored at -18 degrees C. and handled with all reasonable care, it is likely that the IR-balance can be maintained within +/- 3 units of the mean value for that emulsion throughout an entire operating season.

In the case of emulsions that have been held in storage for up to three years, the range of variability is greater and a slow drift in the direction of degraded IR-sensitivity is detectable in the sensitometric data from periodic re-checks. However, these data enable us to specify compensating filtration if necessary to ensure a greater degree of consistency in the output of Aerochrome Infrared imagery at all altitudes.

L.11 INSTRUMENTATION

All sensitometric data are based on measurement of step-wedges exposed in a sensitometer designed and calibrated by the National Research Council of Canada, meeting the requirements of the ICAS Specification for Aerial Survey Photography, 1973.(6) The illuminant is standard air photo daylight(7) and the effective exposure time is 1/118 second.

Densities are measured on a controlled photo-electric densitometer, fitted with a Status A filter turret.

All films are processed under close control by the Reproduction Centre of the National Air Photo Library in a Kodak RT 1811 continuous processor using EA5 chemistry. Process control is independent of the sensitometric wedges printed on all operational rolls of film.

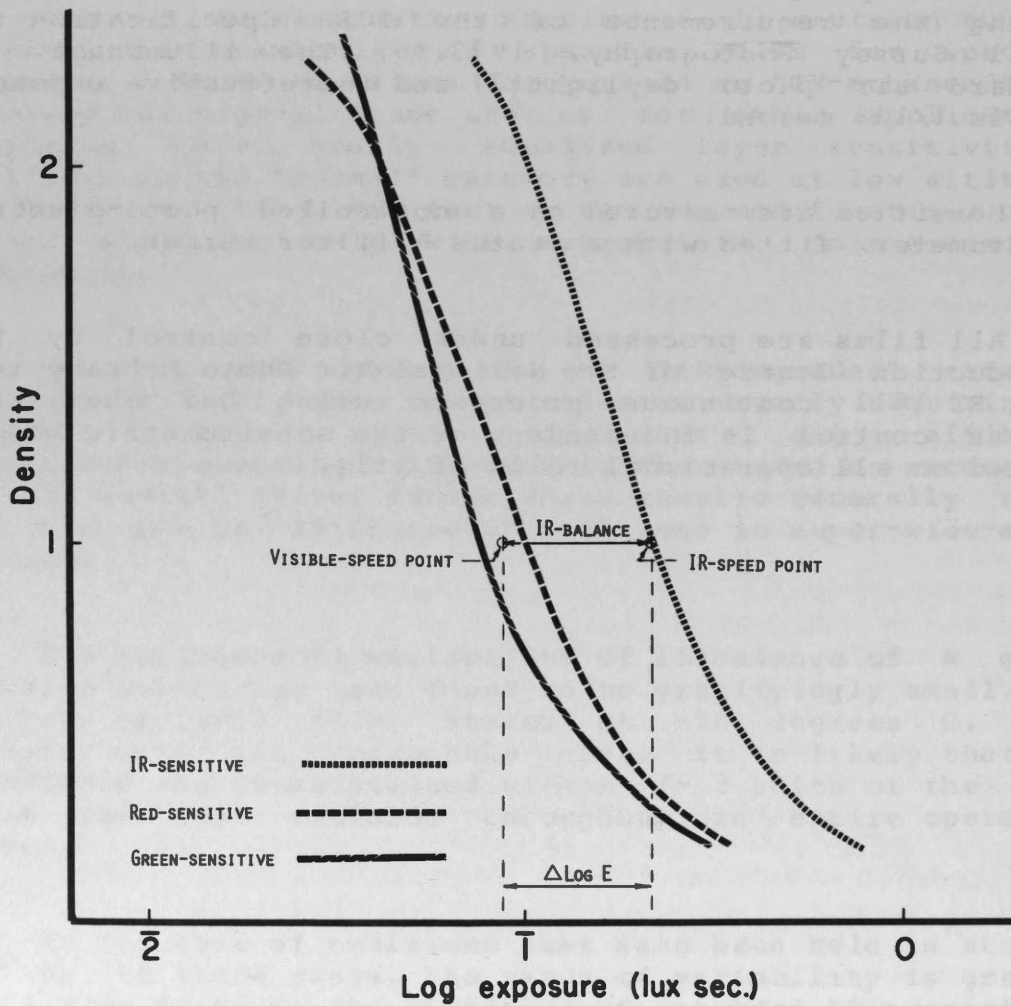

Figure 34 -- Typical characteristic curves of Aerochrome Infrared Type 2443 film of "normal" IR-balance; i.e. the length of the IR-balance vector is approximately 0.35 on the Log E scale.

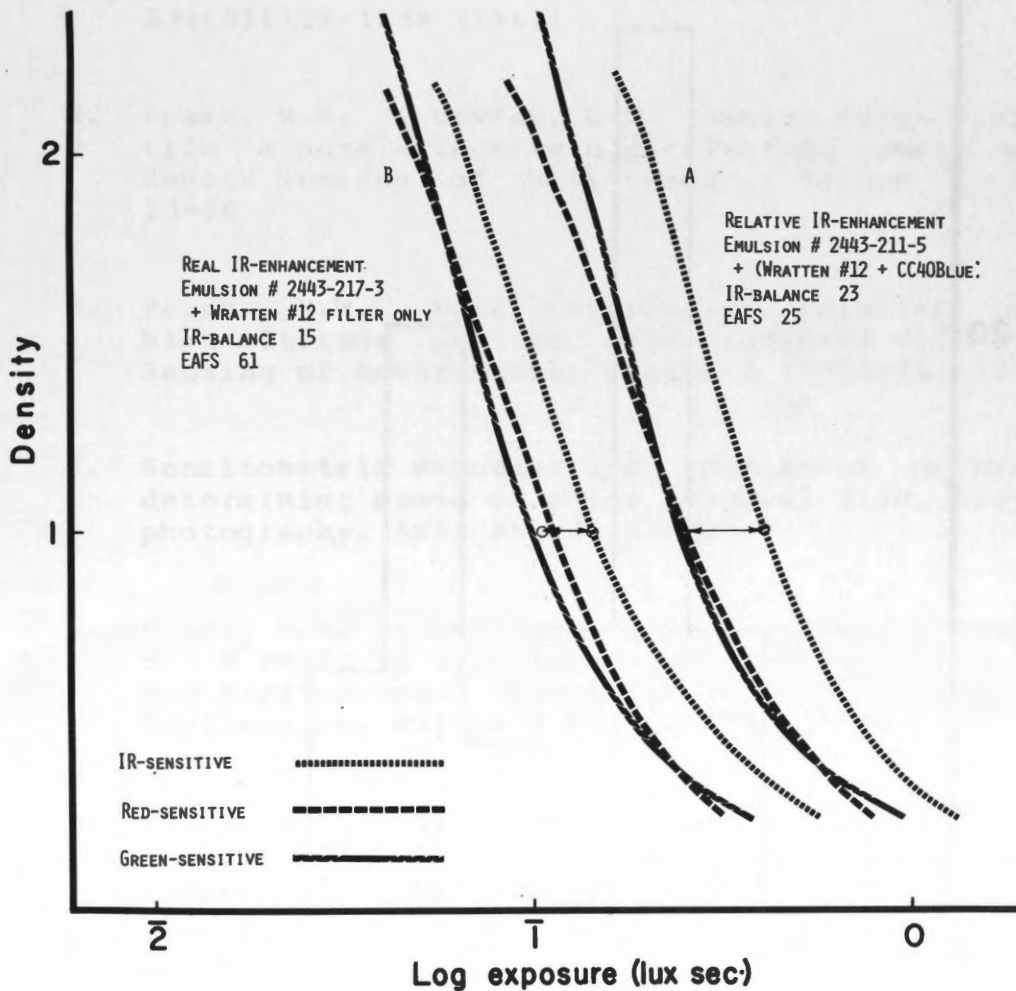

Figure 35 -- (a) Curves of a "normal" emulsion whose relative IR-sensitivity has been enhanced by "minus-visible" filtration for use at about 10,000 feet, at a considerable penalty in effective film speed.
(b) Curves of a selected "IR-enhanced" emulsion considered suitable for use at about 20,000 feet without additional filtration and with no loss of effective film speed.

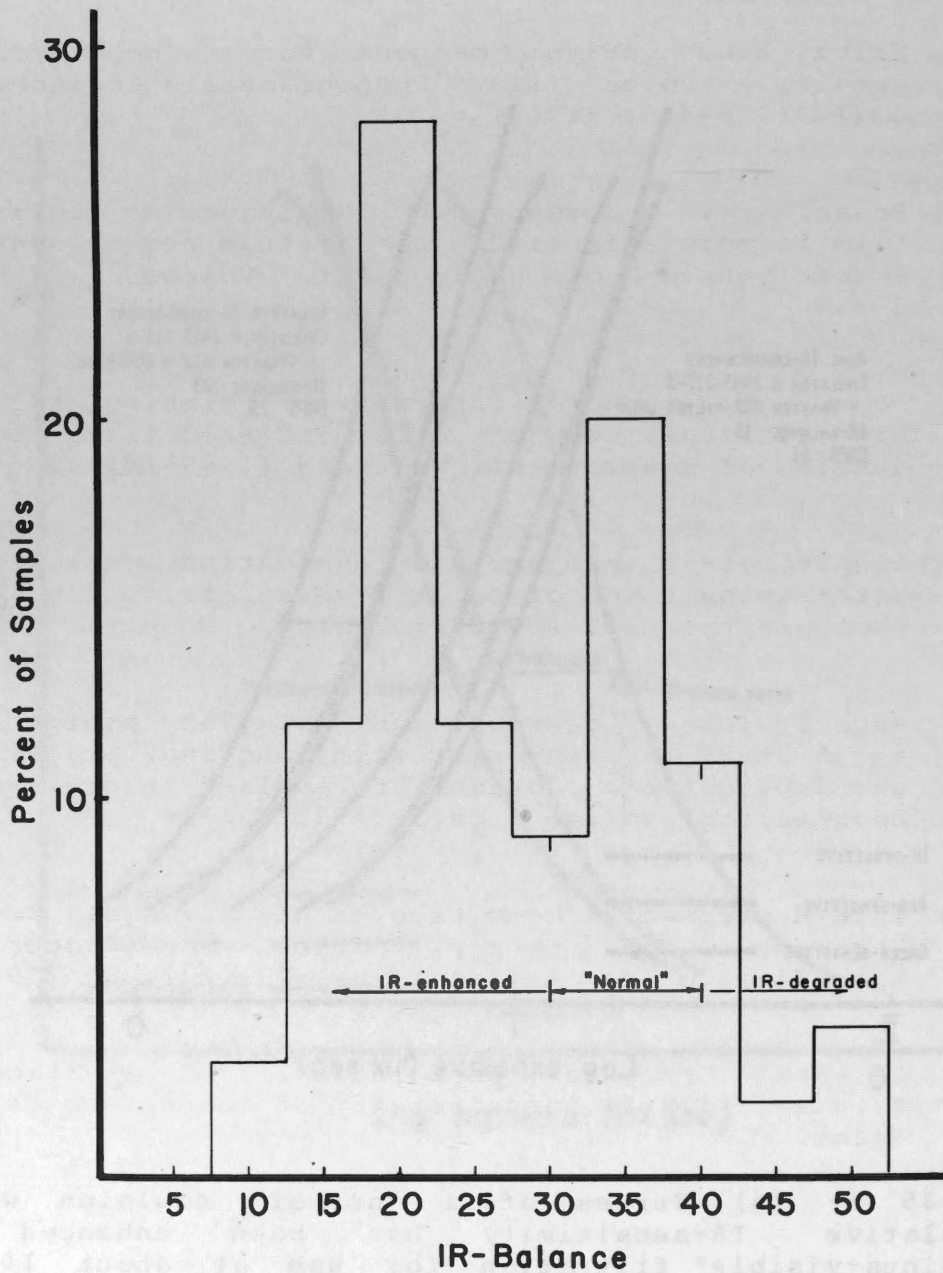

Figure 36 -- Histogram illustrating the range of IR-balance encountered by CCRS Air. Ops. over the 1974-75-76 operating seasons. More than 200 rolls of 9 1/2 inch Aerochrome Infrared and more than 20 different emulsion numbers are represented. (70 mm film not included)

L.12 REFERENCES

1. Fritz, N.L. Optimum methods for using infrared sensitive color film, Photogrametric Engineering 33(10)1128-1138 (1967)
2. Pease, R.W. & Bowden, L.W. Making color infrared film a more effective high-altitude remote sensor. Remote Sensing of Environment, Volume 1 (1969) 23-30
3. Pease, R.W. More information relating to the high-altitude use of color infrared film, Remote Sensing of Environment, Volume 1 (1969-70) 123-126
4. Sensitometric exposure and evaluation method for determining speed of color reversal film, for still photography, ANSI PH2.21 (1972)
5. Sauer, G.E. & Lockwood, H.E. Skylab photography -- A study in zero-error film handling, processing and duplication. Journal of Applied Photographic Engineering, Volume 1, Fall (1975) 18-24
6. Interdepartmental Committee on Air Surveys, Canada Department of Energy, Mines and Resources, Specification for Aerial Survey Photography (1973)
7. Canadian Standards Association. CSA Standard Z7.3.2.1 (1969) Sensitometry of Monochrome Aerial Films

LIBRARY REFERENCE

1. Latta, R.L. Optical methods for determining the refractive index of solids. *Journal of Optics*, 1967, 1(1), 1-12.
2. Latta, R.L. Optical methods for determining the refractive index of solids. *Journal of Optics*, 1967, 1(1), 1-12.
3. Latta, R.L. Optical methods for determining the refractive index of solids. *Journal of Optics*, 1967, 1(1), 1-12.
4. Latta, R.L. Optical methods for determining the refractive index of solids. *Journal of Optics*, 1967, 1(1), 1-12.
5. Latta, R.L. Optical methods for determining the refractive index of solids. *Journal of Optics*, 1967, 1(1), 1-12.
6. Latta, R.L. Optical methods for determining the refractive index of solids. *Journal of Optics*, 1967, 1(1), 1-12.
7. Latta, R.L. Optical methods for determining the refractive index of solids. *Journal of Optics*, 1967, 1(1), 1-12.

1967-68
 1968-69
 1969-70
 1970-71
 1971-72
 1972-73
 1973-74
 1974-75
 1975-76
 1976-77
 1977-78
 1978-79
 1979-80
 1980-81
 1981-82
 1982-83
 1983-84
 1984-85
 1985-86
 1986-87
 1987-88
 1988-89
 1989-90
 1990-91
 1991-92
 1992-93
 1993-94
 1994-95
 1995-96
 1996-97
 1997-98
 1998-99
 1999-00
 2000-01
 2001-02
 2002-03
 2003-04
 2004-05
 2005-06
 2006-07
 2007-08
 2008-09
 2009-10
 2010-11
 2011-12
 2012-13
 2013-14
 2014-15
 2015-16
 2016-17
 2017-18
 2018-19
 2019-20
 2020-21
 2021-22

INDEX

ADAS	106
Aerocolor 2445 film	68
Airborne Operations Section	13
Airborne Sensing Unit	14
Aircraft	9, 31 to 43
Altitudes	19
Application and objectives	17
Area of operation	18
Balloon	42 to 43
C-GRSA	34 to 36
C-GRSB	31 to 33
C-GRSC	40 to 41
C-GRSD	37 to 39
Calibrated focal length	K-4
Cameras	9, 44 to 47, K-4
Cameras super-wide	C-1 to C-6
Charges	
applicable	86
line mile	86
material	87
processing	87
reproduction	87
Communications	17
Convair	40 to 41
Cost estimating	F-1 to F-3
Cost recovery	85 to 89
Costing	10
Costing	
line mile	10
processing	10
reproduction	10
Coverage	B-1 to B-19
CW laser fluorosensor	95
Daedalus	51 to 53
Daedalus processing	53 to 61
Dakota	31 to 36
Data	10

Data Acquisition Division . . .	12
Data retrieval	90
Delivery	23
Detectors	K-2
Double-X 2405 film	65
Ektachrome 2448 film	66 to 67
Electromagnetic spectrum . . .	K-2
Exotech ERTS radiometer . . .	62
Falcon	37 to 39
Film	9, 64 to 71
Film annotation	G-1 to G-8
Filters	9, 72 to 81
Finalization	25
Fiscal year 1977/78	89
Flight completion	27
Focal length	K-4
GASPEC	103
GRAMS	107
Hasselblad	47
Image motion tables	D-1 to D-9
Inertial navigation system . . .	109
Infrared 2424 film	66
Infrared 2443 film	69 to 70, C-2, K-3, L-1 to L-13
Infrared radiometry	J-1 to J-8
Innotech Aviation Limited . . .	13 to 14
Interra	14
Introduction	9 to 11
Invoicing	29
Lenses	9
Liason	25
Lidar bathymeter	96
Linear detector array spectrometer	98
Low light level TV	104
Map sheets	18
Material	9, 21
MEIS	102
MPPH four barrel photometer . .	99
Multispectral line scanner . . .	101
NAPL price list	A-1 to A-5
National Air Photo Library . . .	14
Notification	26

Overlap	20
Percent cloud	20
Photometer	62
Plus-X 2402 film	64
Primary sensor	20
Priorities	21 to 23
Processing	27
PRT-5	48
PRT-6	48 to 49
Pulsed laser fluorosensor	93
Quality control	13, 27
Radiometer	49 to 50, 62
Radiometry	J-1 to J-8
RC-10	46 to 47
RC-8	45
Regional centres	I-1 to I-3
Regional committees	16
Reports	91
Reproduction	21 to 22, 28
Reproduction	
characteristics	C-3
secondary	23
Reproduction centre	15
Request	
approval	25
examination	24
procedures	17
submission	16 to 30
Request sheet	H-1 to H-3
Requests	10, 13
Revisions	26
Scale	B-1 to B-19
Scanner	51 to 61
Scatterometer	92
Scheduling	26
Sensor platforms	31 to 43
Sensor section	12
Sensors	9, 21, 44 to 63, 92 to 98, 100 to 105
Sensors	
future	92 to 105
photographic	9, 44 to 47, K-4
Sequence of events	24
Shipment	29
Solar noon	E-12
Solar noon correction	E-13

Sun angle	19
Sun angle tables	E-1 to E-13
Systems	99, 105 to 110
Systems	
future	105 to 110
Systems section	13
Task sheet	H-1, H-4 to H-7
Tasking	26
Tektronix J16 photometer	62
Time periods	18
Transmittance	
Convair camera hatch	84
DC-3 camera hatch	82
Falcon camera hatch	83
User calculations	88
Vinten	44
Visual library	90 to 91
VLF navigation system	110

