

This document was produced  
by scanning the original publication.

Ce document est le produit d'une  
numérisation par balayage  
de la publication originale.

ERL/CAT 87/88 031

PETROLEUM SOCIETY OF CIM

PAPER NO. 15

THIS IS A PREPRINT — SUBJECT TO CORRECTION.

# OILFIELD PRODUCED WATER TREATMENT BY ULTRAFILTRATION

by  
Brian Farnand  
Energy Mines and Resources, Canada  
Tom Krug  
Zenon Environmental Inc.

## PUBLICATION RIGHTS RESERVED.

THIS PAPER IS TO BE PRESENTED AT THE FIRST ANNUAL TECHNICAL MEETING OF THE SOUTH SASKATCHEWAN SECTION, THE PETROLEUM SOCIETY OF CIM, HELD IN REGINA, OCTOBER 6 - 8, 1987. DISCUSSION OF THIS PAPER IS INVITED. SUCH DISCUSSION MAY BE PRESENTED AT THE TECHNICAL MEETING AND WILL BE CONSIDERED FOR PUBLICATION IN CIM JOURNALS IF FILED IN WRITING WITH THE TECHNICAL PROGRAM CHAIRMAN PRIOR TO THE CONCLUSION OF THE MEETING.

### ABSTRACT

A study was undertaken to investigate the treatment of oilfield produced water by ultrafiltration in order to remove the oil to make steam generator quality water. To simulate commercial operation, tubular membranes were used in ultrafiltration experiments along with samples that were shipped quickly and directly from oil producers' sites in Western Canada. Permeation rates, oil content, degree of recovery, and other results were monitored at various operating conditions for several produced water samples. It was observed that the more stable produced waters are more amenable to treatment by ultrafiltration than destabilized produced waters. This reduces the amount of water treatment chemicals and in combination with the complete removal of oil, provides a stable and clean feed to subsequent softening and other water treatment operations. Other factors including membrane fouling by the oil and membrane operations at unusually high temperatures were investigated.

### INTRODUCTION

Steam stimulation of oil wells in the arid regions of Western Canada requires large volumes of water for steam generation and subsequent injection into the formation. When the oil is recovered from the formation, the steam that has condensed into water is pumped from the wellhead in combination with the oil. Recycling of this produced water to steam generator quality is difficult since it is contaminated with heavy oil, large amounts of dissolved inorganic salts, and silica. The economics and environmental advantages of recycling the produced water are expected to improve as overall water demand increases, thus providing increased incentives to treat produced water.

The wellhead fluid from a typical steam flood recovery operation may contain 2 to 10 barrels of water per barrel of oil product, part as a water-in-oil emulsion and part as the reverse emulsion. The first treatment is usually a free water knockout (FWKO) followed by high temperature settling (HTS) of the oil rich FWKO effluent. The water rich effluent from these two

ERL/CAT 87/88 031

operations is described as produced water and is further treated in a skim tank to remove residual oil. The water from the skim tank is often disposed of by deep well injection or can be treated further for recycle to the steam generator. Several Canadian producers currently recycle produced water using a combination of conventional treatment and oil removal processes. Not only do the steam generator specifications require complete removal of the oil, most water softening and silica reduction treatment units require the removal of oil for optimal operation. This usually results in the use of oil removal with induced gas flotation (IGF) and sand filtration units and the addition of large amounts of emulsion destabilizing chemicals.

Cross flow ultrafiltration (UF) processes have been demonstrated for the efficient and economical treatment of industrial waste streams containing oils such as cutting oil from metal machining operations. Since UF is a cross flow filtration and free of filtration cakes and backwash procedures, it can handle higher oil levels than sand filtration. For this reason UF can be considered for replacing IGF units and its high level of water recovery will reduce the water load on the skim tank. As well, UF provides an absolute barrier to the oil which results in a higher quality filtrate than sand filtration and does not have oil breakthrough even during process upset conditions. This reduces the need for oil determination instrumentation, and provides an oil-free feed to ion exchange operations that are sensitive to oil plugging.

#### EXPERIMENTAL

Developmental work with UF processing of oily water is described elsewhere<sup>1</sup>. The experimental results generated by this work were performed with samples of produced water from FWKO and HTS units from several sites in Western Canada. The samples were shipped directly from the producer to the experimental site, and were received within two or three days of shipping. Thirteen experiments of approximately one to two weeks duration were performed on samples from eight enhanced oil recovery (EOR) sites.

The membranes used in these experiments were 1.27 cm diameter Zenon Environmental CHP-TFC (thin film composite) tubes that were chosen based on their fouling resistance in previous experiments. The tubes were mounted serially and had a total surface area of

182 cm<sup>2</sup>. A schematic of the experimental apparatus is shown in Fig. 1. The experiments were performed by initially concentrating the produced water by a factor of 10 (90% recovery) and subsequently recycling the permeate into the feed reservoir for the duration. The operating temperature was 65°C, the operating pressure was 690 kPa (gauge) and the circulation rate was suitable to produce a Reynold's number in the 30,000 range. As their permeation rates decreased, the membranes were cleaned by methods developed for industrial oil separation membrane processes with some modification for the heavy oils and bitumen in the produced water.

The results of the experiments are summarized in Table 1. As with previous experiments on the UF of produced water, the permeates were free from oil, crystal clear and had hardness, silica and total dissolved solids in the same range as the original sample. The permeation results indicate that the membrane performance is source specific and the performance could be related to the condition of the reservoir during the experiment. Where lower permeation rates occurred there was evidence of free oil floating in the reservoir tank. This suggests the oil-in-water (o/w) emulsion was not stable. For the higher permeation rates, there was no evidence of free oil in the reservoir, suggesting a more stable o/w emulsion. Experience with industrial oily water separations with membranes has shown that stable o/w emulsions have higher permeation rates, and our results concur. The basis for this sensitivity to the stability of the o/w emulsion is that the membrane is not subject to as severe a gel formation at the membrane surface where the emulsion is stable enough to resist oil agglomeration during the selective removal of water.

#### PROCESS ECONOMICS

The experimental results were used to compare the costs of treating produced water by conventional methods and with UF. The design basis is the same as that given previously<sup>2</sup> for an 80% boiler of 73 MW (250,000 BTU/h) requiring a feed of 1890 m<sup>3</sup>/d (500 000 US gallons per day) of recycled produced water. The comparison includes only the processing required to reduce oil to acceptable levels for the subsequent operations of hot lime softening and ion exchange.

A schematic of the conventional process is described in Fig. 2. FWKO and HTS produced water is fed into the skim tank after addition of chemical emulsion breakers. An oil skim is removed, the water rich effluent is treated with

190 5878 FA 3/5/83

chemicals, then passed into an IGF unit. An oil froth is skimmed from the IGF and after adding chemical emulsion breakers, the produced water is sent to a sand filter. The sand filter produces a filter backwash suitable for sludge disposal, then the filtered water is sent for softening. The capital and operating costs for each operation were determined by cost correlation, manufacturer's quotations, and actual operational experience. These are outlined in Table 2, and include installation costs such as foundations, instrumentation, piping, and construction expenses and operational costs such as electrical power and emulsion breaking chemicals.

A flow schematic of the UF process equipment is shown in Fig. 3. It is assumed that the process was operated at a continuous 90% recovery and that the concentrate could be recycled to recover the oil in either the FWKO or the HTS unit. The costing of the UF process equipment is outlined in Table 2 for three types of module designs and for three permeation rates. The capital costs include the installation costs as outlined above, and the operating costs include cleaning every two weeks and membrane replacement every two years. The three types of module designs were chosen based on commercially available tubular membrane modules of high capital cost and low membrane tube replacement cost, disposable tubular membrane units of intermediate capital cost, and near-commercial disposable small tube membrane modules of lowest capital cost. The capital cost for the latter unit was estimated based on similar commercial equipment and assuming that the fouling resistant membranes used in this work can be accommodated in similar units.

Annual costs amortized over 10 and 5 years are also included in Table 2, and graphical interpretations of the annual costs are shown in Figures 4 and 5. These calculations demonstrate that UF processing of produced water is competitive with conventional processes for permeation rates in excess of  $3.0 \text{ m}^3/\text{m}^2/\text{d}$  for even the highest capital cost membrane modules. It is also apparent that the permeation rate through the membranes is the controlling factor for the economic evaluation of the membrane process.

#### DISCUSSION

Factors being considered to improve the economics of the UF process are concerned with reducing its capital cost. The permeation rate has been observed to increase as much as 30% when the produced water's pH is increased from its as

received value of approximately 7.5 to 9.0 by adding NaOH. The reduction in the pH of the produced water causes dissociation of the acidic components of the oil, and increases their surfactant properties. This in turn causes a stabilization of the produced water with a subsequent increase in the permeation rate. Another consideration is to reduce the operating pressure to 350 kPa (gauge). This reduces the permeation rate, but permits the use of less expensive pumps and reduces the capital cost of the membrane module fabrication. It may also reduce the cleaning requirement since the dewatering effect in the region of the membrane will be reduced and the o/w stability will not be as severely challenged. Several results from experiments with these modified operating conditions are included in Table 1. Increasing the pore sizes of the membranes is also being considered, but this may lead to the passage of water soluble organic compounds which may cause problems with the softening operations. Operation of the UF process at  $85^\circ\text{C}$  has been investigated and this has also resulted in an increase in the permeation rate by reducing the viscosity of the water.

Other work is being considered regarding the longer term operation of the UF experiment. Actual operation at an oil producers' site is required to determine whether limitations exist for the UF process during the daily operation of the water recovery stream. Longer term operation will permit a better estimate of the lifetime of the membranes, and the requirement for cleaning. Another consideration that may improve the UF process is the mode of operation. The experiments reported in this work simulate continuous operation at 90% recovery in a 'feed and bleed' operation. Experience with other operations with oily water indicate that batch operation (recycle of the membrane treated produced water to the reservoir without the addition of fresh produced water) may improve the permeation rates, since gel fouling at the membrane surface will be less at the beginning of the batch and will approach the 90% recovery case only at the end of the batch. Large amounts of produced water are needed to demonstrate this operation, which would require the cooperation of an oil producer.

#### CONCLUSIONS

UF can be used to remove the oil from produced water at less cost than conventional treatment. The major requirement is that the permeation rate at 90% recovery be in excess of  $3 \text{ m}^3/\text{m}^2/\text{d}$  at  $65^\circ\text{C}$  and 690 kPa (gauge)

operation. Experimental results have shown that this permeation rate is exceeded for several cases. Other experimental results show that the permeation rates can be improved by higher operating temperatures and increasing the pH of the produced water thereby increasing its stability.

#### ACKNOWLEDGEMENT

The authors wish to acknowledge Energy, Mines and Resources Canada for funding this work and they wish to thank the oil producers who cooperated by providing samples and advice.

#### REFERENCES

1. Zenon Environmental Inc. (1987)  
"Membrane Processing of Oilfield Produced Water for Enhanced Oil Recovery (EOR) Steam Generation", Report Prepared for Energy, Mines and Resources Canada, CANMET.
2. CH2M-HILL Canada Ltd. (1982)  
"Generation of Steam Using Low-Grade Fuels and Field Produced Water for In-Situ Oil Recovery", Report Prepared for Energy, Mines and Resources Canada, CANMET.

TABLE 1

ULTRAFILTRATION PERFORMANCE FOR VARIOUS SITES AND CONDITIONS<sup>a</sup>

<u>Site</u>	<u>Source</u>	<u>Oil ppm</u>	<u>Silica ppm</u>	<u>Hardness ppm</u>	<u>TDS ppm</u>	<u>Permeation m<sup>3</sup>/m<sup>2</sup>/d</u>	<u>Duration h</u>
1	FWKO	640	79	1000	13200	3.5	60
1	SKIM	78	122	1285	14000	5.0	140
2	WELL	1120	188	149	7410	1.6	120
2	IGF	890	171	890	7630	1.3	220
2	FWKO +HTS	330	195	97	6200	2.0	110
2	FWKO +HTS	330	195	97	6200	2.0 <sup>b</sup>	70
2	FWKO +HTS	330	195	97	6200	3.0 <sup>c</sup>	60
3	HTS	730	99	1143	12000	1.5	140
4	FWKO <sup>d</sup>	2600	10	3713	45400	5.0	70
5	SKIM	430	137	257	9530	1.1 <sup>e</sup>	25

<sup>a</sup> 690 kPa, 65°C, pH as received, averaged permeation rates

<sup>b</sup> 350 kPa, 75°C, pH 9.0

<sup>c</sup> 350 kPa, 85°C, pH 9.0

<sup>d</sup> Fire flood operation

<sup>e</sup> 350 kPa

TABLE 2

CAPITAL AND OPERATING COSTS<sup>a</sup> FOR OIL REMOVAL FROM PRODUCED WATER

<u>Process</u>	<u>Module Cost</u>	<u>Assumed Permeation m<sup>3</sup>/m<sup>2</sup>/d</u>	<u>Capital Cost</u>	<u>Annual Operating Cost</u>	<u>Annual<sup>b</sup> Cost (10 year)</u>	<u>Annual<sup>b</sup> Cost (5 year)</u>
CONVENTIONAL	--	--	\$1,573	\$434	\$702	\$859
UF	High	4.0	\$1,563	\$221	\$487	\$643
		3.0	\$2,084	\$225	\$609	\$818
		2.0	\$2,932	\$382	\$881	\$1,174
	Med.	4.0	\$1,004	\$254	\$425	\$525
		3.0	\$1,339	\$298	\$526	\$660
		2.0	\$1,884	\$447	\$768	\$956
	Low	4.0	\$814	\$223	\$361	\$443
		3.0	\$1,085	\$257	\$442	\$550
		2.0	\$1,527	\$386	\$645	\$798

<sup>a</sup> \$K(CAN.)

<sup>b</sup> Annual costs at 11% interest, amortized over 10 years and 5 years.

## Flow Schematic for Membrane Test Equipment

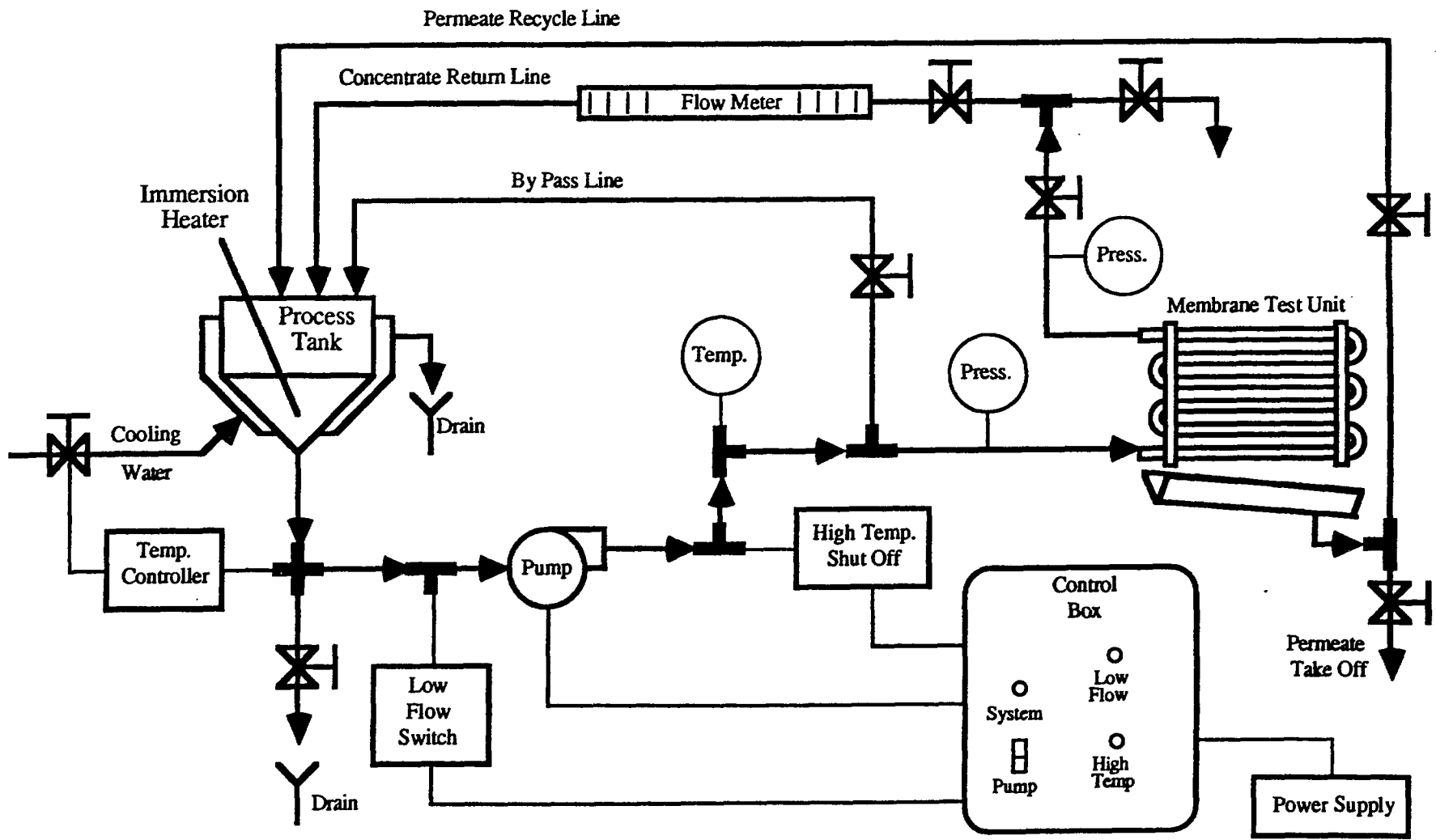

# CONVENTIONAL PROCESS FOR OIL REMOVAL FROM PRODUCED WATERS

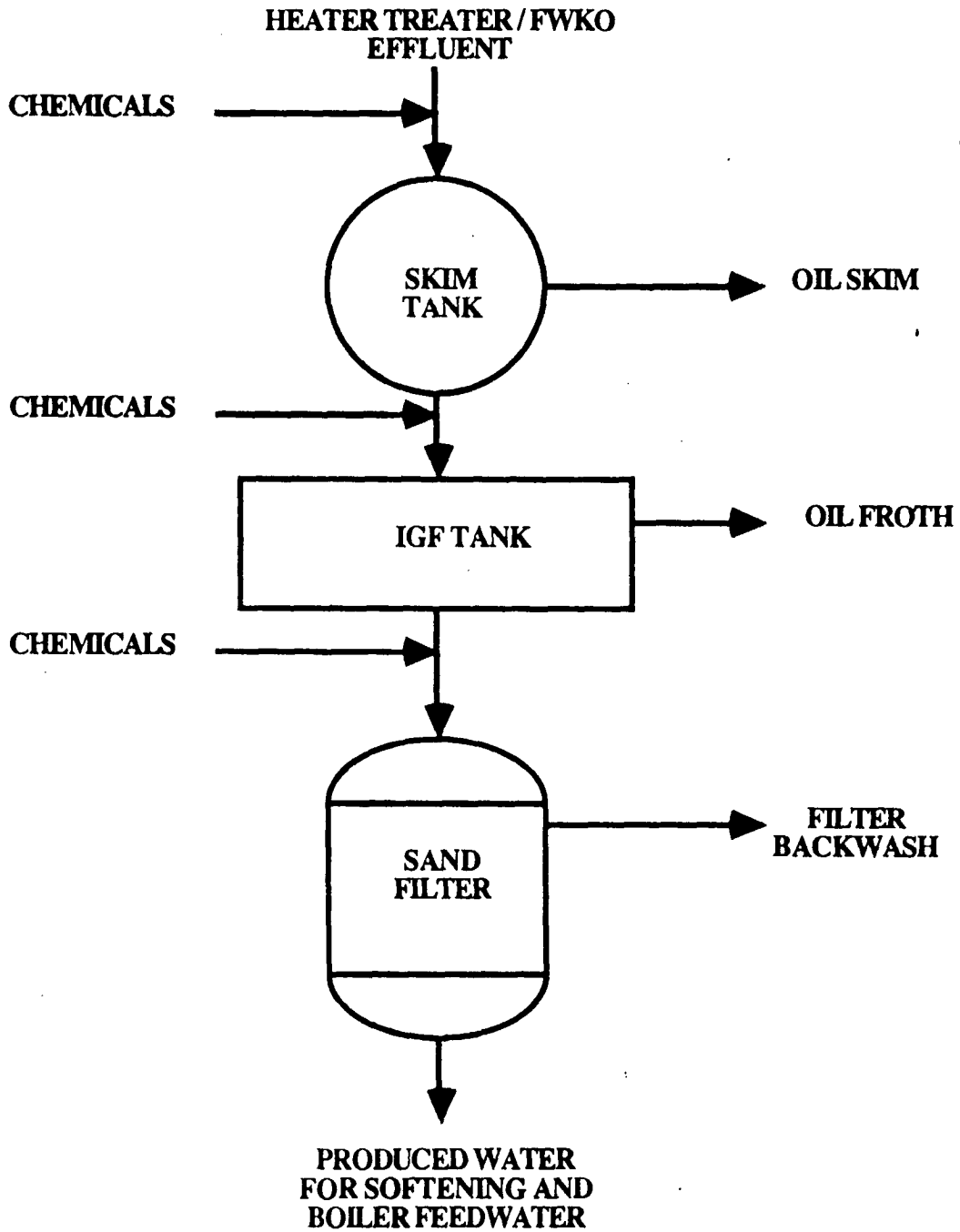



**MEMBRANE PROCESS FOR OIL REMOVAL FROM  
PRODUCED WATERS**

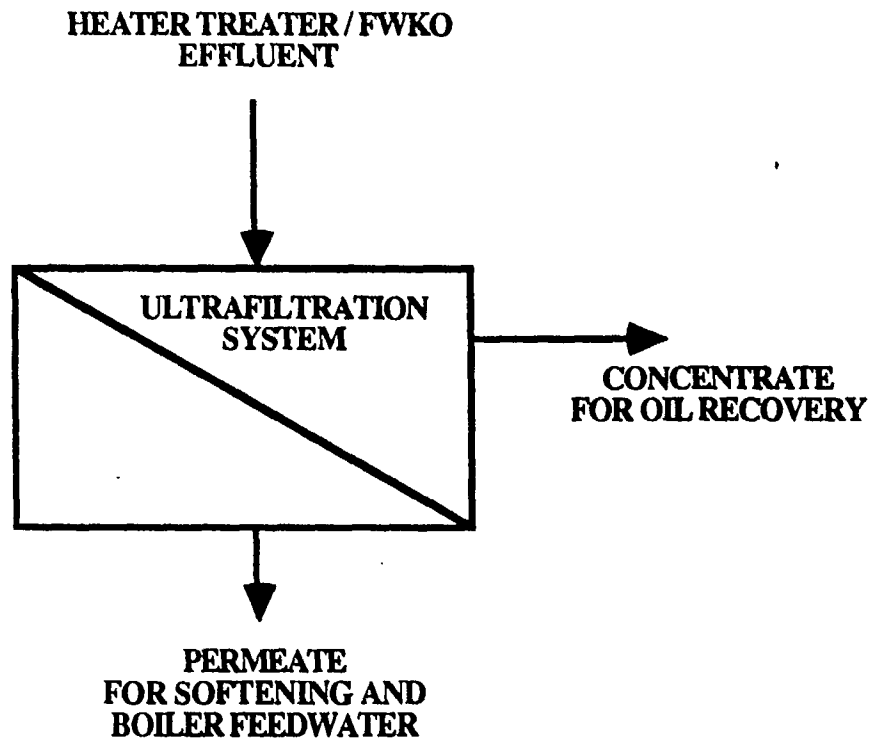

### Yearly Costs for Conventional and Membrane Based Processes for Produced Water Treatment (5 year amortization of capital)

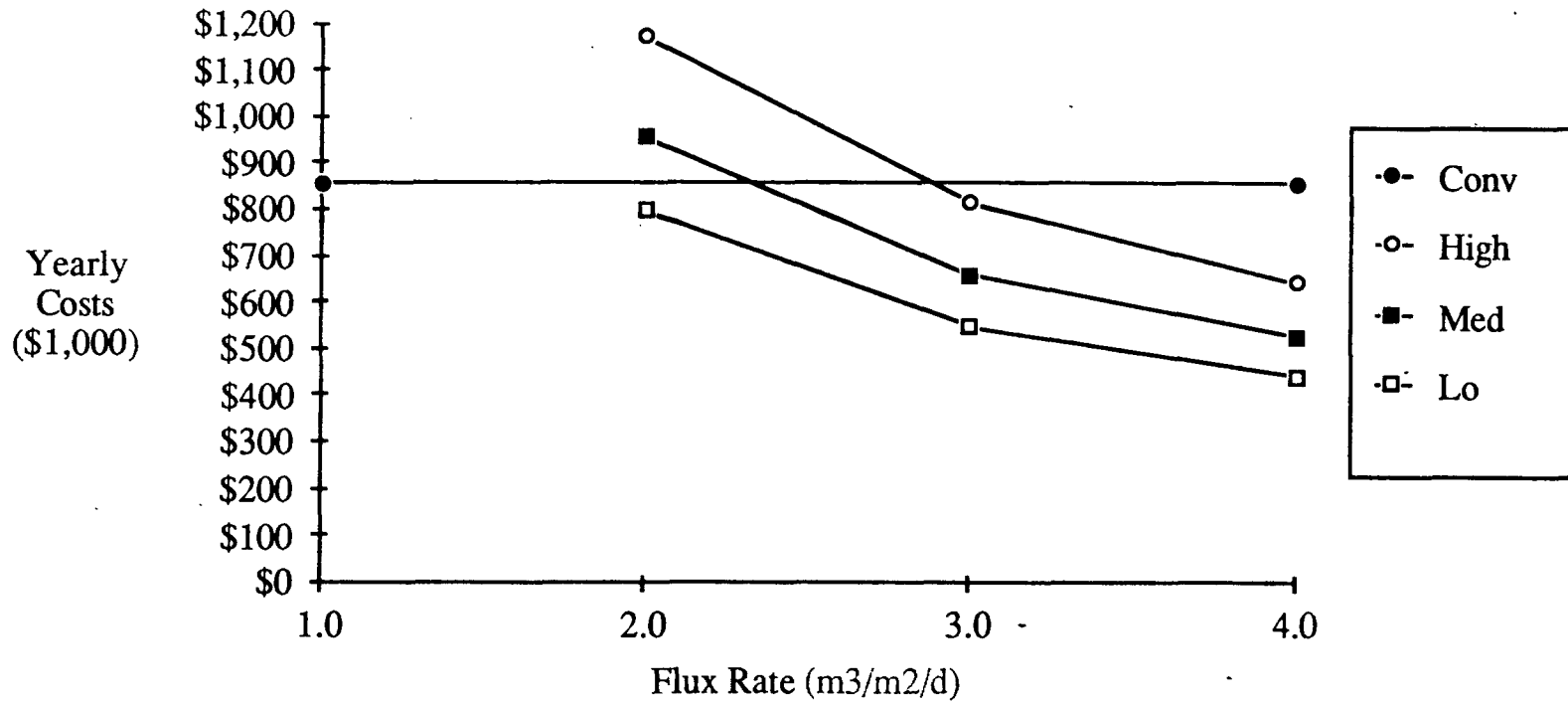

### Yearly Costs for Conventional and Membrane Based Processes for Produced Water Treatment (10 year amortization of capital)

