

ENERGY
MANAGEMENT
SERIES

6

FOR INDUSTRY
COMMERCE
AND INSTITUTIONS

Boiler plant equipment

TJ
163.4
C2
A6
no. 6
c.2

This document was produced
by scanning the original publication.

Ce document est le produit d'une
numérisation par balayage
de la publication originale.



Energy, Mines and
Resources Canada

Energie, Mines et
Ressources Canada

Canada

TJ
163.4
ca
A6
no.6
C.2

PREFACE

Much has been learned about the art and science of managing energy during the past decade. Today, energy management is a seriously applied discipline within the management process of most successful companies.

Initially, in the early 1970's, energy conservation programs were established to alleviate threatened shortages and Canada's dependency on off-shore oil supplies. However, dramatic price increases quickly added a new meaning to the term "energy conservation" — reduce energy costs!

Many industrial, commercial and institutional organizations met the challenge and reduced energy costs by up to 50%. Improved energy use efficiency was achieved by such steps as employee awareness programs, improved maintenance procedures, by simply eliminating waste, as well as by undertaking projects to upgrade or improve facilities and equipment.

In order to obtain additional energy savings at this juncture, a greater knowledge and understanding of technical theory and its application is required in addition to energy efficiency equipment itself.

At the request of the Canadian Industry Program for Energy Conservation, the Commercial and Institutional Task Force Program and related trade associations, the Industrial Energy Division of the Department of Energy, Mines and Resources Canada has prepared a series of energy management and technical manuals.

The purpose of these manuals is to help managers and operating personnel recognize energy management opportunities within their organizations. They provide the practitioner with mathematical equations, general information on proven techniques and technology, together with examples of how to save energy.

For further information concerning the manuals listed below or material used at seminars/workshops including actual case studies, please write to:

Business & Government Energy Management Division
Energy Conservation Branch
Department of Energy, Mines and Resources
580 Booth Street
Ottawa, Ontario
K1A 0E4

- | | |
|--|--|
| Energy Management/Employee Participation | 9 Heating and Cooling Equipment (Steam and Water) |
| Conducting an Energy Audit | 10 Heating Ventilating and Air Conditioning |
| Financial Analysis | 11 Refrigeration and Heat Pumps |
| Energy Accounting | 12 Water and Compressed Air Systems |
| Waste Heat Recovery | 13 Fans and Pumps |
| 1 Process Insulation | 14 Compressors and Turbines |
| 2 Lighting | 15 Measuring, Metering and Monitoring |
| 3 Electrical | 16 Automatic Controls |
| 4 Energy Efficient Electric Motors | 17 Materials Handling and On-Site Transportation Equipment |
| 5 Combustion | 18 Architectural Considerations |
| 6 Boiler Plant Systems | 19 Thermal Storage. |
| 7 Process Furnaces, Dryers and Kilns | |
| 8 Steam and Condensate Systems | |



© Minister of Supply and Services Canada 1987

Available in Canada through

Associated Bookstores
and other booksellers

or by mail from

Canadian Government Publishing Centre
Supply and Services Canada
Ottawa, Canada K1A 0S9

Catalogue No. M91-6/6E

Canada: \$5.00

ISBN 0-662-14158-X

Other Countries: \$6.00

Price subject to change without notice

All rights reserved. No part of this publication may be reproduced, stored in a retrieval system, or transmitted by any means, electronic, mechanical, photocopying, recording or otherwise, without the prior written permission of the Publishing Services, Canadian Government Publishing Centre, Ottawa, K1A 0S9.

TABLE OF CONTENTS

	Page
INTRODUCTION	1
FUNDAMENTALS	3
Basic Boiler Operation	3
Mass Balances	3
Steam and Water Mass Balance	4
Combustion Process Mass Balance	4
Combustion Process	4
Natural Gas Combustion	5
Oil Combustion	5
Combustion Air	6
Energy Balance	8
Boiler Energy Input	9
Useful Energy	9
Energy Losses	11
Boiler Efficiency Testing	14
Direct Method	14
Indirect Losses Method	15
Soot Blowing	17
Boiler Water Quality	17
Feedwater Temperature	18
Combustion Air Temperature	18
Heat Recovery Boilers	18
Energy Audits	18
Walk Through Audit	19
Diagnostic Audit	19
Boiler Performance Factors Summary	19
EQUIPMENT/SYSTEMS	21
Boilers	21
Firetube Boilers	21
Watertube Boilers	22
Coiltube Boilers	23
Electric Boilers	23

Fuel Types, Characteristics and Conditioning	23
Fuel Burning Equipment	24
Oil Burners	24
Natural Gas Burners	25
Low Excess Air Burners	25
Pulverized Coal Burners	25
Stokers	25
Combustion Air Systems	26
Auxiliary Drives	27
Soot Blowing	27
Environmental Equipment	27
Ash Handling Equipment	27
Air Pollution Control Equipment	27
Heat Recovery	27
Air Preheaters	27
Economizers	28
Flue Gas Condensers	29
Blowdown Heat Recovery	30
Feedwater and Condensate Handling	30
Softeners	30
Dealkalizers	30
Demineralization	31
Deaerators	31
Condensate Tanks	31
Flash Tanks	31
Chemical Injection Equipment	31
Automation Systems	31
Safety Systems	32
Combustion Control Systems	32
Feedwater Control Systems	34
Monitoring Systems	34
Cogeneration Systems	35
ENERGY MANAGEMENT OPPORTUNITIES	37
Housekeeping Opportunities	37
Operation	37
Maintenance	37
Operation Examples	37
Maintenance Examples	38
Low Cost Opportunities	39

Low Cost Examples	39
1. Install Performance Monitoring Equipment	39
2. Relocate Combustion Air Intake	40
3. Recover Blowdown Heat	40
4. Add Insulation	41
5. Reduce Boiler Excess Air	41
Retrofit Opportunities	41
Retrofit Examples	41
1. Install Economizer	41
2. Install Airheater	42
3. Install New Boiler	42
4. Upgrade Burner	43
5. Install Electric Coil Boiler	43
6. Install Turbulator in Firetube Boiler	44
7. Install Flue Gas Condenser	44
8. Convert From Oil to Gas	44

APPENDICES

- A Glossary**
- B Tables**
- C Common Conversions**
- D Worksheet**



INTRODUCTION



Boiler plants are energy intensive operations which are common to many Industrial, Commercial, and Institutional facilities.

A practical approach has been taken to identify most boiler plant energy loss areas and to explain in detail those that are more typical of a boiler plant. Thus, this module will either demonstrate how to calculate the potential energy savings of alternatives or as a minimum, point out energy wasting factors which may be appropriately covered by other modules in this series. This module concentrates on natural gas and oil fired boilers although most of the material would also be applicable to boilers fired by other fuels.

The theme throughout this module has been to concentrate on practical energy saving opportunities. The reading and understanding of this module will provide a good appreciation of boiler plant operation with ideas for improved energy management and dollar savings.

This module describes boiler plant operating principles, equipment, and energy saving opportunities. A brief summary of the module sections follow.

- *Fundamentals* of boiler plant operation describes the combustion process, energy distribution forms, and calculations of energy losses.
- *Equipment/Systems* describes the types of boiler plant equipment.
- *Energy Management Opportunities* provide examples of the options normally associated with boiler plant facilities.
- *Appendices* contain a glossary, tables, common conversions, and a worksheet to assist in calculating boiler efficiency.



FUNDAMENTALS



Boilers are used extensively in Industrial, Commercial and Institutional facilities to generate steam or hot water. Boiler plant operation is energy intensive, making efficient operation an important cost reduction activity. The objective of this module is to describe boiler plant operation and highlight the potential for energy and dollar savings.

Basic Boiler Operation

The basic components of a boiler can be shown schematically (Figure 1). The *fuel* is any substance that can be burned to give off heat and the *air* is required for the combustion of the fuel. *Combustion is the combining of fuel and air in a burning process to produce heat energy.* The furnace is an enclosed space within the boiler where the combustion of fuel occurs. The resulting hot combustion gas contacts heat transfer surfaces prior to leaving the boiler and discharging to the atmosphere through a chimney (stack). The gas leaving the boiler is called *flue gas*. The heat transferred from the combustion flame and hot gas heats the *feedwater* and converts it to *steam or hot water*. The steam or hot water are carriers of heat used according to the facility's requirements. *Blowdown* is not a useful form of energy, but it is necessary to achieve long term satisfactory boiler performance.

The boiler components and functions will be described in more detail. A good understanding of the energy conversion process is essential for optimizing an existing operation or for selecting the best energy source.

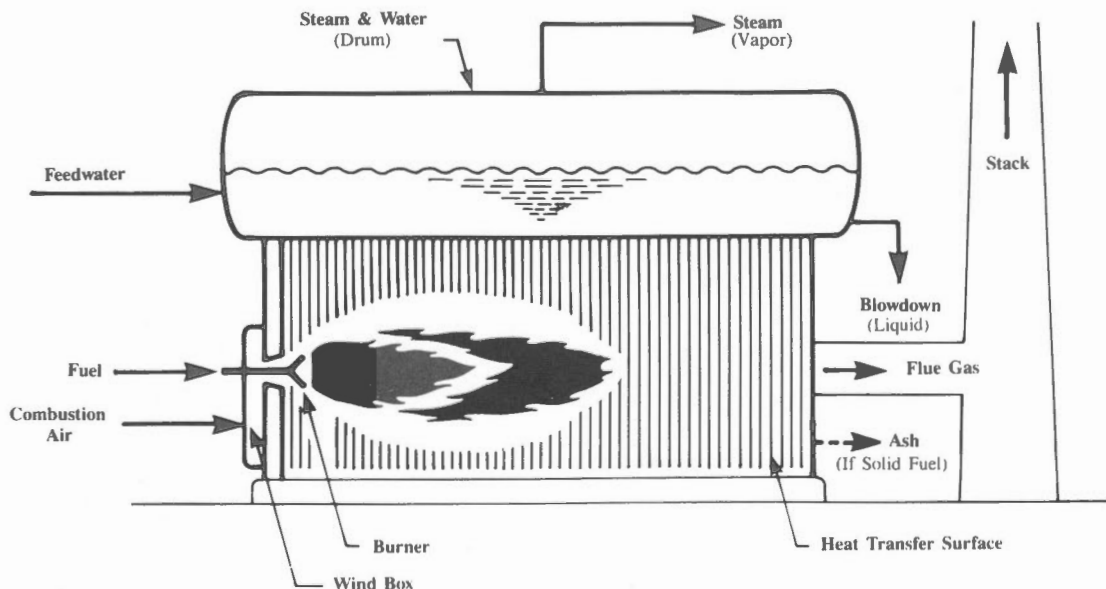

Basic Boiler Operation
Figure 1

Mass Balances

A boiler must transfer heat to the feedwater to form steam while meeting other operational requirements such as steam capacity, pressure and temperature. The boiler functions are subdivided in the following text to demonstrate the mass balances that can be performed.

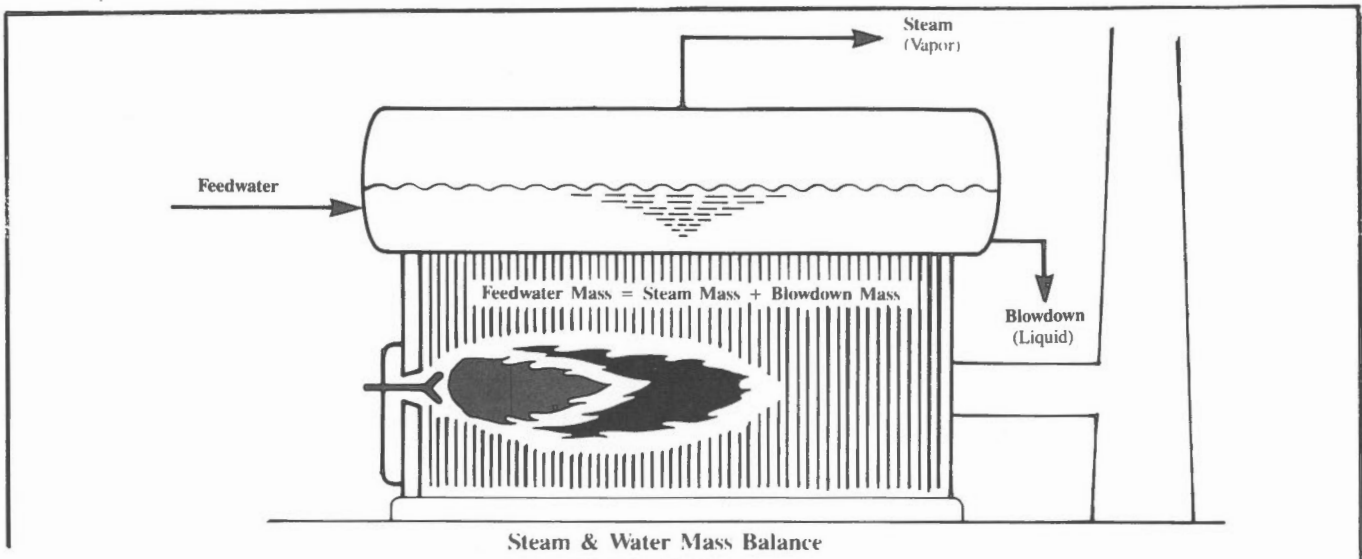

Figure 2

Steam and Water Mass Balance

The mass balance for the water and steam circuit within a boiler is described in Figure 2. In this context mass refers to weight of the components. The feedwater represents 100 per cent of the input while the output is represented by up to 10 per cent blowdown of boiler water with usable steam being the remainder.

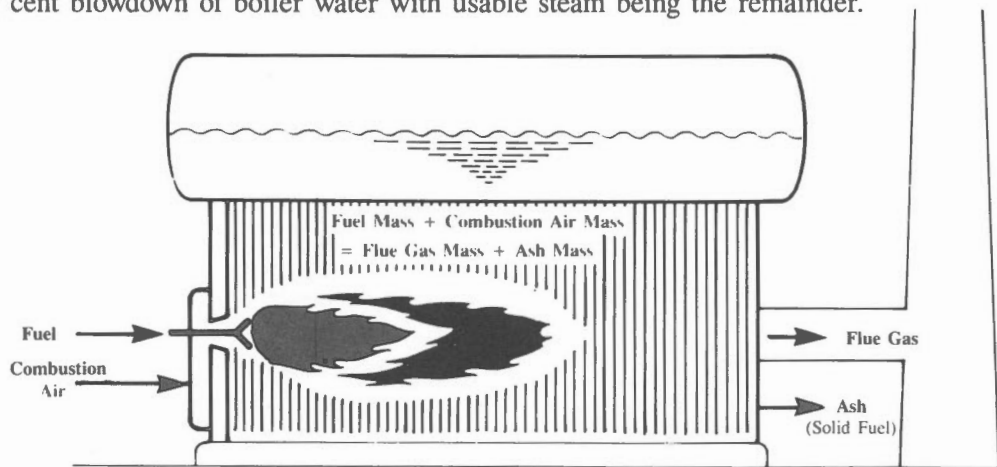

Figure 3

Combustion Process Mass Balance

In the combustion process the fuel and combustion air represent the mass input. The combustion air mass is substantial because it is approximately 15 times the mass of fuel. For gas and oil firing the flue gas represents the equivalent mass leaving the boiler (Figure 3). In the case of solid fuels such as coal and wood, ash would be a part of the output mass in the balance equation.

Combustion Process

Combustion is the rapid chemical combination of carbon and hydrogen in the fuel with oxygen from the combustion air. Fuel burns as a gas even though it may be fed to the boiler as a liquid or solid. A successful combustion process requires time, temperature and turbulence which are sometimes referred to as the '3 Ts'. Turbulence refers to the intimate mixing of the fuel and air at the discharge of the burner in the case of gas and oil fired boilers. Temperature relates to the temperature within the combustion chamber (furnace) while time refers to the period of time required for the combustion process to be completed within the furnace. Good mixing of fuel and air plus turbulence in the burning zone accelerates the combustion process. This results in a higher furnace temperature and less time required to complete the combustion process.

Natural gas and various grades of oil are the most common fuels today. These fuels and the required combustion air will now be described in greater detail.

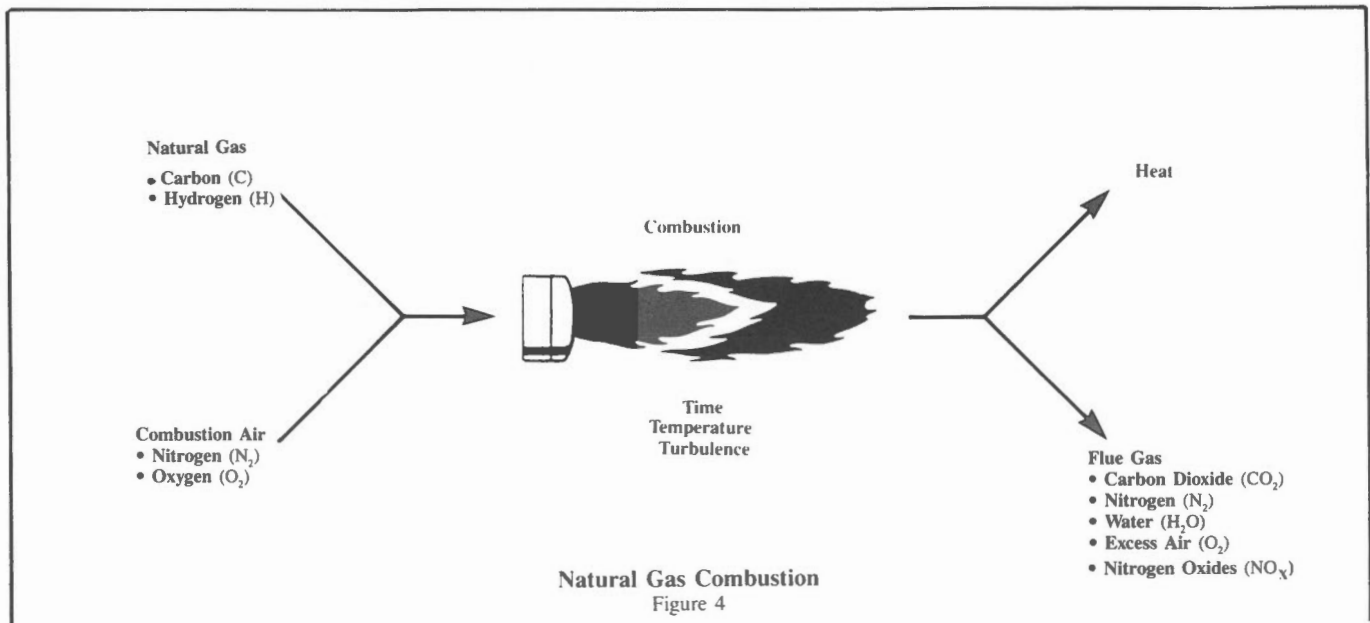

Natural Gas Combustion

Natural gas is an easy to use clean burning fuel. It does not require on-site storage and mixes easily. The prime constituents are methane (CH_4) and ethane (C_2H_6). The higher heating value (HHV) of natural gas is 37.2 MJ/m^3 . The natural gas combustion process is shown in Figure 4. The flow of natural gas is normally specified in terms of m^3/h at the standard conditions of 101.325 kPa (absolute) and 20°C .

Oil Combustion

Oil is more difficult to transfer and burn than natural gas. Oil must be stored on-site, and pumped to the boiler. The heavier and more viscous No. 6 oil must be heated in a storage tank and then again immediately before burning. Heating of this heavier oil is required for pumping and good atomization to achieve proper mixing with the combustion air. Normally up to 2 per cent of boiler steam output is used to assist in the atomizing action for No. 6 oil.

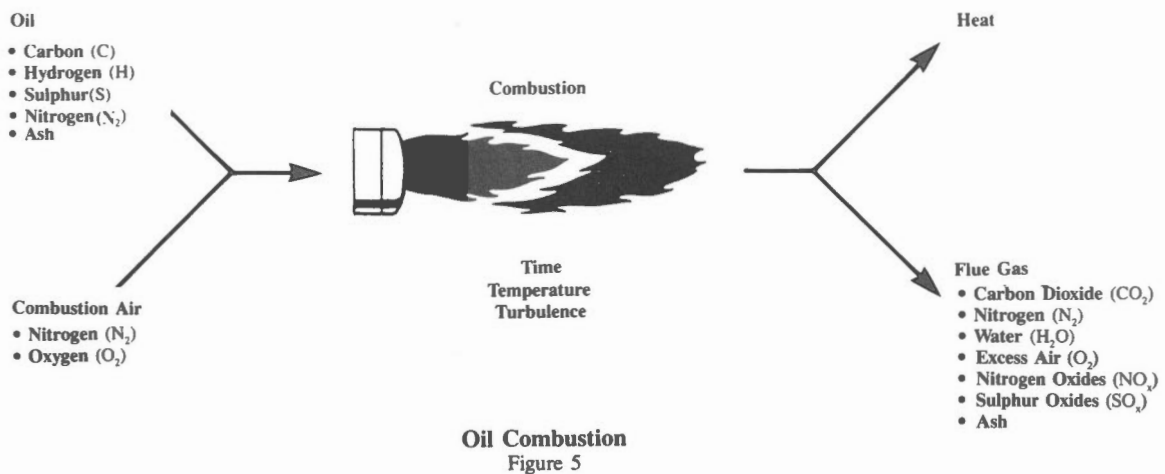

Oil is comprised of more chemical elements than natural gas and this results in more gas types and ash in the flue gas. (Figure 5). The combustion process converts some of the carbon in the fuel to soot which collects on the boiler tubes, decreasing the transfer of heat to the boiler water. If the flue gas temperature decreases below dew point, which is the temperature at which condensation begins, sulphurous and sulphuric acid will condense out of the flue gas. This acid then attacks the surfaces exposed to the low temperature flue gas including air heaters, economizers, breeching, and the stack.

Combustion Air

Stoichiometric air is the theoretical amount of combustion air required to burn a fuel completely. The stoichiometric air calculation assumes that there is perfect mixing and burning of fuel and air, however, this is never achieved. This air quantity can be calculated from the fuel analysis or determined from Table 1. The values quoted do not change significantly with variations in fuel analysis. The higher heating value (HHV) of the fuel should be obtained from the fuel supplier, however the values given in Appendix C are sufficiently accurate for most purposes.

The recommended minimum amount of excess air for the burner and fuel should be obtained from the boiler or burner manufacturer. If this information is unavailable, the Table 1 typical mass values can be used as a guide. Analysis of the flue gases, and observation of the combustion conditions and stack outlet are necessary to arrive at the best achievable result. As an example, the total combustion air requirements for a boiler using 1500 m³/h of natural gas with a burner designed for 10 per cent excess air can be calculated.

From Table 1, the combustion air required at 0 per cent excess air (stoichiometric) is 318 kg/GJ. From Appendix C, the HHV natural gas is 37.2 MJ/m³.

$$\begin{aligned}\text{Total heat input} &= \text{Fuel consumption} \times \text{Fuel HHV} \\ &= 1500 \text{ m}^3/\text{h} \times 37.2 \text{ MJ/m}^3 \\ &= 55\,800 \text{ MJ/h} \\ &= 55\,800 \frac{\text{MJ}}{\text{h}} \times \frac{1}{1000} \frac{\text{GJ}}{\text{MJ}} = 55.8 \text{ GJ/h}\end{aligned}$$

$$\begin{aligned}\text{Combustion air mass (0\% excess air)} &= \text{Theoretical air required per unit of heat} \times \text{heat input} \\ &= 318 \text{ kg/GJ} \times 55.8 \text{ GJ/h} \\ &= 17\,744 \text{ kg/h}\end{aligned}$$

$$\begin{aligned}\text{Combustion air mass (10\% excess air)} &= 17\,744 \text{ kg/h} \times 1.1 \\ &= 19\,518 \text{ kg/h}\end{aligned}$$

The density of air at standard conditions [20°C and 101.325 kPa (absolute)] is 1.204 kg/m³.

$$\begin{aligned}\text{Total combustion air} &= \frac{19\,518 \text{ kg/h}}{1.204 \text{ kg/m}^3} \\ &= 16\,211 \text{ m}^3/\text{h} \text{ at standard conditions}\end{aligned}$$

The foregoing procedures can be repeated for an oil example in which a boiler burns 7000 L/h of No. 6 oil, at 15 per cent excess air. From Table 1, combustion air at 0 per cent excess is 327 kg/GJ. The HHV of No. 6 oil with 2.5 per cent sulphur is 42.3 MJ/L (Appendix C).

$$\begin{aligned}\text{Total combustion air mass} &= \frac{7000 \text{ L/h} \times 42.3 \text{ MJ/L} \times 327 \text{ kg/GJ} \times 1.15}{1000 \text{ MJ/GJ}} \\ &= 111\,348 \text{ kg/h}\end{aligned}$$

$$\begin{aligned}\text{Total combustion air volume} &= \frac{111\,348 \text{ kg/h}}{1.204 \text{ kg/m}^3} \\ &= 92\,482 \text{ m}^3/\text{h} \text{ at standard conditions}\end{aligned}$$

The appearance of the burner flame can be a guide to correct combustion conditions. Commissioning fuel firing equipment requires experience. It is wise for the operator to check the appearance of the flame immediately after an experienced burner service representative has performed this task. A natural gas flame should be clear or slightly blue. An oil flame should be a light brown or yellow. A short blowtorch shaped flame indicates too much air, whereas a long, lazy, smoky flame indicates too little air.

The actual excess air values should be regularly compared with the recommended values. The most accurate method of determining the actual percentage of excess air is by analyzing the flue gas leaving the boiler. This is often achieved with a continuous O₂ or CO₂ analyzer which indirectly identifies the excess air or a CO analyzer which measures the presence of combustibles.

The Orsat is an instrument for analyzing a flue gas sample for the percentage by volume of oxygen (O₂), carbon dioxide (CO₂), and carbon monoxide (CO). The remaining gas is nitrogen (N₂). The sample should be taken as close to the boiler exit as possible to reduce errors caused by the infiltration of air. There are simpler manual analyzers available that measure CO₂ or O₂ in the flue gas. These are easier to use and can be useful as a cross check against the primary analyzer provided that CO is not present. If CO is detected, it is an indication that there is inadequate air to complete the combustion process. For natural gas, oil or coal firing, the percentage excess air can be obtained from Figure 6 provided that CO is not present. For other fuels, or when CO is in the flue gas, the following equation should be used.

$$\% \text{ Excess Air} = \frac{\text{O}_2 - 0.5 \text{ CO}}{(0.2682 \text{ N}_2 - (\text{O}_2 - 0.5 \text{ CO}))} \times 100$$

Where, O₂ = oxygen by volume (%)

CO = carbon monoxide by volume (%)

N₂ = nitrogen by volume (%)

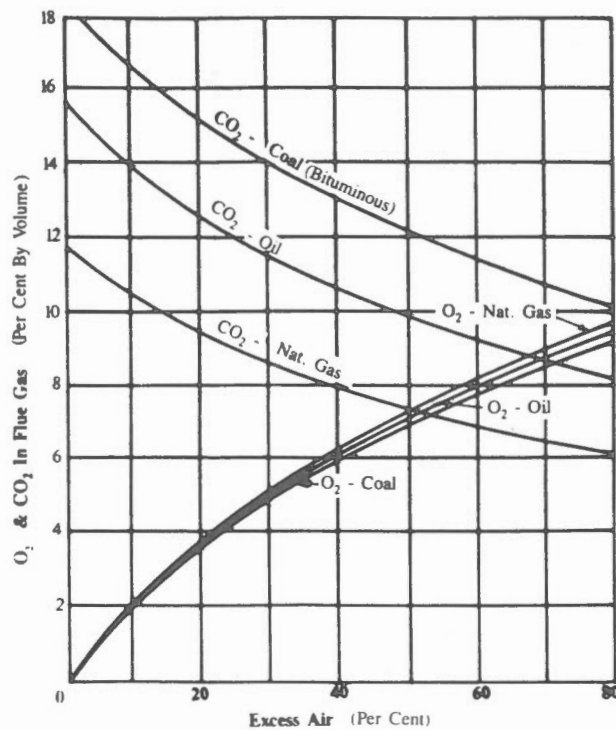

Per Cent O₂ And CO₂ Versus Excess Air

Figure 6

This equation can also be used as a check against the Figure 6 values for natural gas or oil firing. For example, the flue gas analysis by volume for burning natural gas in a boiler gives the following result.

$$\text{O}_2 = 5.4\%$$

$$\text{CO}_2 = 8.8\%$$

$$\text{CO} = 0\%$$

$$\text{N}_2 = 85.8\% \text{ (by difference)}$$

Figure 6 shows that the excess air is about 30 per cent. These flue gas readings can be used in the previous equation to calculate the excess air for comparison purposes.

$$\begin{aligned} \% \text{ Excess air} &= \frac{5.4 - (0.5 \times 0)}{(0.2682 \times 85.8) - [5.4 - (0.5 \times 0)]} \times 100 \\ &= 30.7\% \end{aligned}$$

Another example is a boiler burning bituminous coal. The flue gas analysis is shown below.

$$\text{O}_2 = 4.1\%$$

$$\text{CO}_2 = 14.8\%$$

$$\text{CO} = 0\%$$

$$\text{N}_2 = 81.1\% \text{ (by difference)}$$

With the use of Figure 6 and the O_2 reading, the excess air equals approximately 24 per cent. Using the CO_2 reading with the same figure results in a value of about 23 per cent excess air. Obviously, there cannot be two excess air values for a common gas sample and the difference could be attributed to two possibilities.

- The analysis of coal from different parts of North America varies so that the CO_2 curve in particular might not quite match the coal in the example.
- There could be an error in the O_2 or CO_2 reading.

The excess air can be calculated as a check against the use of Figure 6.

$$\begin{aligned} \% \text{ Excess air} &= \frac{4.1 - (0.5 \times 0)}{(0.2682 \times 81.1) - [4.1 - (0.5 \times 0)]} \times 100 \\ &= 23.2\% \end{aligned}$$

The two Figure 6 curve readings of 24 and 23 per cent as well as the calculated value of 23.2 per cent are sufficiently close together for purposes of routinely checking the combustion process for efficient operation. It is desirable to reduce the combustion air relative to the fuel flow to determine whether the excess air can be reduced further. Would combustibles occur in the form of CO or would some undesirable conditions occur within the furnace? If not, the excess air can be reduced to save boiler fuel. Some margin in the excess air is required to protect against undesirable changes in the adjustments of instruments and other equipment.

Energy Balance

An energy balance, as shown in Figure 7, is a method of accounting for the useful energy and losses of a boiler. The energy balance can be generalized in equation form.

$$\text{Boiler energy input} = \text{Usable energy} + \text{Energy losses}$$

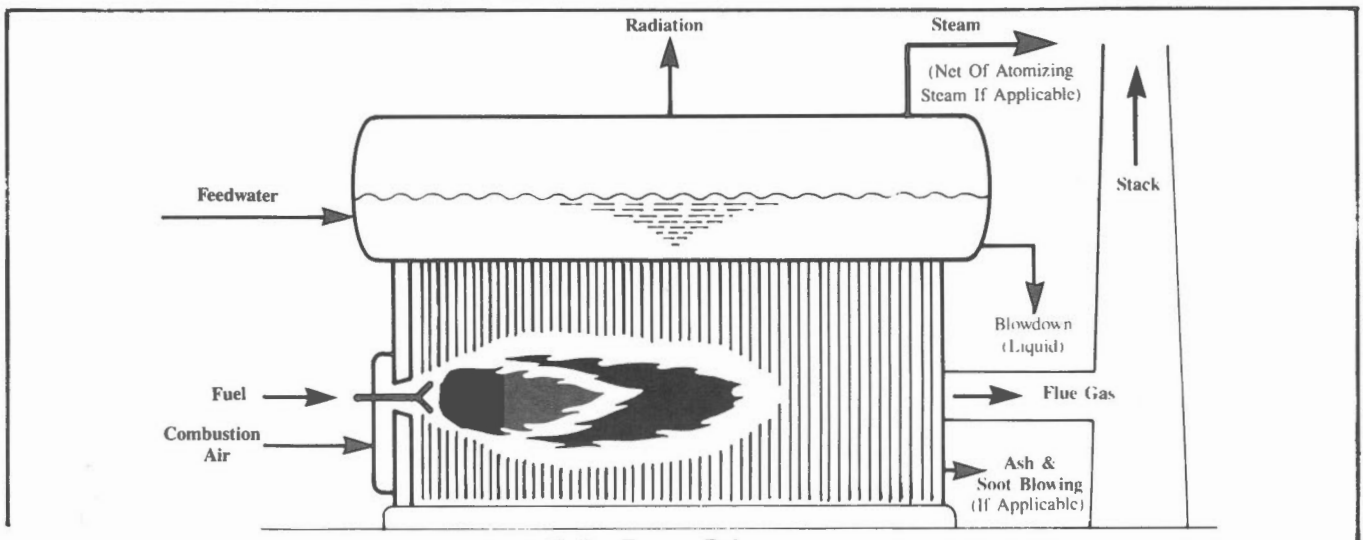

Boiler Energy Balance
Figure 7

Boiler Energy Input

The three sources of boiler heat energy input are the fuel, feedwater and combustion air.

The major energy source is from the fuel which can be expressed in terms of MJ/m³ for gas and MJ/L for oil. In the case of No. 6 oil, it is necessary to heat the oil in the storage tank sufficiently to permit pumping and then heat it further prior to going to the burner. The thermal energy of the oil as it is delivered to the boiler should be added to the *higher heating value* of the oil to represent the total fuel energy input. Representative fuel higher heating values are provided in Appendix C.

The feedwater temperature must also be considered as part of the energy input (i.e. higher temperature feedwater requires less heat energy from the fuel to be converted to steam). The feedwater temperature can be used to determine this heat energy input level. The energy content of the feedwater is the enthalpy (h_f) as determined in steam tables corresponding to the feedwater temperature (Table 2).

Combustion air is normally drawn from within the boiler plant, but it may be ducted from outside and heated with steam. A higher combustion air temperature will reduce the energy input required from the fuel.

Useful Energy

The boiler converts fuel energy into a form that is suitable to convey heat energy throughout a facility. The most common forms of energy distributed from boilers are steam, hot water and thermal fluids.

Steam is the most common means of conveying heat throughout a facility. As heat is added to water, the temperature of the water increases until the boiling point is reached (Figure 8). This heat, which increases the water temperature, is called *sensible heat*. When the boiling point is reached, the further addition of heat causes some of the water to change to steam, but the mixture of steam and water remains at the boiling temperature. At atmospheric pressure the boiling point of water occurs at 100°C. The heat which converts the water to steam at the constant boiling temperature is called *latent heat*. When the steam has been fully vaporized at the boiling temperature it is called dry saturated steam. This means that there are no droplets of moisture within the steam.

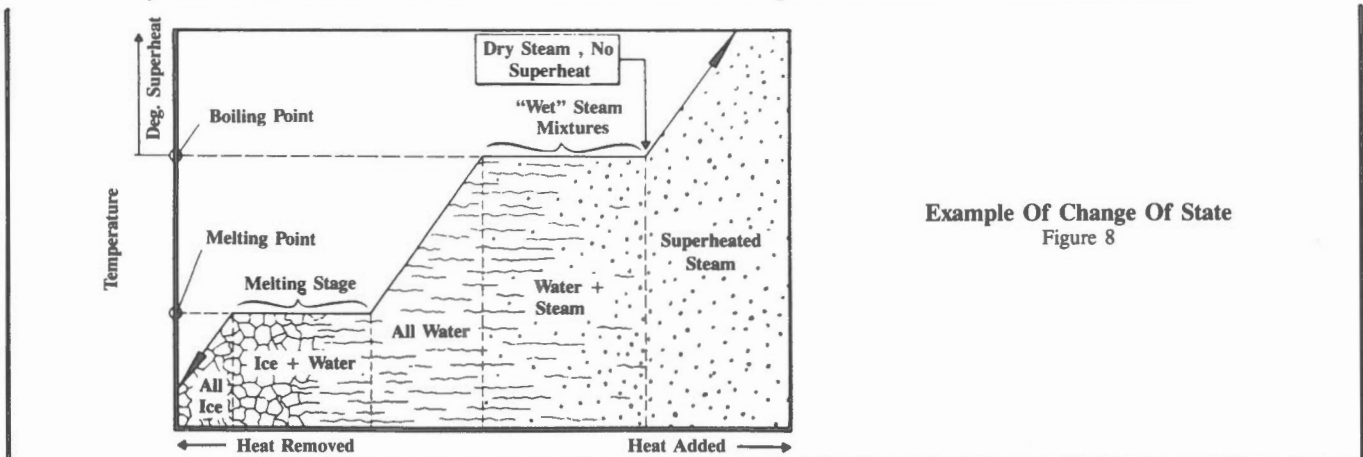

Example Of Change Of State
Figure 8

When water is heated at a pressure above atmospheric, the boiling point will be higher than 100°C and the sensible heat required will be greater. For every pressure there is a corresponding boiling temperature, and at this temperature the water contains a fixed, known amount of heat. The greater the pressure, the higher the boiling temperature and heat content.

The unit of heat energy used in the SI system is the joule. Steam tables (Table 2) are used to establish the energy content of water and steam. The use of steam tables is helpful in analyzing the operating effectiveness of a boiler plant. *Enthalpy* is the expression used to identify the energy content of water, steam and water mixture, or steam.

Under the enthalpy heading there are three columns; enthalpy of the liquid (h_f), enthalpy of evaporation (h_{fg}), and enthalpy of steam (h_g).

The *enthalpy of liquid* (h_f) is a measure of the amount of heat energy contained in the water at a specific temperature.

The *enthalpy of evaporation* (h_{fg}) (correctly called the latent heat of vaporization) is the quantity of heat energy required to convert one kilogram of water to one kilogram of steam at the given pressure.

The *enthalpy of steam* (h_g) is the total heat energy contained in dry saturated steam at a given pressure. This quantity of energy is the sum of the enthalpy of the liquid (h_f) and the amount of energy required to evaporate one kilogram of water at the saturation temperature (h_{fg}).

The three previous figures for enthalpy may be expressed in an equation.

$$h_g = h_f + h_{fg}$$

Where, h_g = Enthalpy of dry saturated steam (kJ/kg)

h_f = Enthalpy of liquid (kJ/kg)

h_{fg} = Enthalpy of evaporation (kJ/kg)

Most boilers are designed to produce dry saturated steam. Steam tables can be used to compare the energy content of dry saturated steam at the two pressures of 200 and 1000 kPa(absolute).

Note that the steam tables give properties based on absolute values of pressure. Pressure gauges normally indicate values above atmospheric pressure, which, at sea level, is 101.325 kPa. Absolute values of pressure are given by the following equation.

$$\text{Absolute pressure} = \text{Gauge pressure} + 101.325 \text{ kPa}$$

- 200 kPa(absolute) Dry Saturated Steam

Sensible heat (h_f)	504.7 kJ/kg
Latent heat of evaporation (h_{fg})	<u>2201.6</u>
Total heat (h_g)	2706.3 kJ/kg

- 1000 kPa(absolute) Dry Saturated Steam

Sensible heat (h_f)	762.6 kJ/kg
Latent heat of evaporation (h_{fg})	<u>2013.6</u>
Total heat (h_g)	2776.2 kJ/kg

From the foregoing enthalpy comparison it should be noted that, as the steam pressure increases, the amount of sensible and total heat increases and the latent heat decreases.

The enthalpy cannot be directly obtained from steam tables when there is moisture in the steam. The steam *quality* can be expressed in equation form.

$$\text{Steam quality} = \frac{\text{Mass of steam vapor}}{\text{Mass of steam vapor and water mixture}}$$

It should be noted that steam quality of 0.98 means that there is 2 per cent moisture in the steam. The heat content of 1000 kPa and 0.98 quality steam can be calculated using steam table data.

$$\text{Sensible heat (} h_f \text{)} \qquad 762.6 \text{ kJ/kg}$$

$$\begin{aligned} \text{Latent heat} &= h_{fg} \times \text{steam quality} \\ &= 2013.6 \times 0.98 \qquad \underline{1973.3} \end{aligned}$$

$$\text{Total heat} \qquad 2735.9 \text{ kJ/kg}$$

The difference between this condition and the previously calculated dry saturated steam enthalpy represents the heat required to eliminate the 2 per cent moisture.

$$\begin{aligned} \text{Heat required to eliminate moisture} &= 2776.2 - 2735.9 \\ &= 40.3 \text{ kJ/kg} \end{aligned}$$

Superheated steam is produced when saturated steam is heated to a temperature higher than the saturation temperature. The enthalpy value (heat content) can be read directly from superheated steam tables (Table 2) at the point corresponding to the steam temperature and pressure. The amount of superheat in steam is expressed in degrees of superheat (the number of degrees Celsius to which the steam is heated above the saturation temperature).

Hot water can also be used as the medium to transport heat. The temperature conditions vary according to the heating system design, but are generally classed as follows:

- High-temperature hot water (HTHW) – Greater than 176°C
- Medium-temperature hot water (MTHW) – 121°C to 176°C
- Low-temperature hot water (LTHW) – Less than 121°C

A *thermal fluid boiler* is similar to a hot water boiler, but is fired by oil or gas to heat thermal fluid that is pumped to where the heat energy is required. This fluid might be heated to 370°C at pressures below 350 kPa(gauge) while still remaining in the liquid form.

Energy Losses

Energy loss is a crucial topic in terms of efficient boiler plant operation. The losses which follow, can be influenced by design and operating factors.

- Flue gas
- Radiation
- Unburned combustibles
- Unmeasured

The *flue gas heat loss*, which is the heat discharged from the stack, is usually the largest loss in a fuel fired boiler. Flue gas analysis and flue gas temperature can be used to calculate the loss. If there is no heat recovery equipment on the boiler, these measurements should be taken at the boiler outlet to minimize the possibility of the readings being affected by air infiltration. With heat recovery equipment the readings should be taken immediately downstream of the equipment.

The flue gas heat loss has three components which can be calculated separately.

- Dry gas heat loss.
- Heat loss from the water vapor produced by the combustion of the hydrogen in the fuel.
- Heat loss from the water vapor produced by the evaporation of moisture in the fuel.

For natural gas and oil, the moisture in the fuel is minimal, and the evaporation of the moisture heat loss can be ignored. Thus, the total of the first two losses can be obtained with sufficient accuracy from Figure 9 for natural gas and Figure 10 for No. 2 Oil. Calculation of these losses follow in the text.

Consider a previous natural gas example where the excess air percentage was calculated to be 30.7 per cent. The temperature of the flue gas leaving the boiler was 200°C. From Figure 9, the flue gas heat loss to the stack is 18.5 per cent of the fuel input. From Appendix C, the HHV of natural gas is 37.2 MJ/m³.

$$\text{Flue gas heat loss} = 37.2 \times 0.185 = 6.9 \text{ MJ/m}^3 \text{ of fuel burned.}$$

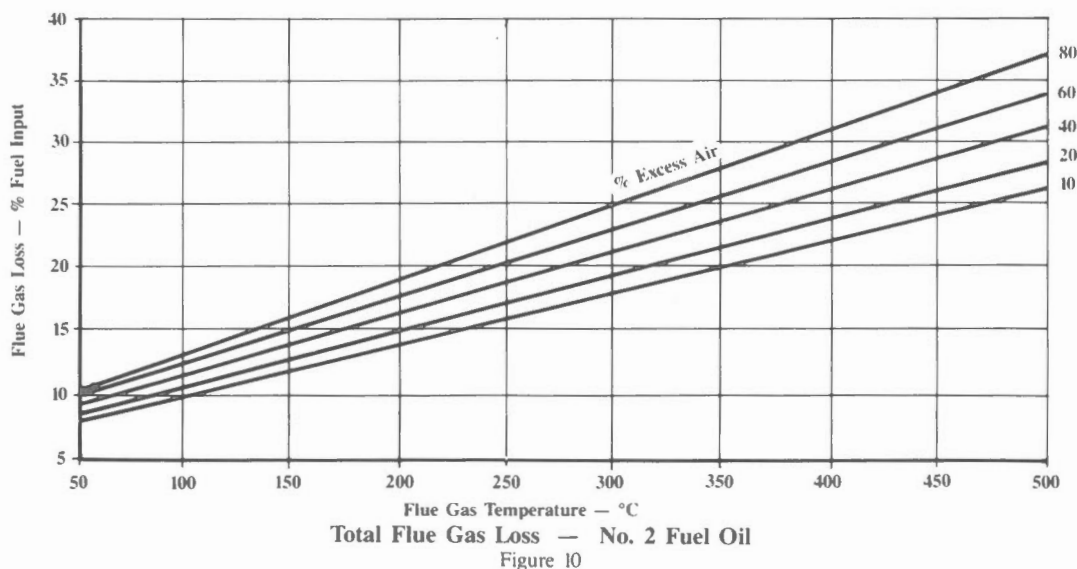
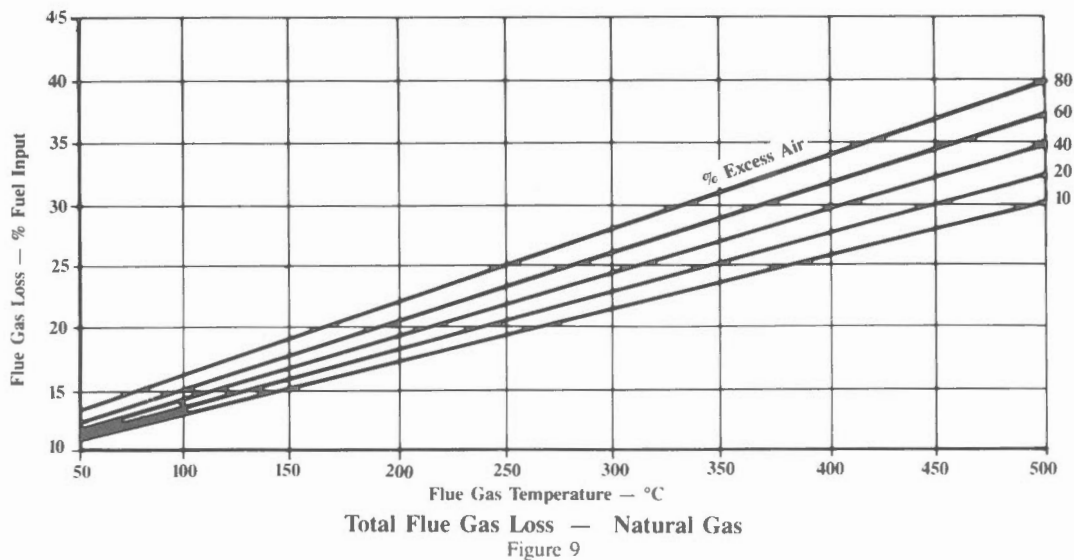

For fuels such as coal, biomass, industrial waste or municipal refuse, the heat loss from the moisture in the fuel can be considerable. Wood, for instance, could have a moisture content of up to 60 per cent, depending on the source and capability of the wood burning equipment. Figure 11 shows the variations in the moisture heat loss for a typical biomass fuel having different moisture contents at a flue gas temperature of 200°C. At 30 per cent moisture, this fuel heat loss is 5.5 per cent of the fuel heat content. At 60 per cent moisture, the loss increases to 21 per cent.

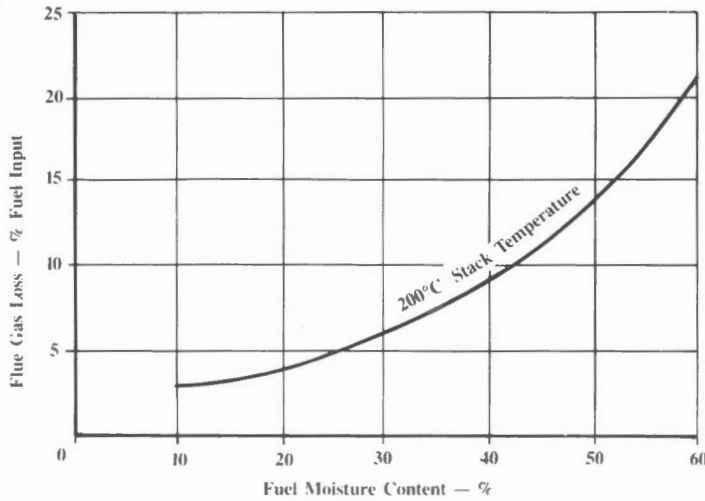

Typical Biomass Fuel — Variation In Flue Gas Loss
With Fuel Moisture Content
Figure 11

The *radiation heat loss* of a boiler is primarily a function of the applied thermal insulation. Insulation reduces the heat radiating from the boiler, and maintains the outside surfaces at a temperature low enough for safety. The quality and thickness of the insulation on the various sections of the boiler are normally determined by the surface temperature. Most safety regulations require that metal surfaces within reach of personnel not exceed 50°C. The heat loss from the casing is difficult to measure accurately. Figure 12 is derived from the American Boilermakers' Association Standard Radiation Chart, and can be used to estimate the heat loss. Radiation loss is independent of the type of fuel fired, and use of this chart requires only a knowledge of the output rating of the boiler and the nature of the furnace walls.

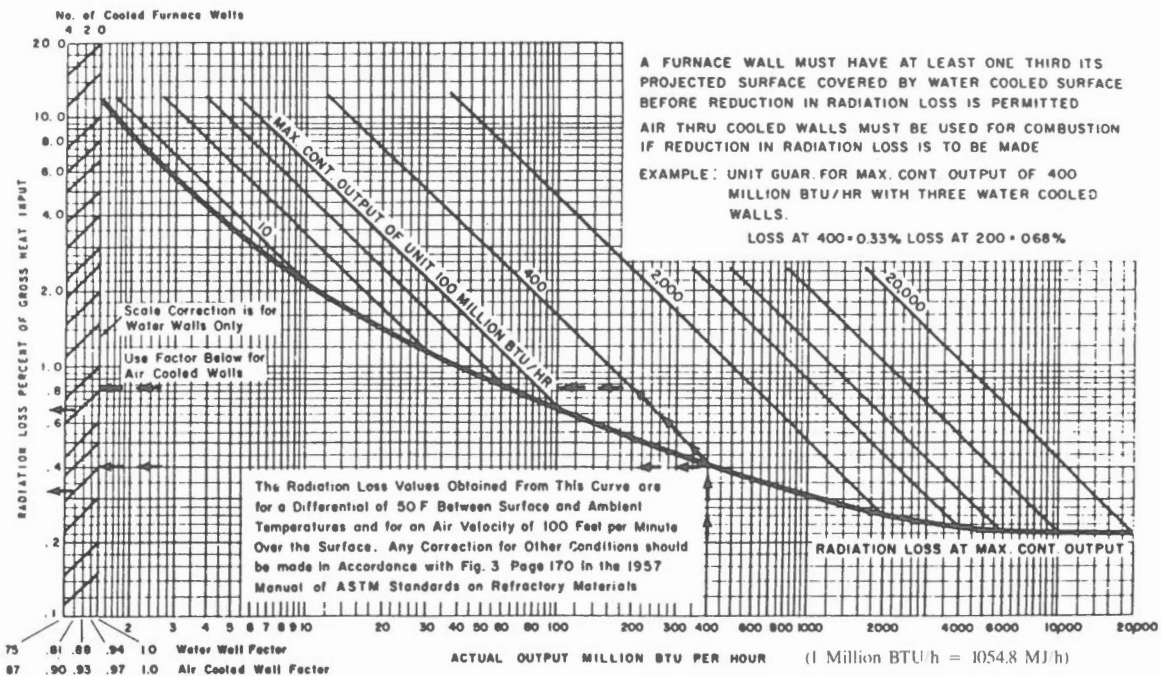

ABMA Standard Boiler Radiation Loss Chart
Figure 12

For example, consider a packaged watertube boiler with a full load rated output equivalent to 50 GJ/h with all four furnace walls water cooled. From the chart, the heat loss due to radiation would be 0.65 per cent of gross heat input. Note that if the boiler was operating at half capacity, the radiation loss would be 1.4 per cent of gross heat input. It can therefore be seen that a penalty will be paid in increased percentage radiation losses if a boiler is operated on part load for an extended period of time. The absolute heat loss to the flue gas would be lower at part load, because the gas volume is lower. However, the overall boiler efficiency would likely be lower.

The *unburned combustibles heat loss* is not significant for properly operating oil and gas fired installations, but it can be for solid fuel boilers. Figure 13 demonstrates that there could be a minor unburned fuel loss at the maximum efficiency point, but the real significance of this figure is that the losses increase very rapidly as the total air is decreased. The measure of this condition is reflected by the presence of significant combustibles in the flue gas.

In coal, biomass and other solid fuels, unburned combustible material will be found in the refuse collected in the ash pit and the fly ash hopper. The loss should be determined when the boiler is tested for efficiency. To do so requires a method of collecting and weighing the refuse under controlled conditions and laboratory testing the refuse for its HHV. The loss can be calculated as shown.

$$\text{Unburned combustible heat loss} = \text{Dry refuse quantity} \times \text{Refuse heat content}$$

Where units are:

Heat loss (MJ/kg fuel as-fired)

Dry refuse (kg of refuse/kg of as-fired fuel)

Refuse heat content (MJ/kg of refuse)

Unmeasured losses include relatively minor losses such as sensible heat in the ash or slag, radiation to the ash pit, moisture in the air and heat pick-up in the cooling water. They are usually not measured because the effort is not justified. Minor losses also include a tolerance for instrument error. The boiler manufacturer will usually recommend an overall allowance, but this should not exceed 0.5 per cent of the heat in the fuel.

Boiler Efficiency Testing

Boiler efficiency can be determined by the direct and indirect methods which follow.

Direct Method

This method measures the efficiency of the boiler as the ratio of the heat produced by the boiler (heat output) to heat content of the fuel (heat input).

$$\text{Boiler efficiency} = \frac{\text{Boiler heat output}}{\text{Boiler fuel heat input}} \times 100$$

This method requires accurate measurement of the quantity and heating value of the fuel, and of the heat produced by the boiler in the form of steam.

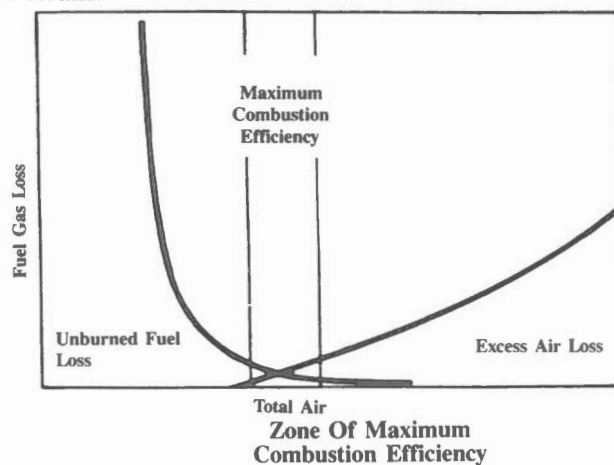

Figure 13

Oil flow can be measured by volumetric instruments of the displacement rotating disc type. For natural gas, orifice flow measurement or displacement type meters can be used. Solid fuels require measurement by gravimetric feeders or weigh scales. All fuels require an accurate determination of the HHV which may involve careful sampling and laboratory tests. Natural gas and oil heating values should be obtainable from the fuel supplier. Solid fuels require careful sampling techniques to ensure that moisture is not lost between the sample being taken and the laboratory test.

The heat output of the boiler requires a measurement of the steam flow at the boiler outlet and this is usually an orifice flow measurement. A pressure measurement is required at the boiler outlet and a temperature measurement must be taken at the boiler feedwater inlet. If the steam generated is superheated it will be necessary to measure the steam temperature. The steam quality should be confirmed for boilers designed to produce dry and saturated or wet steam. The efficiency is expressed by the following equation.

$$\begin{aligned} \text{Boiler efficiency} &= \frac{\text{Heat added to feedwater}}{\text{Boiler fuel heat input}} \times 100 \\ &= \frac{f_s (h_1 - h_2)}{w_f \times \text{HHV} \times 1000} \times 100 \end{aligned}$$

Where, f_s = Steam flow at boiler outlet (kg/h)

h_1 = Enthalpy (total heat) in steam flow at boiler outlet (kJ/kg)

h_2 = Enthalpy of feedwater (kJ/kg)

w_f = Fuel flow (L/h for liquid, kg/h for solid fuel, and m^3/h for gaseous fuels)

HHV = Higher heating value (MJ/L for liquid, MJ/kg for solid fuel, and MJ/m^3 for gaseous fuels)

1000 = Conversion factor, kJ to MJ

Example: A packaged watertube boiler, when tested, was evaporating 10 000 kg/h of water at 105°C, to steam at 1500 kPa(absolute) and 240°C. The No. 2 oil flow rate during the test was 805 L/h. Laboratory tests established an oil HHV of 38.68 MJ/L. The boiler efficiency can be calculated from this data.

From steam tables,

Enthalpy of steam at 1500 kPa(absolute) and 240°C 2899.2 kJ/kg

Enthalpy of water at 105°C 440.17 kJ/kg

$$\begin{aligned} \text{Efficiency} &= \frac{10\,000 \times (2899.2 - 440.17)}{805 \times 38.68 \times 1000} \times 100 \\ &= 79.0\% \end{aligned}$$

Indirect Losses Method

This method measures the efficiency of the boiler as the heat content of the fuel (heat input), minus the heat losses from the boiler, divided by the heat input.

$$\text{Boiler efficiency} = \frac{\text{Boiler heat output}}{\text{Boiler heat input}} \times 100$$

Output = Input - Losses

$$\text{Boiler efficiency} = \frac{\text{Input} - \text{Losses}}{\text{Input}} \times 100$$

Boiler efficiency testing using the direct input-output method is inconvenient and expensive if the boiler is not equipped with fuel and steam flow meters. Even if this metering equipment is available, efficiency measurement by the heat-loss method has the following advantages over the input-output method.

- More informative since it establishes the individual losses for comparison with predicted performance.
- More accurate, since the total losses are normally in the region of 15 to 25 per cent of the fuel heat input, hence errors in measurement have less effect on the end results.
- The basic loss measurements are simple, being only fuel analysis and heating value, exit gas temperature, boiler exit flue gas analysis, combustion air temperature and refuse combustible content.

Boiler heat losses are evaluated in accordance with the following categories.

- Dry gas heat loss.
- Moisture in fuel heat loss.
- Heat loss owing to water vapor from combustion of hydrogen in the fuel.
- Radiation heat loss
- Combustible in refuse heat loss.
- Unmeasured losses.

These losses have already been explained in this module. Procedures for the calculation of boiler efficiency for different fuels are given in the ASME Performance Test Code for Steam Generating Units, PTC 4.1. Worksheet 6-1 can be used to calculate heat losses and boiler efficiency for boilers burning natural gas or oil. This worksheet can be used for the input-output and the indirect methods of efficiency calculation.

Consider the previous example used to illustrate the input-output method. The packaged watertube boiler, with 4 water-cooled combustion chamber walls had a rated capacity of 10 000 kg/h of steam at 1500 kPa(absolute) and 240°C.

Steam pressure at boiler outlet 1500 kPa(absolute)

Steam temperature at boiler outlet 240°C

Water temperature at boiler inlet 105°C

Air temperature around boiler 20°C

Flue gas temperature leaving boiler 260°C

Fuel temperature 20°C

Water evaporation rate 10 000 kg/h

Rate of fuel fired 805 L/h

Oil HHV 38.68 MJ/L

Flue gas analysis at boiler outlet (% by volume)

CO₂ = 12.8

O₂ = 3.8

CO = 0

N₂ = 83.4 (by difference)

Worksheet calculations:

Excess air (Figure 6)	20%
Dry gas + H ₂ O loss (Figure 10)	17.2%
Radiation loss (Figure 12)	1.2%
Unmeasured loss,	0.5% (estimated)
Total losses	= 17.2 + 1.2 + 0.5 = 18.9%
Boiler efficiency	= 100 - 18.9
	= 81.1%

The data and results of this example, together with those of the previous input-output example, as shown on Worksheet 6-1 (p 46).

When a new boiler is installed, the efficiency should be checked throughout the firing range against the purchase guarantees. The boiler efficiency should then be regularly checked using the acceptance test values as the basis of comparison. Figure 13 clearly demonstrates that the total air should not be decreased or increased beyond the zone of maximum combustion efficiency.

Soot Blowing

Soot blowing systems are required on all boilers burning solid fuels or oil. Natural gas is a clean-burning fuel and does not require soot blowers. Soot blowing is the on-line fireside cleaning of the heat transfer surfaces. This prevents sections of the boiler from becoming plugged with ash and other solid products of combustion. Plugged sections can restrict flue gas flow causing load limitations and tube erosion. Most importantly, soot blowing assists energy management by maintaining the maximum rate of heat transfer from the fuel to the water and steam.

Inadequate soot blowing can result in the boiler exit gas temperature rising by as much as 80°C. Every 20°C rise in exit gas temperature will increase the stack heat loss by an additional 1 per cent of the fuel fired. For example, from Figure 10, it can be seen that a boiler firing No. 2 oil with 10 per cent excess air will give up an additional 4.2 per cent of the fuel input if the gas temperature rises by 100°C.

Boiler Water Quality

In using water for the generation of steam, consideration must be given to water treatment to prevent corrosion and scaling of the boiler surfaces in contact with the water. This includes the treatment of the raw water introduced into the boiler cycle, and the conditioning of the water in the boiler.

The boiler manufacturer usually dictates what the feedwater quality and boiler water analysis should be, and the operator must ensure that appropriate treatment is maintained. Failure to do so may result in the formation of scale, which eventually leads to failure of the boiler tubes. Scale inhibits the transfer of heat raising the boiler exit gas temperature and increasing flue gas heat loss. As noted, a moderate rise of 20°C in the flue gas temperature will result in 1 per cent more of the heat in the fuel being wasted.

Boiler water conditioning usually includes phosphate dosing to convert residual hardness salts into a sludge that is removed by blowdown. If left unchecked, the buildup would ultimately cause the boiler water to foam, resulting in undesirable solids being carried over with the steam. Blowdown is the term used to describe the purposeful discharge of a portion of the boiler water to eliminate undesirable sludge and chemical concentrations. Blowdown may be continuous or periodic. The operator usually adjusts the blowdown manually, although equipment is available that automatically adjusts the blowdown rate from a conductivity measurement of the boiler water. In low pressure boilers, where the allowable level of solids in the boiler water may be higher, the required blowdown will be 5 to 10 per cent of the feedwater flow. The required level of blowdown must be strictly maintained, but care must also be taken to ensure that the recommended level is not exceeded.

The blowdown is sometimes piped to an atmospherically vented vessel and the resulting discharge is dumped to waste. If the blowdown is 5 per cent or more, consideration should be given to recovering the flash steam from the vessel by diverting it to the deaerator, or by using the heat for space heating or domestic water.

Feedwater Temperature

Cold water is not normally fed directly to a boiler. The boiler feed pump inlet is usually connected to a condensate return tank, or a deaerator which is used to remove O₂ and CO₂ from the feedwater. The feedwater fed to most low pressure boilers (less than 1000 kPa) is usually between 80 and 120°C.

To keep the size of the boiler heating surfaces within practical limits, the boiler designer selects a flue gas exit temperature about 60 to 90°C above the temperature of the coldest heating surface in the boiler. If the feedwater is introduced directly into the boiler drum it mixes immediately with the already heated boiler water. The result is that the coldest heating surfaces will be only a few degrees lower than the saturation temperature corresponding to the boiler pressure. For example, a boiler operating at 1500 kPa(absolute) with a saturation temperature 198.29°C, will have a flue gas exit temperature of approximately 260°C.

The boiler efficiency can be increased by using flue gas to heat the feedwater. The transfer of heat from the flue gas to the feedwater is accomplished in a heat exchanger called an economizer.

The metal temperature of the coldest section of the economizer will be only a few degrees higher than the feedwater entering the economizer. The exit gas temperature can now be lowered to around 170°C, resulting in a boiler efficiency increase of 3 to 4%.

Including an economizer in a new boiler design, or retrofitting an existing boiler with an economizer, is an effective means of saving energy.

Combustion Air Temperature

A substantial improvement can also be made by preheating the combustion air. This can be achieved by installing an air heater which uses the heat in the flue gas to heat the incoming air. Referring to the previous example, an air heater could be installed instead of an economizer. The combustion air could be preheated by about 120°C, and the exit gas temperature would drop the same amount as in the economizer example, resulting in a 3 to 4 per cent increase in boiler efficiency.

The choice of flue gas heat recovery equipment (air heater or economizer), depends on a number of factors. It is usually feasible to recover the same amount of heat from the flue gas with either type of equipment. The water temperature entering the economizer is generally higher than the air temperature entering the air heater, which would suggest that more heat would be recovered using an air heater. However, the rate of heat transfer from gas to air as in an air heater, is lower than the rate of heat transfer from gas to water, as in an economizer. This tends to favor the economizer. The final choice should be based on a detailed engineering analysis of the boiler and heat recovery system, to consider physical installation arrangements and the best financial payback.

Heat Recovery Boilers

Heat recovery boilers recover sensible heat from flue gas produced by equipment external to the boiler. Such boilers are effectively a continuation of the exhaust duct from equipment such as a gas turbine, incinerator or furnace.

The efficiency of a waste heat boiler does not have the same meaning as the efficiency of a fuel fired boiler. This is because the heat input is in the form of flue gas heat instead of heat produced by burning fuel. The losses to the boiler stack are calculated in the same way as for a fuel fired boiler, but consist of dry gas losses only since there is no fuel burned to produce water vapor. Effective heat recovery depends almost entirely on reducing the temperature of the gas leaving the boiler to the lowest economical level.

Radiation losses from the boiler can be determined from Figure 12 but some allowances must be made for the the ductwork heat loss between the flue gas source and boiler.

The operator must minimize wasted energy by properly using soot blowing, water treatment and blowdown procedures. Good maintenance practices ensure minimum heat wastage through steam and water leaks, and deteriorating insulation and casing.

Energy Audits

An energy audit involves the identification of the amount of energy consumed by a boiler and the associated auxiliaries. The audit may be applied to the entire boiler plant, or it may be concentrated on one or two pieces of equipment, depending on how much is known about existing energy usage. Reference should be made to the manual, "Conducting An Energy Audit" in this series for further information.

Walk Through Audit

The initial action is a walk through audit which is a tour through the plant looking for obvious signs of energy waste. It is often helpful to engage someone for this task who is not normally associated with the plant operation. A fresh viewpoint will often detect items that have been overlooked.

Diagnostic Audit

An overall appreciation of energy usage is achieved in a diagnostic audit by reviewing plant records to determine energy usage per unit of boiler output over the last several years.

The original equipment specifications and any initial commissioning test reports are an excellent way to determine if the individual items of equipment are performing as they should, or if there has been significant performance deterioration. Confirmation of the plant's present performance should be made by conducting tests at several loads. The boiler efficiency, and the associated boiler heat losses can be determined by the previously described methods.

All boiler plants should at least have a fuel input recorder, a steam or feedwater flow recorder, a boiler outlet pressure indication, and temperature measurements of the incoming feedwater and the flue gas leaving the boiler.

After obtaining an overview of past and present patterns of energy consumption, comparisons can be made with the original equipment specifications and performance. Significant performance deterioration should indicate which equipment or system requires further detailed investigation.

The audit may also suggest where the original design of the equipment could be improved or replaced. Major retrofits consisting of heat recovery equipment should be evaluated.

The determination of the energy consumed per unit of boiler output (kg/h of steam) will often show significant variations. If the fuel consumption per unit of output rises significantly as the process demand on the boiler falls, it may be possible to improve the situation with better steam production scheduling so that the boiler is operated at maximum efficiency.

Boiler Performance Factors Summary

Large amounts of energy are used in boiler plants and there are many factors which can affect the energy utilization efficiency. This section briefly summarizes the key performance factors to help focus attention on the potentially high energy savings available. In some cases there will be boiler or auxiliary equipment design limitations, but it is still important to be fully aware of the efficiency improvement possibilities.

Flue gas temperature is a key measurement to highlight the largest energy loss source in boiler operation. It is important to regularly monitor this temperature at different firing rates so that departures from normal are detected quickly. Some of the factors which could affect the flue gas temperature are listed.

- Increased excess air causes the flue gas temperature to rise.
- Gas short circuiting between the furnace and boiler exit will decrease the heat transfer area and increase flue gas temperature.
- Infiltration air into the furnace lowers the temperature of the flue gas, increases the volume and velocity of the gas, all of which decrease the heat transfer.
- Heat recovery equipment increases the heat transfer area which increases the transfer of otherwise wasted heat to lower the temperature of the flue gas at the heat exchanger exit.
- Heat transfer surfaces, which are fouled on the outside with soot or on the inside with scale, decrease heat transfer and increase the flue gas temperature.
- Higher boiler operating pressure results in a higher temperature on the inside of the boiler tubes. Higher boiler water temperature decreases the heat transfer rate which increases the flue gas temperature and losses.

Figures 9 and 10 illustrate the impact of the flue gas temperature on the flue gas heat loss.

The minimum attainable excess air is a function of the design capabilities of the boiler and burner at different firing rates and the combustion control system. *Excess air* influences boiler efficiency as illustrated by the following examples.

- Insufficient excess air causes combustibles to be present in the flue gas which results in rapid increases in the fuel energy losses.
- Too much excess air increases the mass flow of the flue gas which increases the flue gas losses. Flue gas temperature increases 1 per cent for each additional 4 per cent excess air.

Fouled heat transfer surfaces caused by the build-up of soot on the outside or of scale on the inside of the boiler tubes retards heat transfer from flue gas to boiler water.

- With oil or solid fuel firing the tubes should be cleaned regularly by means of sootblowers. The buildup of soot over a few days of operation can increase the flue gas loss by 50 per cent.
- Scale build-up on the inside of water tubes retards heat transfer and can overheat the metal to cause a rupture. A 1 mm scale build-up may increase the fuel consumption by 2 per cent.

Improper feedwater treatment can cause scale build-up as just described or require additional blowdown to avoid scale build-up. For a 1600 kPa(absolute) boiler with feedwater at 105°C, an increase in blowdown from 4 to 8 per cent results in a 0.5 per cent additional heat loss.

Radiation loss (in MJ's absolute) from a boiler is approximately constant for all firing rates. Thus, the percentage loss from radiation increases as the boiler load decreases. Other factors interact, but the net result is that the efficiency capability of a boiler is affected by load. Each boiler should be tested to establish the variation of efficiency with load.

Combustion air temperature affects the energy input to the boiler. The use of an air preheater, which uses the flue gas to heat the combustion air, increases the heat input while at the same time decreasing the flue gas temperature and heat loss.

Boiler efficiency will be influenced by the fuel primarily because of the latent heat loss from moisture in the fuel. Using natural gas as the base, the ranking of common fuels is as follows:

- Coal with approximately 6 per cent higher efficiency than natural gas.
- Oil with approximately 4 per cent higher efficiency than natural gas.
- Wood with 50 per cent moisture at 12 per cent lower efficiency than natural gas.

It must be realized that the criteria for selecting one fuel over another is the overall operating cost comparison and not the efficiency in isolation. Depending on the fuel costs, the lowest efficiency wood fuel could represent the best economic choice.

To summarize, there are important principles for efficiently operating a boiler plant as listed below.

- Know the optimum values of the described important measurements.
- Understand the energy loss impact of the measurements departing from the optimum values.
- Regularly monitor all important boiler variables.
- Take action to eliminate undesirable variances as soon as they occur.

EQUIPMENT SYSTEMS



Boilers

The four principal boiler types are the firetube, watertube, coiltube and electric.

Firetube Boilers

These are essentially shell and tube heat exchangers where the combustion gas passes through tubes immersed in water (Figure 14).

Firetube boilers usually burn natural gas or oil, although some, with a firebox type of combustion chamber, can be installed on top of a coal or wood burning stoker. They can generate dry saturated steam or hot water up to a maximum pressure of 1700 kPa(gauge). The output ranges from 350 to 28 000 MJ/h. The boilers are shop assembled and delivered with integral burner, forced draft fan, and controls.

Since firetube boilers operate at low pressures, the boiler water temperature is correspondingly low, ranging from 110°C to 200°C. By ensuring that the combustion gas contacts as much of the heat transfer surface as possible, the flue gas temperature can be reduced to within 50°C of the boiler water temperature. This minimizes the flue gas heat loss and can result in boiler efficiencies in excess of 80 per cent.

Firetube boilers respond relatively slowly to changes in demand for steam. The controls can be arranged for the steam pressure to be maintained during periods of low or no demand by the intermittent firing of the burner. This type of boiler is commonly used in smaller boiler plants.

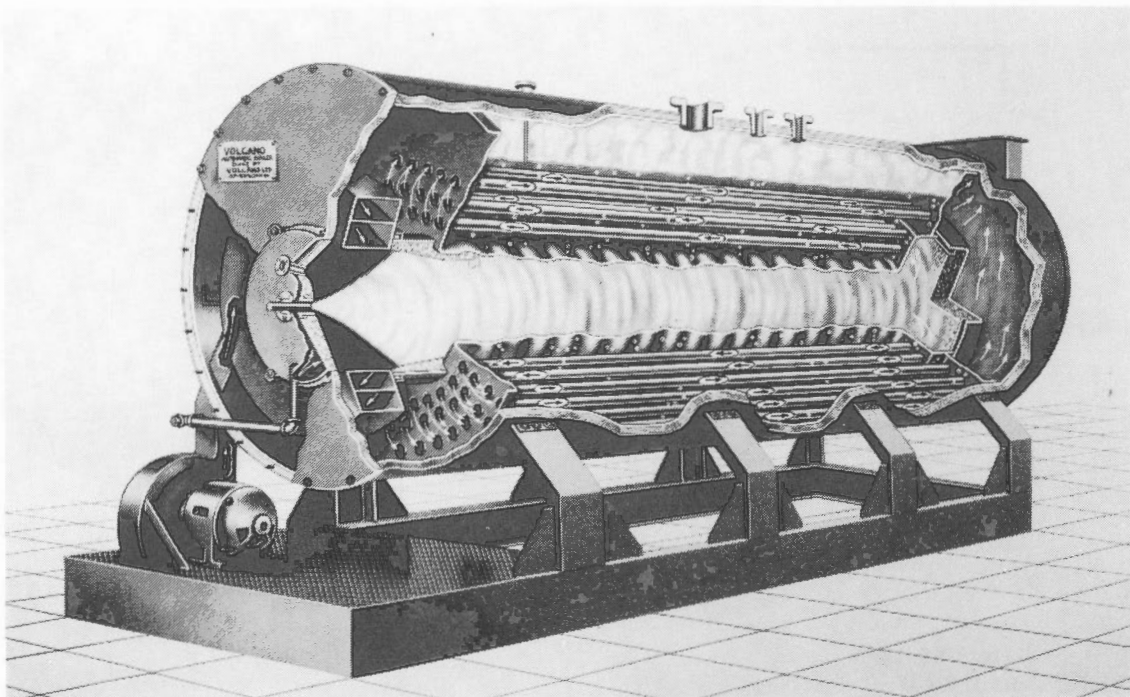

Firetube Boiler
Figure 14

Courtesy of Volcano Limited

Watertube Boilers

The watertube boiler is capable of firing any type of combustible material in a wide range of capacities. Watertube boilers operate at pressures up to 30 000 kPa(absolute) and can produce steam at up to 565°C.

The water to be heated is carried inside banks of steel tubes, with the hot gas on the outside of the tubes. The most common boilers consist of a drum connected by vertical tubes (downcomers) to a lower drum or header(s). The downcomers can be heated or unheated. A further set of tubes (risers) connect the two drums and form the walls of the combustion chamber (Figure 15). Natural circulation begins when the heat supplied to the risers exceeds that supplied to the downcomers, thereby producing a mix of steam and water in the risers of less density than that of the water in the downcomers.

Natural gas or oil fired units are usually delivered as factory-assembled "packaged" boilers (Figure 16). Packaged boilers range in size from about 1500 to 190 000 MJ/h, which covers the normal size range of most boilers. For solid fuels, the boilers are site erected, as the large size of the combustion chamber and fuel-firing equipment does not make shipment possible.

Steam heating systems have inherent efficiency losses in phase changes between water and steam, trap and vent losses, and the flashing of steam from condensate. Hot water and thermal fluid systems experience heat losses, but they do not approach those described for steam. Thus, fluid boilers utilize energy more effectively and may also be sized for a lower MJ/h capacity than a steam boiler.

Hot water boilers are similar in appearance and operation to steam units. The circulation of water through the tubes is achieved by pumping.

All watertube boilers are capable of operating continuously at any load, from about 15 to 100 per cent of the rated capacity. The highest thermal efficiency normally occurs at about 85 per cent of rated capacity, with efficiencies falling more significantly at loads lower than 60 per cent. The small internal water capacity permits quick response to sudden steam demand changes, and frequent start-up and shutdown operation.

The best energy utilization of a watertube boiler results from steady demand at 85 per cent of rated capacity with the avoidance of sudden swings in demand or frequent shutdowns.

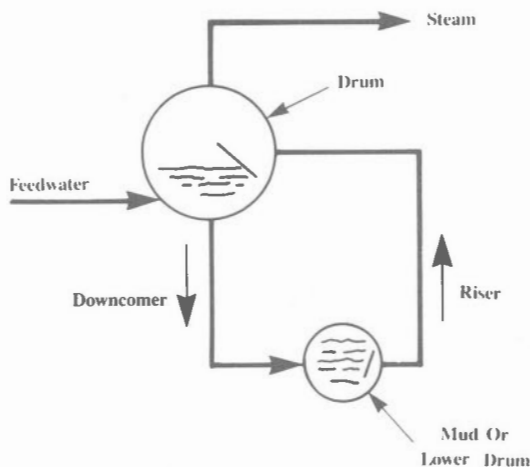

Boiler Circulation
Figure 15

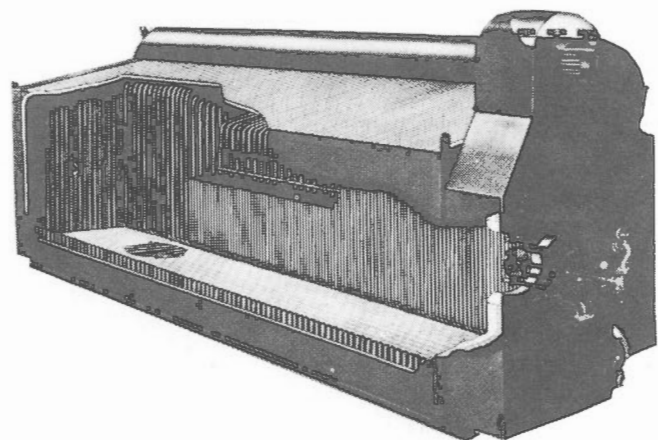

Watertube Boiler
Figure 16

Courtesy of Babcock & Wilcox Canada

Coiltube Boilers

Coiltube boilers are essentially forced circulation watertube boilers (Figure 17). The convection bank can be constructed from a single coiled tube or parallel connected tubes. The water is forced through the coils by means of a positive displacement pump. These units are shop assembled complete with insulation, combustion air blower, burner, feed pump, separator and controls.

Coiltube boilers burn natural gas or oil, or a combination of both fuels. They generate hot water or saturated steam at pressures ranging from 450 to 2400 kPa(absolute). They are available in many capacities up to a maximum of 17 500 MJ per hour.

The normal water content of coiltube boilers is very low compared to other boiler types. Consequently, they can be started up and shutdown in a comparatively short time (10 minutes). They respond rapidly to large load swings, and can maintain low fire for long periods of time. Under no-load conditions, they can cycle between “On” and “Off” to maintain system pressure and temperature. The full-load thermal efficiency compares with watertube boilers (+80 per cent), and low load efficiencies are 1 to 2 per cent higher with coiltube boilers.

Coiltube boilers are ideal for small steam and hot water systems that are started and shutdown on a shift or daily basis or where there is a combination of sudden, large load demands and long periods of low or no demand.

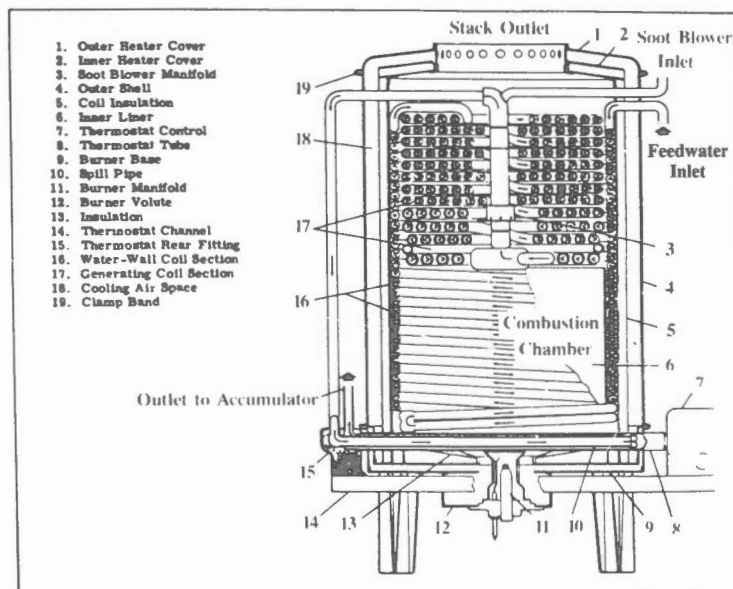

Coiltube Boiler

Figure 17

Courtesy of Clayton Industries

Electric Boilers

Hot water or steam can be generated in boilers where the water is heated electrically with immersion coils. Electric boilers are more efficient than fuel fired boilers because there are no flue gas losses to the stack. Electrical energy is often not competitive with other fuels, but this should be checked particularly with respect to interruptible or “off-hour” rates.

New 3-pass firetube boilers, with ratings of 1600 to 16 000 MJ/h, are available with electric heaters as well as gas or oil burners. These boilers are considerably more expensive, but they provide the flexibility of frequent changes which could be the use of gas during the day and electricity at night.

Fuel Types, Characteristics and Conditioning

The most common types of fuels used in boiler plants are listed below:

- No. 2 Oil
- No. 6 Oil
- Natural gas
- Coal
- Biomass (wood & wood waste)
- Municipal waste

No. 6 oil is viscous at ambient temperature which means that it has a high resistance to flow. Consequently, No. 6 oil requires heating so that it can be pumped through the oil piping system and be suitable for atomization by the burner. The heating starts at the storage tank where coil heaters, in the bottom of the tank, or suction heaters, connected to the outlet flanges, raise the temperature of the oil to about 65°C. The oil pressure is then raised to between 700 and 1700 kPa(absolute) and further heated to a temperature of 90 to 120°C, depending upon the type of burner and grade of oil. This is done with pumps and heaters placed close to the boiler. Oil pipelines require heat-tracing to prevent the oil from becoming too viscous when the system is not in use. The heat for this equipment can be supplied by steam or electricity, but plant steam is preferred because of lower cost. Because of these handling difficulties, No. 6 oil is not normally used as a standby to another fuel. Until recent years, the price of No. 2 oil was much higher than that for No. 6 oil, which made the use of No. 6 an economic proposition, despite the additional equipment required. The current low price differential may create an energy management opportunity of replacing No. 6 oil with No. 2 oil, and eliminating the need for heating the standby fuel.

Pulverized coal facilities require significant energy for drying, grinding, classification and transport purposes.

Wood residue from primary and secondary wood industries can be burned as a substitute for natural gas and oil. Wood firing requires more operator involvement than more common fuels but, depending on the cost of the wood residue and the ability of the wood burning facility to operate throughout the year, the conversion could be financially attractive. Wood firing has been successfully achieved in institutional environments where dirt and noise cannot be tolerated. Some size reduction and metal recovery may be required on-site depending on the wood fuel source.

Municipal waste represents a source of energy that can be used to generate steam and hot water. The public attitude toward transporting this material to user sites and storing it, plus the high cost of building a facility to prepare the material for burning, short term storage, moving and burning it and then cleaning the flue gases before discharging them to the atmosphere has limited the use of this abundantly available energy source.

Fuel Burning Equipment

Burner designs vary according to the type of fuel and the application objectives, but they must all do the following.

- Direct the fuel to the combustion chamber
- Direct the air to the combustion chamber
- Effectively mix the fuel and air
- Once the burner has been ignited it must continue to ignite the incoming fuel

Oil Burners

Oil must be atomized and simultaneously mixed with air to sustain combustion. An oil burner consists of a central tube with an atomizing device at the end, and a register that surrounds the barrel and serves to distribute the flow of air to the furnace (Figure 18).

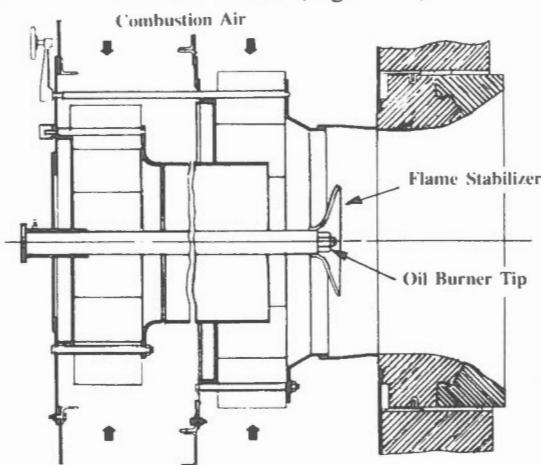

Oil Burner
Figure 18

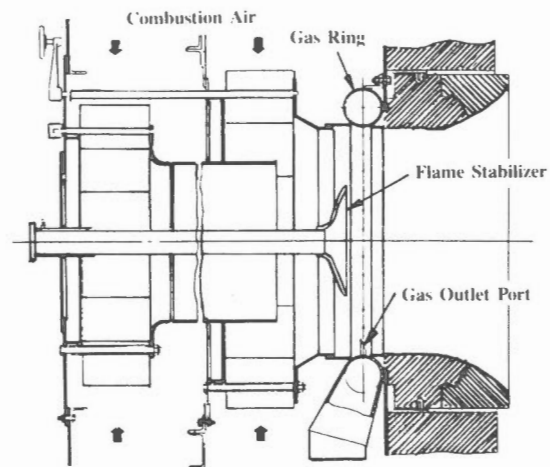

Gas Burner
Figure 19

Courtesy of Peabody Engineering Canada

Mechanical oil burners can be used to atomize No. 2 or 6 oil, but the pressure must be very high to obtain acceptable turndown. The burner turndown ratio is the ratio of the maximum to minimum fuel flows which produce satisfactory combustion. An example of the pressure difference for 5:1 turndown would be that a mechanical oil burner would require 4500 kPa oil pressure whereas a steam atomized burner would only require 650 kPa pressure for the same turndown.

Most No. 6 oil burners use steam-assisted atomizers where steam is mixed with the oil in the atomizing tip to break up the oil particles. This type of burner requires less oil pressure than the straight mechanical type, and has a better turndown ratio of up to 5:1.

Burners firing No. 2 oil often use air-assisted atomizers to attain turndown ratios of up to 5:1. Steam-assist burners may also be used for this lighter oil.

Natural Gas Burners

Natural gas mixes readily with air. The ring-type gas burner consists of a circular barrel ringed with multiple outlet ports (Figure 19). The "spud" type burner consists of a ring of 4 to 8 single barrels, each with a widened end containing multiple outlet ports. In either case the register surrounds the barrels with air.

Many boilers are equipped with combination natural gas and oil burners with the second fuel used as back up for the prime fuel.

Low Excess Air Burners

Standard natural gas and oil burners operate at 10 to 15 per cent excess air at full capacity and higher excess values at lower firing rates. The increasing excess air with decreasing firing rate phenomenon results from burner registers which are fixed at settings that provide best results at full capacity. Low excess air burners permit operation at 2 to 5 per cent excess air. A reduction of excess air from 15 to 5 per cent would reduce fuel costs by almost 1 per cent. These savings result from higher cost features as follows:

- Better design of the air diffusers, air register, and burner which achieve better mixing and combustion.
- Burner registers which are modulated with the firing rate to provide better combustion at firing rates below 100 per cent.

Pulverized Coal Burners

The barrel of a pulverized coal burner (Figure 20) consists of a large diameter steel tube fitted with internal distribution vanes. The coal and hot primary air, which were previously mixed in the pulverizer, are introduced tangentially to the barrel, to impart a strong rotation in the barrel. Adjustable inlet vanes also impart a rotation to the preheated secondary air entering the register. The degree of air and fuel swirl, coupled with the shape of the burner throat, establishes a recirculation pattern extending into the combustion chamber. Once the coal is ignited, the combustion heat in the furnace stabilizes the flame.

Stokers

Stokers are mechanical devices that burn solid fuel in a bed at the bottom of a combustion chamber. They are designed to permit continuous or intermittent fuel feed, fuel ignition, adequate supply of combustion air, release of gaseous products, and disposal of ash.

Stokers are classified according to the manner in which the fuel reaches the fuel bed. In an underfed stoker, the fuel and air enter the burning zone from beneath the bed. Overfed stokers have the fuel entering the combustion zone from above, in the opposite direction to the air flow. The spreader-type overfed stoker delivers fuel so that a portion burns in suspension while the remainder falls and burns on the moving grate.

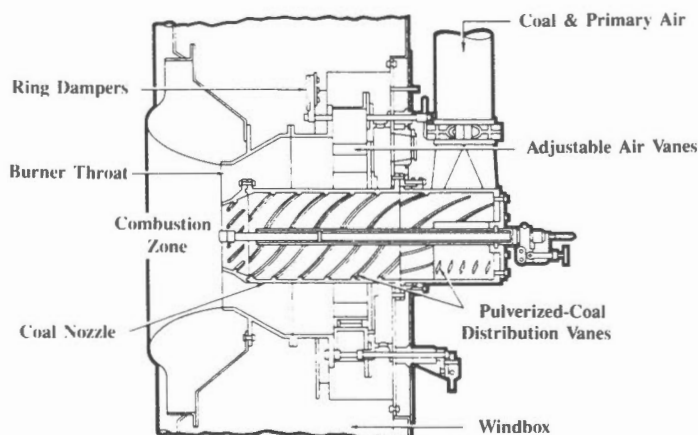

Pulverized Coal Burner
Figure 20

Courtesy of Combustion Engineering, Inc.

Combustion Air Systems

Combustion air can be supplied to the boiler by a natural, forced, or balanced draft system (Figure 21).

Natural draft (Figure 21A) uses the negative pressure (draft) produced by the boiler stack to draw air into the boiler, and remove the flue gas. The most common example of this is the domestic gas furnace. It is more difficult to control the fuel-air ratio for efficient combustion with natural draft firing and the leakage of air into the furnace increases the flue gas losses. The draft must be great enough to draw the combustion gas over the heating surfaces. An induced draft fan could overcome the lack of stack created draft, but if a fan had to be added a forced draft fan would normally be preferred. Natural draft is usually applied only to small furnaces with less than 1000 MJ/h of heat input.

The forced draft combustion air system is most commonly used for firing natural gas or fuel oil (Figure 21B). A fan supplies combustion air to the boiler and also forces the combustion gas over the heating surfaces of the boiler to the base of the stack. The draft generated by the stack assists in discharging the gas to atmosphere. Air flow is regulated by varying the fan inlet dampers to control the fuel-air ratio at all firing rates. Better mixing of the air and fuel is possible because of the turbulence caused by the higher air pressure differential across the burner. The percentage of excess air can be lower for forced draft systems with resulting lower heat loss to the flue gas. The disadvantage of the forced draft system is that a relatively high positive pressure within the boiler casings results in some heat losses if the furnace casing is poorly designed, constructed or maintained. This type of system is successfully used for small to very large boilers.

The balanced draft system (Figure 21C) is used when firing fuels such as coal (either pulverized or stoker fired), biomass, or municipal refuse. Solid fuels require a slightly negative pressure in the furnace to prevent leakage of fly ash and gas into the boiler room. The forced draft (F.D.) fan, provides the combustion air while the induced draft (I.D.) fan draws the gas from the combustion chamber over the boiler heating surfaces to the base of the stack. This system also permits close control of the fuel-air ratio at all firing rates. Maintaining the gas pressure within the boiler casing at a slight negative value minimizes the infiltration of air through the casing and the subsequent heat loss.

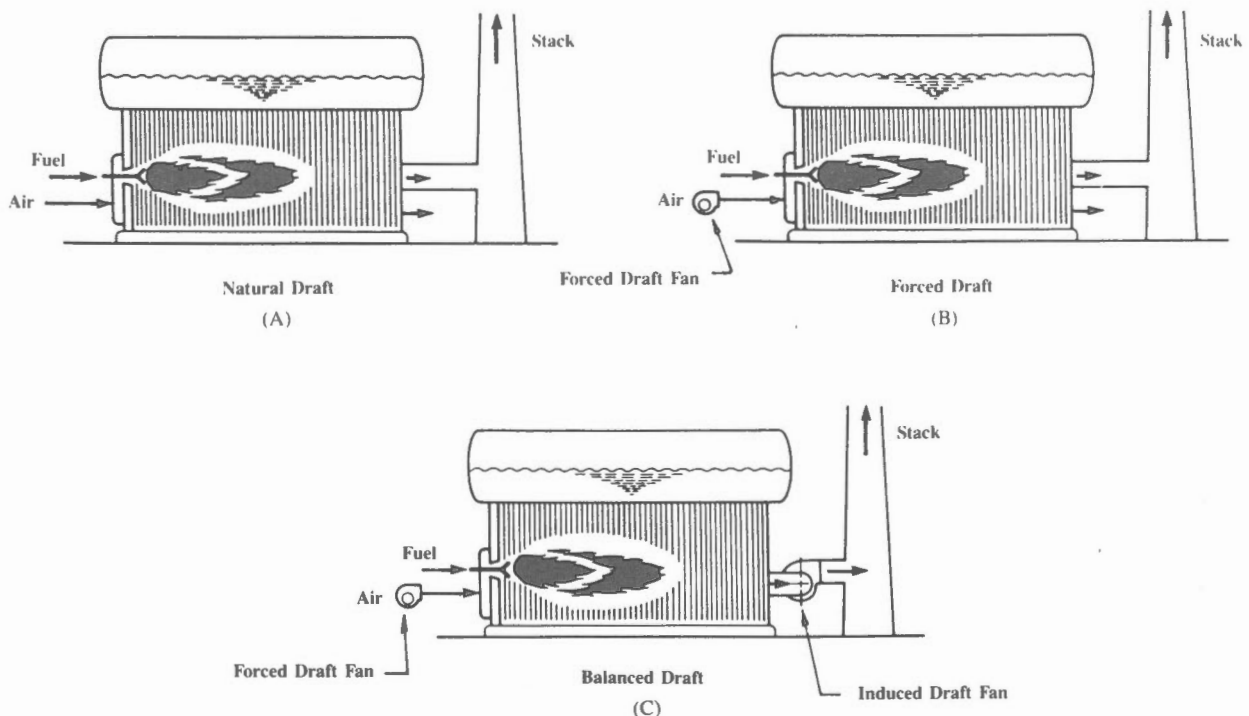

Combustion Air Systems
Figure 21

Auxiliary Drives

The drives of the feed pumps, forced and induced draft fans are usually electric motors. These pumps or fans may be steam turbine driven if there is a use for the low pressure exhaust steam from the turbines. Otherwise the steam must be vented to a condenser or to atmosphere, which reduces the economic benefit.

Soot Blowing

Soot blowing is required on boilers burning solid and liquid fuels but not on gas-fired boilers. The two blowing mediums are steam and air, with both being equally effective in deposit removal. The air pressure required at the soot blower head is usually in excess of the available plant air. Therefore, a separate compressor must be installed with an integrated piping system around the boiler. Steam soot blowing systems are usually supplied from the boiler drum through a pressure reducing station so that superheated steam is delivered to the soot blower head. Economics usually favour the use of steam for soot blowing.

Environmental Equipment

Ash Handling Equipment

All solid fuels produce ash that must be removed from the boiler. The ash is in bottom ash and fly ash forms. Bottom ash is from the coarse particles of slag that fall into the ash pit under the combustion chamber. Fly ash is the fine ash that is carried with the flue gas, and deposits in the hoppers beneath the economizer, air heater, dust collector and precipitator. The ash is conveyed from the pit and hoppers either to a silo, where it can be periodically removed by truck, or directly to an ash pond adjacent to the boiler plant. The conveying can be achieved mechanically, or by mixing the ash with air or water and blowing or pumping the mixture. Electrical energy is expended on drives for conveyors, pumps, compressors or blowers, and care should be taken in the operation and maintenance to ensure that system energy is minimized.

Air Pollution Control Equipment

These systems are designed to reduce fly ash (particulates), sulphur oxide and nitrous oxide emissions from the boiler plant. Equipment use or nonuse and selection are influenced by government environmental regulations. This equipment is not usually required on small boilers firing natural gas or oil. All solid fuel firing boilers will require at least one of the following types of pollution control equipment.

- *Mechanical cyclone collectors* (dust collectors) remove particulates by centrifugal and gravitation forces developed in a vortex separator. Their use is now limited to small stoker-fired units because of their low collection efficiency of very small particles.
- *Electrostatic precipitators*, electrically charge suspended particles in the gas and then attract them to collecting plates with an electric field. The collecting plates are then rapped to cause the particles to drop into hoppers. Precipitators can be designed for a high collecting efficiency of 98 per cent or more.
- *Fabric filters, or baghouses*, have a long history of applications in dry and wet filtration processes to recover chemicals or control stack emissions. The dirty gas is passed through fabric filters with the particulate matter forming a cake on the fabric. The deposit is periodically removed from the filter by mechanically shaking the fabric, or by a pulse of air. Fabric filters can be designed for collecting 99 per cent of particulates or more.
- *Lime or limestone scrubbing* is the oldest method of removing sulphur dioxide from flue gas. The boiler flue gas enters a Venturi scrubber and contacts the injected absorbent lime slurry. The flue gas then passes through a vertical spray tower where the slurry and absorbed sulphur compounds are washed out of the gas.

All items of pollution control equipment use varying amounts of electrical energy that significantly increase the energy used per plant output. It is imperative that operation and maintenance staff keep this equipment in first rate working order.

Heat Recovery

Heat recovery takes the form of removing heat from the flue gases leaving the boiler or from the blowdown water. This heat is normally used to heat combustion air, feedwater, or treated water.

Air Preheaters

Air preheaters heat the incoming combustion air with the hot flue gas leaving the boiler. Tubular recuperative and regenerative airheaters are the principal types.

The principle of the regenerative heater is shown schematically in Figure 22. Heat is transferred by a regenerative surface that is alternatively rotated through the gas and combustion air streams. The heating surfaces are alternately heated by the flue gas and then cooled by transferring heat to the combustion air. The speed of rotation is very slow (1 to 3 RPM) to ensure maximum heat transfer and minimize leakage of air into the gas.

Additional energy is required to drive the rotating elements, and for the fan(s) to overcome the resistance of the heating surfaces. As the air-side of the heater is always at a higher pressure than the gas-side, leakage of air to the gas will always be present. The operator must ensure that the seals are well maintained since severe leakage will increase the air and gas capacity requirements and the fan energy. Air heaters are subject to “cold-end deposition”, where the fly ash combines with moisture and sulphur derivatives to form a fine-grained deposit on the elements at the “cold-end” of the heater, i.e. on the surfaces closest to the cold air inlet. The operators must regularly use the airheater soot blowers to minimize deposits. Buildup of deposits requires extra fan energy to overcome the increased flow resistance.

Recuperative airheaters are shell and tube heat exchangers where the hot gas flows through the inside of the tubes, and the air over the outside. They require additional energy for the fan(s) to force the air and draw the gas over the heating surfaces. Unlike regenerative types, there is no leakage of air to the gas side. However, they have similar “cold-end” problems that require the operating staff to regularly use the soot blowers.

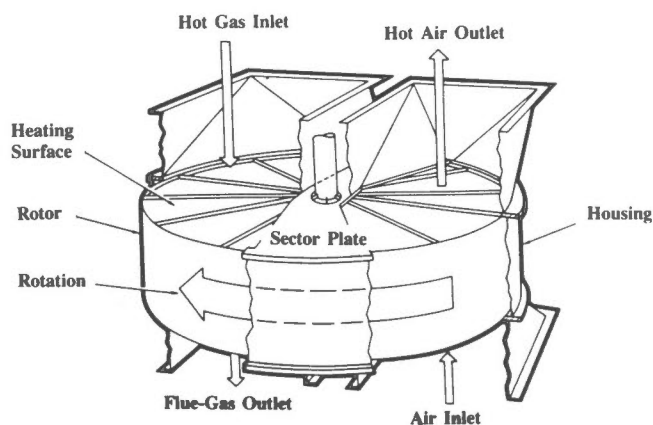

Regenerative Air Preheater
Figure 22

Courtesy of Combustion Engineering, Inc.

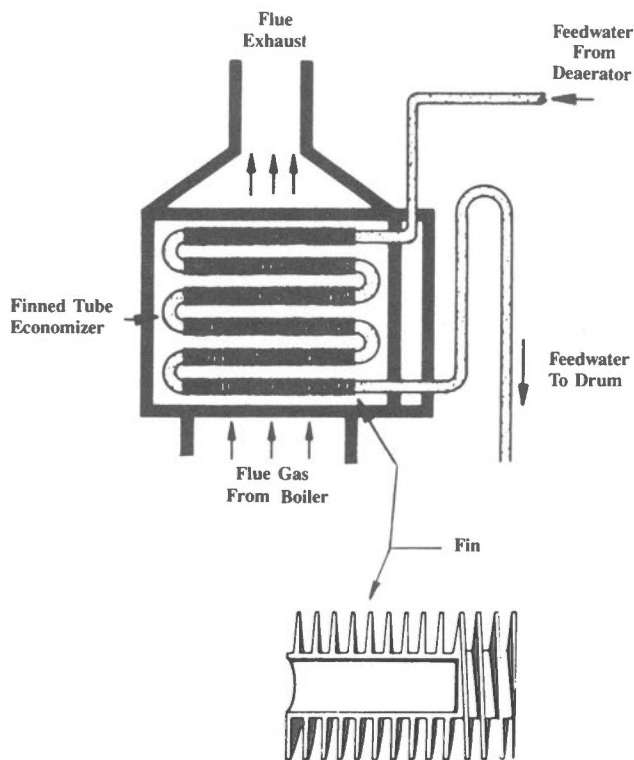

Economizer
Figure 23

Economizers

Economizers improve the boiler efficiency by extracting heat from the flue gas leaving the boiler, and transferring it to the feedwater (Figure 23). Economizers can be positioned inside the main boiler casing or separately cased and supported outside the boiler. The tubes are plain steel or finned to improve heat transfer. In coal or oil fired boilers, the fins are wide-pitched to minimize the effect of ash deposits. Economizers require additional energy for the boiler feed pump to force the feedwater through the economizer tubes, and for the boiler fan(s) to force the air and draw the flue gas. Economizers are subject to the same cold-end problems as air heaters. Care must be taken to ensure that the soot blowing is preventing the buildup of deposits on the outside of the economizer tubes. This can be confirmed by visual examination through observation doors.

Flue Gas Condensers

Flue gas condensers remove more sensible heat from the flue gas than standard boilers with economizers or air preheaters. They also remove some latent heat which results in significant energy savings. The latent heat of water vapor contained in flue gas is equivalent to about 10 per cent of the HHV of natural gas. Only sensible heat is recovered until the natural gas flue gases are cooled to approximately 55°C. Figure 24 demonstrates the rapid flue gas loss reduction that occurs as the dew point is reached and latent heat is recovered. These systems may take the form of indirect condensing or direct contact heat recovery systems.

Indirect condensing systems are designed so that the flue gases are not in contact with the water that is removing the heat from the gases (Figure 25A).

Direct contact condensing systems cool the flue gas by spraying water in a tower arrangement (Figure 25B). There are different tower designs, but they are basically the same as scrubbers that are sometimes used to clean the gases. Flue gas condensers can be used most confidently on a natural gas fired installation because the condensed water vapor is less acidic.

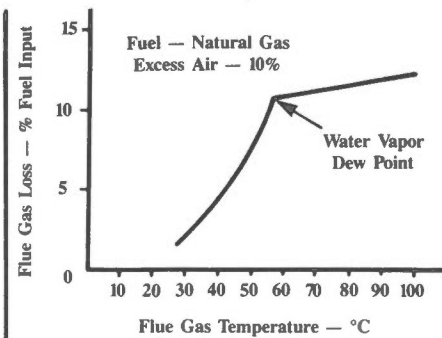

Total Flue Gas Loss Using A Flue Gas Condenser
Figure 24

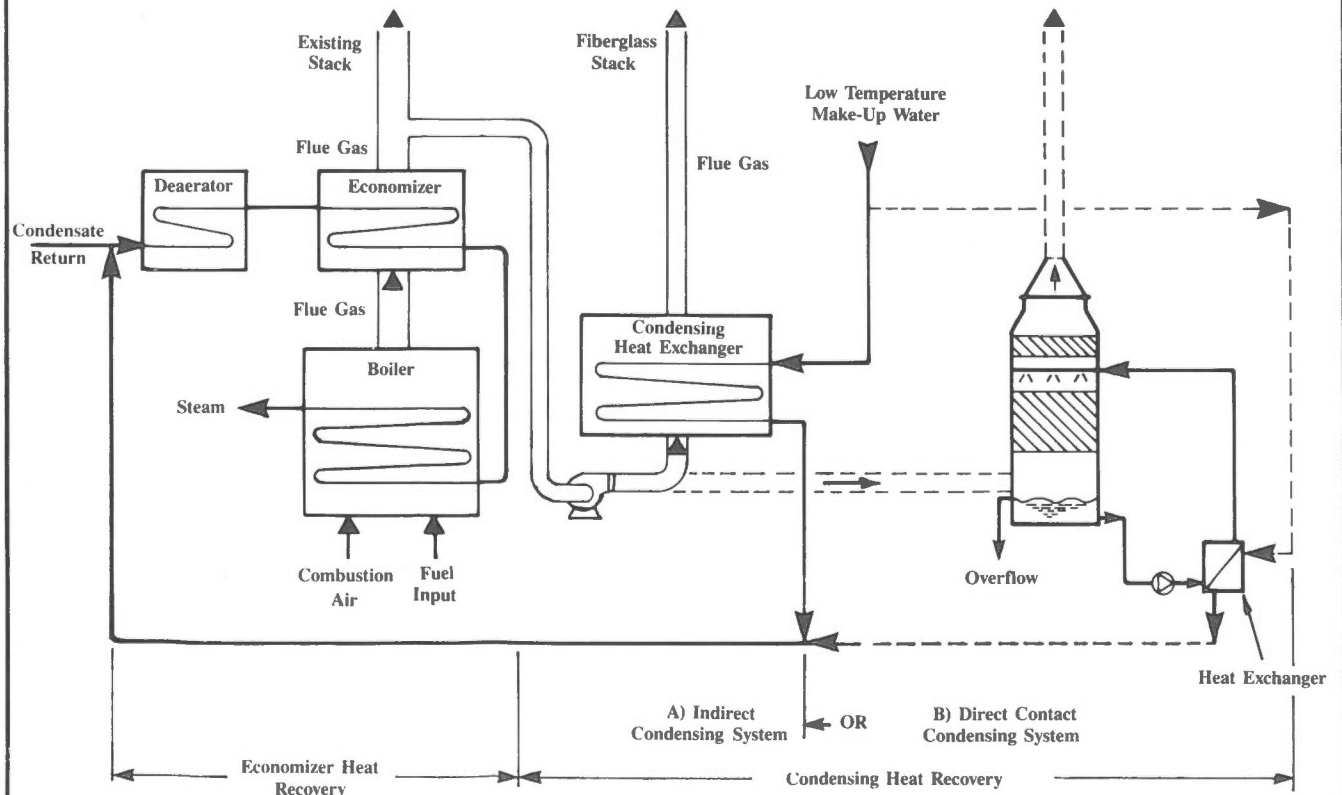
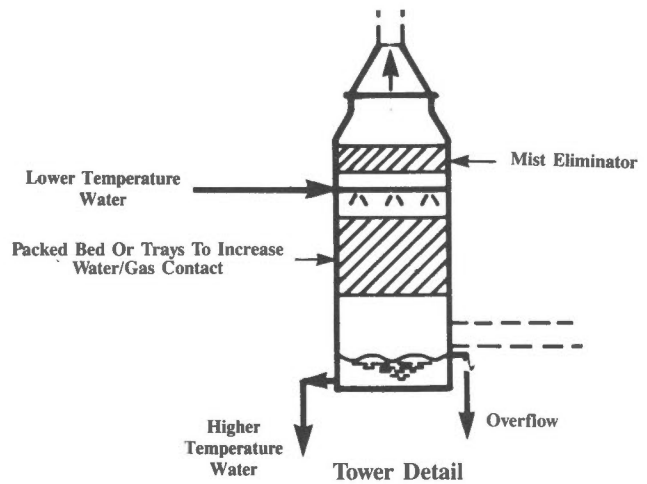

Heat Recovery Systems
Figure 25

Blowdown Heat Recovery

Flash steam, resulting from blowdown, is normally fed to the deaerator so that this energy is saved. However, the residual water contains heat which may be discharged to the sewer. Some of this energy can be recovered by passing the water through a heat exchanger before discharging it to the sewer.

Feedwater and Condensate Handling

A feedwater conditioning and handling system must continuously satisfy certain conditions to discourage operating problems.

- Keep suspended and dissolved solids, and sludge in a form that can be removed through blowdown.
- Reduce corrosion by preventing the buildup of oxygen and carbon dioxide in the water.
- Control water pH.
- Prevent foaming conditions within the drum which allow water carryover with the steam.

A typical boiler feedwater system is shown in Figure 26.

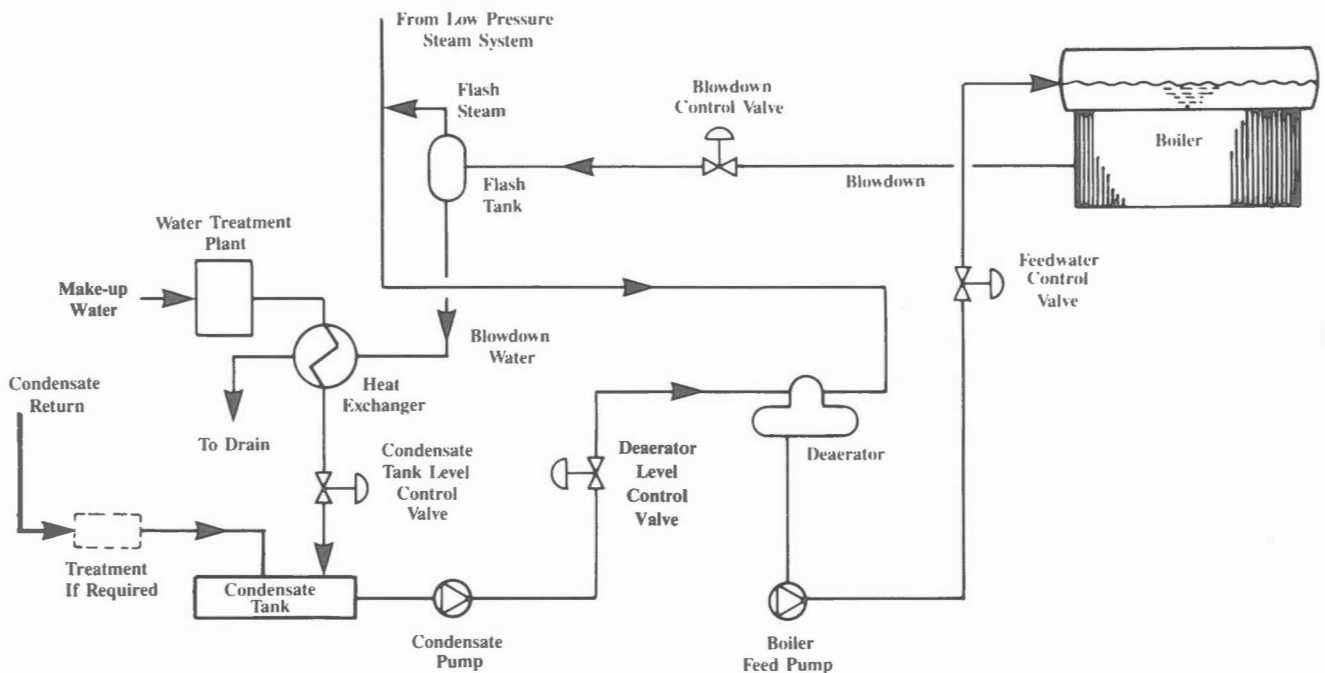

Typical Boiler Feedwater System

Figure 26

Softeners

The chief source of scale in boilers is water hardness from the presence of calcium and magnesium salts. Various softening processes are available for treating the boiler make-up water. These include the hot lime-soda process, hot-process phosphate softening, and a hot-lime zeolite softener. The softening process requires energy in the form of pumping power. For maximum softening efficiency low pressure steam is also required. However, the steam energy is recovered in the feedwater.

Dealkalizers

Dealkalizers remove alkalinity in the form of bicarbonates from the raw water make-up. Bicarbonates break down into carbonates and CO_2 . CO_2 leaves the boiler with the steam and forms acidic condensate, which causes corrosion of the condensate piping system.

A split stream dealkalizer is a common method of reducing alkalinity and hardness. Another type of dealkalizer is the chloride-anion system.

Demineralization

In demineralization, ion exchange removes ionized mineral salts. Demineralization can yield pure water required by high pressure boilers. The process does not require heat energy, but it requires significant pumping power.

Deaerators

Noncondensable gases cause corrosion in the feedwater and condensate systems. The deaerator, which is the final stage of feedwater treatment, removes noncondensable gases such as O₂ and CO₂ from the feedwater. The water fed to the deaerator is a mixture of returned condensate and treated make-up water. Both may be taken to the deaerator separately, or they may have been previously mixed in a condensate receiving tank and then pumped to the deaerator.

The deaerating process is started by steam heating the incoming water to saturation temperature. The separated gases are vented through the top of the deaerator, and the heated and deaerated water falls into a storage tank under the deaerating head. Deaerators usually operate slightly above atmospheric pressure. This results in the deaerated water being fed to the boiler at about 105°C. Some older plants have deaerators operating at a slight negative pressure, which requires a vacuum pump to remove the gases. The energy required by the deaeration process is the power needed to pump the water and condensate to the deaerator and the steam to perform the deaerating process. The steam energy is recovered in the feedwater.

Condensate Tanks

Condensate tanks are designed to hold the returned condensate and treated make-up water. Receivers can be pressurized or vented to atmosphere. Vented tanks lose from 2 to 10 per cent of the heat in condensate as flash steam. The cost of the treated boiler water that must be replaced and pumping costs must also be considered. A pressurized tank avoids these losses, but a low pressure steam system must be available to absorb the vented steam. An alternative is to cool the condensate with cold make-up water to reduce or eliminate flashing of the condensate.

Flash Tanks

Flash tanks are used to separate condensate and flash steam produced when condensate is reduced in pressure. This may be done so that plant discharges can be reduced to atmospheric pressure before being disposed as effluent or to produce quantities of low-pressure steam for heating or deaerating purposes. If a plant discharge produces a consistent flow of significant quantities, some attempt should be made to recover heat by using the flash steam to heat domestic or service water.

Chemical Injection Equipment

Residual hardness can be removed from the boiler water by the injection of phosphate compounds into the feedwater or boiler drum. These chemicals convert calcium and magnesium salts to their respective phosphate compounds that are readily dispersed and removed by blowdown. The equipment involved includes a mixing tank, and a pump capable of injecting small quantities against the boiler pressure.

Chemical agents are sometimes pumped into the feedwater to remove small residual quantities of O₂.

Automation Systems

Some form of monitoring and automation equipment is usually present within boiler plants, but the form and quantity varies substantially. Energy losses can be significant and measurements are required to quantify the energy performance and to expose deterioration in the operation. The combination of measurement data and automatic control can provide operational benefits.

- More precise and consistent operation to maintain the optimum conditions established during boiler testing.
- Automatic control permits operating personnel to be freed from the task of continuously adjusting variables to satisfy changing demand conditions so that they can be more effective in monitoring the efficiency of the overall operation. Personnel will also have more time available for equipment maintenance.
- Automation improves the safety aspects of the boiler plant operation.
- The proper use of automation can improve the boiler plant energy utilization, reduce operating costs and save dollars.

There are many types of automation hardware that can be used to approximately achieve the same results. Examples of this would be the possible use of on-off control, pneumatic or electronic modulating control, programmable controller, microprocessor or minicomputer. Measuring, Metering and Monitoring, Module 15 and Automatic Control, Module 16 would be useful references for this subject.

Safety Systems

This is the first level of automation to consider since it affects the safe operation of equipment and personnel safety. Minimum safety requirements are established by regulatory bodies and insurance companies. Requirements will be influenced by the type and size of boiler, number of burners and the fuel. An overview of potential safety system features follow.

- *Steam drum safety relief valve* designed for full boiler capacity and set to relieve at a fixed pressure above the operating value.
- *Burner management system* which often incorporates several safety features. This system must satisfy regulatory body requirements and could include the boiler purge with air prior to admitting fuel to the burner, confirmation that the fuel valve and air dampers and registers were in the correct position prior to light-off, operation and confirmation of the pilot system, opening of the fuel shut-off valve and confirmation that the main flame was established. The burner flame would then be continuously monitored to ensure safe operation. Several interlocks are usually designed into the system to anticipate problems before they result in an unsafe condition. Representative of these boiler operating parameters are fuel supply conditions, atomizing steam if applicable, combustion air supply conditions, furnace pressure, and low drum water level.

Combustion Control Systems

The choice of combustion control is extremely important because it influences the safe and efficient operation of the boiler. The major classifications of systems are described below.

- *Two or three position control systems* are the most basic and least expensive. With 2-position control (Figure 27A), the firing operation is initiated by a pressure switch for a steam boiler or a temperature switch for a hot water generator. The burner fires at the full rate or else is off. This is the least efficient control since in the firing position the boiler may be operating slightly beyond the optimum point and while “off” the heat transfer surfaces are cooled by air which is drawn through the unit by the stack effect. The 3-position system operates at off, low and high firing rates which tend to reduce “off” position inefficiencies while also controlling the steam pressure better.
- *Modulating control* means that the boiler can continuously operate at any firing rate between minimum and maximum firing capability to satisfy steam demand. This tends to better match the energy input with the boiler output demand at all times and is generally more efficient than 2 or 3 position control. The variety of modulating systems has evolved primarily to improve the combustion efficiency on a continuous basis, but also to satisfy severe steam demand requirements.

With a *parallel modulating control system* the fuel valve and combustion air dampers respond in unison to steam demand in accordance with a predetermined relationship which repeats within limits (Figure 27B). The dampers are schematically shown in the fan discharge duct but they usually position the louvres that adjust the air flow into the fan.

A *metered modulating control system* is one where the fuel and air are initially paralleled as in the previous example to respond to steam demand, but a fuel flow/air flow relationship is used to fine tune the parallelling to better maintain the combustion test conditions (Figure 27C). A further refinement would be a feature known as “cross-limiting”. This uses the measured air flow to limit the fuel flow to the amount which can be safely burned. It also increases the air flow to the amount which is required to safely burn the measured fuel flow. This method of control has the following advantages:

- The rate of increase of fuel flow on a load increase is limited to match the rate of increase of air flow.
- The rate of decrease of air flow on a load decrease is limited to match the rate of decrease of fuel flow.
- At high loads, the rate of firing is limited by the combustion air system capacity, not the fuel system capacity. This prevents operation at high fuel-air ratios which may produce dangerous firing conditions.
- There is a measure of protection against the danger of a fuel control valve sticking open because the system will increase the air flow to conform to the metered fuel flow.

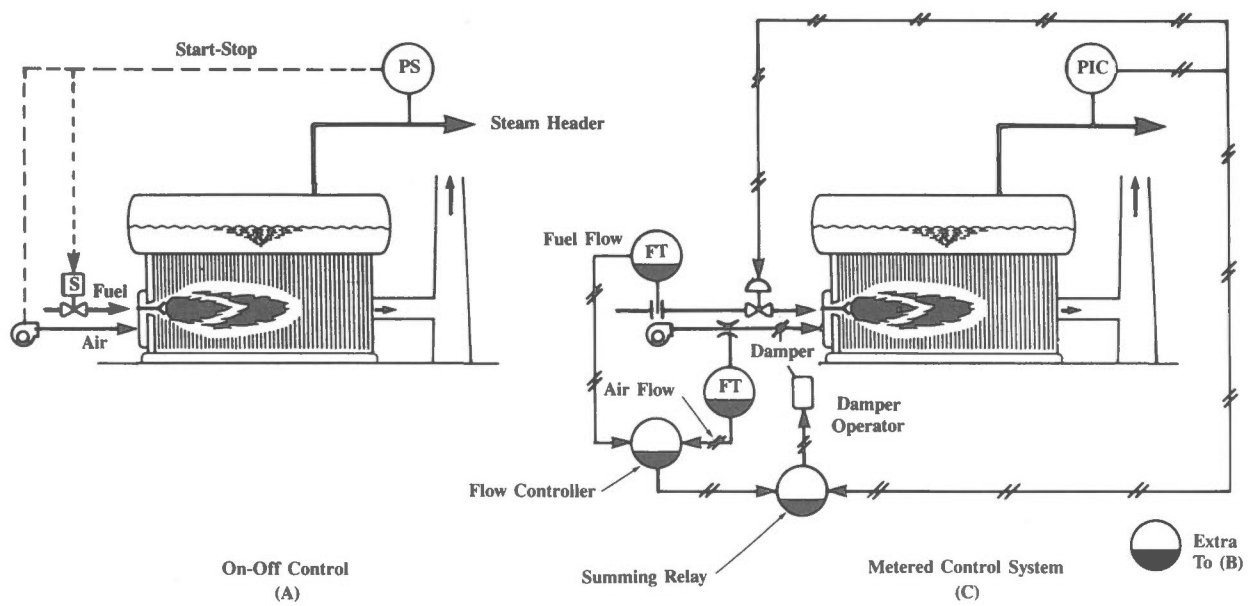

PIC Pressure Indicating Controller FT Flow Transmitter PS Pressure Switch

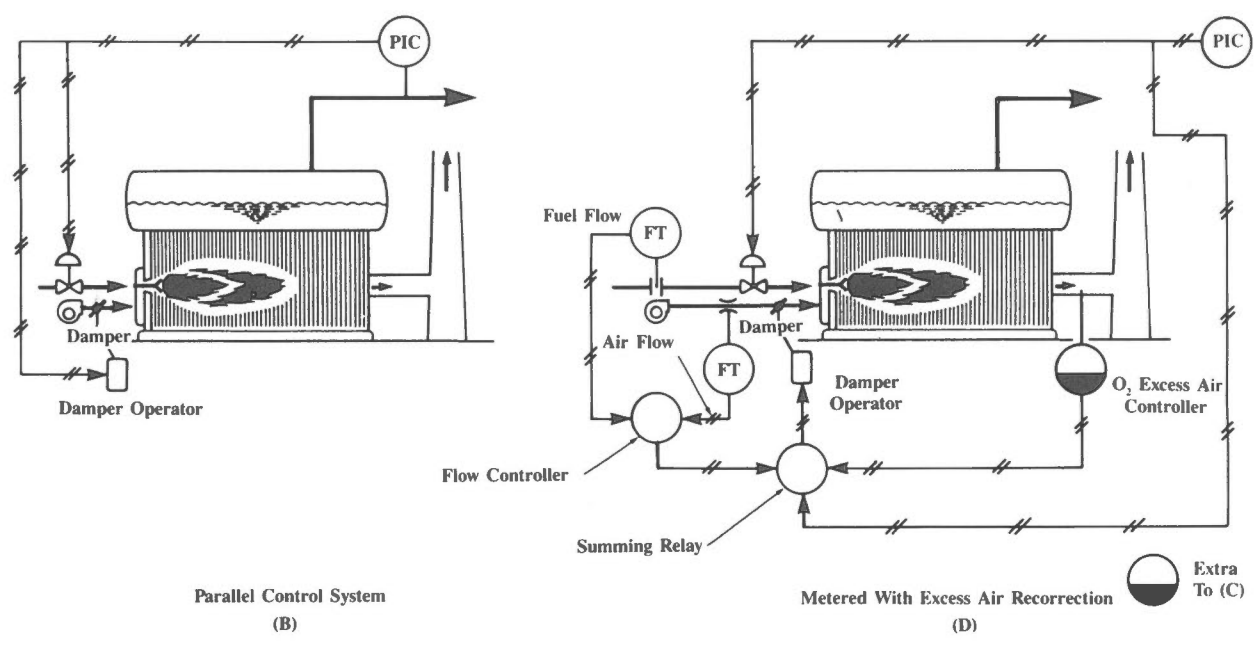

Combustion Control Systems
Figure 27

A further refinement can be incorporated into parallel or metered control systems. It uses the analysis of the combustion flue gas as the final measure of combustion effectiveness (Figure 27D). This is referred to as an *excess air recorection* system. O₂, CO₂ and CO have all been used as the index of combustion efficiency. O₂ recorection is the most common type. CO₂ should not be used because the same value can occur when there is a deficiency of air or when the excess air is correct. If CO is used, it is maintained at very low mg/kg (CO to flue gas) values, but the high cost analyzer is a disadvantage. Excess air recorection is the ideal method because it is a true final measure of the combustion effectiveness. In other words, regardless of whether dampers slip, metering conditions change to introduce flow measurement errors or other variations occur, gas analysis is still a good final measure of the combustion process. A gas analysis measurement can be used to allow the operator to manually trim the excess air or it can be introduced as an automatic recorection to the controls. In the latter case, the optimum flue gas analysis for all firing rates is “programmed” into the controls and compared to the actual value and the fuel/air ratio is then automatically trimmed to achieve the ‘programmed’ value. (Use of the word “programmed” is not to suggest that computer hardware is required although it could be used).

Retrofitting a boiler combustion control system can represent an opportunity to reduce operating energy costs. The savings potential will depend upon the ability of the existing hardware and the potential ability of new control systems to be adjusted for efficient conditions and to maintain them for extended periods of time.

Feedwater Control Systems

The purpose of a feedwater control system is to maintain adequate water in the drum regardless of the steam demand and firing rate. The description of these systems is briefly described below.

- Small boilers sometimes have an *on-off level control system* which starts a feedwater pump on low drum level and stops it at high level. This is the least expensive and most inefficient system.
- Most boilers are equipped with *modulating drum level control*, but this classification can in turn be divided into three distinct systems. The first is a *single element system* whereby the incoming feedwater is controlled from drum level only. This can take the form of a mechanical, pneumatic or electronic control system which is normally restricted to units of 15 000 kg/h capacity with generally steady loads. A *2-element system* employs drum level and steam flow measurements. The steam flow signal helps to anticipate demand changes and thus feedwater requirements. A *3-element system* adds the measurement of feedwater flow to the 2-element system. This compensates for feedwater supply variations and the shrink and swell effect of the boiler water level during severe load changes.

Monitoring Systems

The term *monitoring* refers to the act of observing the overall boiler plant equipment operation plus the actual measurement data available.

Regular monitoring of the boiler plant variables is an essential part of consistently maintaining energy efficient conditions. Combustion is a complex process which is dependent on a large number of interacting boiler plant variables. Thus, the possibility for combustion air and fuel conditions or equipment to change and alter the combustion efficiency must always be anticipated. A significant large change would be obvious, but a gradual change might only be detected quickly as a result of good consistent monitoring habits by operating personnel.

There is a variety of monitoring equipment available to assist operating personnel in the task of ensuring that efficient operation is being achieved.

- An annunciator is an alarm system that brings undesirable conditions to the operator’s attention by means of audible and visual signals.
- Combinations of indicators and recorders are used to display important information.
- Totalizers are often provided for steam and fuel flows so that the direct boiler efficiency can be calculated.
- Data loggers can be used to automatically scan measured variables to provide alarming features, shift operation summaries and trend recording of critical variables.
- Microprocessors can be provided as a strict monitoring tool or as a combination burner management, combustion and feedwater control plus monitoring system. These systems provide management and operating personnel with performance profiles of each boiler and the complete plant.

Cogeneration Systems

Cogeneration can be defined as the simultaneous generation of electrical power and process heat. The most common example is the back-pressure or extraction steam turbine-generator. Another example is a gas turbine connected to an electric generator, with steam being raised by a heat recovery boiler absorbing the heat in the turbine exhaust gases. In these cases, the boiler could deliver steam direct to the process or via a back-pressure turbine.

Gas turbine exhaust contains 75 to 80 per cent of the oxygen found in free atmospheric air. It can therefore supply sensible heat and combustion air to the boiler. The resultant saving of fuel at the steam generator can be considered as a reduction of the heat rate (input per kWh of electrical output) of the gas turbine. In almost all cases, this will result in a heat rate of about two-thirds the heat rate of the most efficient electrical utility generating plant.

Small boiler plants are sometimes designed for a higher pressure than that required by the plant process. Raising the boiler pressure and passing the steam to process through a small turbine generator may give a low cost supply of electricity for a modest increase in boiler fuel.



ENERGY MANAGEMENT OPPORTUNITIES



Energy Management Opportunities is a term that represents the ways that energy can be used wisely to save money. A number of typical Energy Management Opportunities, subdivided into Housekeeping, Low Cost, and Retrofit categories, are outlined in this section to illustrate potential energy savings. This is not a complete listing of the available opportunities. It is intended to provide ideas for management, operating and maintenance personnel to identify other opportunities that are applicable to a particular facility.

Housekeeping Opportunities

Implemented housekeeping opportunities are energy management actions that are done on a regular basis and never less than once a year. This includes activities such as efficient operation, regular maintenance and troubleshooting.

Operation

1. Regularly check water treatment procedures.
2. Maintain the total dissolved solids (TDS) of the boiler water suitably low.
3. Operate at the lowest steam pressure or hot water temperature that is acceptable to the distribution system requirements.
4. Condition fuel for optimum combustion.
5. Minimize load swings and schedule demand where possible to maximize the achievable boiler efficiencies.
6. Regularly check the efficiency of boilers.
7. Regularly monitor and compare performance related data.
8. Regularly monitor the boiler excess air.

Maintenance

1. Keep burners in proper adjustment.
2. Overhaul the seals of regenerative airheaters during scheduled boiler shutdowns.
3. Check for and repair leaking flanges, valve stems and pump glands.
4. Maintain tightness of all air ducting and flue gas breeching.
5. Check for "hot spots" on the boiler casing that may indicate deteriorating boiler insulation that should be repaired during the annual shutdown period.
6. Keep the fireside surfaces of boiler tubes clean.
7. Replace or repair missing or damaged insulation.
8. Replace boiler observation or access doors, and repair any leaking door seals.
9. Replace or repair any leaking or malfunctioning steam traps.
10. Periodically calibrate measurement equipment and tune the combustion control system.

Operation Examples

These are items that should become part of the normal operating routine.

1. Recommended water treatment procedures must be consistently followed to avoid scale build up. This applies to the chemical injection procedures in addition to the treatment of the make-up water. Because scale build up occurs on unseen heating surfaces, the operator will be unaware of the occurrence until a tube ruptures. Up until that time, the fuel wasted could amount to an additional 1 per cent for a considerable length of time.

- It is important that the recommended level of total dissolved solids (TDS) in the boiler water be maintained by proper blowdown procedures to prevent carry-over of solids by the steam. However, it is equally important that the blowdown rate not be excessive.

Example: A packaged watertube boiler is generating 10 000 kg/h of steam at 1500 kPa(absolute) and 240°C, from feedwater at 105°C by firing 805 L/h of No. 2 oil with an HHV of 38.68 MJ/L. The drum pressure is 1600 kPa (absolute) which establishes the acceptable boiler water condition. The minimum required blowdown rate is 5 per cent, but the actual rate is 10 per cent. The wasted heat can be calculated.

Enthalpy of boiler water at 1600 kPa(absolute) 858.6 kJ/kg

Enthalpy of feedwater at 105°C 440.17 kJ/kg

$$\begin{aligned} \text{Heat loss in excess blowdown} &= 10\,000 \times (0.10 - 0.05) \times (858.6 - 440.17) \\ &= 209\,215 \text{ kJ/h} \end{aligned}$$

$$\begin{aligned} \text{Heat loss as percentage of fuel input} &= \frac{209\,215}{805 \times 38.68 \times 1000} \times 100 \\ &= 0.67\% \end{aligned}$$

- Any reduction in pressure and temperature at the outlet of the boiler will result in decreased fuel input. The operator should check with the end user of the steam or hot water to determine if a reduction can be tolerated. Before any change is adopted, it should be referred to the boiler manufacturer for comments and approval, as such changes could interfere with the boiler water circulation.
- Proper fuel conditioning procedures must be maintained. For example, an increase in the viscosity of No. 6 oil because of faulty operation of the oil heating equipment, will result in extra pumping energy and less efficient combustion.
- The heat surfaces must be kept clean through regular soot blowing and tube monitoring. If no visible improvement to the cleanliness of the surfaces is observed after soot blowing the operator must change the sequence, timing and duration of the soot blowing until satisfactory improvement occurs.
- Rescheduling of steam consumption can eliminate inefficient load swings and low load operation. It may be possible to operate a boiler at maximum load every other day instead of 50 per cent continuously. Alternatively, the load may be switched to a smaller boiler that can operate near full load continuously.
- The boiler efficiency should be calculated regularly, by either the input-output or the indirect losses method.
- Operational logs should be used to regularly compare the performance with that achieved in the past.
- Check the excess air and other constituents in the flue gas regularly. A continuous monitor is best, but the capital cost of this equipment is high. Sampling tests by Orsat or other chemical means can be a reliable guide to the existing combustion conditions. Readjustment of the burners or the air-fuel ratio should be performed promptly if high excess air or the presence of carbon monoxide is detected. Figure 13 demonstrates the impact of a deficiency or excess of combustion air on the boiler losses.

Maintenance Examples

These are items that should be done on a regular basis, and never less than once a year. They may be considered to be part of preventive maintenance procedures.

- Maintain proper burner adjustments.* It is a good idea to have an experienced burner manufacturer's representative adjust the burners. The operator can then identify the appearance of a proper burner flame for future reference. The flame should be checked frequently, and always after any significant change in operating conditions.
- Overhaul regenerative air heater seals.* Excessive amounts of air can leak from the air side to the gas side of the air heater if the seals are in poor condition. This results in increased forced draft fan power consumption and may reduce the maximum boiler capacity.

3. *Repair leaking flanges, valve stems and pump glands.* Prompt attention to steam and water leaks will not only save energy but may also prevent costly damage to the stems and flange faces because of high velocity steam or water jets from the points of leakage.
4. *Maintain tightness of air ducting and gas breeching.* Leakage of air out of the air ducts will impose an extra load on the forced draft fan. Leakage of gas will not affect the forced draft fan, but it may cause hazardous operating conditions inside the boiler room. If an induced draft fan is used, any leaks in the gas breeching will draw air into the flue gas system which will increase the load on the induced draft fan.
5. *Check boiler casing for hot spots.* “Hot spots” are an indication of excessive heat losses from the boiler enclosure. The temperature of the surface of the outer skin should not be more than 50°C, although higher temperatures may be unavoidable where insulation cannot be installed, such as around the burner assembly. Eliminating hot spots is a safety measure, and will help to maintain comfortable working conditions.
6. *Replace or repair missing and damaged insulation.* Substantial quantities of heat are lost from bare steam and hot water lines.
7. *Replace boiler doors and repair leaking door seals.* Leakage of air or gas will create the same problems as described in Example 4. In addition, an open furnace door will cause considerable heat loss by radiation of heat from the furnace to the outside. There is also a danger that a furnace upset will cause hot gas to be ejected suddenly through the opening to create a personnel safety hazard.
8. *Repair malfunctioning steam traps.* Steam traps may fail in the open or the shut position. An open steam trap will pass excessive quantities of steam to increase the heat loss. A closed trap will not permit condensate to escape. If the trap is connected to a heat exchanger, the heat exchanger will gradually fill with condensate and eventually fail to operate. If the heat exchanger is heating outside air, the condensate may freeze in winter and damage the tubes of the unit. If the closed trap is draining a steam line, excessive condensate may build up in the line to cause water hammer in the system. This may damage fittings and equipment. A regular steam trap maintenance program is a very positive step toward minimizing energy losses.
9. *Calibrate and tune measurement and control equipment.* A common cause of deteriorating boiler efficiency is operation at higher excess air values than necessary. If the combustion control system is not operating properly there is a tendency to increase the air flow to ensure that the fuel-air ratio will not become excessive for load changes or upset conditions. If the fuel-air ratio is too high, meaning that there is a deficiency of combustion air, there is a possibility of unstable combustion conditions which could lead to a furnace “puff”. A properly operating combustion control system will permit operation at the lowest attainable excess air level while maintaining proper combustion during load changes. Typically a reduction in the excess air from 20 to 10 per cent will increase the efficiency 1.5 per cent.

Low Cost Opportunities

Implemented low cost opportunities are energy management actions that are done once and for which the cost is not great. This creates a separation from the housekeeping activities which must be repeated regularly.

Some of the potential low cost energy saving opportunities in boiler plants are listed below.

1. Install performance monitoring equipment.
2. Relocate combustion air intake.
3. Recover blowdown heat.
4. Add insulation.
5. Reduce boiler excess air.

Low Cost Examples

1. Install Performance Monitoring Equipment

Minimum monitoring instrumentation should provide the ability to determine the boiler energy input and output. The fuel meter or wattmeter could be a portable instrument used for several boilers. Additional instruments would be required to measure the flow, pressure and temperature at the boiler outlet, and the temperature of the boiler feedwater. Flue gas temperature and gas analysis should be used to determine the flue gas loss. If an airheater or economizer is used to recover heat from the flue gas, temperature measurements of gas and air in and out could be used to check the performance.

2. Relocate Combustion Air Intake

The combustion air intake can sometimes be relocated to the top of the boiler house to use heated air and save energy.

Example: A boiler firing No. 2 oil uses 14 500 kg/h of air at 20°C average temperature. Installation of a duct to the top of the boiler house increases the average air temperature to 30°C. The specific heat of the air is 1.01 kJ/kg.°C.

$$\begin{aligned}\text{Heat recovered} &= 14\,500 \text{ kg/h} \times (30 - 20)^\circ\text{C} \times 1.01 \text{ kJ/kg}\cdot^\circ\text{C} \\ &= 146\,450 \text{ kJ/h}\end{aligned}$$

The boiler operates 6000 hours per year, and the fuel costs \$5/GJ.

$$\begin{aligned}\text{Annual fuel savings} &= \frac{146\,450 \times 6000 \times 5}{1 \times 10^6} \\ &= \$4,393 \text{ per year}\end{aligned}$$

The ducting cost is \$10,000.

$$\text{Simple payback} = \frac{\$10,000}{\$4,393} = 2.3 \text{ years}$$

3. Recover Blowdown Heat

Blowdown heat can be recovered by diverting the flash steam to the deaerator and/or putting the blowdown water through heat exchangers to heat the feedwater make-up.

Example: Consider a boiler evaporating 13 500 kg/h of dry saturated steam at 1400 kPa(absolute) with a blowdown rate of 5 per cent. The feedwater is supplied to the boiler at 1500 kPa and 105°C.

$$\text{Enthalpy of boiler water at 1400 kPa(absolute)} \quad 830.1 \text{ kJ/kg} \quad (\text{From Table 2})$$

$$\begin{aligned}\text{Blowdown heat} &= 13\,500 \times 0.05 \times 830.1 \quad (\text{above } 0^\circ\text{C}) \\ &= 560\,317 \text{ kJ/h}\end{aligned}$$

A study of the deaerator steam and feedwater systems shows that 75 per cent of the blowdown heat is recoverable. The boiler operates 5000 hours per year and fuel costs \$5/GJ.

$$\begin{aligned}\text{Annual savings} &= \frac{560\,317 \times 0.75 \times 5000 \times 5}{1 \times 10^6} \\ &= \$10,506\end{aligned}$$

Blowdown heat recovery equipment including a heat exchanger to transfer heat from the blowdown water to treated water make-up, plus the associated piping costs \$15,000.

$$\begin{aligned}\text{Simple payback} &= \frac{\$15,000}{\$10,506} \\ &= 1.4 \text{ years}\end{aligned}$$

4. Add Insulation

Add insulation to areas previously left uninsulated or increase thickness in areas already insulated. Boilers installed 15 to 20 years ago were sometimes insulated for reasons of personnel protection rather than energy conservation. Insulation thicknesses were selected to give an outside casing temperature of 55°C. If additional insulation was added to reduce the skin temperature to 40°C, the energy saving could amount to at least 0.25 per cent of the annual fuel bill. Also, some areas out of the reach of operating staff may not be insulated.

5. Reduce Boiler Excess Air

Reduction in the excess air may be achieved by minor adjustments to the control system, and burner assembly. These changes can be effected at low cost.

Example: A boiler burning natural gas is operating at 60% excess air. Boiler efficiency has been tested and found to be 77%. Annual fuel costs are \$400,000. Recalibration of the controls and minor repairs to the burner windbox dampers cost \$2000. These changes permit operation at 40% excess air.

From Figure 9, it can be seen that a reduction in excess air from 60% to 40% results in a reduction in flue gas losses from 21% to 19% at a flue gas temperature of 210°C. Assuming that other losses and the flue gas temperature remain unchanged, the boiler efficiency will be 79%.

$$\text{Annual fuel cost at 40\% excess air} = \$400,000 \times \frac{77}{79} = \$389,873$$

$$\begin{aligned} \text{Annual savings} &= \$400,000 - \$389,873 \\ &= \$10,127 \end{aligned}$$

$$\text{Payback} = \frac{\$2,000}{\$10,127} = 0.2 \text{ year (2.4 months)}$$

Retrofit Opportunities

Implemented retrofit opportunities are energy management actions which are done once and for which the cost is significant. This section provides a few examples of how the installation of new equipment can contribute to the saving of energy dollars. They usually involve technical changes that can affect the performance and arrangement of plant auxiliaries. It is suggested that the boiler manufacturer or a consulting engineering firm be retained to make an evaluation of the proposed changes. Boiler plant retrofit opportunities are listed below.

1. Install economizer.
2. Install airheater.
3. Install new boiler.
4. Upgrade burner.
5. Install electric coil boiler.
6. Install turbulator in fire tube boiler.
7. Install flue gas condenser.
8. Convert from oil to gas.

Retrofit Examples

1. Install Economizer

The introduction of an economizer into the boiler breeching will increase the pressure drop in the flue gas system. In a forced draft boiler, this may mean the installation of a new forced draft fan, or at least a new impeller and motor. The resultant increase in combustion chamber pressure may necessitate changes to the burner. In an induced draft system, the induced draft fan may be changed, but the combustion chamber pressure and burner will remain the same. There will be an additional water-side pressure loss that may mean a modification to the boiler feed pumps and motors. The temperature of the gas to the stack will be less which reduces the stack draft. Feedwater piping modifications, economizer support, and possible breeching modifications must be evaluated.

Example: The analysis that follows is based on the actual addition of a free standing economizer to a forced draft packaged water-tube boiler producing a maximum of 20 000 kg/h of superheated steam at 3100 kPa(gauge). The natural gas fired boiler operated with 10 per cent excess air, 300°C gas outlet temperature and a tested efficiency of 80 per cent. Before conversion, the boiler's annual fuel consumption was 292 780 GJ at a cost of \$4.24/GJ. The modification included changes to the F.D. fan, burners and feed pump motors. The total cost of the project was reported to be \$158,000 (1984).

$$\begin{aligned}\text{Annual fuel cost before conversion} &= 292,780 \text{ GJ} \times \$4.24/\text{GJ} \\ &= \$1,241,387\end{aligned}$$

After conversion, the excess air was still 10%, but the exit flue gas temperature had decreased to 180°C. From Figure 9, it can be seen that the reduction in the flue gas heat loss would be equal to 4.8 per cent. An additional radiation loss of 0.2 per cent of the fuel input can be allowed for the economizer heat transfer efficiency of approximately 96 per cent. Thus, the heat recovered in the economizer = 4.8 - 0.2 = 4.6 per cent of fuel input.

$$\begin{aligned}\text{Annual steam heat} &= 292\ 780 \times 0.8 \\ &= 234\ 224 \text{ GJ}\end{aligned}$$

$$\begin{aligned}\text{Fuel energy after conversion} &= \frac{234\ 224}{(.80 + .046)} \\ &= 276\ 860 \text{ GJ}\end{aligned}$$

$$\begin{aligned}\text{Annual fuel cost after conversion} &= 276\ 860 \times 4.24 \\ &= \$1,173,886\end{aligned}$$

$$\begin{aligned}\text{Annual fuel savings} &= \$1,241,387 - 1,173,886 \\ &= \$67,501\end{aligned}$$

$$\begin{aligned}\text{Simple payback} &= \frac{\$158,000}{\$67,501} \\ &= 2.34 \text{ years}\end{aligned}$$

2. Install Airheater

When considering an airheater, the burner manufacturer should be consulted to determine the maximum allowable combustion air temperature. This could be as low as 250°C, and it is unlikely to be higher than 400°C since that would require alloy steels instead of carbon steel.

The introduction of an airheater will increase the pressure loss on the flue gas and combustion air systems. A forced draft system, with only a single F.D. fan, may require the installation of a new fan and motor. For a balanced draft system, both fans may have to be replaced, although a new impeller and motor might be sufficient. The forced draft system may also include modifications to the burner, as the combustion chamber pressure will increase significantly. New air and gas ductwork must be installed, and modifications to the stack may be necessary.

3. Install New Boiler

Installing a new boiler to replace an inefficient boiler will make a substantial improvement in fuel economy, particularly if the boiler is constantly operating at loads much lower than rated capacity.

Example: In an actual case history, a gas fired water-tube boiler was originally designed to generate a maximum of 15 000 kg/h of dry saturated steam at 2200 kPa(absolute) from feedwater at 105°C. Through energy conservation measures, the load was reduced to 5000 kg/h for 6000 hours annually. When tested at the reduced load, the efficiency was calculated at 71 per cent. Fuel costs \$4.24/GJ. A new coil-tube boiler, capable of generating 5000 kg/h at the same conditions with an efficiency of 80 per cent was installed at a total cost of \$50,000.

Enthalpy of saturated steam at 2200 kPa(absolute) 2799.1 kJ/kg (From Table 2)

Enthalpy of feedwater at 105°C 440.17 kJ/kg (From Table 2)

$$\text{Old boiler fuel energy} = \frac{5000 (2799.1 - 440.17)}{0.71 \times 10^6}$$

$$= 16.61 \text{ GJ/h}$$

$$\text{Annual fuel cost} = 16.61 \times 6000 \times 4.24$$

$$= \$422,558$$

$$\text{Annual new boiler fuel cost} = 422,558 \times \frac{71}{80} = \$375,020$$

$$\text{Annual savings} = \$422,558 - \$375,020 = \$47,538$$

$$\text{Simple payback} = \frac{\$50,000}{47,538} = 1.05 \text{ years}$$

4. Upgrade Burner

Installation of a new burner assembly may produce energy savings from the reduction of excess air in the flue gas.

Example: A packaged boiler burning natural gas is operating with 40% excess air. It is not possible to reduce the excess air below this level because of the poor mixing of the fuel and air in the existing burner. A new burner assembly, which is guaranteed to operate at 10% excess air, costs \$45,000 installed. Annual fuel cost is \$400,000. Flue gas temperature is 250°C.

From Figure 9, it can be seen that a reduction in excess air from 40% to 10% reduces flue gas losses from 22% to 19%. The corresponding increase in boiler efficiency, allowing 2% for radiation and unmeasured losses, is from 76% to 79%.

$$\text{Annual fuel cost after conversion} = \$400,000 \times \frac{76}{79}$$

$$= \$384,810$$

$$\text{Annual savings} = \$400,000 - \$384,810$$

$$= \$15,190$$

$$\text{Simple payback} = \frac{\$45,000}{\$15,190} = 2.96 \text{ years}$$

5. Install Electric Coil Boiler

For light summer loads, such as the heating of domestic water, it is inefficient to start-up a large boiler and operate it at a very low load. An electric boiler, sized so that it can meet the load operating at or near full capacity, may provide an opportunity for energy and dollar savings.

6. Install Turbulator in Firetube Boiler

In firetube boilers of less than 100 HP, or in those converted from coal to gas or oil firing, the combustion chamber tends to be large in relation to the volume of gas passing through. The heat transfer therefore is less effective, with a resultant decrease in thermal efficiency. A turbulator is a simple spiral plate that is rotated by a small electric motor to induce a swirling action to the combustion gases. The increase in thermal efficiency is claimed to be 3 or 4 per cent of the heat input.

Consider a 70 HP firetube boiler with an annual fuel bill of \$65,000 per year. A turbulator costs \$2,500 to install.

$$\text{Annual fuel savings} = 65,000 \times 0.03 = \$1,950$$

$$\text{Simple payback} = \frac{\$2,500}{\$1,950} = 1.3 \text{ years}$$

7. Install Flue Gas Condenser

A flue gas condenser reduces the temperature of the boiler exit gas below the dew point of the water vapor in the gas, thereby recovering latent heat from the flue gas. The following analysis applies to an actual retrofit of a large commercial greenhouse complex. The heating plant consisted of a 350 HP gas or oil fired coiltube boiler using 12 GJ/h of natural gas at 10 per cent excess air for 4000 hours per year. Fuel costs \$4.24/GJ. A flue gas condenser was installed to reduce the stack gas temperature from 260°C to 50°C. The capital cost of the retrofit amounted to \$22,000.

The recovered heat was used to heat water which otherwise would have been heated by burning natural gas in the boiler at 78 per cent efficiency. A 95 per cent efficient heat exchanger was used to transfer heat from the condenser water.

From Figure 9, the stack loss at 260°C with 10 percent excess air is 19 per cent of the input energy. From Figure 24 the stack loss at 50°C is 7.3 per cent.

$$\begin{aligned} \text{Net efficiency improvement} &= (19 - 7.3) \times .95 \\ &= 11.1\% \end{aligned}$$

$$\begin{aligned} \text{Annual fuel savings} &= 12 \text{ GJ/h} \times \frac{11.1}{(78 + 11.1)} \\ &= 1.495 \text{ GJ} \end{aligned}$$

$$\begin{aligned} \text{Annual dollar savings} &= 1.495 \text{ GJ/h} \times 4,000\text{h} \times \$4.24/\text{GJ} \\ &= \$25,355 \end{aligned}$$

$$\begin{aligned} \text{Simple payback} &= \frac{\$22,000}{\$25,355} \\ &= 0.87 \text{ years (less than 11 months)} \end{aligned}$$

8. Convert From Oil to Gas

The conversion of a boiler from oil to gas firing does not necessarily save energy, but it can result in substantial dollar savings.

Example: A packaged type boiler, rated at 10 000 kg/h, burns No. 2 oil which costs \$.30/L. Annual oil consumption is 2.2 million litres. The conversion cost to natural gas is estimated at \$60,000, including a new burner assembly, new and modified controls, gas piping, and installation labour. The boiler operates with an excess air of 40% and a flue gas temperature of 240°C. For this installation the natural gas costs were \$5/GJ.

Conversion from oil to gas firing means that the boiler efficiency is reduced, because of the higher water vapor losses in the flue gases which result from the combustion of hydrogen in the fuel.

From Figure 10, the total flue gas loss at 40% excess air and 240°C flue gas temperature for No. 2 oil firing is 18%. Radiation and unmeasured losses are approximately 2%. Thus, boiler efficiency is $100 - (18 + 2)\% = 80\%$.

From Figure 9, the total flue gas loss at the same excess air and flue gas temperature when firing natural gas is 21%. Radiation and unmeasured losses are the same at 2%. Boiler efficiency for gas is $100 - (21 + 2)\% = 77\%$.

$$\begin{aligned}\text{Annual oil cost} &= \$0.30 \times 2.2 \times 10^6 \text{ litres} \\ &= \$660,000\end{aligned}$$

The annual cost of pumping oil is \$5,000 so that the total annual cost for it is \$665,000

No.2 oil has a heating value (Appendix C) of 38.68 MJ/L.

$$\begin{aligned}\text{Annual oil energy} &= \frac{2.2 \times 10^6 \text{ L/yr} \times 38.68 \text{ MJ/L}}{1000 \text{ MJ/GJ}} \\ &= 85\,096 \text{ GJ/yr}\end{aligned}$$

Total energy input per year when burning gas will be higher owing to the lower boiler efficiency.

$$\text{Annual gas energy} = 85,096 \text{ GJ} \times \frac{80}{77} = 88,411 \text{ GJ/yr}$$

$$\text{Annual gas cost} = 88,411 \text{ GJ/yr} \times \$5/\text{GJ} = \$442,055$$

$$\begin{aligned}\text{Annual savings} &= \$665,000 - \$442,055 \\ &= \$222,945\end{aligned}$$

$$\text{Simple payback} = \frac{\$60,000}{\$222,945} = .27 \text{ years (3 months)}$$

Further savings could be made by reducing the excess air from 40% to 10% with a better gas burner.

Boiler Efficiency Test
Worksheet 6-1

Company: WORKED EXAMPLE Date: 18/3/85
 Location: _____ By: MBE
 Boiler Number: 2 Fuel Fired: No. 2 OIL
 Rated Capacity: 12000 kg/h Test No. 3 - HIGH LOAD

Pressures & Temperatures

Steam pressure at boiler outlet	<u>1500</u> kPa(abs) (1)
Steam temperature at boiler outlet	<u>240</u> °C (2)
Water temperature at boiler inlet	<u>105</u> °C (3)
Combustion air temperature	<u>20</u> °C (4)
Fuel temperature	<u>20</u> °C (5)
Gas temperature leaving boiler	<u>260</u> °C (6)

Unit Quantities

Enthalpy of steam at boiler outlet	<u>2789.9</u> kJ/kg (7)
Enthalpy of feedwater to boiler	<u>440.17</u> kJ/kg (8)
Heat absorbed per kg of steam (7) - (8)	<u>2349.7</u> kJ/kg (9)
Higher heating value of fuel (state units)	<u>38.68</u> MJ/h (10)

Hourly Quantities

Actual water evaporated	<u>10000</u> kg/h (11)
Rate of fuel firing (state units)	<u>805</u> L/hr (12)
Total heat input (12) x (10)* =	<u>805 x 38.68</u> = <u>31137</u> MJ/h (13)

Total heat output $\frac{(11) \times (9)}{1000} = \frac{10000 \times 2349.7}{1000}$ = 23497 MJ/h (14)

Direct efficiency $\frac{(14)}{(13)} \times 100 = \frac{23497}{31137} \times 100$ = 75.5 % (15)

*Units of (12) x (10) must equal MJ/h

Flue Gas Analysis

	% Volume	
CO ₂	<u>17.8</u>	(16)
O ₂	<u>3.8</u>	(17)
CO	<u>0</u>	(18)
N ₂ by difference	<u>83.4</u>	(19)
Excess air	<u>20</u>	(20)

Heat Loss Efficiency

	% Loss of fired fuel	
Heat loss to dry gas and H ₂ O (Figure 9 for natural gas and Figure 10 for No. 2 oil)	<u>17.2</u>	(21)
Heat loss to radiation (Figure 12)	<u>1.2</u>	(22)
Unmeasured losses	<u>0.5</u>	(23)
Total losses (21) + (22) + (23)	<u>18.9</u>	(24)
Indirect efficiency 100 - (24)	<u>81.1</u>	(25)

APPENDICES

- A — Glossary of Terms**
- B — Tables**
- C — Common Conversions**
- D — Worksheets**



Glossary

Air Infiltration — The leakage of air into a boiler, duct or breeching.

Ambient Temperature — The temperature of air surrounding the equipment.

Ash — The incombustible inorganic matter in the fuel.

Atomizer — A device which reduces a liquid to a fine spray.

Audit, diagnostic — The analysis of a potential opportunity to save energy which could involve the assessment of the current process operation and records, calculation of savings, and estimates of capital and operating costs so that the financial viability of the project can be established.

Audit, walk through — The visual inspection of a facility to observe how energy is used or wasted.

Bag Filter — A device containing one or more cloth bags for recovering particles from the dust laden gas which passes through it.

Base Load — Base load is the term applied to a boiler load that is essentially constant for long periods.

Blowdown — Removal of a portion of the boiler water for the purpose of reducing concentration, or to discharge sludge.

Blowdown, continuous — The uninterrupted removal of boiler water.

Blowdown, intermittent — The blowing down of boiler water at intervals.

Blowdown Rate — A rate expressed as a percentage of the blowdown water to the feedwater flow of the boiler.

Boiler — A closed vessel in which water is heated and steam is generated.

Boiler, electric — A boiler in which electric heating means serves as the source of heat.

Boiler, firetube — A boiler with straight tubes that are surrounded by water and steam and through which the products of combustion pass.

Boiler Water — The water within the boiler.

Boiler, watertube — A boiler in which the tubes contain water and steam, the heat is applied to the outside surfaces of the tubes.

Boiling — The conversion of liquid into vapor.

Breeching — A duct which transports the products of combustion between the boiler and the stack.

Burner — A device which introduces the fuel and air into a furnace at the desired velocities and turbulence to maintain proper combustion.

Burner Windbox — A plenum chamber around a burner in which the air pressure is sufficiently high to ensure proper distribution of air.

Carryover — The chemical solids and liquid entrained in the steam leaving the boiler.

Casing — A covering of metal used to enclose a boiler.

Circulation — The movement of water and steam within a boiler.

Combustible — The heat producing constituents of a fuel.

Combustible Loss — The unliberated thermal energy loss from unburned combustible matter.

Combustion — The rapid chemical combination of oxygen with the combustible elements of a fuel resulting in the production of heat.

Combustion Rate — The quantity of fuel fired per unit of time.

Complete Combustion — The complete oxidation of all the combustible constituents of a fuel.

Condensate — Condensed water resulting from the removal of latent heat from steam.

Control Valve — A valve used to control the flow of fuel or water.

Damper — A variable resistance device for regulating the flow of air or flue gas.

Deaeration — Removal of air and non condensible gases from boiler feedwater prior to its introduction to a boiler.

Dew Point — The temperature at which condensation begins when cooling air or gas.

Dissolved Solids — Those solids in water which are in solution.

Draft — The difference between atmospheric pressure and some lower pressure existing in the furnace or gas passages of a boiler.

Drum — A cylindrical shell closed at both ends that is designed to withstand pressure.

Drum Pressure — The pressure of the steam maintained in the boiler steam drum.

Dry Gas — That portion of flue gas which contains no water vapor.

Dry Gas Loss — The loss representing the difference between the heat content of the dry exhaust gases and their heat content at the temperature of ambient air.

Dry Saturated Steam — Steam containing no moisture at saturated temperature.

Efficiency — The ratio of output to the input. The efficiency of a boiler is the ratio of the heat absorbed by water and steam to the heat in the fuel fired.

Energy Management Opportunities (EMO), housekeeping — Potential energy saving activities which should be done on a regular basis and never less than once per year. This includes preventive maintenance programs.

Energy Management Opportunities (EMO), low cost — Potential energy saving improvements that are done once and for which the cost is not considered great.

Energy Management Opportunities (EMO), retrofit — Potential energy saving improvements that are done once and for which the cost is significant.

Enthalpy — Enthalpy is a measure of the heat energy per unit mass of a material. Units are expressed as kJ/kg.

Evaporation Rate — The quantity of water evaporated in a unit of time.

Excess Air — Air supplied for combustion in excess of that theoretically required for completed oxidation.

Feedwater — Water introduced into a boiler during operation. It includes make-up water and returned condensate.

Feedwater Treatment — The treatment of boiler feedwater by the addition of chemicals to prevent the formation of scale or to eliminate other objectionable characteristics.

Flue Gas — The gaseous products of combustion.

Forced Draft Fan — A fan supplying air under pressure to the fuel burning equipment.

Fuel-Air Ratio — The ratio of the mass or volume, of fuel to air.

Furnace Draft — The draft in a furnace.

Gas Analysis — The determination of the constituents of the flue gas.

Hardness — A measure of the amount of calcium and magnesium salts in water.

Heating Surface — Heating surface is the area of boiler water surfaces which receive heat from the products of combustion.

Higher Heating Value — The amount of heat recovered when the products of complete combustion of a unit quantity of fuel are cooled to the initial temperature of the fuel and air.

Induced Draft Fan — A fan exhausting hot gas from the heat absorbing equipment.

Insulation — A material of low thermal conductivity used to reduce heat losses.

Lower Heating Value — The higher heating value minus the latent heat of vaporization of the water vapor in the products of combustion.

Mechanical Atomizing Oil Burner — A burner which uses the pressure of the oil for atomization.

Orsat — The gas analysis apparatus in which O_2 , CO_2 and CO constituents are measured by absorption.

Perfect Combustion — The complete oxidation of all the combustible constituents of a fuel, utilizing all the oxygen supplied.

Precipitator — An ash separator and collector of the electrostatic type.

Products of Combustion — The gases, vapors, and solids resulting from the combustion of fuel.

Radiation Loss — A term used to account for the conduction, radiation, and convection heat losses from the boiler settings to the ambient air.

Register — The apparatus used in a burner to regulate the direction of combustion airflow.

Saturated Temperature — The temperature at which evaporation occurs at a particular pressure.

Scrubber — An apparatus for the removal of solids and gases from flue gas by entrainment in water, or a chemical solution.

Sludge — A deposit in the boiler water which normally can be removed by blowdown.

Smoke — Small gas borne particles of carbon or soot, resulting from incomplete combustion.

Sootblower — A mechanical device for discharging steam or air to clean heat absorbing surfaces.

Stack — A vertical "duct", which due to the difference in density between the internal hot gas and external air creates a draft at its base.

Steam Atomizing Oil Burner — A burner for firing oil which is atomized by steam.

Theoretical Air — The quantity of air required for perfect combustion. Also called stoichiometric air.

Total Air — The total quantity of air supplied for combustion expressed as a percentage of theoretical air.

Treated Water — Water which has been chemically treated to make it suitable for make-up water

Unaccounted for Loss — That portion of a boiler heat balance which represents the difference between 100 per cent and the sum of the heat absorbed by the unit and all the classified losses expressed as a per cent.

Unburned Combustible — The combustible portion of the fuel which is not completely oxidized.

Water Level — The level of the water in a boiler drum.

COMBUSTION AIR REQUIREMENTS

TABLE 1

Fuel	Theoretical Air Mass kg/GJ As Fired (Stoichiometric Air)	Typical Excess Air (Minimum)	Total Air Mass kg/GJ As Fired
Natural Gas	318	5% *	334
#2 Fuel Oil	323	10% *	355
#6 Fuel Oil	327	10% *	360
Bituminous Coal (40% Volatiles, Moisture & Ash Free Basis)	327	20%	392
Biomass (Pine Wood Bark, Moisture & Ash Free Basis)	315	50%	473

* Note: Burners designed for low excess air firing can permit operation at as low as 1 to 2 per cent excess air.

PROPERTIES OF SATURATED STEAM AND SATURATED WATER (TEMPERATURE)

TABLE 2

Temperature		Press. kPa	Volume, m ³ /kg			Enthalpy, kJ/kg			Entropy, kJ/kg K		
°C	K		Water	Evap.	Steam	Water	Evap.	Steam	Water	Evap.	Steam
<i>t</i>	<i>T</i>	<i>p</i>	<i>v_f</i>	<i>v_{fg}</i>	<i>v_g</i>	<i>h_f</i>	<i>h_{fg}</i>	<i>h_g</i>	<i>s_f</i>	<i>s_{fg}</i>	<i>s_g</i>
0.	273.15	0.6108	0.0010002	206.30	206.31	-0.04	2501.6	2501.6	-0.0002	9.1579	9.1577
0.01	273.16	0.6112	0.0010002	206.16	206.16	0.00	2501.6	2501.6	0.0000	9.1575	9.1575
1.0	274.15	0.6566	0.0010001	192.61	192.61	4.17	2499.2	2503.4	0.0153	9.1158	9.1311
2.0	275.15	0.7055	0.0010001	179.92	179.92	8.39	2496.8	2505.2	0.0306	9.0741	9.1047
3.0	276.15	0.7575	0.0010001	168.17	168.17	12.60	2494.5	2507.1	0.0459	9.0326	9.0785
4.0	277.15	0.8129	0.0010000	157.27	157.27	16.80	2492.1	2508.9	0.0611	8.9915	9.0526
5.0	278.15	0.8718	0.0010000	147.16	147.16	21.01	2489.7	2510.7	0.0762	8.9507	9.0269
6.0	279.15	0.9345	0.0010000	137.78	137.78	25.21	2487.4	2512.6	0.0913	8.9102	9.0015
7.0	280.15	1.0012	0.0010001	129.06	129.06	29.41	2485.0	2514.4	0.1063	8.8699	8.9762
8.0	281.15	1.0720	0.0010001	120.96	120.97	33.60	2482.6	2516.2	0.1213	8.8300	8.9513
9.0	282.15	1.1472	0.0010002	113.43	113.44	37.80	2480.3	2518.1	0.1362	8.7903	8.9265
10.0	283.15	1.2270	0.0010003	106.43	106.43	41.99	2477.9	2519.9	0.1510	8.7510	8.9020
12.0	285.15	1.4014	0.0010004	93.83	93.84	50.34	2473.2	2523.6	0.1805	8.6731	8.8536
14.0	287.15	1.5973	0.0010007	82.90	82.90	58.75	2468.5	2527.2	0.2098	8.5963	8.8060
16.0	289.15	1.8168	0.0010010	73.38	73.38	67.13	2463.8	2530.9	0.2388	8.5205	8.7593
18.0	291.15	2.0624	0.0010013	65.09	65.09	75.50	2459.0	2534.5	0.2677	8.4458	8.7135
20.0	293.15	2.337	0.0010017	57.84	57.84	83.86	2454.3	2538.2	0.2963	8.3721	8.6694
22.0	295.15	2.642	0.0010022	51.49	51.49	92.23	2449.6	2541.8	0.3247	8.2994	8.6241
24.0	297.15	2.982	0.0010026	45.92	45.93	100.59	2444.9	2545.5	0.3530	8.2277	8.5806
26.0	299.15	3.360	0.0010032	41.03	41.03	108.95	2440.2	2549.1	0.3810	8.1569	8.5379
28.0	301.15	3.778	0.0010037	36.73	36.73	117.31	2435.4	2552.7	0.4088	8.0870	8.4959
30.0	303.15	4.241	0.0010043	32.93	32.93	125.66	2430.7	2556.4	0.4365	8.0181	8.4546
32.0	305.15	4.753	0.0010049	29.57	29.57	134.02	2425.9	2560.0	0.4640	7.9500	8.4140
34.0	307.15	5.318	0.0010056	26.60	26.60	142.34	2421.2	2563.6	0.4913	7.8828	8.3740
36.0	309.15	5.940	0.0010063	23.97	23.97	150.74	2416.4	2567.2	0.5184	7.8164	8.3348
38.0	311.15	6.624	0.0010070	21.63	21.63	159.09	2411.7	2570.8	0.5453	7.7509	8.2962
40.0	313.15	7.375	0.0010078	19.545	19.546	167.45	2406.9	2574.4	0.5721	7.6861	8.2583
42.0	315.15	8.198	0.0010086	17.691	17.692	175.81	2402.1	2577.9	0.5987	7.6222	8.2209
44.0	317.15	9.100	0.0010094	16.035	16.036	184.17	2397.3	2581.5	0.6252	7.5590	8.1842
46.0	319.15	10.086	0.0010103	14.556	14.557	192.53	2392.5	2585.1	0.6514	7.4966	8.1481
48.0	321.15	11.162	0.0010112	13.232	13.233	200.89	2387.7	2588.6	0.6776	7.4350	8.1125
50.0	323.15	12.335	0.0010121	12.045	12.046	209.26	2382.9	2592.2	0.7035	7.3741	8.0776
52.0	325.15	13.613	0.0010131	10.979	10.980	217.62	2378.1	2595.7	0.7293	7.3138	8.0432
54.0	327.15	15.002	0.0010140	10.021	10.022	225.99	2373.2	2599.2	0.7550	7.2543	8.0093
56.0	329.15	16.511	0.0010150	9.158	9.159	234.35	2368.4	2602.7	0.7804	7.1955	7.9759
58.0	331.15	18.147	0.0010161	8.380	8.381	242.72	2363.5	2606.2	0.8058	7.1373	7.9431
60.0	333.15	19.920	0.0010171	7.678	7.679	251.09	2358.6	2609.7	0.8310	7.0798	7.9108
62.0	335.15	21.838	0.0010182	7.043	7.044	259.46	2353.7	2613.2	0.8560	7.0230	7.8790
64.0	337.15	23.912	0.0010193	6.468	6.469	267.84	2348.9	2616.6	0.8809	6.9667	7.8477
66.0	339.15	26.150	0.0010205	5.947	5.948	276.21	2343.9	2620.1	0.9057	6.9111	7.8168
68.0	341.15	28.563	0.0010217	5.475	5.476	284.59	2338.9	2623.5	0.9303	6.8561	7.7864
70.0	343.15	31.16	0.0010228	5.045	5.046	292.97	2334.0	2626.9	0.9548	6.8017	7.7565
72.0	345.15	33.96	0.0010241	4.655	4.656	301.36	2329.0	2630.3	0.9792	6.7478	7.7270
74.0	347.15	36.96	0.0010253	4.299	4.300	309.74	2324.0	2633.7	1.0034	6.6945	7.6979
76.0	349.15	40.19	0.0010266	3.975	3.976	318.13	2318.9	2637.1	1.0275	6.6418	7.6693
78.0	351.15	43.65	0.0010279	3.679	3.680	326.52	2313.9	2640.4	1.0514	6.5896	7.6410
80.0	353.15	47.36	0.0010292	3.408	3.409	334.92	2308.9	2643.8	1.0753	6.5380	7.6132
82.0	355.15	51.33	0.0010305	3.161	3.162	343.31	2303.8	2647.1	1.0990	6.4868	7.5858
84.0	357.15	55.57	0.0010319	2.934	2.935	351.71	2298.6	2650.4	1.1225	6.4362	7.5588
86.0	359.15	60.11	0.0010333	2.726	2.727	360.12	2293.5	2653.6	1.1460	6.3861	7.5321
88.0	361.15	64.95	0.0010347	2.535	2.536	368.53	2288.4	2656.9	1.1693	6.3365	7.5058
90.0	363.15	70.11	0.0010361	2.3603	2.3613	376.94	2283.2	2660.1	1.1925	6.2873	7.4799
92.0	365.15	75.61	0.0010376	2.1992	2.2002	385.36	2278.0	2663.4	1.2156	6.2387	7.4543
94.0	367.15	81.46	0.0010391	2.0509	2.0519	393.79	2272.9	2666.6	1.2386	6.1905	7.4291
96.0	369.15	87.69	0.0010406	1.9143	1.9153	402.20	2267.9	2669.7	1.2615	6.1427	7.4042
98.0	371.15	94.30	0.0010421	1.7883	1.7893	410.63	2262.2	2672.9	1.2842	6.0954	7.3796
100.0	373.15	101.33	0.0010437	1.6720	1.6730	419.06	2256.9	2676.0	1.3069	6.0485	7.3554

PROPERTIES OF SATURATED STEAM AND SATURATED WATER (TEMPERATURE)

TABLE 2

Temperature °C <i>t</i>	K <i>T</i>	Press. kPa <i>p</i>	Volume, m ³ /kg			Enthalpy, kJ/kg			Entropy, kJ/kg K		
			Water <i>v_f</i>	Evap. <i>v_{fg}</i>	Steam <i>v_g</i>	Water <i>h_f</i>	Evap. <i>h_{fg}</i>	Steam <i>h_g</i>	Water <i>s_f</i>	Evap. <i>s_{fg}</i>	Steam <i>s_g</i>
100.0	373.15	101.33	0.0010437	1.6720	1.6730	419.06	2256.9	2676.0	1.3069	6.0485	7.3554
105.0	378.15	120.80	0.0010477	1.4182	1.4193	440.17	2243.6	2683.7	1.3630	5.9331	7.2962
110.0	383.15	143.27	0.0010519	1.2089	1.2099	461.32	2230.0	2691.3	1.4189	5.8203	7.2388
115.0	388.15	169.06	0.0010562	1.0352	1.0363	482.90	2216.2	2698.7	1.4733	5.7099	7.1832
120.0	393.15	198.54	0.0010606	0.8905	0.8915	503.72	2202.2	2706.0	1.5276	5.6017	7.1293
125.0	398.15	232.1	0.0010652	0.7692	0.7702	524.99	2188.0	2713.0	1.5813	5.4957	7.0769
130.0	403.15	270.1	0.0010700	0.6671	0.6681	546.31	2173.6	2719.9	1.6344	5.3917	7.0261
135.0	408.15	313.1	0.0010750	0.5807	0.5818	567.68	2158.9	2726.6	1.6869	5.2897	6.9766
140.0	413.15	361.4	0.0010801	0.5074	0.5085	589.10	2144.0	2733.1	1.7390	5.1894	6.9284
145.0	418.15	415.5	0.0010853	0.4449	0.4460	610.59	2128.7	2739.3	1.7906	5.0910	6.8815
150.0	423.15	476.0	0.0010908	0.3914	0.3924	632.15	2113.2	2745.4	1.8416	4.9941	6.8358
155.0	428.15	543.3	0.0010964	0.3453	0.3464	653.77	2097.4	2751.2	1.8923	4.8989	6.7911
160.0	433.15	618.1	0.0011022	0.3057	0.3068	675.47	2081.3	2756.7	1.9425	4.8050	6.7475
165.0	438.15	700.8	0.0011082	0.2713	0.2724	697.25	2064.8	2762.0	1.9923	4.7126	6.7048
170.0	443.15	792.0	0.0011145	0.2414	0.2426	719.12	2047.9	2767.1	2.0416	4.6214	6.6630
175.0	448.15	892.4	0.0011209	0.21542	0.21654	741.07	2030.7	2771.8	2.0906	4.5314	6.6221
180.0	453.15	1002.7	0.0011275	0.19267	0.19380	763.12	2013.2	2776.3	2.1393	4.4426	6.5819
185.0	458.15	1123.3	0.0011344	0.17272	0.17386	785.26	1995.2	2780.4	2.1876	4.3548	6.5424
190.0	463.15	1255.1	0.0011415	0.15517	0.15632	807.52	1976.7	2784.3	2.2356	4.2688	6.5036
195.0	468.15	1398.7	0.0011489	0.13969	0.14084	829.88	1957.9	2787.8	2.2833	4.1821	6.4654
200.0	473.15	1554.9	0.0011565	0.12600	0.12716	852.37	1938.6	2790.9	2.3307	4.0971	6.4278
205.0	478.15	1724.3	0.0011644	0.11386	0.11503	874.99	1918.8	2793.8	2.3778	4.0128	6.3906
210.0	483.15	1907.7	0.0011726	0.10307	0.10424	897.73	1898.5	2796.2	2.4247	3.9293	6.3539
215.0	488.15	2106.0	0.0011811	0.09344	0.09463	920.63	1877.6	2798.3	2.4713	3.8463	6.3176
220.0	493.15	2319.8	0.0011900	0.08485	0.08604	943.67	1856.2	2799.9	2.5178	3.7639	6.2817
225.0	498.15	2550.	0.0011992	0.07715	0.07835	966.88	1834.3	2801.2	2.5641	3.6820	6.2461
230.0	503.15	2798.	0.0012087	0.07024	0.07149	990.27	1811.7	2802.0	2.6102	3.6006	6.2107
235.0	508.15	3063.	0.0012187	0.06403	0.06525	1013.83	1788.5	2802.3	2.6561	3.5194	6.1756
240.0	513.15	3348.	0.0012291	0.05843	0.05965	1037.60	1764.6	2802.2	2.7020	3.4386	6.1406
245.0	518.15	3652.	0.0012399	0.05337	0.05461	1061.58	1740.0	2801.6	2.7478	3.3579	6.1057
250.0	523.15	3978.	0.0012513	0.04879	0.05004	1085.78	1714.7	2800.4	2.7935	3.2773	6.0708
255.0	528.15	4325.	0.0012632	0.04463	0.04590	1110.23	1688.5	2798.9	2.8392	3.1968	6.0359
260.0	533.15	4694.	0.0012756	0.04086	0.04213	1134.94	1661.5	2796.4	2.8848	3.1161	6.0010
265.0	538.15	5088.	0.0012887	0.03742	0.03871	1159.93	1633.5	2793.5	2.9306	3.0353	5.9658
270.0	543.15	5506.	0.0013025	0.03429	0.03559	1185.23	1604.6	2789.9	2.9763	2.9541	5.9304
275.0	548.15	5950.	0.0013170	0.03142	0.03274	1210.86	1574.7	2785.5	3.0222	2.8725	5.8947
280.0	553.15	6420.	0.0013324	0.02879	0.03013	1236.84	1543.6	2780.4	3.0683	2.7903	5.8586
285.0	558.15	6919.	0.0013487	0.02638	0.02773	1263.21	1511.3	2774.5	3.1146	2.7074	5.8220
290.0	563.15	7446.	0.0013659	0.02417	0.02554	1290.01	1477.6	2767.6	3.1611	2.6237	5.7848
295.0	568.15	8004.	0.0013844	0.02213	0.02351	1317.27	1442.6	2759.8	3.2079	2.5389	5.7469
300.0	573.15	8593.	0.0014041	0.020245	0.021649	1345.05	1406.0	2751.0	3.2552	2.4529	5.7081
305.0	578.15	9214.	0.0014252	0.018502	0.019927	1373.40	1367.7	2741.1	3.3029	2.3656	5.6685
310.0	583.15	9870.	0.0014480	0.016886	0.018334	1402.39	1327.6	2730.0	3.3512	2.2766	5.6278
315.0	588.15	10561.	0.0014726	0.015383	0.016856	1432.09	1285.5	2717.6	3.4002	2.1856	5.5858
320.0	593.15	11289.	0.0014995	0.013980	0.015480	1462.60	1241.1	2703.7	3.4500	2.0923	5.5423
325.0	598.15	12056.	0.0015289	0.012666	0.014195	1494.03	1194.0	2688.0	3.5008	1.9961	5.4969
330.0	603.15	12863.	0.0015615	0.011428	0.012989	1526.52	1143.6	2670.2	3.5528	1.8962	5.4490
335.0	608.15	13712.	0.0015978	0.010256	0.011854	1560.25	1089.5	2649.7	3.6063	1.7916	5.3979
340.0	613.15	14605.	0.0016387	0.009142	0.010780	1595.47	1030.7	2626.2	3.6616	1.6811	5.3427
345.0	618.15	15545.	0.0016858	0.008077	0.009763	1632.52	966.4	2598.9	3.7193	1.5636	5.2828
350.0	623.15	16535.	0.0017411	0.007058	0.008799	1671.94	895.7	2567.7	3.7800	1.4376	5.2177
355.0	628.15	17577.	0.0018085	0.006051	0.007859	1716.63	813.8	2530.4	3.8489	1.2953	5.1442
360.0	633.15	18675.	0.0018959	0.005044	0.006940	1764.17	721.3	2485.4	3.9210	1.1390	5.0600
365.0	638.15	19833.	0.0020160	0.003996	0.006012	1817.96	610.0	2428.0	4.0021	0.9558	4.9579
370.0	643.15	21054.	0.0022136	0.002759	0.004973	1890.21	452.6	2342.8	4.1108	0.7036	4.8144
371.0	644.15	21306.	0.0022778	0.002446	0.004723	1910.50	407.4	2317.9	4.1414	0.6324	4.7738
372.0	645.15	21562.	0.0023636	0.002075	0.004439	1935.57	351.4	2287.0	4.1794	0.5446	4.7240
373.0	646.15	21820.	0.0024963	0.001588	0.004084	1970.50	273.5	2244.0	4.2326	0.4233	4.6559
374.0	647.15	22081.	0.0028427	0.000623	0.003466	2046.72	109.5	2156.2	4.3493	0.1692	4.5185
374.15	647.30	22120.	0.00317	0.0	0.00317	2107.37	0.0	2107.4	4.4429	0.0	4.4429

PROPERTIES OF SATURATED STEAM AND SATURATED WATER (PRESSURE)

TABLE 2

Press. kPa p	Temp. °C t	Volume, m ³ /kg			Enthalpy, kJ/kg			Entropy, kJ/kg K			Energy, kJ/kg	
		Water	Evap.	Steam	Water	Evap.	Steam	Water	Evap.	Steam	Water	Steam
		v_f	v_{fg}	v_g	h_f	h_{fg}	h_g	s_f	s_{fg}	s_g	u_f	u_g
1.0	6.983	0.0010001	129.21	129.21	29.34	2485.0	2514.4	0.1060	8.8776	8.9767	29.33	2385.2
1.1	8.380	0.0010001	118.04	118.04	35.20	2481.7	2516.9	0.1269	8.8149	8.9418	35.20	2387.1
1.2	9.668	0.0010002	108.70	108.70	40.60	2478.7	2519.3	0.1461	8.7640	8.9101	40.60	2388.9
1.3	10.866	0.0010003	100.76	100.76	45.62	2475.9	2521.5	0.1638	8.7171	8.8809	45.62	2390.5
1.4	11.985	0.0010004	93.92	93.92	50.31	2473.2	2523.5	0.1803	8.6737	8.8539	50.31	2392.0
1.5	13.036	0.0010006	87.98	87.98	54.71	2470.7	2525.5	0.1957	8.6332	8.8288	54.71	2393.5
1.6	14.026	0.0010007	82.76	82.77	58.86	2468.4	2527.3	0.2101	8.5952	8.8054	58.86	2394.8
1.8	15.855	0.0010010	74.03	74.03	66.52	2464.1	2530.6	0.2367	8.5260	8.7627	66.52	2397.4
2.0	17.513	0.0010012	67.01	67.01	73.46	2460.2	2533.6	0.2607	8.4639	8.7246	73.46	2399.6
2.2	19.031	0.0010015	61.23	61.23	79.81	2456.6	2536.4	0.2825	8.4077	8.6901	79.81	2401.7
2.4	20.433	0.0010019	56.39	56.39	85.67	2453.3	2539.0	0.3025	8.3563	8.6587	85.67	2403.6
2.6	21.737	0.0010021	52.28	52.28	91.12	2450.2	2541.3	0.3210	8.3089	8.6299	91.12	2405.4
2.8	22.955	0.0010024	48.74	48.74	96.22	2447.3	2543.6	0.3382	8.2650	8.6033	96.21	2407.1
3.0	24.100	0.0010027	45.67	45.67	101.00	2444.6	2545.6	0.3544	8.2241	8.5785	101.00	2408.6
3.5	26.694	0.0010033	39.48	39.48	111.85	2438.5	2550.4	0.3907	8.1325	8.5232	111.84	2412.2
4.0	28.983	0.0010040	34.80	34.80	121.41	2433.1	2554.5	0.4225	8.0530	8.4755	121.41	2415.3
4.5	31.035	0.0010046	31.14	31.14	129.99	2428.2	2558.2	0.4507	7.9827	8.4335	129.98	2418.1
5.0	32.898	0.0010052	28.19	28.19	137.77	2423.8	2561.6	0.4763	7.9197	8.3960	137.77	2420.6
5.5	34.605	0.0010058	25.77	25.77	144.91	2419.8	2564.7	0.4995	7.8626	8.3621	144.90	2422.9
6.0	36.183	0.0010064	23.74	23.74	151.50	2416.0	2567.5	0.5209	7.8104	8.3312	151.50	2425.1
6.5	37.651	0.0010069	22.015	22.016	157.64	2412.5	2570.2	0.5407	7.7622	8.3029	157.63	2427.0
7.0	39.025	0.0010074	20.530	20.531	163.38	2409.2	2572.6	0.5591	7.7176	8.2767	163.37	2428.9
7.5	40.316	0.0010079	19.238	19.239	168.77	2406.2	2574.9	0.5763	7.6760	8.2523	168.76	2430.6
8.0	41.534	0.0010084	18.104	18.105	173.86	2403.2	2577.1	0.5925	7.6370	8.2296	173.86	2432.3
9.0	43.787	0.0010094	16.203	16.204	183.28	2397.9	2581.1	0.6224	7.5657	8.1881	183.27	2435.3
10.	45.833	0.0010102	14.674	14.675	191.83	2392.9	2584.8	0.6493	7.5018	8.1511	191.82	2438.0
11.	47.710	0.0010111	13.415	13.416	199.68	2388.4	2588.1	0.6738	7.4439	8.1177	199.67	2440.5
12.	49.446	0.0010119	12.361	12.362	206.94	2384.3	2591.2	0.6963	7.3909	8.0872	206.93	2442.8
13.	51.062	0.0010126	11.465	11.466	213.70	2380.3	2594.0	0.7172	7.3420	8.0592	213.68	2445.0
14.	52.574	0.0010133	10.693	10.694	220.02	2376.7	2596.7	0.7367	7.2967	8.0334	220.01	2447.0
15.	53.997	0.0010140	10.022	10.023	225.97	2373.2	2599.2	0.7549	7.2544	8.0093	225.96	2448.9
16.	55.341	0.0010147	9.432	9.433	231.59	2370.0	2601.6	0.7721	7.2148	7.9869	231.58	2450.6
18.	57.826	0.0010160	8.444	8.445	241.99	2363.9	2605.9	0.8036	7.1424	7.9460	241.98	2453.9
20.	60.086	0.0010172	7.649	7.650	251.45	2358.4	2609.9	0.8321	7.0774	7.9094	251.43	2456.9
22.	62.162	0.0010183	6.994	6.995	260.14	2353.3	2613.5	0.8581	7.0184	7.8764	260.12	2459.6
24.	64.082	0.0010194	6.446	6.447	268.18	2348.6	2616.8	0.8820	6.9644	7.8464	268.16	2462.1
26.	65.871	0.0010204	5.979	5.980	275.67	2344.2	2619.9	0.9041	6.9147	7.8188	275.65	2464.4
28.	67.547	0.0010214	5.578	5.579	282.69	2340.0	2622.7	0.9248	6.8685	7.7933	282.66	2466.5
30.	69.124	0.0010223	5.228	5.229	289.30	2336.1	2625.4	0.9441	6.8254	7.7695	289.27	2468.6
35.	72.709	0.0010245	4.525	4.526	304.33	2327.2	2631.5	0.9878	6.7268	7.7166	304.29	2473.1
40.	75.886	0.0010265	3.992	3.993	317.65	2319.2	2636.9	1.0261	6.6448	7.6709	317.61	2477.1
45.	78.743	0.0010284	3.575	3.576	329.64	2312.0	2641.7	1.0603	6.5704	7.6307	329.59	2480.7
50.	81.345	0.0010301	3.239	3.240	340.56	2305.4	2646.0	1.0912	6.5035	7.5947	340.51	2484.0
55.	83.737	0.0010317	2.963	2.964	350.61	2299.3	2649.9	1.1194	6.4428	7.5623	350.56	2486.9
60.	85.954	0.0010333	2.731	2.732	359.93	2293.6	2653.8	1.1454	6.3873	7.5327	359.86	2489.7
65.	88.021	0.0010347	2.5335	2.5346	368.62	2288.3	2656.9	1.1696	6.3360	7.5055	368.55	2492.2
70.	89.959	0.0010361	2.3637	2.3647	376.77	2283.3	2660.1	1.1921	6.2883	7.4804	376.70	2494.5
75.	91.785	0.0010375	2.2158	2.2169	384.45	2278.6	2663.0	1.2131	6.2439	7.4570	384.37	2496.7
80.	93.512	0.0010387	2.0859	2.0870	391.72	2274.1	2665.8	1.2330	6.2022	7.4352	391.64	2498.8
90.	96.713	0.0010412	1.8682	1.8692	405.21	2265.8	2670.9	1.2696	6.1258	7.3954	405.11	2502.6
100.	99.632	0.0010434	1.6927	1.6937	417.51	2257.9	2675.4	1.3027	6.0571	7.3598	417.41	2506.1
110.	102.317	0.0010455	1.5482	1.5492	428.84	2250.8	2679.6	1.3330	5.9947	7.3277	428.73	2509.2
120.	104.808	0.0010476	1.4271	1.4281	439.36	2244.1	2683.4	1.3609	5.9375	7.2984	439.24	2512.1
130.	107.133	0.0010495	1.3240	1.3251	449.19	2237.8	2687.0	1.3868	5.8847	7.2715	449.05	2514.7
140.	109.315	0.0010513	1.2353	1.2363	458.42	2231.9	2690.3	1.4109	5.8356	7.2465	458.27	2517.2
150.	111.37	0.0010530	1.1580	1.1590	467.13	2226.2	2693.4	1.4336	5.7898	7.2234	466.97	2519.5
160.	113.32	0.0010547	1.0901	1.0911	475.38	2220.9	2696.2	1.4550	5.7447	7.2017	475.21	2521.7
180.	116.93	0.0010579	0.9762	0.9772	490.70	2210.8	2701.5	1.4944	5.6678	7.1622	490.51	2525.6
200.	120.23	0.0010608	0.8844	0.8854	504.70	2201.6	2706.3	1.5301	5.5967	7.1268	504.49	2529.2
220.	123.27	0.0010636	0.8088	0.8098	517.62	2193.0	2710.6	1.5627	5.5321	7.0949	517.39	2532.4
240.	126.09	0.0010663	0.7454	0.7465	529.63	2184.9	2714.5	1.5929	5.4728	7.0657	529.38	2535.4

PROPERTIES OF SATURATED STEAM AND SATURATED WATER (PRESSURE)

TABLE 2

Press. kPa <i>p</i>	Temp. °C <i>t</i>	Volume, m ³ /kg			Enthalpy, kJ/kg			Entropy, kJ/kg K			Energy, kJ/kg	
		Water <i>v_f</i>	Evap. <i>v_{fg}</i>	Steam <i>v_g</i>	Water <i>h_f</i>	Evap. <i>h_{fg}</i>	Steam <i>h_g</i>	Water <i>s_f</i>	Evap. <i>s_{fg}</i>	Steam <i>s_g</i>	Water <i>u_f</i>	Steam <i>u_g</i>
240.	126.09	0.0010663	0.7454	0.7445	529.6	2184.9	2714.5	1.5929	5.4728	7.0657	529.38	2535.4
260.	128.73	0.0010688	0.6914	0.6925	540.9	2177.3	2718.2	1.6209	5.4180	7.0389	540.60	2538.1
280.	131.20	0.0010712	0.6450	0.6460	551.4	2170.1	2721.5	1.6471	5.3670	7.0140	551.14	2540.6
300.	133.54	0.0010735	0.6045	0.6056	561.4	2163.2	2724.7	1.6716	5.3193	6.9919	561.11	2543.0
350.	138.87	0.0010789	0.5229	0.5240	584.3	2147.4	2731.6	1.7273	5.2119	6.9392	583.89	2548.2
400.	143.62	0.0010839	0.4611	0.4622	604.7	2133.0	2737.6	1.7764	5.1179	6.8943	604.24	2552.7
450.	147.92	0.0010885	0.4127	0.4138	623.2	2119.7	2742.9	1.8204	5.0343	6.8547	622.67	2556.7
500.	151.84	0.0010928	0.3736	0.3747	640.1	2107.4	2747.5	1.8604	4.9588	6.8192	639.57	2560.2
550.	155.47	0.0010969	0.3414	0.3425	655.8	2095.9	2751.7	1.8970	4.8900	6.7870	655.20	2563.3
600.	158.84	0.0011009	0.3144	0.3155	670.4	2085.0	2755.5	1.9308	4.8267	6.7575	669.76	2566.2
650.	161.99	0.0011046	0.29138	0.29249	684.1	2074.7	2758.9	1.9623	4.7681	6.7304	683.42	2568.7
700.	164.96	0.0011082	0.27197	0.27268	697.1	2064.9	2762.0	1.9918	4.7134	6.7052	696.29	2571.1
750.	167.76	0.0011116	0.25431	0.25543	709.3	2055.5	2764.8	2.0195	4.6621	6.6817	708.47	2573.3
800.	170.41	0.0011150	0.23914	0.24026	720.9	2046.5	2767.5	2.0457	4.6139	6.6596	720.04	2575.3
900.	175.38	0.0011213	0.21369	0.21481	742.6	2029.5	2772.1	2.0941	4.5250	6.6192	741.63	2578.8
1000.	179.68	0.0011274	0.19317	0.19429	762.6	2013.6	2776.2	2.1382	4.4446	6.5828	761.48	2581.9
1100.	184.07	0.0011331	0.17629	0.17738	781.1	1998.5	2779.7	2.1786	4.3711	6.5497	779.88	2584.5
1200.	187.96	0.0011386	0.16288	0.16320	798.4	1984.3	2782.7	2.2161	4.3033	6.5194	797.86	2586.9
1300.	191.61	0.0011438	0.14998	0.15113	814.7	1970.7	2785.4	2.2510	4.2403	6.4913	813.21	2589.0
1400.	195.04	0.0011489	0.13987	0.14072	830.1	1957.7	2787.8	2.2837	4.1814	6.4651	828.47	2590.8
1500.	198.29	0.0011539	0.13050	0.13166	844.7	1945.2	2789.9	2.3145	4.1261	6.4406	842.93	2592.4
1600.	201.37	0.0011586	0.12253	0.12369	858.6	1933.2	2791.7	2.3436	4.0739	6.4175	856.71	2593.8
1800.	207.11	0.0011678	0.10915	0.11032	884.6	1918.3	2794.8	2.3976	3.9775	6.3751	882.47	2596.3
2000.	212.37	0.0011766	0.09836	0.09954	908.6	1898.6	2797.2	2.4469	3.8898	6.3367	906.24	2598.2
2200.	217.24	0.0011850	0.08947	0.09065	931.0	1886.1	2799.1	2.4922	3.8093	6.3015	928.33	2599.6
2400.	221.78	0.0011932	0.08201	0.08320	951.9	1884.5	2800.4	2.5343	3.7347	6.2690	949.07	2600.7
2600.	226.04	0.0012011	0.07565	0.07686	971.7	1829.6	2801.4	2.5736	3.6651	6.2387	968.60	2601.5
2800.	230.05	0.0012088	0.07018	0.07139	990.5	1811.5	2802.0	2.6106	3.5998	6.2104	987.10	2602.1
3000.	233.84	0.0012163	0.06541	0.06663	1008.4	1793.9	2802.3	2.6455	3.5382	6.1837	1004.70	2602.4
3500.	242.54	0.0012345	0.05579	0.05703	1049.8	1752.2	2802.0	2.7253	3.3976	6.1228	1045.46	2602.4
4000.	250.33	0.0012521	0.04850	0.04975	1087.4	1712.9	2800.3	2.7965	3.2720	6.0685	1082.4	2601.3
4500.	257.41	0.0012691	0.04277	0.04404	1122.1	1675.6	2797.7	2.8612	3.1579	6.0191	1116.4	2599.5
5000.	263.91	0.0012858	0.03814	0.03943	1154.5	1639.7	2794.2	2.9206	3.0529	5.9735	1148.0	2597.0
5500.	269.93	0.0013023	0.03433	0.03563	1184.9	1605.0	2789.9	2.9757	2.9552	5.9309	1177.7	2594.0
6000.	275.55	0.0013187	0.03112	0.03244	1213.7	1571.3	2785.0	3.0273	2.8635	5.8908	1205.8	2590.4
6500.	280.82	0.0013350	0.028384	0.029719	1241.1	1538.4	2779.5	3.0759	2.7768	5.8527	1232.5	2586.3
7000.	285.79	0.0013513	0.026022	0.027373	1267.4	1506.0	2773.5	3.1219	2.6943	5.8162	1258.0	2581.8
7500.	290.50	0.0013677	0.023959	0.025327	1292.7	1474.2	2766.9	3.1657	2.6193	5.7811	1282.4	2577.0
8000.	294.97	0.0013842	0.022141	0.023525	1317.1	1442.8	2759.9	3.2076	2.5595	5.7471	1306.0	2571.7
9000.	303.31	0.0014179	0.019078	0.020495	1363.7	1380.9	2744.6	3.2867	2.3993	5.6820	1351.0	2560.1
10000.	310.96	0.0014526	0.016589	0.018041	1408.0	1319.7	2727.7	3.3605	2.2593	5.6198	1393.5	2547.3
11000.	318.05	0.0014887	0.014517	0.016006	1450.6	1258.7	2709.3	3.4304	2.1291	5.5595	1434.2	2533.2
12000.	324.63	0.0015268	0.012756	0.014263	1491.8	1197.4	2689.2	3.4972	2.0030	5.5002	1473.4	2517.8
13000.	330.83	0.0015672	0.011230	0.012797	1532.0	1135.0	2667.0	3.5616	1.8792	5.4408	1511.6	2500.6
14000.	336.64	0.0016106	0.009884	0.011495	1571.6	1070.7	2642.4	3.6242	1.7560	5.3803	1549.1	2481.4
15000.	342.13	0.0016579	0.008682	0.010340	1611.0	1004.0	2615.0	3.6859	1.6320	5.3178	1586.1	2459.9
16000.	347.33	0.0017103	0.007597	0.009308	1650.5	934.3	2584.9	3.7471	1.5060	5.2531	1623.2	2436.0
17000.	352.26	0.0017696	0.006601	0.008371	1691.7	859.9	2551.6	3.8107	1.3748	5.1855	1661.6	2409.3
18000.	356.96	0.0018399	0.005658	0.007498	1734.8	779.1	2513.9	3.8765	1.2342	5.1128	1701.7	2378.9
19000.	361.43	0.0019260	0.004751	0.006678	1778.7	692.0	2470.6	3.9429	1.0903	5.0332	1742.1	2343.8
20000.	365.70	0.0020370	0.003840	0.005877	1826.5	591.9	2418.4	4.0149	0.9243	4.9412	1785.7	2300.8
21000.	369.78	0.0022015	0.002822	0.005023	1886.3	461.3	2347.6	4.1048	0.7175	4.8223	1840.0	2242.1
22000.	373.69	0.0026714	0.001056	0.003728	2011.1	184.5	2195.6	4.2947	0.2852	4.5799	1952.4	2113.6
22120.	374.15	0.00317	0.0	0.00317	2107.4	0.0	2107.4	4.4429	0.0	4.4429	2037.3	2037.3

**PROPERTIES OF SUPERHEATED STEAM AND COMPRESSED WATER
(TEMPERATURE AND PRESSURE)**

TABLE 2
Temperature, t , °C

Press. p , kPa (t_s)		0.	20.	40.	60.	80.	100.	120.	140.	160.
1.0 h (6.983) s	v	0.0010002	135.23	144.47	153.71	162.95	172.19	181.42	190.66	199.89
	s	-0.0002	2538.6	2575.9	2613.3	2650.9	2688.6	2726.5	2764.6	2802.9
1.5 h (13.04) s	v	0.0010002	90.131	96.298	102.46	108.62	114.78	120.94	127.10	133.25
	s	-0.0002	2538.4	2575.8	2613.2	2650.8	2688.6	2726.5	2764.6	2802.9
2.0 h (17.51) s	v	0.0010002	67.582	72.211	76.837	81.459	86.080	90.700	95.319	99.936
	s	-0.0002	2538.3	2575.6	2613.1	2650.7	2688.5	2726.4	2764.5	2802.8
3.0 h (24.10) s	v	0.0010002	0.0010017	48.124	51.211	54.296	57.378	60.460	63.540	66.619
	s	-0.0002	83.9	2575.4	2612.9	2650.6	2688.4	2726.3	2764.5	2802.8
4.0 h (28.98) s	v	0.0010002	0.0010017	36.081	38.398	40.714	43.027	45.339	47.650	49.961
	s	-0.0002	83.9	2575.2	2612.7	2650.4	2688.3	2726.2	2764.4	2802.7
5.0 h (32.90) s	v	0.0010002	0.0010017	28.854	30.711	32.565	34.417	36.267	38.117	39.966
	s	-0.0002	83.9	2574.9	2612.6	2650.3	2688.1	2726.1	2764.3	2802.6
6.0 h (36.18) s	v	0.0010002	0.0010017	24.037	25.586	27.132	28.676	30.219	31.761	33.302
	s	-0.0002	83.9	2574.7	2612.4	2650.1	2688.0	2726.0	2764.2	2802.6
8.0 h (41.53) s	v	0.0010002	0.0010017	0.0010078	19.179	20.341	21.501	22.659	23.816	24.973
	s	-0.0002	83.9	167.5	2612.0	2649.8	2687.8	2725.8	2764.1	2802.4
10.0 h (45.83) s	v	0.0010002	0.0010017	0.0010078	15.336	16.266	17.195	18.123	19.050	19.975
	s	-0.0002	83.9	167.5	2611.6	2649.5	2687.5	2725.6	2763.9	2802.3
15.0 h (54.00) s	v	0.0010002	0.0010017	0.0010078	10.210	10.834	11.455	12.075	12.694	13.312
	s	-0.0002	83.9	167.5	2610.6	2648.8	2686.9	2725.1	2763.5	2802.0
20.0 h (60.09) s	v	0.0010002	0.0010017	0.0010078	0.0010171	8.1172	8.5847	9.0508	9.516	9.980
	s	-0.0002	83.9	167.5	251.1	2648.0	2686.3	2724.6	2763.1	2801.6
30.0 h (69.12) s	v	0.0010002	0.0010017	0.0010078	0.0010171	5.4007	5.7144	6.0267	6.3379	6.6483
	s	-0.0002	83.9	167.5	251.1	2646.5	2685.1	2723.6	2762.3	2801.0
40.0 h (75.89) s	v	0.0010002	0.0010017	0.0010078	0.0010171	4.0424	4.2792	4.5146	4.7489	4.9825
	s	-0.0002	83.9	167.5	251.1	2644.9	2683.8	2722.6	2761.4	2800.3
50.0 h (81.35) s	v	0.0010002	0.0010017	0.0010078	0.0010171	0.0010292	3.4181	3.6074	3.7955	3.9829
	s	-0.0002	83.9	167.5	251.1	334.9	2682.6	2721.6	2760.6	2799.6
60.0 h (85.95) s	v	0.0010002	0.0010017	0.0010078	0.0010171	0.0010292	2.8440	3.0025	3.1599	3.3165
	s	-0.0001	83.9	167.5	251.1	334.9	2681.3	2720.6	2759.8	2798.9
80.0 h (93.51) s	v	0.0010002	0.0010017	0.0010078	0.0010171	0.0010292	2.1262	2.2464	2.3654	2.4836
	s	-0.0001	83.9	167.5	251.1	334.9	2678.8	2718.6	2758.1	2797.5
100.0 h (99.63) s	v	0.0010002	0.0010017	0.0010078	0.0010171	0.0010292	1.6955	1.7927	1.8886	1.9838
	s	-0.0001	84.0	167.5	251.2	335.0	2676.2	2716.5	2756.4	2796.2
150.0 h (111.4) s	v	0.0010001	0.0010017	0.0010077	0.0010171	0.0010291	0.0010437	1.1876	1.2529	1.3173
	s	-0.0001	84.0	167.6	251.2	335.0	419.1	2711.2	2752.2	2792.7
200.0 h (120.2) s	v	0.0010001	0.0010016	0.0010077	0.0010171	0.0010291	0.0010437	0.0010606	0.9349	0.9840
	s	-0.0001	84.0	167.6	251.2	335.0	419.1	503.7	2747.8	2789.1
300.0 h (133.5) s	v	0.0010001	0.0010016	0.0010077	0.0010170	0.0010291	0.0010436	0.0010606	0.6167	0.6506
	s	-0.0001	84.1	167.7	251.3	335.1	419.2	503.8	2738.8	2781.8
400.0 h (143.6) s	v	0.0010000	0.0010015	0.0010076	0.0010170	0.0010290	0.0010436	0.0010605	0.0010800	0.4837
	s	-0.0001	84.2	167.8	251.4	335.2	419.3	503.9	589.1	2774.2

**PROPERTIES OF SUPERHEATED STEAM AND COMPRESSED WATER
(TEMPERATURE AND PRESSURE)**

TABLE 2
Temperature, t , °C

									Press. p , kPa
180.	200.	220.	240.	260.	280.	300.	320.	340.	
209.12 2841.4 9.8843	218.35 2880.1 9.9679	227.58 2919.0 10.0484	236.82 2958.1 10.1262	246.05 2997.4 10.2014	255.28 3037.0 10.2743	264.51 3076.8 10.3450	273.74 3116.9 10.4137	282.97 v 3157.2 h 10.4805 s	1.0
139.41 2841.4 9.6972	145.56 2880.0 9.7807	151.72 2918.9 9.8612	157.87 2958.1 9.9390	164.03 2997.4 10.0142	170.18 3037.0 10.0871	176.34 3076.8 10.1578	182.49 3116.9 10.2266	188.64 v 3157.2 h 10.2934 s	1.5
104.55 2841.3 9.5643	109.17 2880.0 9.6479	113.79 2918.9 9.7284	118.40 2958.0 9.8062	123.02 2997.4 9.8814	127.64 3037.0 9.9543	132.25 3076.8 10.0251	136.87 3116.9 10.0938	141.48 v 3157.2 h 10.1606 s	2.0
69.698 2841.3 9.3771	72.777 2880.0 9.4607	75.855 2918.9 9.5412	78.933 2958.0 9.6190	82.010 2997.4 9.6943	85.088 3037.0 9.7672	88.165 3076.8 9.8379	91.242 3116.9 9.9066	94.320 v 3157.2 h 9.9735 s	3.0
52.270 2841.2 9.2443	54.580 2879.9 9.3279	56.889 2918.8 9.4084	59.197 2958.0 9.4862	61.506 2997.3 9.5615	63.814 3036.9 9.6344	66.122 3076.8 9.7051	68.430 3116.8 9.7738	70.738 v 3157.2 h 9.8407 s	4.0
41.814 2841.2 9.1412	43.661 2879.9 9.2248	45.509 2918.8 9.3054	47.356 2957.9 9.3832	49.203 2997.3 9.4584	51.050 3036.9 9.5313	52.897 3076.7 9.6021	54.743 3116.8 9.6708	56.590 v 3157.1 h 9.7377 s	5.0
34.843 2841.1 9.0569	36.383 2879.8 9.1406	37.922 2918.8 9.2212	39.462 2957.9 9.2990	41.001 2997.3 9.3742	42.540 3036.9 9.4472	44.079 3076.7 9.5179	45.618 3116.8 9.5866	47.157 v 3157.1 h 9.6535 s	6.0
26.129 2841.0 8.9240	27.284 2879.7 9.0077	28.439 2918.7 9.0883	29.594 2957.8 9.1661	30.749 2997.2 9.2414	31.903 3036.8 9.3143	33.058 3076.7 9.3851	34.212 3116.8 9.4538	35.367 v 3157.1 h 9.5207 s	8.0
20.900 2840.9 8.8208	21.825 2879.6 8.9045	22.750 2918.6 8.9852	23.674 2957.8 9.0630	24.598 2997.2 9.1383	25.521 3036.8 9.2113	26.445 3076.6 9.2820	27.369 3116.7 9.3508	28.292 v 3157.0 h 9.4177 s	10.0
13.929 2840.6 8.6332	14.546 2879.4 8.7170	15.163 2918.4 8.7977	15.780 2957.6 8.8757	16.396 2997.0 8.9510	17.012 3036.6 9.0240	17.628 3076.5 9.0948	18.244 3116.6 9.1635	18.860 v 3157.0 h 9.2304 s	15.0
10.444 2840.3 8.5000	10.907 2879.2 8.5839	11.370 2918.2 8.6647	11.832 2957.4 8.7426	12.295 2996.9 8.8180	12.757 3036.5 8.8910	13.219 3076.4 8.9618	13.681 3116.5 9.0306	14.143 v 3156.9 h 9.0975 s	20.0
6.9582 2839.8 8.3119	7.2675 2878.7 8.3960	7.5766 2917.8 8.4769	7.8854 2957.1 8.5550	8.1940 2996.6 8.6305	8.5024 3036.2 8.7035	8.8108 3076.1 8.7744	9.1190 3116.3 8.8432	9.4272 v 3156.7 h 8.9102 s	30.0
5.2154 2839.2 8.1782	5.4478 2878.2 8.2625	5.6800 2917.4 8.3435	5.9118 2956.7 8.4217	6.1435 2996.3 8.4973	6.3751 3036.0 8.5704	6.6065 3075.9 8.6413	6.8378 3116.1 8.7102	7.0690 v 3156.5 h 8.7772 s	40.0
4.1697 2838.6 8.0742	4.3560 2877.7 8.1587	4.5420 2917.0 8.2399	4.7277 2956.4 8.3182	4.9133 2995.9 8.3939	5.0986 3035.7 8.4671	5.2839 3075.7 8.5380	5.4691 3115.9 8.6070	5.6542 v 3156.3 h 8.6740 s	50.0
3.4726 2838.1 7.9891	3.6281 2877.3 8.0738	3.7833 2916.6 8.1552	3.9383 2956.0 8.2336	4.0931 2995.6 8.3093	4.2477 3035.4 8.3826	4.4022 3075.4 8.4536	4.5566 3115.6 8.5226	4.7109 v 3156.1 h 8.5896 s	60.0
2.6011 2836.9 7.8544	2.7183 2876.3 7.9395	2.8350 2915.8 8.0212	2.9515 2955.3 8.0998	3.0678 2995.0 8.1757	3.1840 3034.9 8.2491	3.3000 3075.0 8.3202	3.4160 3115.2 8.3893	3.5319 v 3155.7 h 8.4564 s	80.0
2.0783 2835.8 7.7495	2.1723 2875.4 7.8349	2.2660 2915.0 7.9169	2.3595 2954.6 7.9958	2.4527 2994.4 8.0719	2.5458 3034.4 8.1454	2.6387 3074.5 8.2166	2.7316 3114.8 8.2857	2.8244 v 3155.3 h 8.3529 s	100.0
1.3811 2832.9 7.5574	1.4444 2872.9 7.6439	1.5073 2912.9 7.7266	1.5700 2952.9 7.8061	1.6325 2992.9 7.8826	1.6948 3033.0 7.9565	1.7570 3073.3 8.0280	1.8191 3113.7 8.0973	1.8812 v 3154.3 h 8.1646 s	150.0
1.0325 2830.0 7.4196	1.0804 2870.5 7.5072	1.1280 2910.8 7.5907	1.1753 2951.1 7.6707	1.2224 2991.4 7.7477	1.2693 3031.7 7.8219	1.3162 3072.1 7.8937	1.3629 3112.6 7.9632	1.4095 v 3153.3 h 8.0307 s	200.0
0.6837 2824.0 7.2222	0.7164 2865.5 7.3119	0.7486 2908.6 7.3971	0.7805 2947.5 7.4783	0.8123 2988.2 7.5562	0.8438 3028.9 7.6311	0.8753 3069.7 7.7034	0.9066 3110.5 7.7734	0.9379 v 3151.4 h 7.8412 s	300.0
0.5093 2817.8 7.0788	0.5343 2860.4 7.1708	0.5589 2902.3 7.2576	0.5831 2943.9 7.3402	0.6072 2985.1 7.4190	0.6311 3026.2 7.4947	0.6549 3067.2 7.5675	0.6785 3108.3 7.6379	0.7021 v 3149.4 h 7.7061 s	400.0

**PROPERTIES OF SUPERHEATED STEAM AND COMPRESSED WATER
(TEMPERATURE AND PRESSURE)**

TABLE 2
Temperature, *t*, °C

Press. <i>p</i> , kPa (<i>t_g</i>)	360.	380.	400.	420.	440.	460.	480.	500.	520.
v	292.20	301.43	310.66	319.89	329.12	338.35	347.58	356.81	366.04
1.0 h	3197.8	3238.6	3279.7	3321.1	3362.7	3404.6	3446.8	3489.2	3531.9
(6.983) s	10.5457	10.6091	10.6711	10.7317	10.7909	10.8488	10.9056	10.9612	11.0157
v	194.80	200.95	207.11	213.26	219.41	225.57	231.72	237.87	244.03
1.5 h	3197.8	3238.6	3279.7	3321.1	3362.7	3404.6	3446.8	3489.2	3531.9
(13.04) s	10.3585	10.4220	10.4840	10.5445	10.6037	10.6617	10.7184	10.7741	10.8286
v	146.10	150.71	155.33	159.94	164.56	169.17	173.79	178.41	183.02
2.0 h	3197.8	3238.6	3279.7	3321.1	3362.7	3404.6	3446.8	3489.2	3531.9
(17.51) s	10.2257	10.2892	10.3512	10.4118	10.4710	10.5289	10.5857	10.6413	10.6958
v	97.397	100.47	103.55	106.63	109.71	112.78	115.86	118.94	122.01
3.0 h	3197.8	3238.6	3279.7	3321.1	3362.7	3404.6	3446.8	3489.2	3531.9
(24.10) s	10.0386	10.1021	10.1641	10.2246	10.2838	10.3418	10.3985	10.4541	10.5087
v	73.046	75.354	77.662	79.970	82.278	84.586	86.893	89.201	91.509
4.0 h	3197.7	3238.6	3279.7	3321.0	3362.7	3404.6	3446.7	3489.2	3531.9
(28.98) s	9.9058	9.9693	10.0313	10.0918	10.1510	10.2090	10.2657	10.3214	10.3759
v	58.436	60.283	62.129	63.975	65.822	67.668	69.514	71.360	73.207
5.0 h	3197.7	3238.6	3279.7	3321.0	3362.7	3404.6	3446.7	3489.2	3531.9
(32.90) s	9.8028	9.8663	9.9283	9.9888	10.0480	10.1060	10.1627	10.2184	10.2729
v	48.696	50.235	51.773	53.312	54.851	56.389	57.928	59.467	61.005
6.0 h	3197.7	3238.5	3279.6	3321.0	3362.6	3404.5	3446.7	3489.2	3531.9
(36.18) s	9.7186	9.7821	9.8441	9.9047	9.9639	10.0218	10.0786	10.1342	10.1888
v	36.521	37.675	38.829	39.983	41.137	42.291	43.445	44.599	45.753
8.0 h	3197.7	3238.5	3279.6	3321.0	3362.6	3404.5	3446.7	3489.1	3531.9
(41.53) s	9.5858	9.6493	9.7113	9.7719	9.8311	9.8890	9.9458	10.0014	10.0560
v	29.216	30.139	31.062	31.986	32.909	33.832	34.756	35.679	36.602
10.0 h	3197.6	3238.5	3279.6	3321.0	3362.6	3404.5	3446.7	3489.1	3531.9
(45.83) s	9.4828	9.5463	9.6083	9.6689	9.7281	9.7860	9.8428	9.8984	9.9530
v	19.475	20.091	20.707	21.323	21.938	22.554	23.169	23.785	24.400
15.0 h	3197.5	3238.4	3279.5	3320.9	3362.5	3404.4	3446.6	3489.1	3531.8
(54.00) s	9.2956	9.3591	9.4211	9.4817	9.5409	9.5988	9.6556	9.7112	9.7658
v	14.605	15.067	15.529	15.991	16.453	16.914	17.376	17.838	18.300
20.0 h	3197.5	3238.3	3279.4	3320.8	3362.5	3404.4	3446.6	3489.0	3531.8
(60.09) s	9.1627	9.2262	9.2882	9.3488	9.4081	9.4660	9.5228	9.5784	9.6330
v	9.7353	10.043	10.351	10.659	10.967	11.275	11.583	11.891	12.199
30.0 h	3197.3	3238.2	3279.3	3320.7	3362.3	3404.2	3446.4	3489.0	3531.6
(69.12) s	8.9754	9.0389	9.1010	9.1615	9.2208	9.2788	9.3355	9.3912	9.4458
v	7.3002	7.5314	7.7625	7.9935	8.2246	8.4556	8.6866	8.9176	9.1485
40.0 h	3197.1	3238.0	3279.1	3320.5	3362.2	3404.1	3446.3	3489.8	3531.5
(75.89) s	8.8424	8.9060	8.9680	9.0286	9.0879	9.1459	9.2027	9.2583	9.3129
v	5.8392	6.0242	6.2091	6.3941	6.5790	6.7638	6.9487	7.1335	7.3183
50.0 h	3196.9	3237.8	3279.0	3320.4	3362.1	3404.0	3446.2	3489.7	3531.4
(81.35) s	8.7392	8.8028	8.8649	8.9255	8.9848	9.0428	9.0996	9.1552	9.2098
v	4.8652	5.0194	5.1736	5.3277	5.4819	5.6360	5.7900	5.9441	6.0981
60.0 h	3196.7	3237.7	3278.8	3320.2	3361.9	3403.9	3446.1	3489.6	3531.3
(85.95) s	8.6549	8.7185	8.7806	8.8412	8.9005	8.9585	9.0153	9.0710	9.1256
v	3.6477	3.7634	3.8792	3.9948	4.1105	4.2261	4.3418	4.4574	4.5729
80.0 h	3196.4	3237.3	3278.5	3320.0	3361.7	3403.6	3445.9	3489.4	3531.1
(93.51) s	8.5217	8.5854	8.6475	8.7081	8.7675	8.8255	8.8823	8.9380	8.9926
v	2.9172	3.0098	3.1025	3.1951	3.2877	3.3803	3.4728	3.5653	3.6578
100.0 h	3196.0	3237.0	3278.2	3319.7	3361.4	3403.4	3445.6	3489.1	3530.9
(99.63) s	8.4183	8.4820	8.5442	8.6049	8.6642	8.7223	8.7791	8.8348	8.8894
v	1.9431	2.0051	2.0669	2.1286	2.1906	2.2524	2.3142	2.3759	2.4377
150.0 h	3195.1	3236.2	3277.5	3319.0	3360.7	3402.8	3445.0	3487.6	3530.4
(111.4) s	8.2301	8.2940	8.3562	8.4170	8.4764	8.5345	8.5914	8.6472	8.7018
v	1.4561	1.5027	1.5492	1.5956	1.6421	1.6885	1.7349	1.7812	1.8276
200.0 h	3194.2	3235.4	3276.7	3318.3	3360.1	3402.1	3444.5	3487.0	3529.9
(120.2) s	8.0964	8.1603	8.2226	8.2835	8.3429	8.4011	8.4581	8.5139	8.5686
v	0.9691	1.0003	1.0314	1.0625	1.0935	1.1245	1.1556	1.1865	1.2175
300.0 h	3192.4	3232.7	3275.2	3316.8	3358.8	3400.9	3443.3	3486.0	3528.9
(133.5) s	7.9072	7.9713	8.0338	8.0949	8.1545	8.2128	8.2698	8.3257	8.3805
v	0.7256	0.7491	0.7725	0.7959	0.8192	0.8426	0.8659	0.8892	0.9125
400.0 h	3190.6	3232.1	3273.6	3315.4	3357.4	3399.7	3442.1	3484.9	3527.8
(143.6) s	7.7723	7.8367	7.8994	7.9608	8.0203	8.0787	8.1359	8.1919	8.2468

**PROPERTIES OF SUPERHEATED STEAM AND COMPRESSED WATER
(TEMPERATURE AND PRESSURE)**

TABLE 2
Temperature, *t*, °C

Press.
p, kPa

540.	560.	580.	600.	625.	650.	700.	750.	800.	
375.27 3574.9 11.0693	384.50 3618.2 11.1218	393.74 3661.8 11.1735	402.97 3705.6 11.2243	414.50 3760.8 11.2866	426.04 3816.4 11.3476	449.12 3928.9 11.4663	472.19 4043.0 11.5807	495.27 <i>v</i> 4158.7 <i>h</i> 11.6911 <i>s</i>	1.0
250.18 3574.9 10.8821	256.34 3618.2 10.9347	262.49 3661.8 10.9864	268.64 3705.6 11.0372	276.33 3760.8 11.0995	284.03 3816.4 11.1605	299.41 3928.9 11.2792	314.79 4043.0 11.3933	330.18 <i>v</i> 4158.7 <i>h</i> 11.5040 <i>s</i>	1.5
187.64 3574.9 10.7494	192.25 3618.2 10.8019	196.87 3661.8 10.8536	201.48 3705.6 10.9044	207.25 3760.8 10.9667	213.02 3816.4 11.0277	224.56 3928.8 11.1464	236.10 4043.0 11.2608	247.63 <i>v</i> 4158.7 <i>h</i> 11.3712 <i>s</i>	2.0
125.09 3574.9 10.5622	128.17 3618.2 10.6148	131.24 3661.8 10.6665	134.32 3705.6 10.7173	138.17 3760.8 10.7796	142.01 3816.4 10.8406	149.70 3928.8 10.9593	157.40 4043.0 11.0736	165.09 <i>v</i> 4158.7 <i>h</i> 11.1841 <i>s</i>	3.0
93.817 3574.9 10.4295	96.124 3618.2 10.4820	98.432 3661.7 10.5337	100.74 3705.6 10.5845	103.62 3760.8 10.6468	106.51 3816.4 10.7078	112.28 3928.8 10.8265	118.05 4043.0 10.9409	123.82 <i>v</i> 4158.7 <i>h</i> 11.0513 <i>s</i>	4.0
75.053 3574.9 10.3265	76.899 3618.2 10.3790	78.745 3661.7 10.4307	80.592 3705.6 10.4815	82.899 3760.7 10.5438	85.207 3816.3 10.6049	89.822 3928.8 10.7235	94.438 4043.0 10.8379	99.093 <i>v</i> 4158.7 <i>h</i> 10.9483 <i>s</i>	5.0
62.544 3574.9 10.2423	64.082 3618.2 10.2949	65.621 3661.7 10.3466	67.159 3705.6 10.3973	69.082 3760.7 10.4596	71.005 3816.3 10.5207	74.852 3928.8 10.6394	78.698 4043.0 10.7537	82.544 <i>v</i> 4158.7 <i>h</i> 10.8642 <i>s</i>	6.0
46.907 3574.9 10.1095	48.061 3618.2 10.1621	49.215 3661.7 10.2138	50.369 3705.5 10.2646	51.811 3760.7 10.3269	53.254 3816.3 10.3879	56.138 3928.8 10.5066	59.023 4043.0 10.6210	61.908 <i>v</i> 4158.7 <i>h</i> 10.7314 <i>s</i>	8.0
37.525 3574.9 10.0065	38.448 3618.1 10.0591	39.372 3661.7 10.1108	40.295 3705.5 10.1616	41.449 3760.7 10.2239	42.603 3816.3 10.2849	44.910 3928.8 10.4036	47.218 4042.9 10.5180	49.526 <i>v</i> 4158.7 <i>h</i> 10.6284 <i>s</i>	10.0
25.016 3574.8 9.8194	25.632 3618.1 9.8719	26.247 3661.7 9.9236	26.863 3705.5 9.9744	27.632 3760.7 10.0367	28.401 3816.3 10.0978	29.940 3928.8 10.2164	31.478 4042.9 10.3308	33.017 <i>v</i> 4158.7 <i>h</i> 10.4413 <i>s</i>	15.0
18.761 3574.8 9.6865	19.223 3618.0 9.7391	19.685 3661.6 9.7908	20.146 3705.4 9.8416	20.723 3760.6 9.9039	21.300 3816.2 9.9650	22.455 3928.7 10.0836	23.609 4042.9 10.1980	24.762 <i>v</i> 4158.7 <i>h</i> 10.3085 <i>s</i>	20.0
12.507 3574.7 9.4993	12.815 3618.0 9.5519	13.122 3661.5 9.6036	13.430 3705.4 9.6544	13.815 3760.6 9.7167	14.200 3816.2 9.7778	14.969 3928.7 9.8965	15.739 4042.8 10.0109	16.508 <i>v</i> 4158.6 <i>h</i> 10.1213 <i>s</i>	30.0
9.3795 3574.6 9.3665	9.6104 3617.9 9.4191	9.8413 3661.4 9.4708	10.072 3705.3 9.5216	10.361 3760.5 9.5839	10.649 3816.1 9.6450	11.227 3928.6 9.7636	11.804 4042.8 9.8780	12.381 <i>v</i> 4158.6 <i>h</i> 9.9885 <i>s</i>	40.0
7.5031 3574.5 9.2634	7.6878 3617.8 9.3160	7.8726 3661.3 9.3677	8.0574 3705.2 9.4185	8.2883 3760.4 9.4808	8.5192 3816.0 9.5419	8.9810 3928.6 9.6606	9.4427 4042.7 9.7750	9.9044 <i>v</i> 4158.5 <i>h</i> 9.8855 <i>s</i>	50.0
6.2521 3574.4 9.1792	6.4062 3617.7 9.2318	6.5602 3661.3 9.2835	6.7141 3705.1 9.3343	6.9066 3760.3 9.3966	7.0991 3816.0 9.4577	7.4839 3928.5 9.5764	7.8687 4042.7 9.6908	8.2535 <i>v</i> 4158.5 <i>h</i> 9.8013 <i>s</i>	60.0
4.6885 3574.2 9.0462	4.8040 3617.5 9.0988	4.9196 3661.1 9.1506	5.0351 3705.0 9.2014	5.1795 3760.2 9.2637	5.3239 3815.8 9.3248	5.6126 3928.4 9.4436	5.9013 4042.6 9.5580	6.1899 <i>v</i> 4158.4 <i>h</i> 9.6685 <i>s</i>	80.0
3.7503 3574.0 8.9431	3.8428 3617.3 8.9957	3.9352 3660.9 9.0474	4.0277 3704.8 9.0982	4.1432 3760.0 9.1606	4.2988 3819.7 9.2217	4.4898 3928.2 9.3405	4.7208 4042.5 9.4549	4.9517 <i>v</i> 4158.3 <i>h</i> 9.5654 <i>s</i>	100.0
2.4994 3573.5 8.7555	2.5611 3616.9 8.8082	2.6228 3660.5 8.8599	2.6845 3704.4 8.9108	2.7616 3759.6 8.9732	2.8386 3819.3 9.0343	2.9927 3927.9 9.1531	3.1468 4042.2 9.2678	3.3008 <i>v</i> 4158.0 <i>h</i> 9.3781 <i>s</i>	150.0
1.8739 3573.0 8.6223	1.9202 3616.4 8.6750	1.9666 3660.0 8.7268	2.0129 3704.0 8.7776	2.0707 3759.3 8.8401	2.1286 3819.0 8.9012	2.2442 3927.6 9.0201	2.3598 4041.9 9.1346	2.4794 <i>v</i> 4157.8 <i>h</i> 9.2492 <i>s</i>	200.0
1.2485 3572.0 8.4343	1.2794 3615.5 8.4870	1.3103 3659.2 8.5389	1.3412 3703.2 8.5898	1.3799 3758.5 8.6523	1.4185 3814.2 8.7135	1.4957 3927.0 8.8325	1.5728 4041.4 8.9471	1.6499 <i>v</i> 4157.3 <i>h</i> 9.0577 <i>s</i>	300.0
0.9357 3571.1 8.3006	0.9590 3614.6 8.3534	0.9822 3658.3 8.4053	1.0054 3702.3 8.4563	1.0344 3757.7 8.5189	1.0634 3813.5 8.5802	1.1214 3926.4 8.6992	1.1793 4040.8 8.8139	1.2372 <i>v</i> 4156.9 <i>h</i> 8.9246 <i>s</i>	400.0

**PROPERTIES OF SUPERHEATED STEAM AND COMPRESSED WATER
(TEMPERATURE AND PRESSURE)**

TABLE 2
Temperature, t , °C

Press. p , kPa (t_s)		0.	20.	40.	60.	80.	100.	120.	140.	160.
500.0 (151.8)	v	0.0010000	0.0010015	0.0010076	0.0010169	0.0010290	0.0010435	0.0010605	0.0010800	0.38347
	h	0.5	84.3	167.9	251.5	335.3	419.4	503.9	589.2	2766.4
	s	-0.0001	0.2962	0.5719	0.8307	1.0790	1.3066	1.5273	1.7388	6.8631
600.0 (158.8)	v	0.0009999	0.0010015	0.0010075	0.0010169	0.0010289	0.0010434	0.0010604	0.0010799	0.31655
	h	0.6	84.4	168.0	251.6	335.4	419.4	504.0	589.3	2758.2
	s	-0.0001	0.2962	0.5719	0.8307	1.0749	1.3063	1.5272	1.7387	6.7640
800.0 (170.4)	v	0.0009998	0.0010014	0.0010075	0.0010168	0.0010288	0.0010433	0.0010603	0.0010798	0.0011021
	h	0.8	84.6	168.2	251.7	335.5	419.6	504.1	589.4	675.6
	s	-0.0001	0.2961	0.5718	0.8306	1.0748	1.3063	1.5270	1.7389	1.9423
1000.0 (179.9)	v	0.0009997	0.0010013	0.0010074	0.0010167	0.0010287	0.0010432	0.0010602	0.0010796	0.0011019
	h	1.0	84.8	168.3	251.9	335.7	419.7	504.3	589.5	675.7
	s	-0.0001	0.2961	0.5717	0.8305	1.0746	1.3062	1.5269	1.7383	1.9420
1500.0 (198.3)	v	0.0009995	0.0010010	0.0010071	0.0010165	0.0010285	0.0010430	0.0010599	0.0010793	0.0011016
	h	1.5	85.3	168.8	252.3	336.1	420.1	504.6	589.8	676.0
	s	-0.0000	0.2960	0.5715	0.8302	1.0743	1.3058	1.5264	1.7378	1.9414
2000.0 (212.4)	v	0.0009992	0.0010008	0.0010069	0.0010162	0.0010282	0.0010427	0.0010596	0.0010790	0.0011012
	h	2.0	85.7	169.2	252.7	336.5	420.5	505.0	590.2	676.3
	s	0.0000	0.2959	0.5713	0.8299	1.0740	1.3054	1.5260	1.7373	1.9408
3000.0 (233.8)	v	0.0009987	0.0010004	0.0010065	0.0010158	0.0010278	0.0010422	0.0010590	0.0010783	0.0011005
	h	3.0	86.7	170.1	253.6	337.3	421.2	505.7	590.8	676.9
	s	0.0001	0.2957	0.5709	0.8294	1.0733	1.3046	1.5251	1.7362	1.9396
4000.0 (250.3)	v	0.0009982	0.0009999	0.0010060	0.0010153	0.0010273	0.0010417	0.0010584	0.0010777	0.0010997
	h	4.0	87.6	171.0	254.4	338.1	422.0	506.4	591.5	677.5
	s	0.0002	0.2955	0.5706	0.8289	1.0726	1.3038	1.5242	1.7352	1.9385
5000.0 (263.9)	v	0.0009977	0.0009995	0.0010056	0.0010149	0.0010268	0.0010412	0.0010579	0.0010771	0.0010990
	h	5.1	88.6	171.9	255.3	338.8	422.7	507.1	592.1	678.1
	s	0.0002	0.2952	0.5702	0.8283	1.0720	1.3030	1.5233	1.7342	1.9373
6000.0 (275.5)	v	0.0009972	0.0009990	0.0010052	0.0010144	0.0010263	0.0010406	0.0010573	0.0010764	0.0010983
	h	6.1	89.5	172.7	256.1	339.6	423.5	507.8	592.8	678.6
	s	0.0003	0.2950	0.5698	0.8278	1.0713	1.3023	1.5224	1.7332	1.9361
8000.0 (295.0)	v	0.0009962	0.0009981	0.0010043	0.0010135	0.0010254	0.0010396	0.0010562	0.0010752	0.0010968
	h	8.1	91.4	174.5	257.8	341.2	425.0	509.2	594.1	679.8
	s	0.0004	0.2946	0.5690	0.8267	1.0700	1.3007	1.5206	1.7311	1.9338
10000.0 (311.0)	v	0.0009953	0.0009972	0.0010034	0.0010127	0.0010245	0.0010386	0.0010551	0.0010739	0.0010954
	h	10.1	93.2	176.3	259.4	342.8	426.5	510.6	595.4	681.0
	s	0.0005	0.2942	0.5682	0.8257	1.0687	1.2992	1.5188	1.7291	1.9315
15000.0 (342.1)	v	0.0009928	0.0009950	0.0010013	0.0010105	0.0010221	0.0010361	0.0010523	0.0010709	0.0010919
	h	15.1	97.9	180.7	263.6	346.8	430.3	514.2	598.7	684.0
	s	0.0007	0.2931	0.5663	0.8230	1.0655	1.2954	1.5144	1.7241	1.9238
20000.0 (365.7)	v	0.0009904	0.0009929	0.0009992	0.0010083	0.0010199	0.0010337	0.0010497	0.0010679	0.0010886
	h	20.1	102.5	185.1	267.8	350.8	434.0	517.7	602.0	687.1
	s	0.0008	0.2919	0.5643	0.8204	1.0623	1.2916	1.5101	1.7192	1.9203
30000.0	v	0.0009857	0.0009886	0.0009951	0.0010041	0.0010155	0.0010289	0.0010445	0.0010621	0.0010821
	h	30.0	111.7	193.8	276.1	358.7	441.6	524.9	608.7	693.3
	s	0.0008	0.2895	0.5604	0.8153	1.0560	1.2843	1.5017	1.7097	1.9095
40000.0	v	0.0009811	0.0009845	0.0009910	0.0010001	0.0010112	0.0010244	0.0010395	0.0010567	0.0010760
	h	39.7	120.8	202.5	284.5	366.7	449.2	532.1	615.5	699.6
	s	0.0004	0.2870	0.5565	0.8102	1.0498	1.2771	1.4935	1.7004	1.8991
50000.0	v	0.0009767	0.0009804	0.0009872	0.0009961	0.0010071	0.0010200	0.0010347	0.0010514	0.0010701
	h	49.3	129.9	211.2	292.8	374.7	456.8	539.4	622.4	705.9
	s	-0.0002	0.2843	0.5525	0.8052	1.0438	1.2701	1.4856	1.6915	1.8890
60000.0	v	0.0009723	0.0009765	0.0009834	0.0009923	0.0010031	0.0010157	0.0010301	0.0010464	0.0010645
	h	58.8	138.9	219.8	301.1	382.6	464.5	546.6	629.2	712.4
	s	-0.0012	0.2815	0.5486	0.8002	1.0379	1.2633	1.4778	1.6828	1.8793
80000.0	v	0.0009641	0.0009689	0.0009760	0.0009849	0.0009954	0.0010076	0.0010214	0.0010368	0.0010540
	h	77.5	156.6	236.9	317.6	398.5	479.7	561.3	643.2	725.5
	s	-0.0037	0.2756	0.5406	0.7904	1.0264	1.2501	1.4629	1.6661	1.8607
100000.0	v	0.0009565	0.0009616	0.0009690	0.0009779	0.0009882	0.0009999	0.0010132	0.0010279	0.0010443
	h	95.9	174.0	253.8	334.0	414.4	495.1	576.0	657.2	738.9
	s	-0.0067	0.2692	0.5325	0.7808	1.0152	1.2373	1.4486	1.6502	1.8431

**PROPERTIES OF SUPERHEATED STEAM AND COMPRESSED WATER
(TEMPERATURE AND PRESSURE)**

TABLE 2
Temperature, t , °C

Press.
 p , kPa

180.	200.	220.	240.	260.	280.	300.	320.	340.	
0.4045 2811.4 6.9647	0.4250 2855.1 7.0592	0.4450 2898.0 7.1478	0.4647 2940.1 7.2317	0.4841 2981.9 7.3115	0.5034 3023.4 7.3879	0.5226 3064.8 7.4614	0.5416 3106.1 7.5322	0.5606 <i>v</i> 3147.4 <i>h</i> 7.6008 <i>s</i>	500.0
0.3346 2804.8 6.8691	0.3520 2849.7 6.9662	0.3690 2893.5 7.0567	0.3857 2936.4 7.1419	0.4021 2978.7 7.2228	0.4183 3020.6 7.3000	0.4344 3062.3 7.3740	0.4504 3103.9 7.4454	0.4663 <i>v</i> 3145.4 <i>h</i> 7.5143 <i>s</i>	600.0
0.2471 2791.1 6.7122	0.2608 2838.6 6.8148	0.2740 2884.2 6.9094	0.2869 2928.6 6.9976	0.2995 2972.1 7.0807	0.3119 3014.9 7.1595	0.3241 3057.3 7.2348	0.3363 3099.4 7.3070	0.3483 <i>v</i> 3141.4 <i>h</i> 7.3767 <i>s</i>	800.0
0.1944 2776.5 6.5835	0.2059 2826.8 6.6922	0.2169 2874.6 6.7911	0.2276 2920.6 6.8825	0.2379 2965.2 6.9680	0.2480 3009.0 7.0485	0.2580 3052.1 7.1251	0.2678 3094.9 7.1984	0.2776 <i>v</i> 3137.4 <i>h</i> 7.2689 <i>s</i>	1000.0
0.0011271 763.4 2.1386	0.1324 2794.7 6.4508	0.1406 2848.6 6.5624	0.1483 2899.2 6.6630	0.1556 2947.3 6.7550	0.1628 2993.7 6.8405	0.1697 3038.9 6.9207	0.1765 3083.3 6.9967	0.1832 <i>v</i> 3127.0 <i>h</i> 7.0693 <i>s</i>	1500.0
0.0011267 763.6 2.1379	0.0011560 852.6 2.3300	0.1021 2819.9 6.3829	0.1084 2875.9 6.4943	0.1144 2928.1 6.5941	0.1200 2977.5 6.6852	0.1255 3025.0 6.7696	0.1308 3071.2 6.8487	0.1360 <i>v</i> 3116.3 <i>h</i> 6.9235 <i>s</i>	2000.0
0.0011258 764.1 2.1366	0.0011550 853.0 2.3284	0.0011891 943.9 2.5165	0.06816 2822.9 6.2241	0.07283 2885.1 6.3432	0.07712 2942.0 6.4479	0.08116 2995.1 6.5422	0.08500 3045.4 6.6285	0.08871 <i>v</i> 3093.9 <i>h</i> 6.7088 <i>s</i>	3000.0
0.0011249 764.6 2.1352	0.0011540 853.4 2.3268	0.0011878 944.1 2.5147	0.0012280 1037.7 2.7006	0.05172 2835.6 6.1353	0.05944 2902.0 6.2576	0.05883 2962.0 6.3642	0.06200 3017.5 6.4593	0.06499 <i>v</i> 3069.8 <i>h</i> 6.5461 <i>s</i>	4000.0
0.0011241 765.2 2.1339	0.0011530 853.8 2.3253	0.0011866 944.4 2.5129	0.0012264 1037.8 2.6984	0.0012750 1134.9 2.8840	0.04222 2856.9 6.0886	0.04530 2925.5 6.2105	0.04810 2987.2 6.3163	0.05070 <i>v</i> 3044.1 <i>h</i> 6.4106 <i>s</i>	5000.0
0.0011232 765.7 2.1325	0.0011519 854.2 2.3237	0.0011853 944.7 2.5110	0.0012249 1037.9 2.6962	0.0012729 1134.7 2.8813	0.03317 2804.9 5.9270	0.03614 2885.0 6.0692	0.03874 2954.2 6.1800	0.04111 <i>v</i> 3016.5 <i>h</i> 6.2913 <i>s</i>	6000.0
0.0011216 766.7 2.1299	0.0011500 855.1 2.3206	0.0011829 945.3 2.5075	0.0012218 1038.1 2.6919	0.0012687 1134.5 2.8761	0.0013277 1236.0 3.0629	0.02426 2786.8 5.7942	0.02681 2878.7 5.9519	0.02896 <i>v</i> 2955.3 <i>h</i> 6.0790 <i>s</i>	8000.0
0.0011199 767.8 2.1272	0.0011480 855.9 2.3176	0.0011805 945.9 2.5039	0.0012188 1038.4 2.6877	0.0012648 1134.2 2.8709	0.0013221 1235.0 3.0563	0.0013979 1343.4 3.2488	0.01926 2783.5 5.7145	0.02147 <i>v</i> 2883.4 <i>h</i> 5.8803 <i>s</i>	10000.0
0.0011159 770.4 2.1208	0.0011433 858.1 2.3102	0.0011748 947.6 2.4953	0.0012115 1039.2 2.6775	0.0012553 1134.0 2.8585	0.0013090 1232.9 3.0407	0.0013779 1338.3 3.2278	0.0014736 1454.3 3.4267	0.0016324 <i>v</i> 1593.3 <i>h</i> 3.6571 <i>s</i>	15000.0
0.0011120 773.1 2.1145	0.0011387 860.4 2.3030	0.0011693 949.3 2.4869	0.0012047 1040.3 2.6677	0.0012466 1134.0 2.8468	0.0012971 1231.4 3.0262	0.0013606 1334.3 3.2089	0.0014451 1445.6 3.3998	0.0015704 <i>v</i> 1572.4 <i>h</i> 3.6100 <i>s</i>	20000.0
0.0011046 778.7 2.1022	0.0011301 865.2 2.2891	0.0011590 953.1 2.4710	0.0011922 1042.8 2.6492	0.0012307 1134.7 2.8250	0.0012763 1229.7 2.9998	0.0013316 1328.7 3.1757	0.0014012 1433.6 3.3556	0.0014939 <i>v</i> 1547.7 <i>h</i> 3.5447 <i>s</i>	30000.0
0.0010976 784.4 2.0905	0.0011220 870.2 2.2758	0.0011495 957.2 2.4560	0.0011808 1045.8 2.6320	0.0012166 1136.3 2.8050	0.0012583 1229.2 2.9761	0.0013077 1325.4 3.1469	0.0013677 1425.9 3.3193	0.0014434 <i>v</i> 1532.9 <i>h</i> 3.4965 <i>s</i>	40000.0
0.0010910 790.2 2.0793	0.0011144 875.4 2.2632	0.0011407 961.6 2.4417	0.0011703 1049.2 2.6158	0.0012040 1138.5 2.7864	0.0012426 1229.8 2.9545	0.0012874 1323.7 3.1213	0.0013406 1421.0 3.2882	0.0014055 <i>v</i> 1523.0 <i>h</i> 3.4572 <i>s</i>	50000.0
0.0010847 796.2 2.0684	0.0011073 880.8 2.2511	0.0011325 966.3 2.4281	0.0011607 1053.0 2.6005	0.0011924 1141.2 2.7690	0.0012285 1231.1 2.9345	0.0012698 1323.2 3.0981	0.0013179 1418.0 3.2606	0.0013751 <i>v</i> 1516.3 <i>h</i> 3.4236 <i>s</i>	60000.0
0.0010731 808.4 2.0478	0.0010941 891.9 2.2281	0.0011174 976.2 2.4026	0.0011433 1061.4 2.5720	0.0011720 1147.8 2.7370	0.0012041 1233.4 2.8985	0.0012401 1324.7 3.0570	0.0012809 1415.7 3.2130	0.0013280 <i>v</i> 1508.6 <i>h</i> 3.3671 <i>s</i>	80000.0
0.0010623 820.9 2.0283	0.0010821 903.5 2.2067	0.0011039 986.7 2.3789	0.0011279 1070.7 2.5458	0.0011543 1155.6 2.7081	0.0011833 1241.5 2.8663	0.0012155 1328.7 3.0210	0.0012514 1416.9 3.1723	0.0012921 <i>v</i> 1505.9 <i>h</i> 3.3200 <i>s</i>	100000.0

**PROPERTIES OF SUPERHEATED STEAM AND COMPRESSED WATER
(TEMPERATURE AND PRESSURE)**

TABLE 2
Temperature, t , °C

Press. p , kPa (t_s)	360.	380.	400.	420.	440.	460.	480.	500.	520.
500.0 (151.8)	v 0,5795 h 3188,8 s 7,6673	0,5984 3230,4 7,7319	0,6172 3272,1 7,7948	0,6359 3314,0 7,8561	0,6547 3356,1 7,9160	0,6734 3398,4 7,9745	0,6921 3441,0 8,0318	0,7108 3483,8 8,0879	0,7294 3526,8 8,1428
600.0 (158.8)	v 0,4821 h 3187,0 s 7,5810	0,4979 3228,7 7,6459	0,5136 3270,6 7,7090	0,5293 3312,6 7,7705	0,5450 3354,8 7,8305	0,5606 3397,2 7,8891	0,5762 3439,8 7,9465	0,5918 3482,7 8,0027	0,6074 3525,8 8,0577
800.0 (170.4)	v 0,3603 h 3183,4 s 7,4441	0,3723 3225,4 7,5094	0,3842 3267,5 7,5729	0,3960 3309,7 7,6347	0,4078 3352,1 7,6950	0,4196 3394,7 7,7539	0,4314 3437,5 7,8115	0,4432 3480,5 7,8678	0,4549 3523,7 7,9230
1000.0 (179.9)	v 0,2873 h 3179,7 s 7,3368	0,2969 3222,0 7,4027	0,3065 3264,4 7,4665	0,3160 3306,9 7,5287	0,3256 3349,5 7,5893	0,3350 3392,2 7,6484	0,3445 3435,1 7,7062	0,3540 3478,3 7,7627	0,3634 3521,6 7,8181
1500.0 (198.3)	v 0,1898 h 3170,4 s 7,1389	0,1964 3213,5 7,2060	0,2029 3256,6 7,2709	0,2094 3299,7 7,3340	0,2158 3342,8 7,3953	0,2223 3386,0 7,4550	0,2287 3429,3 7,5133	0,2350 3472,8 7,5703	0,2414 3516,5 7,6261
2000.0 (212.4)	v 0,1411 h 3160,8 s 6,9950	0,1461 3204,9 7,0635	0,1511 3248,7 7,1296	0,1561 3292,4 7,1935	0,1610 3336,0 7,2555	0,1659 3379,7 7,3159	0,1707 3423,4 7,3748	0,1756 3467,3 7,4323	0,1804 3511,3 7,4885
3000.0 (233.8)	v 0,09232 h 3140,9 s 6,7844	0,09584 3187,0 6,8561	0,09931 3232,5 6,9246	0,1027 3277,5 6,9906	0,1061 3322,3 7,0543	0,1095 3367,0 7,1160	0,1128 3411,6 7,1760	0,1161 3456,2 7,2345	0,1194 3500,9 7,2916
4000.0 (250.3)	v 0,06787 h 3119,9 s 6,6265	0,07066 3168,4 6,7019	0,07338 3215,7 6,7733	0,07604 3262,3 6,8414	0,07866 3308,3 6,9069	0,08125 3354,0 6,9702	0,08381 3399,6 7,0314	0,08634 3445,0 7,0909	0,08886 3490,4 7,1489
5000.0 (263.9)	v 0,05316 h 3097,6 s 6,4966	0,05551 3148,8 6,5762	0,05779 3198,3 6,6508	0,06001 3246,5 6,7215	0,06218 3294,0 6,7890	0,06431 3340,9 6,8538	0,06642 3387,4 6,9164	0,06849 3433,7 6,9770	0,07055 3479,8 7,0360
6000.0 (275.5)	v 0,04330 h 3074,0 s 6,3836	0,04539 3128,3 6,4680	0,04738 3180,1 6,5462	0,04931 3230,3 6,6196	0,05118 3279,3 6,6893	0,05302 3327,4 6,7559	0,05482 3375,0 6,8199	0,05659 3422,2 6,8818	0,05834 3469,1 6,9417
8000.0 (295.0)	v 0,03088 h 3022,7 s 6,1872	0,03265 3084,2 6,2828	0,03431 3141,6 6,3694	0,03589 3196,2 6,4493	0,03740 3248,7 6,5240	0,03887 3299,7 6,5945	0,04030 3349,6 6,6617	0,04170 3398,8 6,7262	0,04308 3447,4 6,7883
10000.0 (311.0)	v 0,02331 h 2964,8 s 6,0110	0,02493 3035,7 6,1213	0,02641 3099,9 6,2182	0,02779 3159,7 6,3057	0,02911 3216,2 6,3861	0,03036 3270,5 6,4612	0,03158 3323,2 6,5321	0,03276 3374,6 6,5994	0,03391 3425,1 6,6640
15000.0 (342.1)	v 0,01256 h 2770,8 s 5,5677	0,01428 2887,7 5,7497	0,01566 2979,1 5,8876	0,01686 3057,0 6,0016	0,01794 3126,9 6,1010	0,01895 3191,5 6,1904	0,01989 3252,4 6,2724	0,02080 3310,6 6,3487	0,02166 3366,8 6,4204
20000.0 (365.7)	v 0,0018269 h 1742,9 s 3,8835	0,008246 2660,2 5,3165	0,009947 2820,5 5,5585	0,01120 2932,9 5,7232	0,01224 3023,7 5,8523	0,01315 3102,7 5,9616	0,01399 3174,4 6,0581	0,01477 3241,1 6,1456	0,01551 3304,2 6,2262
30000.0	v 0,0016285 h 1678,0 s 3,7541	0,001874 1837,7 4,0021	0,002831 2161,8 4,4896	0,004921 2558,0 5,0706	0,006227 2754,0 5,3499	0,007189 2887,7 5,5349	0,007985 2993,9 5,6779	0,008681 3085,0 5,7972	0,009310 3166,6 5,9014
40000.0	v 0,0015425 h 1650,5 s 3,6856	0,001682 1776,4 3,8814	0,001909 1934,1 4,1190	0,002371 2145,7 4,4285	0,003200 2399,4 4,7893	0,004137 2617,1 5,0906	0,004941 2779,8 5,3097	0,005616 2906,8 5,4762	0,006205 3013,7 5,6128
50000.0	v 0,0014862 h 1633,9 s 3,6355	0,001589 1746,8 3,8110	0,001729 1877,7 4,0083	0,001938 2026,6 4,2262	0,002269 2199,7 4,4723	0,002747 2387,2 4,7316	0,003308 2564,9 4,9709	0,003882 2723,0 5,1782	0,004408 2854,9 5,3466
60000.0	v 0,0014444 h 1622,8 s 3,5948	0,001528 1728,4 3,7589	0,001632 1847,3 3,9383	0,001771 1975,0 4,1252	0,001962 2113,5 4,3221	0,002226 2263,2 4,5291	0,002565 2418,8 4,7385	0,002952 2570,6 4,9374	0,003358 2712,6 5,1189
80000.0	v 0,0013833 h 1609,7 s 3,5296	0,001445 1707,0 3,6807	0,001518 1814,2 3,8425	0,001605 1924,1 4,0033	0,001710 2036,6 4,1633	0,001841 2152,5 4,3237	0,001999 2272,8 4,4855	0,002188 2397,4 4,6488	0,002405 2524,2 4,8100
100000.0	v 0,0013388 h 1603,4 s 3,4767	0,001390 1696,3 3,6211	0,001446 1797,6 3,7738	0,001511 1899,0 3,9223	0,001587 2000,3 4,0664	0,001675 2102,7 4,2079	0,001777 2207,7 4,3492	0,001893 2316,1 4,4913	0,002024 2427,2 4,6331

**PROPERTIES OF SUPERHEATED STEAM AND COMPRESSED WATER
(TEMPERATURE AND PRESSURE)**

**TABLE 2
Temperature, t, °C**

									Press. <i>p</i> , kPa
540.	560.	580.	600.	625.	650.	700.	750.	800.	
0.7481 3570.1 8.1967	0.7667 3613.6 8.2496	0.7853 3657.4 8.3016	0.8039 3701.5 8.3526	0.8272 3757.0 8.4152	0.8504 3812.8 8.4766	0.8968 3925.8 8.5957	0.9432 4040.3 8.7105	0.9896 v 4156.4 h 8.8213 s	500.0
0.6230 3569.1 8.1117	0.6386 3612.7 8.1647	0.6541 3656.6 8.2167	0.6696 3700.7 8.2678	0.6890 3756.2 8.3305	0.7084 3812.1 8.3919	0.7471 3925.1 8.5111	0.7858 4039.8 8.6259	0.8245 v 4155.0 h 8.7368 s	600.0
0.4666 3567.2 7.9771	0.4783 3610.9 8.0302	0.4900 3654.8 8.0824	0.5017 3699.1 8.1336	0.5163 3754.7 8.1964	0.5309 3810.7 8.2579	0.5600 3923.9 8.3773	0.5891 4038.7 8.4923	0.6181 v 4155.0 h 8.6033 s	800.0
0.3728 3565.2 7.8724	0.3822 3609.0 7.9256	0.3916 3653.1 7.9779	0.4010 3697.4 8.0292	0.4127 3753.1 8.0921	0.4244 3809.3 8.1537	0.4477 3922.7 8.2734	0.4710 4037.6 8.3865	0.4943 v 4154.1 h 8.4997 s	1000.0
0.2477 3560.4 7.6808	0.2540 3604.5 7.7343	0.2604 3648.8 7.7869	0.2667 3693.3 7.8385	0.2745 3749.3 7.9017	0.2824 3805.7 7.9636	0.2980 3919.6 8.0838	0.3136 4034.9 8.1993	0.3292 v 4151.7 h 8.3108 s	1500.0
0.1852 3555.5 7.5435	0.1900 3599.9 7.5974	0.1947 3644.4 7.6503	0.1995 3689.2 7.7022	0.2054 3745.5 7.7657	0.2114 3802.1 7.8279	0.2232 3916.5 7.9485	0.2349 4032.2 8.0645	0.2467 v 4149.4 h 8.1763 s	2000.0
0.1226 3545.7 7.3474	0.1259 3590.6 7.4020	0.1291 3635.7 7.4554	0.1323 3681.0 7.5079	0.1364 3737.8 7.5721	0.1404 3795.0 7.6349	0.1483 3910.3 7.7564	0.1562 4028.8 7.8733	0.1641 v 4144.7 h 7.9857 s	3000.0
0.09135 3535.8 7.2055	0.09384 3581.4 7.2608	0.09631 3627.0 7.3149	0.09876 3672.8 7.3680	0.1018 3730.2 7.4328	0.1049 3787.9 7.4961	0.1109 3904.1 7.6187	0.1169 4021.4 7.7363	0.1229 v 4140.0 h 7.8495 s	4000.0
0.07259 3525.9 7.0934	0.07461 3572.0 7.1494	0.07662 3618.2 7.2042	0.07862 3664.5 7.2578	0.08109 3722.5 7.3233	0.08356 3780.7 7.3872	0.08845 3897.9 7.5108	0.09320 4016.1 7.6292	0.09809 v 4135.3 h 7.7431 s	5000.0
0.06008 3515.9 7.0000	0.06179 3562.7 7.0568	0.06349 3609.4 7.1122	0.06518 3656.2 7.1664	0.06728 3714.8 7.2326	0.06936 3773.5 7.2971	0.07348 3891.7 7.4217	0.07755 4010.7 7.5409	0.08159 v 4130.7 h 7.6594 s	6000.0
0.04443 3495.7 6.8484	0.04577 3543.8 6.9068	0.04709 3591.7 6.9636	0.04839 3639.5 7.0191	0.05001 3699.3 7.0866	0.05161 3759.2 7.1523	0.05477 3879.2 7.2790	0.05788 3999.9 7.3999	0.06096 v 4121.3 h 7.5158 s	8000.0
0.03504 3475.1 6.7261	0.03615 3524.5 6.7863	0.03724 3573.7 6.8446	0.03832 3622.7 6.9013	0.03965 3683.8 6.9703	0.04096 3744.7 7.0373	0.04355 3866.8 7.1660	0.04609 3989.1 7.2886	0.04858 v 4112.0 h 7.4098 s	10000.0
0.02250 3421.4 6.4885	0.02331 3475.0 6.5535	0.02411 3527.7 6.6160	0.02488 3579.8 6.6764	0.02584 3644.3 6.7492	0.02677 3708.3 6.8195	0.02859 3835.4 6.9536	0.03036 3962.1 7.0806	0.03209 v 4088.6 h 7.2013 s	15000.0
0.01621 3364.7 6.3015	0.01688 3423.0 6.3724	0.01753 3479.9 6.4398	0.01816 3535.5 6.5043	0.01893 3603.8 6.5814	0.01967 3671.1 6.6554	0.02111 3803.8 6.7953	0.02250 v 3935.0 h 6.9267	0.02385 v 4065.3 h 7.0511 s	20000.0
0.009890 3241.7 5.9949	0.01043 3312.1 6.0805	0.01095 3378.9 6.1597	0.01144 3443.0 6.2340	0.01202 3520.2 6.3212	0.01258 3595.0 6.4033	0.01365 3739.7 6.5560	0.01465 3880.3 6.6970	0.01562 v 4018.5 h 6.8288 s	30000.0
0.006735 3108.0 5.7302	0.007219 3193.4 5.8340	0.007667 3272.4 5.9276	0.008088 3346.4 6.0135	0.008584 3433.8 6.1122	0.009053 3517.0 6.2035	0.009930 3674.8 6.3701	0.01075 3825.5 6.5210	0.01152 v 3971.7 h 6.6606 s	40000.0
0.004888 2988.9 5.4886	0.005328 3070.7 5.6124	0.005734 3163.2 5.7221	0.006111 3248.3 5.8207	0.006550 3346.8 5.9320	0.006960 3438.9 6.0331	0.007720 3610.2 6.2138	0.008421 3770.9 6.3749	0.009076 v 3925.3 h 6.5222 s	50000.0
0.003755 2838.3 5.2755	0.004135 2951.7 5.4132	0.004496 3055.8 5.5367	0.004835 3151.6 5.6477	0.005229 3261.4 5.7717	0.005596 3362.4 5.8827	0.006269 3547.0 6.0775	0.006885 3717.4 6.2483	0.007460 v 3879.6 h 6.4031 s	60000.0
0.002641 2648.2 4.9650	0.002886 2765.1 5.1072	0.003132 2874.9 5.2374	0.003379 2980.3 5.3595	0.003692 3104.6 5.4999	0.003974 3220.3 5.6270	0.004519 3428.7 5.8470	0.005017 3516.7 6.0354	0.005481 v 3792.8 h 6.2034 s	80000.0
0.002168 2538.6 4.7719	0.002326 2648.2 4.9050	0.002493 2754.5 5.0311	0.002668 2857.5 5.1505	0.002891 2985.8 5.2954	0.003106 3105.3 5.4267	0.003536 3324.4 5.6579	0.003957 3528.1 5.8600	0.004341 v 3714.3 h 6.0397 s	100000.0

COMMON CONVERSIONS

1 barrel (35 Imp gal) (42 US gal)	= 159.1 litres	1 kilowatt · hour	= 3600 kilojoules
1 gallon (Imp)	= 1.20094 gallon (US)	1 Newton	= 1 kg-m/s ²
1 horsepower (boiler)	= 9809.6 watts	1 therm	= 10 ⁵ Btu
1 horsepower	= 2545 Btu/hour	1 ton (refrigerant)	= 12002.84 Btu/hour
1 horsepower	= 0.746 kilowatts	1 ton (refrigerant)	= 3516.8 watts
1 joule	= 1 N-m	1 watt	= 1 joule/second
Kelvin	= (°C + 273.15)	Rankine	= (°F + 459.67)

Cubes

1 yd ³	= 27 ft ³
1 ft ³	= 1728 in ³
1 cm ³	= 1000 mm ³
1 m ³	= 10 ⁶ cm ³
1 m ³	= 1000 L

Squares

1 yd ²	= 9 ft ²
1 ft ²	= 144 in ²
1 cm ²	= 100 mm ²
1 m ²	= 10000 cm ²

SI PREFIXES

Prefix	Symbol	Magnitude	Factor
tera	T	1 000 000 000 000	10 ¹²
giga	G	1 000 000 000	10 ⁹
mega	M	1 000 000	10 ⁶
kilo	k	1 000	10 ³
hecto	h	100	10 ²
deca	da	10	10 ¹
deci	d	0.1	10 ⁻¹
centi	c	0.01	10 ⁻²
milli	m	0.001	10 ⁻³
micro	u	0.000 001	10 ⁻⁶
nano	n	0.000 000 001	10 ⁻⁹
pica	p	0.000 000 000 001	10 ⁻¹²

UNIT CONVERSION TABLES

METRIC TO IMPERIAL

FROM	SYMBOL	TO	SYMBOL	MULTIPLY BY
amperes/square centimetre	A/cm ²	amperes/square inch	A/in ²	6.452
Celsius	°C	Fahrenheit	°F	(°C × 9/5) + 32
centimetres	cm	inches	in	0.3937
cubic centimetres	cm ³	cubic inches	in ³	0.06102
cubic metres	m ³	cubic foot	ft ³	35.314
grams	g	ounces	oz	0.03527
grams	g	pounds	lb	0.0022
grams/litre	g/L	pounds/cubic foot	lb/ft ³	0.06243
joules	J	Btu	Btu	9.480 × 10 ⁻⁴
joules	J	foot-pounds	ft-lb	0.7376
joules	J	horsepower-hours	hp-h	3.73 × 10 ⁻⁷
joules/metre, (Newtons)	J/m, N	pounds	lb	0.2248
kilograms	kg	pounds	lb	2.205
kilograms	kg	tons (long)	ton	9.842 × 10 ⁻⁴
kilograms	kg	tons (short)	tn	1.102 × 10 ⁻³
kilometres	km	miles (statute)	mi	0.6214
kilopascals	kPa	atmospheres	atm	9.87 × 10 ⁻³
kilopascals	kPa	inches of mercury (@ 32°F)	in Hg	0.2953
kilopascals	kPa	inches of water (@ 4°C)	in H ₂ O	4.0147
kilopascals	kPa	pounds/square inch	psi	0.1450
kilowatts	kW	foot-pounds/second	ft-lb/s	737.6
kilowatts	kW	horsepower	hp	1.341
kilowatt-hours	kWh	Btu	Btu	3413
litres	L	cubic foot	ft ³	0.03531
litres	L	gallons (Imp)	gal (Imp)	0.21998
litres	L	gallons (US)	gal (US)	0.2642
litres/second	L/s	cubic foot/minute	cfm	2.1186
lumen/square metre	lm/m ²	lumen/square foot	lm/ft ²	0.09290
lux, lumen/square metre	lx, lm/m ²	footcandles	fc	0.09290
metres	m	foot	ft	3.281
metres	m	yard	yd	1.09361
parts per million	ppm	grains/gallon (Imp)	gr/gal (Imp)	0.07
parts per million	ppm	grains/gallon (US)	gr/gal (US)	0.05842
permeance (metric)	PERM	permeance (Imp)	perm	0.01748
square centimetres	cm ²	square inches	in ²	0.1550
square metres	m ²	square foot	ft ²	10.764
square metres	m ²	square yards	yd ²	1.196
tonne (metric)	t	pounds	lb	2204.6
watt	W	Btu/hour	Btu/h	3.413
watt	W	lumen	lm	668.45

UNIT CONVERSION TABLES

IMPERIAL TO METRIC

FROM	SYMBOL	TO	SYMBOL	MULTIPLY BY
ampere/in ²	A/in ²	ampere/cm ²	A/cm ²	0.1550
atmospheres	atm	kilopascals	kPa	101.325
British Thermal Unit	Btu	joules	J	1054.8
Btu	Btu	kilogram-metre	kg-m	107.56
Btu	Btu	kilowatt-hour	kWh	2.928×10^{-4}
Btu/hour	Btu/h	watt	W	0.2931
calorie, gram	cal or g-cal	joules	J	4.186
chain	chain	metre	m	20.11684
cubic foot	ft ³	cubic metre	m ³	0.02832
cubic foot	ft ³	litre	L	28.32
cubic foot/minute	cfm	litre/second	L/s	0.47195
cycle/second	c/s	Hertz	Hz	1.00
Fahrenheit	°F	Celsius	°C	$(°F-32)/1.8$
foot	ft	metre	m	0.3048
footcandle	fc	lux, lumen/ square metre	lx, lm/m ²	10.764
footlambert	fL	candela/square metre	cd/m ²	3.42626
foot-pounds	ft-lb	joule	J	1.356
foot-pounds	ft-lb	kilogram-metres	kg-m	0.1383
foot-pounds/second	ft-lb/s	kilowatt	kW	1.356×10^{-3}
gallons (Imp)	gal (Imp)	litres	L	4.546
gallons (US)	gal (US)	litres	L	3.785
grains/gallon (Imp)	gr/gal (Imp)	parts per million	ppm	14.286
grains/gallon (US)	gr/gal (US)	parts per million	ppm	17.118
horsepower	hp	watts	W	745.7
horsepower-hours	hp-h	joules	J	2.684×10^6
inches	in	centimetres	cm	2.540
inches of Mercury (@ 32°F)	in Hg	kilopascals	kPa	3.386
inches of water (@ 4°C)	in H ₂ O	kilopascals	kPa	0.2491

UNIT CONVERSION TABLES

IMPERIAL TO METRIC (cont'd)

FROM	SYMBOL	TO	SYMBOL	MULTIPLY BY
lamberts	* L	candela/square metre	cd/m ²	3.183
lumen/square foot	lm/ft ²	lumen/square metre	lm/m ²	10.76
lumen	lm	watt	W	0.001496
miles (statute)	mi	kilometres	km	1.6093
ounces	oz	grams	g	28.35
perm (at 0°C)	perm	kilogram per pascal-second-square metre	kg/Pa-s-m ² (PERM)	5.721 × 10 ⁻¹¹
perm (at 23°C)	perm	kilogram per pascal-second-square metre	kg/Pa-s-m ² (PERM)	5.745 × 10 ⁻¹¹
perm-inch (at 0°C)	perm. in.	kilogram per pascal-second-metre	kg/Pa-s-m	1.4532 × 10 ⁻¹²
perm-inch (at 23°C)	perm. in.	kilogram per pascal-second-metre	kg/Pa-s-m	1.4593 × 10 ⁻¹²
pint (Imp)	pt	litre	L	0.56826
pounds	lb	grams	g	453.5924
pounds	lb	joules/metre, (Newtons)	J/m, N	4.448
pounds	lb	kilograms	kg	0.4536
pounds	lb	tonne (metric)	t	4.536 × 10 ⁻⁴
pounds/cubic foot	lb/ft ³	grams/litre	g/L	16.02
pounds/square inch	psi	kilopascals	kPa	6.89476
quarts	qt	litres	L	1.1365
slug	slug	kilograms	kg	14.5939
square foot	ft ²	square metre	m ²	0.09290
square inches	in ²	square centimetres	cm ²	6.452
square yards	yd ²	square metres	m ²	0.83613
tons (long)	ton	kilograms	kg	1016
tons (short)	tn	kilograms	kg	907.185
yards	yd	metres	m	0.9144

* "L" as used in Lighting

The following typical values for conversion factors may be used when actual data are unavailable. The MJ and Btu equivalencies are heats of combustion. Hydrocarbons are shown at the higher heating value, wet basis. Some items listed are typically feedstocks, but are included for completeness and as a reference source. The conversion factors for coal are approximate since the heating value of a specific coal is dependent on the particular mine from which it is obtained.

ENERGY TYPE	METRIC	IMPERIAL
COAL		
— metallurgical	29 000 megajoules/tonne	25.0×10^6 Btu/ton
— anthracite	30 000 megajoules/tonne	25.8×10^6 Btu/ton
— bituminous	32 100 megajoules/tonne	27.6×10^6 Btu/ton
— sub-bituminous	22 100 megajoules/tonne	19.0×10^6 Btu/ton
— lignite	16 700 megajoules/tonne	14.4×10^6 Btu/ton
COKE		
— metallurgical	30 200 megajoules/tonne	26.0×10^6 Btu/ton
— petroleum		
— raw	23 300 megajoules/tonne	20.0×10^6 Btu/ton
— calcined	32 600 megajoules/tonne	28.0×10^6 Btu/ton
PITCH	37 200 megajoules/tonne	32.0×10^6 Btu/ton
CRUDE OIL	38.5 megajoules/litre	5.8×10^6 Btu/bbl
No. 2 OIL	38.68 megajoules/litre	5.88×10^6 Btu/bbl $.168 \times 10^6$ Btu/IG
No. 4 OIL	40.1 megajoules/litre	6.04×10^6 Btu/bbl $.173 \times 10^6$ Btu/IG
No. 6 OIL (RESID. BUNKER C)		
@ 2.5% sulphur	42.3 megajoules/litre	6.38×10^6 Btu/bbl $.182 \times 10^6$ Btu/IG
@ 1.0% sulphur	40.5 megajoules/litre	6.11×10^6 Btu/bbl $.174 \times 10^6$ Btu/IG
@ .5% sulphur	40.2 megajoules/litre	6.05×10^6 Btu/bbl $.173 \times 10^6$ Btu/IG
KEROSENE	37.68 megajoules/litre	$.167 \times 10^6$ Btu/IG
DIESEL FUEL	38.68 megajoules/litre	$.172 \times 10^6$ Btu/IG
GASOLINE	36.2 megajoules/litre	$.156 \times 10^6$ Btu/IG
NATURAL GAS	37.2 megajoules/m ³	1.00×10^6 Btu/MCF
PROPANE	50.3 megajoules/kg 26.6 megajoules/litre	$.02165 \times 10^6$ Btu/lb $.1145 \times 10^6$ Btu/IG
ELECTRICITY	3.6 megajoules/kWh	$.003413 \times 10^6$ Btu/kWh

Boiler Efficiency Test Worksheet 6-1

Company: _____ Date: _____
 Location: _____ By: _____
 Boiler Number: _____ Fuel Fired: _____
 Rated Capacity: _____ Test No. _____

Pressures & Temperatures

Steam pressure at boiler outlet kPa(abs) (1)
 Steam temperature at boiler outlet °C (2)
 Water temperature at boiler inlet °C (3)
 Combustion air temperature °C (4)
 Fuel temperature °C (5)
 Gas temperature leaving boiler °C (6)

Unit Quantities

Enthalpy of steam at boiler outlet kJ/kg (7)
 Enthalpy of feedwater to boiler kJ/kg (8)
 Heat absorbed per kg of steam (7) - (8) kJ/kg (9)
 Higher heating value of fuel (state units) (10)

Hourly Quantities

Actual water evaporated kg/h (11)
 Rate of fuel firing (state units) (12)
 Total heat input (12) x (10)* = _____ x _____ MJ/h (13)
 Total heat output $\frac{(11) \times (9)}{1000} = \frac{\quad \times \quad}{1000}$ MJ/h (14)
 Direct efficiency $\frac{(14)}{(13)} \times 100 = \frac{\quad \times \quad}{\quad} \times 100$ % (15)

*Units of (12) x (10) must equal MJ/h

Flue Gas Analysis

	% Volume	
CO ₂	(16)
O ₂	(17)
CO	(18)
N ₂ by difference	(19)
Excess air	(20)

Heat Loss Efficiency

	% Loss of fired fuel	
Heat loss to dry gas and H ₂ O (Figure 9 for natural gas and Figure 10 for No. 2 oil)	(21)
Heat loss to radiation (Figure 12)	(22)
Unmeasured losses	(23)
Total losses (21) + (22) + (23)	(24)
Indirect efficiency 100 - (24)	(25)

