

This document was produced
by scanning the original publication.

Ce document est le produit d'une
numérisation par balayage
de la publication originale.

ENERGY
MANAGEMENT
SERIES

18

FOR INDUSTRY
COMMERCE
AND INSTITUTIONS

Architectural Considerations

To the Reader

These manuals provide detailed information on a wide range of energy management topics. Because they were produced in the late 1980s, references to energy prices and to some energy management techniques are dated. Nonetheless, the manuals provide practitioners with useful mathematical equations and general information on proven techniques and technologies, as well as examples of how to save energy.

Avis au lecteur

Ces manuels contiennent de l'information détaillée sur de nombreux aspects de la gestion énergétique. Comme ils ont été produits à la fin des années 80, les références aux prix de l'énergie et à certaines techniques de gestion énergétique ne sont plus à jour. Le lecteur y trouvera toutefois des équations mathématiques utiles et des renseignements généraux sur diverses techniques et technologies éprouvées, ainsi que des exemples de mesures à prendre pour économiser l'énergie.



Energy, Mines and
Resources Canada

Énergie, Mines et
Ressources Canada

Canada

PREFACE

Much has been learned about the art and science of managing energy during the past decade. Today, energy management is a seriously applied discipline within the management process of most successful companies.

Initially, in the early 1970's, energy conservation programs were established to alleviate threatened shortages and Canada's dependency on off-shore oil supplies. However, dramatic price increases quickly added a new meaning to the term "energy conservation" — reduce energy costs!

Many industrial, commercial and institutional organizations met the challenge and reduced energy costs by up to 50%. Improved energy use efficiency was achieved by such steps as employee awareness programs, improved maintenance procedures, by simply eliminating waste, as well as by undertaking projects to upgrade or improve facilities and equipment.

In order to obtain additional energy savings at this juncture, a greater knowledge and understanding of technical theory and its application is required in addition to energy efficiency equipment itself.

At the request of the Canadian Industry Program for Energy Conservation, the Commercial and Institutional Task Force Program and related trade associations, the Industrial Energy Division of the Department of Energy, Mines and Resources Canada has prepared a series of energy management and technical manuals.

The purpose of these manuals is to help managers and operating personnel recognize energy management opportunities within their organizations. They provide the practitioner with mathematical equations, general information on proven techniques and technology, together with examples of how to save energy.

For further information concerning the manuals listed below or material used at seminars/workshops including actual case studies, please write to:

Business & Government Energy Management Division
Energy Conservation Branch
Department of Energy, Mines and Resources
580 Booth Street
Ottawa, Ontario
K1A 0E4

Energy Management/Employee Participation	9 Heating and Cooling Equipment (Steam and Water)
Conducting an Energy Audit	10 Heating Ventilating and Air Conditioning
Financial Analysis	11 Refrigeration and Heat Pumps
Energy Accounting	12 Water and Compressed Air Systems
Waste Heat Recovery	13 Fans and Pumps
1 Process Insulation	14 Compressors and Turbines
2 Lighting	15 Measuring, Metering and Monitoring
3 Electrical	16 Automatic Controls
4 Energy Efficient Electric Motors	17 Materials Handling and On-Site Transportation Equipment
5 Combustion	18 Architectural Considerations
6 Boiler Plant Systems	19 Thermal Storage
7 Process Furnaces, Dryers and Kilns	20 Planning and Managing Guide
8 Steam and Condensate Systems	

© Minister of Supply and Services Canada 1987

Available in Canada through

Associated Bookstores
and other booksellers

or by mail from

Canadian Government Publishing Centre
Supply and Services Canada
Ottawa, Canada K1A 0S9

Catalogue No. M91-6/18E

Canada: \$5.50

ISBN 0-662-14170-9

Other Countries: \$6.60

Price subject to change without notice

All rights reserved. No part of this publication may be reproduced, stored in a retrieval system, or transmitted by any means, electronic, mechanical, photocopying, recording or otherwise, without the prior written permission of the Publishing Services, Canadian Government Publishing Centre, Ottawa, K1A 0S9.

TABLE OF CONTENTS

	Page
INTRODUCTION	1
Purpose	1
Contents	1
FUNDAMENTALS	3
Building Performance Requirements	3
Building Envelope	3
Building Envelope Quality	3
External Influences	4
Energy Management	4
Solar Gain	4
Energy for Heating	4
Reducing Energy for Heating	5
Energy for Cooling	5
Reducing Energy for Cooling	5
New Building Considerations	5
Financial Analysis	6
Heat Loss and Heat Gain Calculations	6
Heat Transmission	6
Infiltration	6
Estimating Heating Energy	8
Estimating Cooling Energy	8
Identifying Energy Management Opportunities	8
Walk Through Audit	9
Diagnostic Audit	9
Orientation	9
Walls	9
Foundation Walls	10
Windows	10
Doors	10
Roof	10
Floors	10
MATERIALS/SYSTEMS	11
Walls	11
Masonry Walls	11
Insulated Concrete Block Walls	12
Precast Concrete Walls	14
Insulated Metal Panel Walls	15
Brick Cavity Walls	17

Foundation Walls	18
Roofs	18
Built-Up Roof	18
Inverted Roof	20
Floors	21
Windows	21
Glazing	22
Frames	24
Shading Devices	24
Doors	24
Loading Docks	25
ENERGY MANAGEMENT OPPORTUNITIES	27
Housekeeping Opportunities	27
Low Cost Opportunities	27
Low Cost Worked Examples	28
1. Seal Windows and Add Weather-Stripping	28
2. Caulk Joints	28
3. Add Dock Seal	28
Retrofit Opportunities	28
Retrofit Worked Examples	28
1. Remove Siding/Add Insulation/Reinstall Siding	28
2. Add Insulated Metal Siding to Brickfaced Wall	29
3. Insulate Glazing Panels	29
4. Increase Wall Insulation	29
5. Add Roof Insulation	29
APPENDICES	
A Glossary of Terms	
B Tables	
C Common Conversions	
D Worksheets	
E Bibliography	

INTRODUCTION



The diversity of buildings within the Industrial, Commercial and Institutional sectors is substantial and includes manufacturing and processing plants, individual retail buildings, shopping complexes, hospitals, schools and general purpose offices. The size, shape and design standards vary according to the intended activities and budget.

Buildings provide protection from moisture and insulation against temperature extremes. The interior is heated and sometimes ventilated requiring special equipment and openings for the air intake and exhaust connections. Major heat transfer occurs by infiltration and exfiltration of air through and around openings in the building envelope.

Climate and topography vary widely within Canada. This range of natural conditions, combined with a variety of building functions, requires imagination and careful planning in building design. Consideration of the building envelope is mandatory for prudent energy management to reduce operating costs. Therefore, the potential for saving energy dollars can be substantial and should be seriously investigated.

Many buildings consume energy in a very wasteful manner. Often they were designed when energy was much less expensive, and sometimes the use is different than the basis of the original design. Minimal insulation resulted in energy waste, but when energy was relatively inexpensive it did not significantly affect operating costs. Older buildings, therefore, may be more wasteful of energy than buildings of newer design. At today's energy prices, operating costs can become prohibitive, and building practices must be modified accordingly.

This is not a building design manual, but an informative guide for owners and operators of buildings that are consuming more energy than necessary. Details are provided by which Industrial, Commercial or Institutional building envelopes can be modified to be more energy efficient. By studying the worked examples, a person without special training can implement measures to immediately improve the building energy performance. The individual owner, operator or maintenance person can do more to correct the cause of energy waste than is commonly recognized.

Purpose

The following summarizes the purpose of this module.

- Introduce the subject of architectural considerations as used in the Industrial, Commercial and Institutional sectors.
- Provide an awareness of potential energy and cost savings.
- Provide methods of establishing energy and cost savings.
- Provide a series of Worksheets, that can be used to perform calculations for existing and proposed systems, to determine the potential energy and cost savings.

Contents

The module is subdivided into the following sections.

- *Fundamentals* describes the basic theory of building envelope performance. The identification of opportunities for improved energy management with sample calculations and some observations on costs and benefits are also included.
- *Materials/Systems* contains a number of typical construction details for walls, roofs, doors, windows and loading docks, with suggestions for improvement.
- *Energy Management Opportunities* are described and supported by worked examples which show the energy and cost savings and simple payback calculations.
- The *Appendices* include a glossary of terms, information tables, conversion factors and worksheets for calculations.

FUNDAMENTALS



This section presents the energy-related requirements for the *building envelope*. It also provides suggestions for identifying Energy Management Opportunities during a walk through or diagnostic energy audit, sample energy calculations, and financial guidance.

Building Performance Requirements

A building envelope, comprised of walls, floor and roof, is the means by which the varying external conditions are separated from the internal conditions. Control of the following is necessary to achieve a lifetime of satisfactory building performance.

- Heat flow.
- Air movement.
- Entry of rain and snow.
- Vapor flow.
- Lighting.
- Solar energy.

Building Envelope

Building envelope materials have a significant impact on the amount of energy required to maintain an adequate environment within a structure. A *curtain wall*, composed primarily of glass and metal, is a major source of heat loss in winter, and heat gain in summer. A load-bearing wall consisting of masonry, insulation, and cladding, has substantially more thickness. This type of a wall has higher insulating capabilities, but a major problem results if moisture is allowed to penetrate and deteriorate the insulation.

Materials of different properties have different thermal conductivities of energy, and are compared on the basis of U-values and RSI-values. The thermal transmittance (U-value) identifies the ability of a material to conduct thermal energy. For example, aluminum has a higher U-value than wood and, therefore, a greater thermal conductivity capability. The RSI-value is the corresponding rate of thermal resistance (RSI-value = $1/U$ -value). Rigid insulation has a higher RSI-value than glass and, therefore, a greater thermal resistance or insulating capability. U-values and RSI-values are used in heat loss and heat gain calculations. Refer to Values of Thermal Resistance, Table 1.

Heat loss is most significant through the roof and walls of the building envelope. The floor is commonly constructed as a slab on grade, or as a built-up floor assembly above a basement or crawl space and is less critical.

The *roof* (e.g., precast concrete panels, metal decking) usually consists of a layer of insulation to reduce heat transmission, a waterproof membrane to prevent water leakage, and a layer of gravel to reduce damage to the membrane. In inverted roof construction, the waterproof membrane is applied first, followed by the insulation. Gravel is added on top to provide ballast to keep the insulation in place during high winds and rain. The application of insulation to the underside of a roof is often only practical in retrofit applications.

The *perimeter foundation walls* (e.g. concrete block, poured-in-place concrete) are moisture-proofed on the outside with asphalt below grade. Exterior insulation may be rigid type, whereas interior insulation is usually glass fiber batts.

The *concrete floor* has a polyethylene moisture barrier beneath it to prevent the entry of ground moisture. In some instances the slab may be insulated underneath and around the perimeter to reduce heat loss.

Building Envelope Quality

Building envelopes must be constructed and maintained to the highest standards of quality to reduce energy consumption and prevent structural damage. Today, many buildings can no longer be used for their original intended purpose because deterioration has occurred.

External Influences

Suitable *topography and landscaping* aids building envelope performance. Earth *berms* can be used to shield buildings in industrial parks from prevailing winds. Berming will also help modify the immediate temperature outside the building by acting as an insulator. Benefits can also be achieved with the use of trees and vegetation. Deciduous trees provide shade during hot summer months and, by shedding their leaves in winter, allow useful solar energy to reach the building.

The berming of an existing building will require the construction of a proper retaining wall that is reinforced, waterproofed and insulated. This is an expensive procedure, and the costs must be compared with potential benefits to determine economic viability.

In summation, the type and quality of the building envelope, as well as external influences must be considered to ensure lower maintenance and energy costs.

Energy Management

Building energy consumption is dependent on heating, cooling, lighting and ventilation requirements. This module is primarily concerned with the heating and cooling energy requirements that are influenced by the construction of the building envelope. Heating and cooling loads are also influenced by the building location, the time of day and the season.

Solar Gain

The heating effect of the sun's rays is called solar heat. *Solar gain* to a space is the result of this solar heat. In winter these gains are small, but help to reduce the overall building heating energy required. In summer the solar heat gain becomes significant and must be factored into the overall calculations to determine the cooling energy required.

The orientation (e.g. north, south), time of day, latitude and the building construction are key factors in determining the actual solar gain. Refer to Module 10, Heating, Ventilating and Air-Conditioning, for additional details about solar heat gains.

Energy for Heating

Heat loss through the building envelope during the winter months occurs by *heat transmission* through the building envelope and by *infiltration and exfiltration* of air through openings. Energy for heating is required to compensate for these losses. Other heat sources are often present to reduce the overall heating energy. Heat gains from people, lighting and process equipment often make a significant contribution.

Heat transmission through the building envelope occurs in three ways.

- *Conduction* is the heat flow through a solid material from the warmer to the cooler side of the envelope. This occurs through walls, roof/ceiling and floor slabs.
- *Convection* is the heat transfer caused by the motion of heated air from a warmer to a cooler surface. This occurs around windows and doors.
- *Radiation* is the transfer of heat by electromagnetic waves from a warmer to a cooler surface. It is transferred directly and is not affected by the temperature of the surrounding air.

Infiltration, the inward leakage of air, and *exfiltration*, the outward leakage of air, occur through poorly sealed window and door openings, construction joints, and ventilation and exhaust system openings by wind forces on the building. Exfiltration occurs when the interior building pressure is higher than the outside pressure. The air lost by exfiltration at one location is replaced by infiltration of outside air at another location in the building, or by a mechanical make-up air system.

Heat loss is affected by building height, vertical shafts for elevators, stairs, duct shafts, the number of windows and doors, plus the type of exterior cladding. Imperfections in the building envelope, as a result of poor construction quality and deterioration, further contribute to the amount of heat loss.

In tall buildings, air infiltration and exfiltration occur because of *stack effect*. Temperature differences between the interior and exterior create air density differences, which, in turn, cause a pressure differential that influences the infiltration rate. During the heating season, the warmer inside air rises and flows out of the building near the top. Air is replaced with colder outside air which enters the building near the base. The flow directions are reversed during the cooling season. The infiltration and exfiltration rates are less significant in the summer because of smaller temperature differences.

Reducing Energy for Heating

The energy required for heating can be reduced by preventing heat loss through the building envelope.

- *Insulation* conserves energy by reducing heat loss in winter. The practical thickness of insulation depends upon the difference between the required inside temperature and the ambient outside temperature. Additional insulation is more beneficial where there is a large temperature differential.
- A *vapor barrier* is installed within the building envelope to prevent *condensation* which can damage, if not destroy, the integrity of the building fabric and the insulation. Wet insulation often reduces the RSI-value of the wall construction by over 50 per cent.
- *Double or triple glazing* for windows will reduce heat loss because of a greater RSI-value. The improved insulating qualities permit the surface temperature of the glass inside the room to increase and help reduce the formation of condensation.
- *Revolving doors, vestibules, and automatic door closers* reduce infiltration and exfiltration by controlling air movement. Where possible, entrances should be oriented away from prevailing winds to reduce these losses. Door and window openings should be sealed with weather-stripping, while unwanted openings such as cracks should be caulked.
- *Reorganization of activities* within the building can reduce energy use. It is advantageous to locate a service space, such as a corridor, along the north side of the building and an activity space, such as an office area, along the south side. The north side can remain cool and act as a buffer for the south side which benefits from solar exposure. This means separating the building into zones based on specific heating and cooling requirements. Where the building is air-conditioned, care must be taken to ensure that heating savings are not offset by increased cooling costs. Unoccupied areas should not be heated or cooled more than is required for the protection of the building envelope and equipment.

Energy for Cooling

Energy for cooling is required because of heat gain. Significant gain occurs from the transmission of energy through the building envelope and from internal building processes (e.g. equipment, lighting and body heat loss). These gains may occur throughout the year. For additional details refer to Module 2, Lighting, and Module 10, Heating, Ventilating and Air-Conditioning.

The amount of solar energy received on vertical surfaces is a function of the building orientation. East and west facing walls receive maximum radiation in the morning and afternoon respectively. A wall facing south receives the greatest radiation about noon. East and west facing walls receive a greater amount of radiation than the south facing walls because the sun's rays are nearly perpendicular to these wall surfaces in the morning or afternoon, and hit the south facing surfaces at an angle at noon. Glazing provides the potential for allowing excessive solar heat gain if adequate preventive measures are not taken. This effect is compounded in wall areas containing a large percentage of glass. A similar concern exists with large flat roofs which can become major heat collectors in summer.

The objective of energy management is to save dollars by reducing the energy required for cooling, while maintaining an environment suitable for both process and staff.

Reducing Energy for Cooling

The energy required for cooling can be reduced by preventing solar radiation from reaching and penetrating the building envelope. The following techniques are particularly effective on the west and east sides of buildings.

- Reduce glass area.
- Provide shading with trees and vegetation.
- Add interior shading devices such as drapes and blinds.
- Add exterior shading devices such as overhangs, louvers, and awnings.
- Add insulation to reduce heat transmission.
- Add reflective films to existing clear glass to reduce solar gain.

Artificial lighting may have to be increased as windows are eliminated. Lighting provides supplemental heat in winter, but needs to be offset by air conditioning or ventilation in the summer.

New Building Considerations

New buildings can be oriented on the site and designed to optimize energy utilization. Use building materials with a high thermal resistance to minimize heat transmission. Consider multiple stories rather than one large single storey structure. Carefully locate windows to control heat losses and heat gains. Avoid glass in east and west exposures. Sealed double glazed window units should be considered as a minimum design criteria for most locations. Consider shading devices. Locate people away from exterior doors. Place corridors along outside walls that are cool in winter and warm in summer.

Financial Analysis

Improvements to an existing building will require some capital expenditure. Once the costs have been determined, the projected savings effected by the improvements can be compared against the costs in a simple payback calculation which gives an indication of the financial viability of the scheme. In some cases, the savings per year may be so large, and the capital cost so small, that the desirability of the project is indisputable. In other cases, a detailed analysis is needed to justify any expenditure.

Beyond simple payback, various methods for life cycle analysis can be employed in assessing a proposed retrofit program. Refer to the Financial Analysis Manual for methods of analyzing the financial performance of potential improvements.

Heat Loss and Heat Gain Calculations

This module specifically addresses the building enclosure calculations which are required to assess the value of an Energy Management Opportunity. For internal building heat loss/heat gain calculations refer to Module 10, Heating, Ventilating and Air-Conditioning.

Heat Transmission

Tables of *thermal resistance* are available for most materials of construction (Table 1) and are used to calculate the *thermal transmittance* of each building component. Comparisons can be made to deduce the thermal improvement of the building assembly if alterations are made to it.

The heat loss through a building component (wall, roof, door or window) is calculated by the equation:

$$Q = U \times A \times (T_2 - T_1)$$

Where, Q = Heat loss rate (W)

$$U = 1/RSI = \text{Thermal transmittance [W/(m}^2 \cdot \text{°C)]}$$

$$A = \text{Area (m}^2\text{)}$$

$$T_2 = \text{Temperature inside (°C)}$$

$$T_1 = \text{Temperature outside (°C)}$$

For walls and windows, the inside temperature is the average room temperature. For roofs, the inside temperature is the average temperature at the ceiling. The outside temperature is the summer or winter design temperature for the geographical location as found in the National Building Code (Table 2). Heat transmitted through basement walls and floors is negligible and can be ignored.

Infiltration

Infiltration heat losses can be arbitrarily divided into two categories, infiltration through cracks, and infiltration through large openings. Typically, cracks are long narrow openings with a width less than 10 mm. In both cases, infiltration is calculated using the fundamental equation:

$$Q = 1.232 \times fa \times (T_2 - T_1)$$

Where, Q = Heat loss rate (W)

$$fa = \text{Flow rate of infiltration air (L/s)}$$

$$T_2 = \text{Temperature inside (°C)}$$

$$T_1 = \text{Temperature outside (°C)}$$

1.232 = A factor which accounts for conversion to common units

The term f_a is calculated differently for cracks and large openings. The following notes are applicable to the general equation.

- The heat loss equation is applicable to infiltration and exfiltration.
- When T_1 is greater than T_2 , Q becomes negative and represents a heat gain.
- Infiltration rates for winter are approximately double the summer rates owing to the higher seasonal wind velocities.
- Infiltration caused by stack effect should be considered for buildings over 30 metres high. This type of calculation should be carried out by a design specialist.

Heat loss caused by infiltration through cracks around doors and windows is calculated by one of two techniques, area method or crack method.

Crack method infiltration rates, per meter of crack (I), are provided in Table 3 from which the overall infiltration rate f_a , can be calculated.

$$f_a = I \times L$$

Where, f_a = Infiltration rate (L/s)

I = Infiltration rate per meter of crack [L/(s·m)]

L = Length of crack (m)

Infiltration rate tables based on area are available in ASHRAE Handbooks and in the Carrier System Design Manual and will not be presented in this module. (See Bibliography in Appendix E).

The infiltration resulting from wind blowing through a large opening is calculated by the following equation.

$$f_a = E_o \times A \times V \times 1000$$

Where, f_a = Infiltration rate (L/s)

E_o = Effectiveness of opening expressed as a unitless factor (0.60 maximum for perpendicular winds, and 0.25 minimum for diagonal winds as determined by experiment). For worked examples use the average value of 0.40.

A = Area of opening (m^2)

V = Average seasonal wind velocity, (available from the local weather office), divided by two (m/s). The velocity value is divided by two, to account for the actual effect of the wind on infiltration. When the velocity is unknown a value of 1.7 m/s can be used.

The equation then becomes:

$$\begin{aligned} f_a &= 0.40 \times A \times 1.7 \times 1000 \\ &= 680 \times A \end{aligned}$$

The interval that a door or large size area is open must also be considered when calculating the annual energy loss. The “fraction of operational time” can be calculated.

$$OT = \frac{t}{168}$$

Where, OT = fraction of operational time expressed as a decimal

168 = total hours available per week

t = length of time door or area is open per week (h)

Estimating Heating Energy

Estimating the total heating energy requirement and the cost requires several calculations. In simplified form:

FOR NATURAL GAS HEATING

$$AG = \frac{2.95 \times Cf \times Q \times DDh}{(T_2 - T_1)}$$

Where, AG = Estimated annual cost of gas (\$)

Cf = Unit cost of fuel (gas, \$/m³)

Q = Heat loss (kW)

DDh = Degree days below 18°C

T₂ = Average temperature inside (°C)

T₁ = Design temperature outside (°C)

2.95 = A factor covering the conversion of units

FOR OIL HEATING

$$AO = \frac{2.73 \times Cf \times Q \times DDh}{(T_2 - T_1)}$$

Where, AO = Estimated annual cost of oil (\$)

Cf = Cost of fuel (oil, \$/L)

2.73 = A factor covering the conversion of units

FOR ELECTRIC HEATING

$$AE = \frac{16.8 \times Ce \times Q \times DDh}{(T_2 - T_1)}$$

Where, AE = Estimated annual cost of electricity (\$)

Ce = Electricity cost (\$/kWh)

16.8 = A factor covering the conversion of units

Estimating Cooling Energy

Improvements made to reduce heating energy usually have the secondary effect of reducing cooling energy. Detailed calculations by a specialist are required to assess solar contributions for both summer and winter.

An Energy Management Opportunity becomes more attractive when the energy saved by reducing the mechanical refrigeration required is added to the heating savings.

Identifying Energy Management Opportunities

Existing building conditions must be understood before all energy management opportunities can be identified. This can be accomplished by walk through and diagnostic audits. The first audit is a visual inspection of the facility, whereas the second is an analytical investigation involving data accumulation and mathematical calculations to determine potential energy reductions. It will be beneficial to enlist the aid of employees to obtain their interpretation of the building operation and how energy may be saved.

Walk Through Audit

A *walk through audit* can identify problems such as inadequately sealed door and window openings, deteriorating materials, poor quality building components, the lack of insulation, and repair requirements. This audit is usually more meaningful if a “fresh pair of eyes” generally familiar with energy management is involved.

Many Energy Management Opportunities identified in a walk through audit can be implemented immediately to upgrade the building at low cost to the building owner. They do not require a specialist’s input and can be implemented by maintenance and operating staff.

- *Walls* perform a major role with respect to heat transmission and the infiltration of air. They are important to the satisfactory performance of the building and to the efficient use of energy. While it is unlikely that the exact wall composition can be determined by a walk through audit, visible damage will be most evident in the interior and exterior finishes. Any deterioration should be repaired as it will be a source of heat loss.
- Masonry or poured concrete *foundation walls* are a less significant source of heat loss than upper walls. In basements or crawl spaces, perimeter walls may be insulated on the exterior with rigid insulation, or on the interior with batt insulation. Any insulation which has sustained moisture or other damage should be replaced.
- The *roof* is potentially a major source of heat loss in winter and heat gain in summer. The melting of snow on parts of the roof can be visual evidence of an excessive heat loss problem. Excessive heat gain, on the other hand, may be identified from melted asphalt penetrating the roof and passing through the wood decking to the space below.
- A *floor* suspended over an unheated crawl space should be checked for insulation. Floor assemblies over occupied basements do not require insulation.
- *Window and door frames* are constructed of wood, steel or aluminum. Wood frames provide good insulation, but they shrink and swell with changes in moisture content, and require substantial maintenance. Metal frames are dimensionally stable but poor insulators. Caulking reduces infiltration between the frame and the door or window. Frequency of *opening* significantly affects energy use.
- A *vestibule* is an enclosed passage between the outer door and the interior of the building. Its purpose is to prevent air from passing directly between the outside and inside. By having a self-contained air circulation system, a vestibule alters the temperature of incoming air, and acts as a pressure buffer between the outside and inside environments. Vestibules are recommended at all building entrances and exits, and are particularly important for those openings that face the prevailing wind. Vestibules should be checked for adequate weather-stripping and properly functioning doors and door closers.
- *Loading docks* without adequate weatherproofing can be a source of excessive air infiltration and heat loss. Energy costs can be reduced by adding weather-stripping around an overhead door and by installing a cushioned dock seal or shelter. Refer to Module 17, Materials Handling and On-Site Transportation Equipment.

Diagnostic Audit

A *diagnostic audit* requires detailed analysis of the building envelope in order to estimate the heat loss. Drawings and specifications of the building are useful sources of information. It is preferable to use as-built drawings, which indicate the final arrangement of the building after construction was completed. If none are available, *test cuts* through the wall and roof may be required to establish the actual composition.

Thermography is another method used to analyze the condition of the building enclosure. Specialists use infrared photography to detect areas of excessive heat transmission through walls and roofs. Potential problem areas are shown, but the components used in the building envelope are not identified.

Orientation

External effects on the building such as wind and sun, are a function of building orientation. Assessment generally requires a specialist’s input.

Walls

To perform a diagnostic audit, it is necessary to determine the exact composition of the wall from as-built drawings or by making test cuts through the wall. It is then possible to calculate the effects of the existing construction on energy consumption by following the examples in this module and completing the worksheets.

- Compute the thermal resistance (RSI-value) of the wall using the heat flow coefficients of the materials (Table 1).
- Establish the temperature gradient through the construction. For each material component, there is a temperature change which is proportional to the RSI-value of the particular material. The total temperature difference between inside and outside corresponds to the total RSI-value of the assembly. The figures in the "Materials/Systems" section show temperature gradients for a number of construction arrangements.
- Determine the temperature gradient to establish the location of the *dew point* condition, i.e., the temperature at which condensation will form.
- Determine the building envelope heat loss and heat gain.
- Calculate dollar savings by following the examples for various improvement alternatives.

Foundation Walls

If basement walls are finished, it may not be possible to visually determine the presence or lack of insulation. By dismantling a small section of the interior wall, the insulation details can be established. Heat loss calculations can be performed and repeated for alternative improvement possibilities.

Windows

Calculations can be performed to evaluate the energy loss of existing windows. Once the calculations have been done, it will be possible to establish the following.

- Need to replace existing glass or windows.
- Type of glass or windows to recommend.
- Requirement for internal and external shading devices.
- Need for weather-stripping or storm windows.

Doors

Infiltration of air around doors must be calculated to assess whether an opportunity exists to save energy dollars. After completing the calculations, the following measures can be considered to reduce the energy loss.

- Install storm doors.
- Replace or add weather-stripping.
- Replace existing swinging entrance doors in high traffic areas with revolving doors.
- Install a vestibule or dock seal.

Roof

Heat loss, solar heat gain and water leakage must be considered for a roof. Increased heat loss results from warm air rising and increasing the temperature differential between inside and outside. Solar heat gain occurs during the summer through the process of radiation, particularly with large, predominantly flat roofs. Water leakage, resulting from inadequate waterproofing or damaged construction materials, will reduce the thermal resistance value of the insulation. Several steps can be taken to assess a roof.

- Retain a roofer to establish the roof composition by making test cuts, if as-built drawings are not available.
- Establish the thermal resistance value of the roof.
- Calculate heat loss and heat gain.

Floors

Heat transfer through slab-on-grade floors is minimal and detailed analysis is not practical.

MATERIALS SYSTEMS

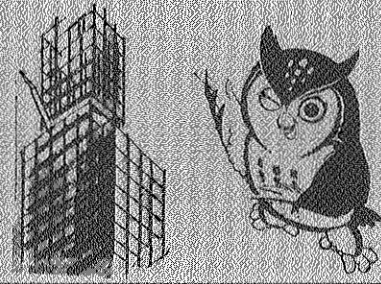

This section describes the building materials commonly used to create a building envelope system.

Walls

The following components are used in the construction of exterior walls.

- An *interior finish* (e.g., gypsum board, metal lath, plaster) selected for utility and appearance.
- A *vapor barrier* (e.g., polyethylene film or aluminum foil) to control vapor flow. This prevents interior moisture from entering the wall where it could condense and reduce the effectiveness of the insulation. The vapor barrier must be located on the warm side of the insulation to prevent condensation.
- *Insulation* (e.g., expanded polystyrene panels or glass fibre batts) to control heat flow is a major component of the wall thermal resistance, reducing heat loss in winter and heat gain in summer.
- *Structural infill* (e.g., concrete block, studs) to support the insulation, hold the vapor barrier in place, absorb and transmit wind loads to the frame and, sometimes, support the cladding.
- An *air barrier* (e.g., asphalt mix, sheathing panels and building paper) to control air movement through the envelope.
- A *vented air space* to allow dissipation of unwanted water vapor. It should be located on the cold side of the building wall.
- *Cladding* (e.g., brick veneer, metal siding, precast panels) to shed water and provide a finished appearance to the building exterior.

Walls of many industrial and small general purpose buildings consist of a single skin of concrete blocks or precast panels. Masonry units may contain some interior cavity insulation, but the overall thermal resistance is low. *Air films* on the building interior and exterior surfaces have the effect of a thin insulating layer, because friction between the air and surface of the wall keeps the air essentially motionless. The interior finish of an office provides additional thermal resistance plus continuity against air leakage.

Walls can be upgraded by adding insulation and a vapor barrier to the inside or outside of the building skin. The objective is to increase the thermal resistance of the assembly, reduce air migration from inside to outside, or vice versa, minimize thermal bridging, and prevent condensation. The addition of insulation on the exterior of the existing assembly is the preferable procedure, since the dew point and freezing point are pushed to the outside of the new vapor barrier beyond the structural portion of the wall. This effect can be observed in the temperature gradients of the following figures.

Masonry Walls

Construction - Concrete block, 200 mm thick, no insulation, ineffective vapor barrier (Figure 1). For the chosen conditions, condensation and freezing occur within the structural wall. Rapid deterioration of the wall (e.g. efflorescence and mortar breakdown) can result.

Improvement - Add insulation, vapor barrier and new skin to the exterior of the masonry wall (Figure 2). With this improvement the dew point is moved outside the new vapor barrier preventing condensation within the wall.

This method is particularly appropriate if the existing wall is damaged or eroded. The masonry wall is used to support a system of furring channels, clips, or rigid insulation of appropriate thickness with mechanical or spot laminations. The installation of a vapor barrier requires treatment to the complete wall with an adhesive type vapor seal or a film of foil or polyethylene. The exterior skin is often prefinished corrugated metal but can also be prefinished asbestos, flat metal panels, glass fiber systems or wood.

Advantages - The building appearance can be improved. Also, the addition of insulation and a vapor barrier keeps the structure close to the relatively constant interior temperature. This feature reduces expansion and contraction between walls and roof to minimize thermal stress in the structure and reduces heat loss and heat gain.

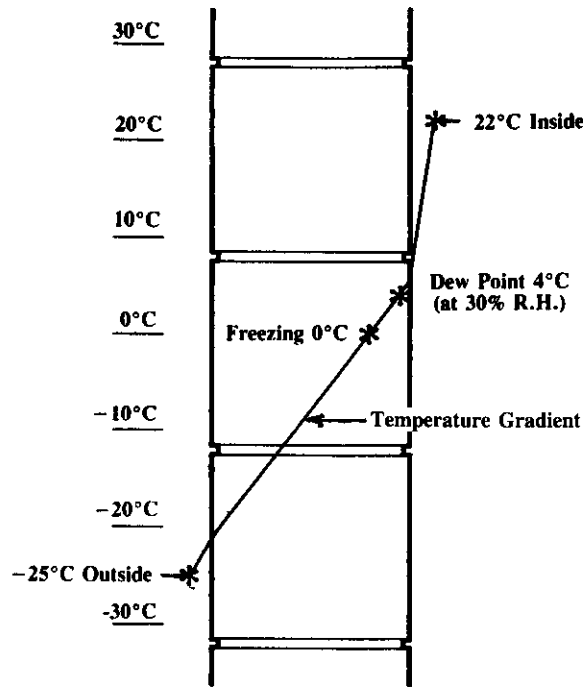

	RSI-value
Inside Air Film	0.120
200 mm Concrete Block	0.195
Outside Air Film	0.030
RSI	0.345

$$U = \frac{1}{RSI} = \frac{1}{0.345} = 2.90$$

Concrete Block Wall
Figure 1

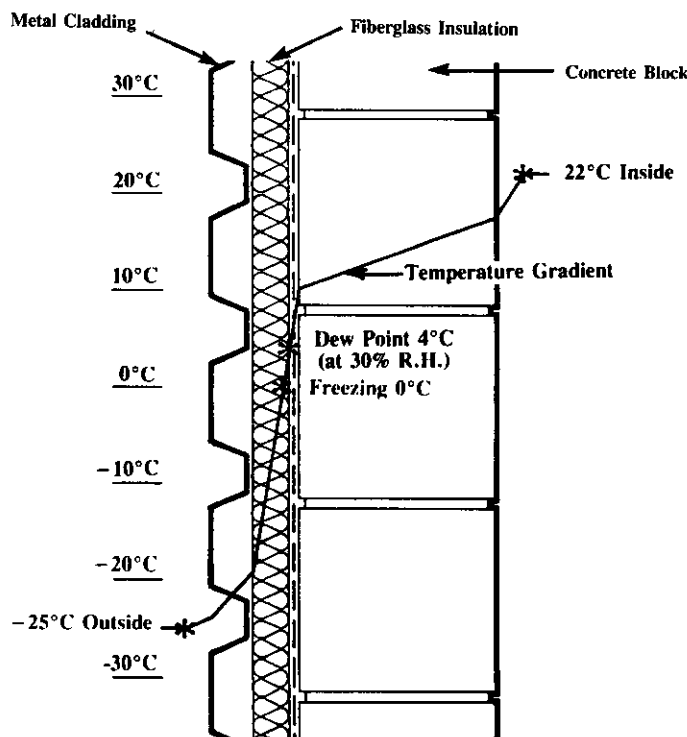

	RSI-value
Inside Air Film	0.120
200 mm Concrete Block	0.195
Vapor Barrier	Neg.
38 mm Fiberglass Insulation	0.790
Metal Cladding	0.123
Outside Air Film	0.030
RSI	1.258

$$U = \frac{1}{1.258} = 0.79$$

Concrete Block Wall
(Improvement)
Figure 2

Insulated Concrete Block Walls

Construction - Concrete block, 200 mm thick with vermiculite insulation fill (Figure 3). Condensation and freezing will occur within the insulation in the wall cavity and contribute to breakdown of the wall.

Improvement - Add insulation, a vapor barrier and drywall to the interior surface (Figure 4). The temperature gradient in this figure shows the dew point and the freezing point close to the outer surface of the insulation.

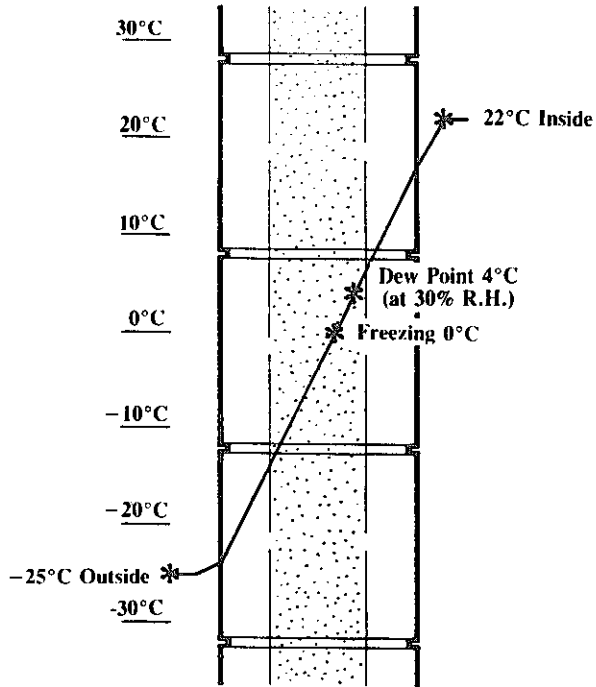

	RSI-value
Inside Air Film	0.120
200 mm Concrete Block — with Vermiculite	1.000
Outside Air Film	0.030
	RSI = 1.150

$$U = \frac{1}{1.150} = 0.87$$

Insulated Concrete Block Wall
Figure 3

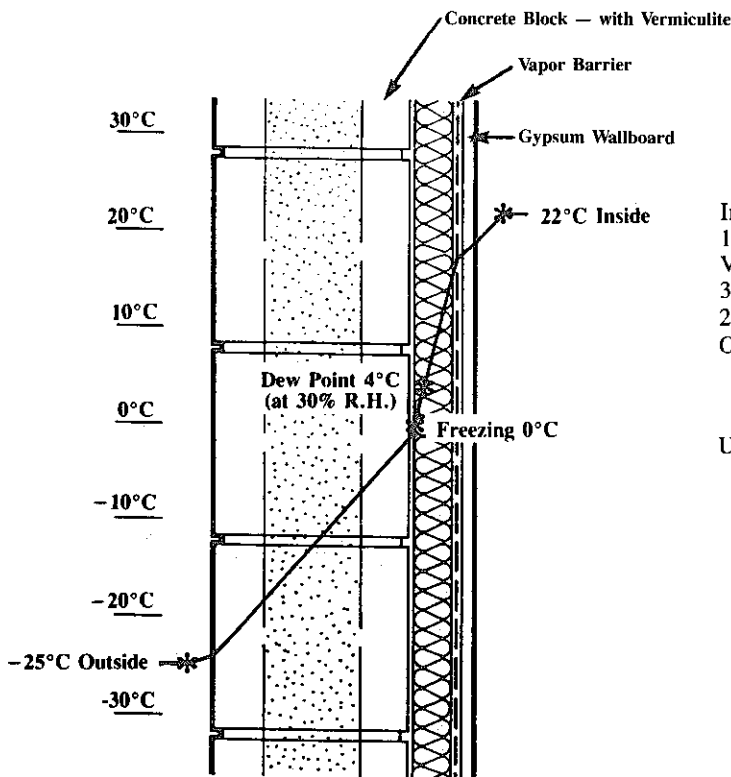

	RSI-value
Inside Air Film	0.120
12 mm Gypsum Wallboard (GWB)	0.074
Vapor Barrier	Neg.
38 mm Fiberglass Insulation	0.790
200 mm Concrete Block — with Vermiculite	1.000
Outside Air Film	0.030
	RSI = 2.014

$$U = \frac{1}{2.014} = 0.50$$

**Insulated Concrete Block Wall
(Improvement)**
Figure 4

In this application it is important to ensure that the vapor barrier is continuous on the inside face of the insulation. *Furring* can be applied directly to the inside surface of structural masonry walls, even though cold bridges result from the direct connection of the cold masonry wall with the inside wall surface. Furring members are fully supported and can be small. Deeper members provide a contained air space for additional insulating value. A wide choice of insulation materials is available for this application.

Structural studs are sometimes used in the construction of a new interior wall. Insulation must fill all stud spaces, eliminating gaps and the flow of air through the wall. This procedure provides a separation from the masonry wall, but is costly, particularly with high walls.

Precast Concrete Walls

Construction - Single skin precast panels. Some panels may have insulation in the cavities while older walls may have a full web of concrete which results in thermal bridging (Figure 5). New buildings are often constructed with small metal ties that minimize thermal bridging (Figure 6). Condensation and freezing can occur within the panels if the vapor barrier is not intact.

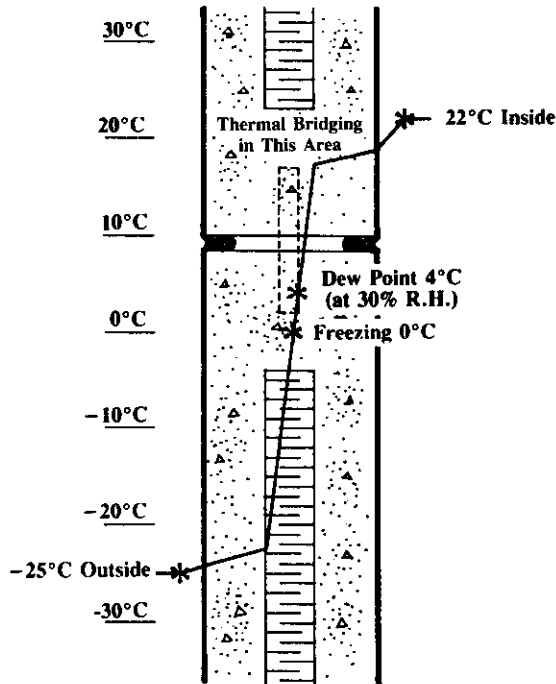

	RSI-value
Inside Air Film	0.120
62 mm Precast (P.C.) Concrete	0.059
50 mm Urethane Insulation	1.541
62 mm P.C. Concrete	0.059
Outside Air Film	0.030
RSI =	1.809

$$U = \frac{1}{1.809} = 0.55$$

Precast Concrete Wall
(With Thermal Bridging)
Figure 5

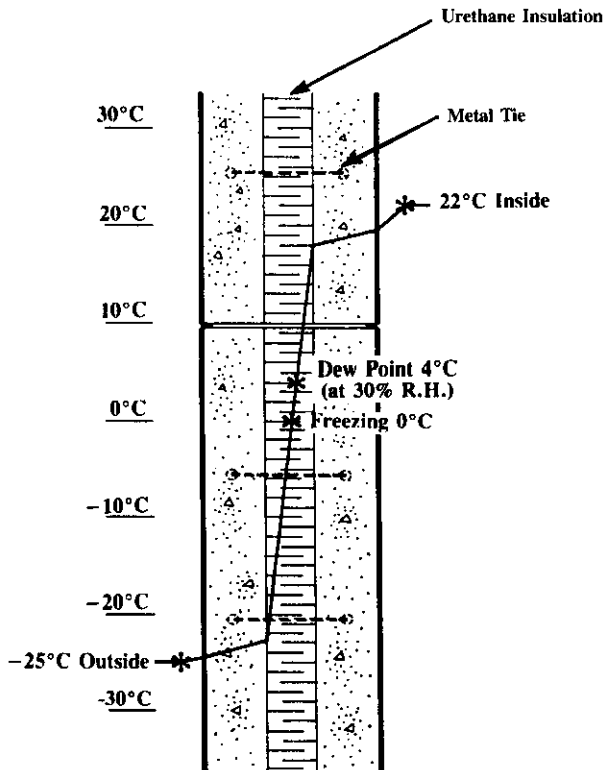

	RSI-value
Inside Air Film	0.120
62 mm P.C. Concrete	0.081
50 mm Urethane Insulation	2.100
62 mm P.C. Concrete	0.081
Outside Air Film	0.030
RSI =	2.412

$$U = \frac{1}{2.412} = 0.41$$

Precast Concrete Wall
Figure 6

Improvement - When the exterior surface is intact, an interior modification is appropriate (Figure 7). Rigid insulation is laminated to the interior surface of the precast panels. Gypsum wallboard panels, with foil backing to provide a vapor barrier, are then glued to the insulation. It is important to seal all the joints in this membrane to prevent water vapor migration toward the exterior where it will be trapped in the wall. A thorough coat of paint on the inside can reduce vapor movement.

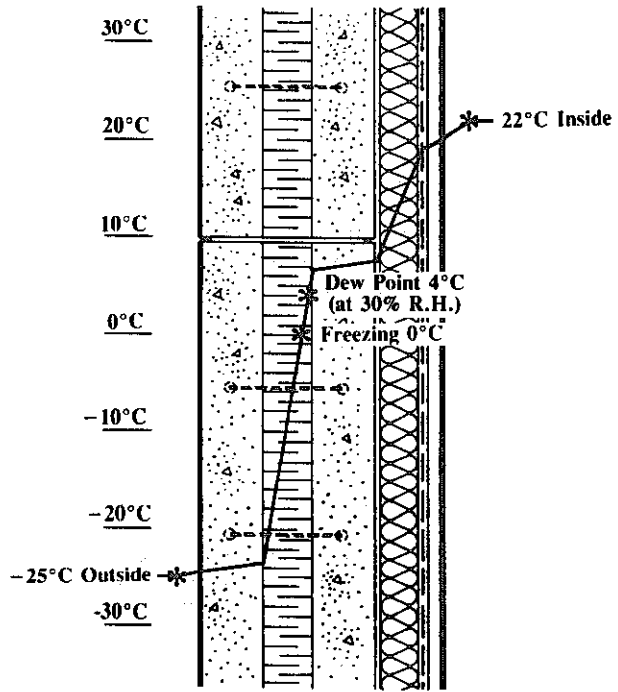

	RSI-value
Inside Air Film	0.120
12 mm GWB	0.074
Vapor Barrier	Neg.
38 mm Fiberglass Insulation	0.790
62 mm P.C. Concrete	0.081
50 mm Urethane Insulation	2.100
62 mm P.C. Concrete	0.081
Outside Air Film	0.030
RSI =	3.276

$$U = \frac{1}{3.276} = 0.31$$

Precast Concrete Wall (Improvement)
Figure 7

Insulated Metal Panel Walls

Construction - Exterior metal siding, cavity insulation and an interior metal liner (Figure 8). The exterior siding provides rainscreen protection for the insulation. The system relies on an interior metal liner sheet for the vapor barrier. The temperature gradient illustrates the importance of maintaining a continuous vapor barrier.

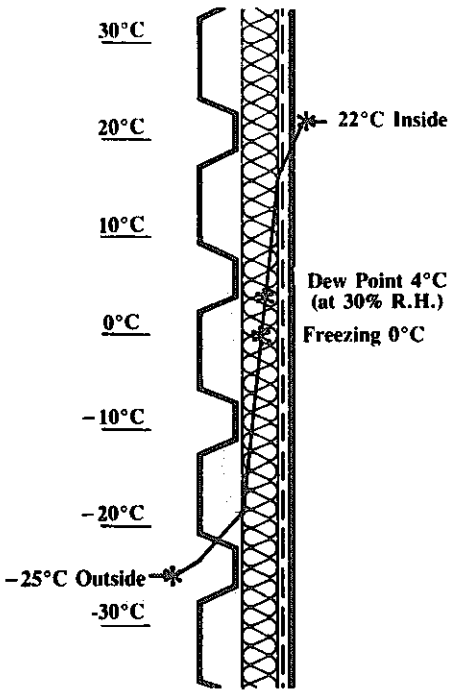

	RSI-value
Inside Air Film	0.120
Metal Liner Vapor Barrier	Neg.
38 mm Fiberglass Insulation	0.790
Metal Cladding	0.123
Outside Air Film	0.030
RSI =	1.063

$$U = \frac{1}{1.063} = 0.94$$

Insulated Metal Panel Wall
Figure 8

Improvement to Exterior - Increase insulation thickness (Figure 9). The process requires the removal of the existing skin and the addition of extension clips or channels. Once the extra insulation has been added, the siding is reinstalled. New flashings and fittings may be required.

Advantages - Insulating properties can be improved without disruption of interior operations. The major cost is labor because cladding materials are reused.

Disadvantages - This system relies entirely on the existing vapor barrier which is provided by the interior metal liner sheet and a sealant at the overlapping joints. The vapor barrier may not have been continuous and the joints could have opened because of air pressure and movement in the building skin. Joints should be thoroughly recaulked.

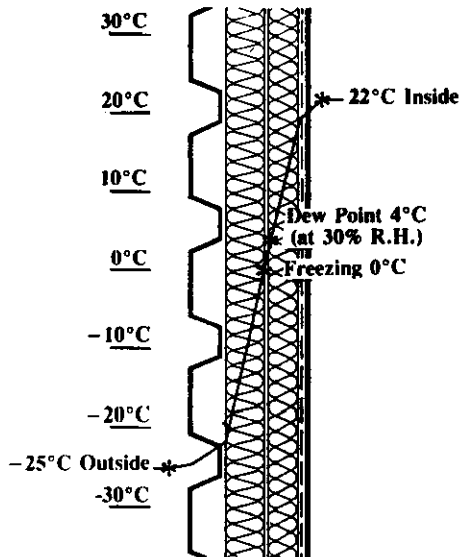

	RSI-value
Inside Air Film	0.120
Metal Liner Vapor Barrier	Neg.
38 mm Fiberglass Insulation	0.790
50 mm Fiberglass Insulation	1.040
Metal Cladding	0.123
Outside Air Film	0.030
RSI =	2.103

$$U = \frac{1}{2.103} = 0.48$$

Insulated Metal Panel Wall
(Improvement to Exterior)
Figure 9

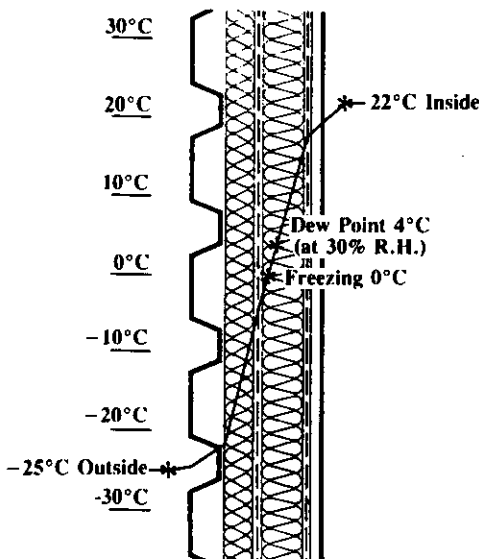

	RSI-value
Inside Air Film	0.120
12 mm GWB	0.074
Vapor Barrier	Neg.
50 mm Fiberglass Insulation	1.040
Metal Liner/Vapor Barrier	Neg.
38 mm Fiberglass Insulation	0.790
Metal Cladding	0.123
Outside Air Film	0.030
RSI =	2.177

$$U = \frac{1}{2.177} = 0.46$$

Insulated Metal Panel Wall
(Improvement to Interior)
Figure 10

Improvement to Interior - Add insulation and drywall to the inside of the existing wall (Figure 10). Furring is required if mineral fiber insulation is used. Alternatively, rigid board insulation can be glued directly to the metal liner sheet. A vapor barrier is required inside the new insulation, followed by an interior finish such as gypsum board, wood or plywood. Rigid insulation is highly flammable and must be covered with gypsum wallboard for safety and to meet the requirements of the National Building Code.

Advantages - New insulation can be installed from the inside, independent of weather and season, without disturbing the wall system. A full range of insulation materials are available and a new interior finish is an added benefit.

Disadvantages - The new vapor barrier is extremely important since any vapor passing through it will be trapped in the wall. If electrical or other services are installed care must be taken to maintain the barrier. Existing structural steel members and electrical wiring present problems for new framing.

Brick Cavity Walls

Construction - Concrete block and brick veneer with a cavity and possible insulation in-between (Figure 11). If the vapor barrier is lacking, or is not continuous, moisture will condense and freeze within the cavity.

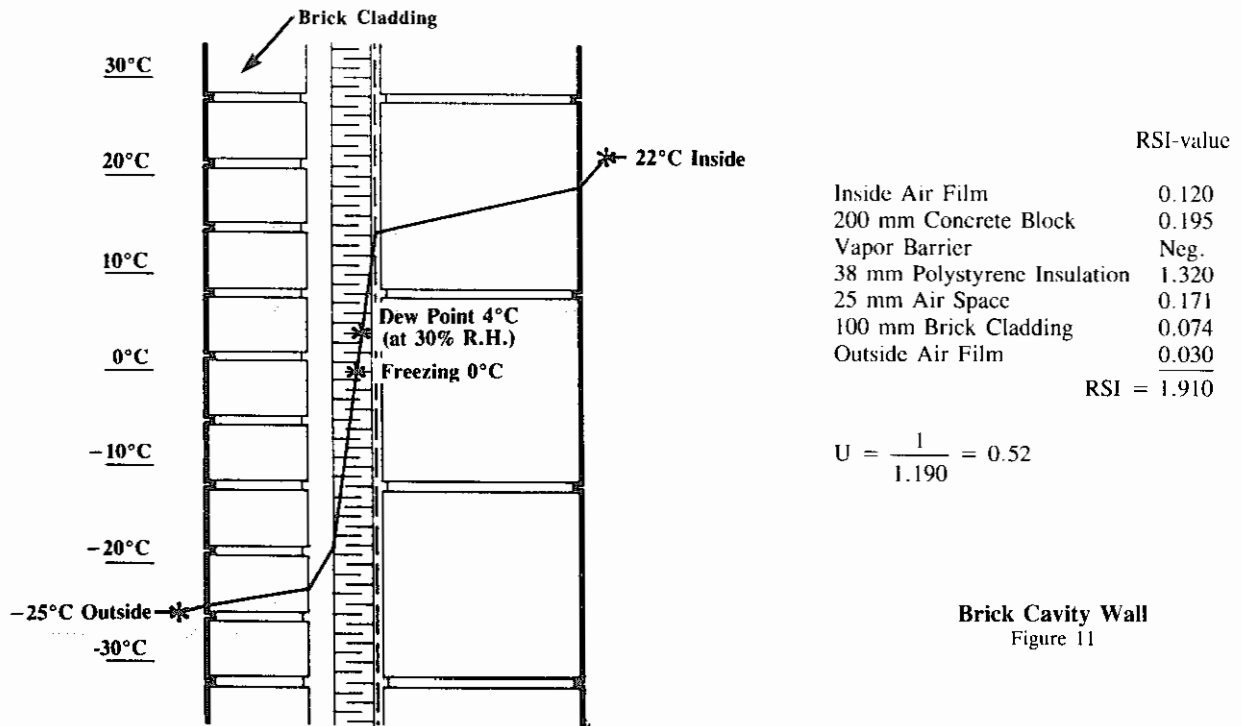

Brick Cavity Wall
Figure 11

Improvement - Because of the existing brick finish, only interior improvement is practical (Figure 12). Add batt insulation between strapping or glue rigid insulation panels to the concrete block surface. Apply a new continuous vapor barrier followed by gypsum wallboard or other interior finish.

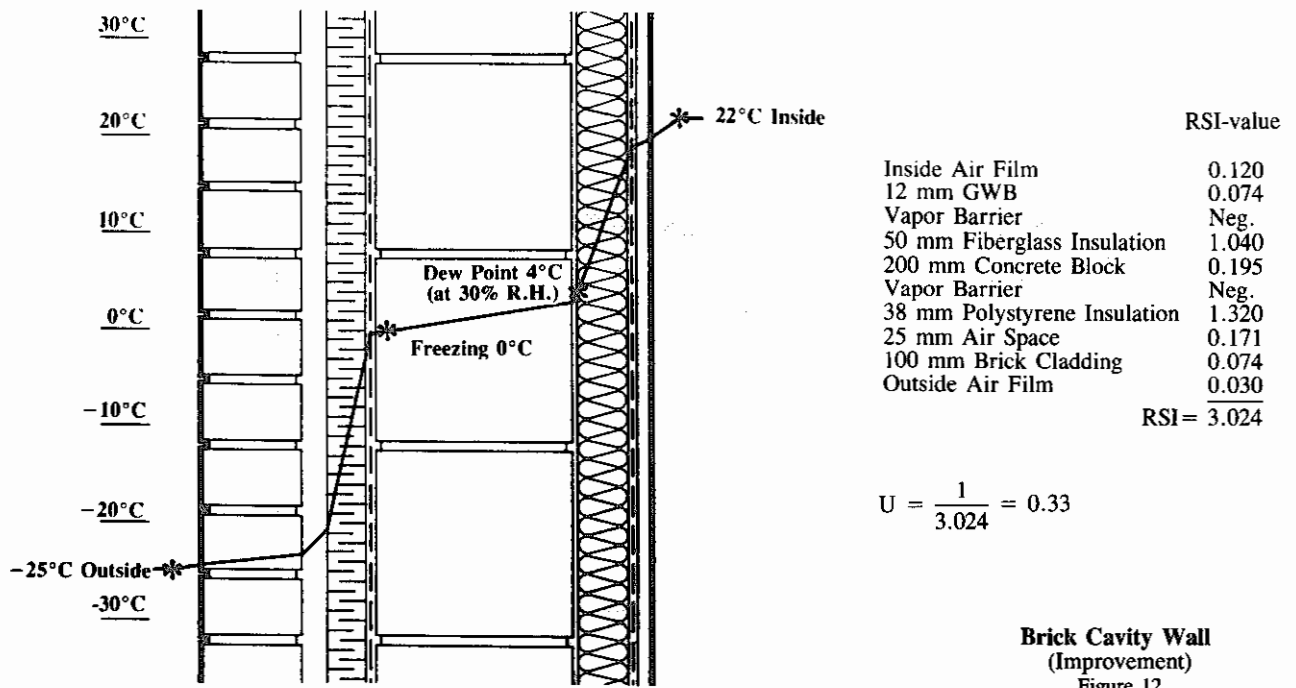

Brick Cavity Wall
(Improvement)
Figure 12

Advantage - Installation can be done at any time of year.

Disadvantages - Addition of insulation can relocate the dew point to inside the structural wall. Serious damage may result if the vapor barrier is not properly installed. Also, the new interior finish may be less durable than the existing concrete block.

Foundation Walls

Foundation walls may have insulation added to the exterior or interior surface similar to the described building walls. A basement wall is easily improved with furring and batt insulation (Figure 4). The vapor barrier is extremely important. If a crawl space is accessible, it can also be insulated by this method. If the crawl space is inaccessible, rigid insulation can be added only to the exterior of the foundation walls. The depth of the insulation required below grade should be determined by a specialist that is knowledgeable of winter temperatures and frost depths. Incorrect installation may result in frost damage.

Roofs

The following components are used in the construction of roof assemblies.

- A *waterproof membrane* (e.g., asphalt with gravel cover, single-ply neoprene) to prevent water entry.
- *Rigid type insulation* (e.g., urethane, polystyrene, glass fiber) to control heat flow.
- A *vapor barrier* (e.g. bituminous sheet felt) on the under side of the insulation to perform the same function as described for the walls.
- A *structural roof deck* (e.g., metal pan, concrete, factory wood deck) to provide continuous support for the waterproof membrane, insulation and vapor barrier.
- *Major structural members* (e.g. metal trusses, concrete or wood beams) to support the roof deck and suspended loads.
- A *ceiling* (e.g., gypsum board, lath and plaster, T-bar and acoustical tile) attached to the underside of the structure for acoustical or finishing purposes.

Exterior roofing improvements are usually the most practical. Disadvantages of interior improvements include occupant and process disruption and incomplete sealing of vapor barrier because of structural members and building services.

Built-Up Roof

Construction — A vapor barrier is placed over the structural deck. Insulation in the form of fiberboard, polystyrene or rigid fiberglass is added, followed by layers of roofing felts bonded and coated with hot-mopped bitumen. Pea gravel provides a topping to protect the felts and asphalt from the sun's ultraviolet rays (Figure 13). The vapor barrier is more critical for roofing than walls. With the concentration of warm vapor-laden air at the ceiling, any leaks in the vapor barrier will cause problems. Escaping vapor will condense and freeze under the roofing membrane.

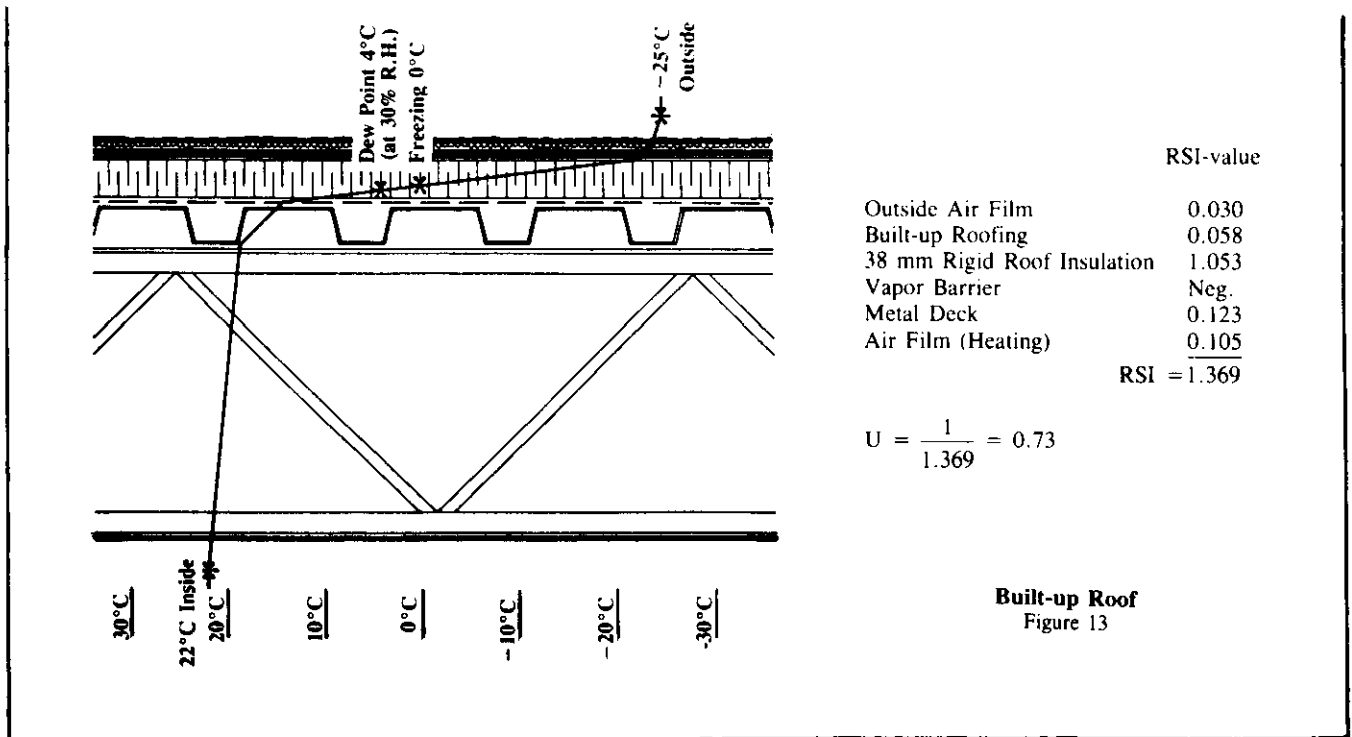

Improvement - Alternative A - The degree to which the roof must be stripped depends on the age, condition and type of insulation. An expert may be required to inspect and test the roof. The improvement could involve the removal of the stone cover and loose asphalt and felts, reuse of the vapor barrier, and the building of the new roof on top of the remaining materials (Figure 14). The capital cost of this improvement is equivalent to complete reroofing and must be evaluated against the expected remaining life of the existing roof. The amount of insulation which can be added may be limited by the heights of existing copings and flashings at the perimeter, and equipment on the roof. New flashings may be required if thickness is increased.

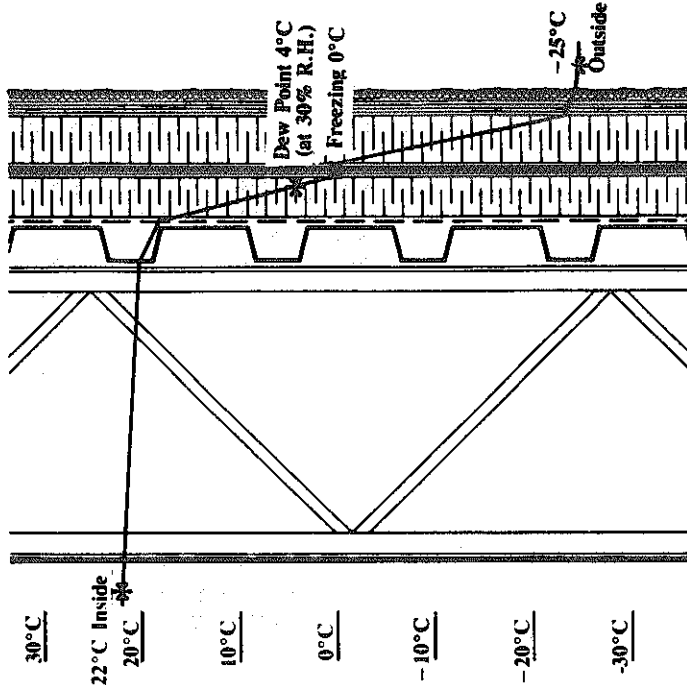

	RSI-value
Outside Air Film	0.030
Built-up Roofing	0.058
50 mm Rigid Roof Insulation	1.385
Built-up Roofing	0.058
38 mm Rigid Roof Insulation	1.053
Vapor Barrier	Neg.
Metal Deck	0.123
Air Film (Heating)	0.105
	RSI = 2.812

$$U = \frac{1}{2.812} = 0.36$$

Built-up Roof
(Improvement - Alternative A)
Figure 14

Improvement - Alternative B - Scrape off the existing gravel and place a new layer of rigid insulation on the membrane. Add sufficient gravel ballast to compensate for the flotation effect of the added insulation (Figure 15). Care must be taken not to perforate the existing roof membrane, since no new membrane is installed. The addition of gravel ballast is significant and the effects of the additional weight must be considered by a structural engineer.

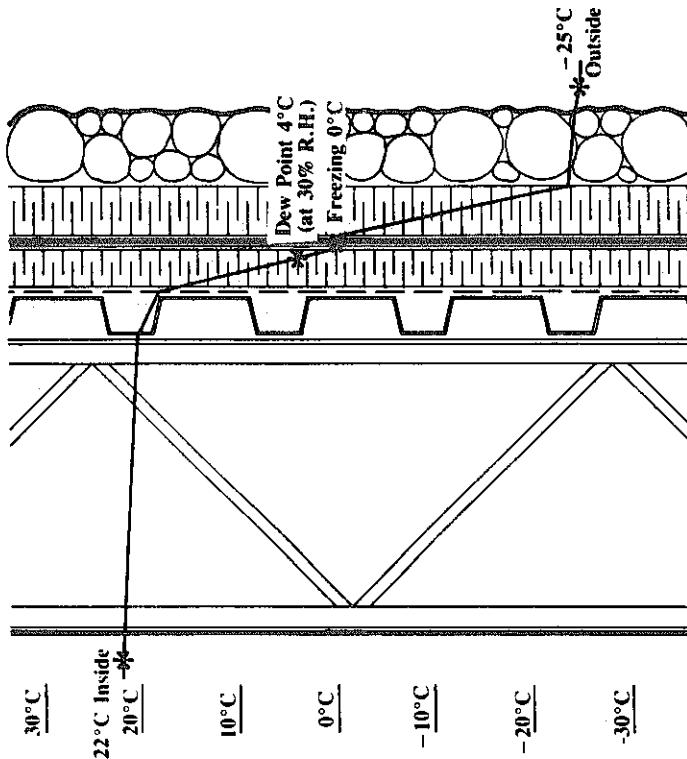

	RSI-value
Outside Air Film	0.030
76 mm Gravel Ballast	0.046
50 mm Rigid Roof Insulation	1.385
Built-up Roofing	0.058
38 mm Rigid Roof Insulation	1.053
Vapor Barrier	Neg.
Metal Deck	0.123
Air Film (Heating)	0.105
	RSI = 2.800

$$U = \frac{1}{2.800} = 0.36$$

Built-up Roof
(Improvement - Alternative B)
Figure 15

Improvement - Alternative C - Scrape off loose gravel and asphalt. Spray on a layer of urethane foam insulation and follow with an exterior sealant of silicone of equal RSI-value (Figure 16). This improvement is a patented system and must be put in place by a specialist.

Advantage - The insulation in Alternatives A, B or C can easily be installed in various thicknesses to accommodate drainage, existing flashings and fittings.

Disadvantages - Alternative C is a recent development and not time-tested. Few installations have been in place for ten years. The application can be costly since it is a patented system with few installers. The silicone skin is susceptible to damage by birds and rooftop maintenance personnel. The urethane foam breaks down in sunlight once the silicone skin is damaged and there may be unknown perforations in the vapor barrier.

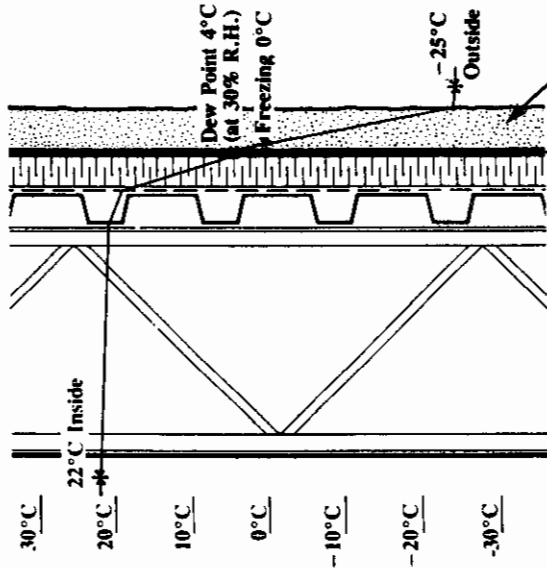

	RSI-value
Urethane Foam Insulation	
Outside Air Film	0.030
50 mm Urethane Foam Insulation	2.100
Built-up Roofing	0.058
38 mm Rigid Roof Insulation	1.053
Vapor Barrier	Neg.
Metal Deck	0.123
Air Film (Heating)	0.105
RSI =	3.469

$$U = \frac{1}{3.469} = 0.29$$

Built-up Roof
(Improvement - Alternative C)
Figure 16

Inverted Roof

Construction - Insulation is provided above the waterproof membrane (Figure 17). The membrane is not affected by temperature extremes, ultraviolet light or other sources of damage. The vapor barrier and the roofing membrane, which may be the same material, are installed on the roof deck or slab. Here they are firmly supported by the roof deck and protected by the insulation. Condensation may occur at the membrane or on the underside of the roof deck because of inadequate insulation.

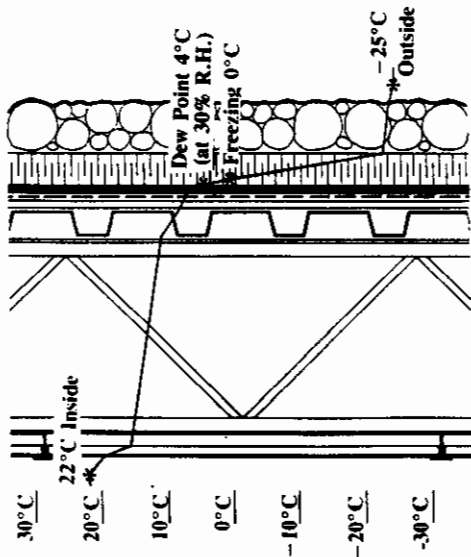

	RSI-value
Outside Air Film	0.030
76 mm Gravel Ballast	0.046
50 mm Polystyrene Insulation	1.285
Built-up Roofing/Vapor Barrier	0.058
12 mm GWB	0.074
Metal Deck	0.123
Air Space	0.180
12 mm Acoustic Tile	0.220
Inside Air Film	0.105
RSI =	2.121

$$U = \frac{1}{2.121} = 0.47$$

Inverted Roof
Figure 17

Improvement - Remove the existing gravel ballast, add insulation and reinstall the ballast. Additional gravel ballast equal to the weight equivalent to the insulation flotation effect must then be added (Figure 18). This improvement is a simple task because the membrane is not disrupted, but there may be a severe structural implication owing to the extra weight. Structural limitations *must* be assessed by a qualified engineer.

Advantage - The extra insulation moves the dew point further outside, keeping the membrane vapor barrier warm enough to eliminate condensation.

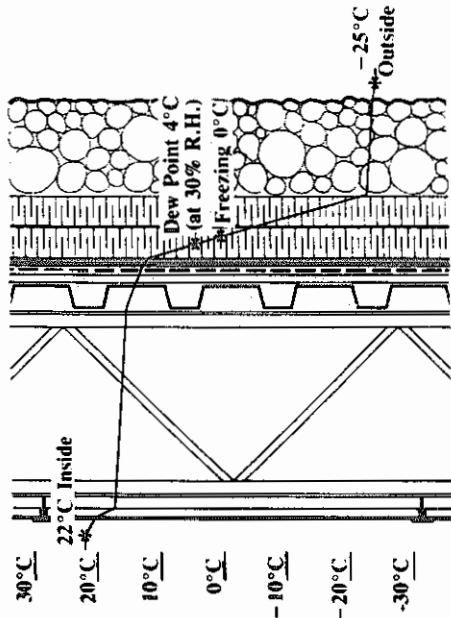

	RSI-value
Outside Air Film	0.030
152 mm Gravel Ballast	0.092
100 mm Polystyrene Insulation	2.570
Built-up Roofing/Vapor Barrier	0.058
12 mm Gravel	0.074
Metal Deck	0.123
Air Space	0.180
12 mm Acoustic Tile	0.220
Inside Air Film	0.105
Total	RSI = 3.452

$$U = \frac{1}{3.452} = 0.29$$

**Inverted Roof
(Improvement)
Figure 18**

Floors

The ground floor of a building, whether suspended or slab-on-grade, is effectively insulated by the insulation of the perimeter foundations. Because the temperature differential across the floor is small, the heat transfer rate is considered to be negligible.

Windows

The following features are common to all types of windows.

- **Glazing** represents the major part of the window. It passes light while inhibiting heat transmission. Heat absorbing or tinted glass can be employed to reduce solar gain, while double or triple glass will reduce heat loss and gain. Glazing may break as a result of large temperature differences between the inside and outside of the window. Radiators should be kept outside of drapes to allow air circulation.
- The **frame** that holds the glass is a potential source of air and water infiltration if a poor seal exists between the frame and wall or between the frame and openable sash. Infiltration can be lessened by weather-stripping and caulking. Sealing components should be replaced if damaged.
- A **sash** is an opening glass frame and if improperly closed will allow air leakage. A storm sash can reduce air leakage and heat loss through the glass by acting as an additional glazed layer of protection.
- Window **latches** ensure the complete closing of operating windows. Damaged or broken latches should be repaired or replaced. Openable windows provide uncontrolled ventilation and should be avoided if the building is air-conditioned.
- **Shading devices** reduce unwanted solar radiation through windows. Venetian blinds, vertical blinds, shutters, or drapes provide internal shade. External shading devices may be desirable depending on the orientation and amount of glazing present. Roof overhangs, horizontal or vertical louvers (usually adjustable), and lattice screens of wood, metal or masonry are examples of external shading devices.

Windows must be considered in terms of heat gain in summer and heat loss in winter. An apparent energy opportunity to reduce window area must be balanced against needs for view, light and ventilation.

Glazing

Improvement - Alternative A - Add double or triple glazing in the form of sealed units (Figure 19). If required, change the frame to accommodate the thermal pane. Wood frames are easily adapted, but it may be more practical to use aluminum.

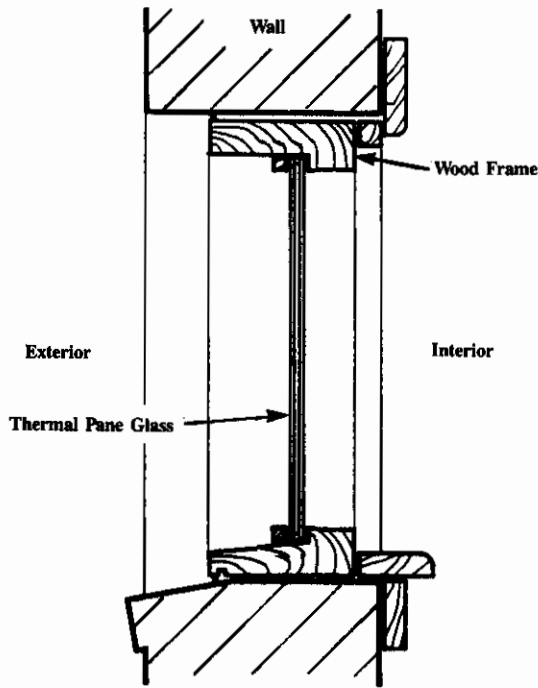

Single Glazing	RSI-value
Outside Air Film	0.030
Glass	0.020
Inside Air Film	0.120
	RSI = 0.170

$$U = \frac{1}{0.170} = 5.88$$

Thermal Pane	RSI-value
Outside Air Film	0.030
Glass	0.020
Air Space	0.171
Glass	0.020
Inside Air Film	0.120
	RSI = 0.361

$$U = \frac{1}{0.361} = 2.77$$

Sealed Glazing
Figure 19

Improvement - Alternative B - Add a second skin of glazing to the *inside* of the window (Figure 20).

A pane of glass, usually with an aluminum frame, is secured to the existing window frame. A reusable gasket allows this second pane to be removed for cleaning since the assembly is not sealed. A hole must be drilled through the frame to allow minimum ventilation of the air space. This method is common for wood-frame windows, but it may also be used for steel or aluminum frames. Interior mounting of the glazing is for convenience only.

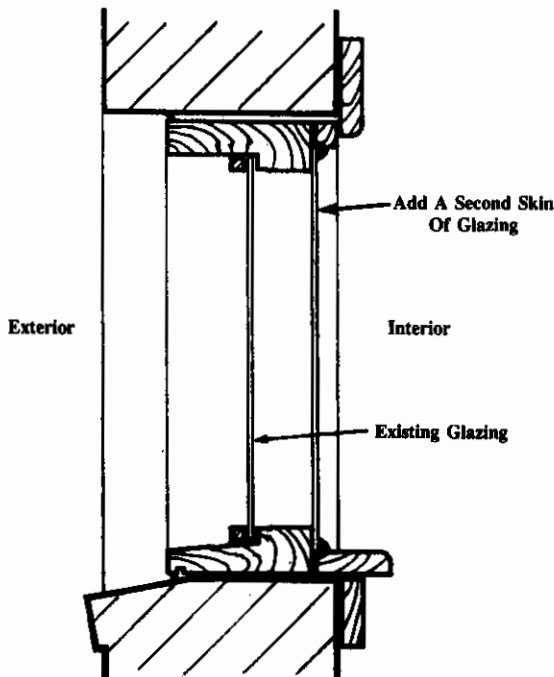

Thermal Pane	RSI-value
Outside Air Film	0.030
Glass	0.020
Air Space	0.171
Glass	0.020
Inside Air Film	0.120
	RSI = 0.361

$$U = \frac{1}{0.361} = 2.77$$

Double Glazing
(Interior)
Figure 20

Improvement - Alternative C - Place a storm window on the *outside* of the existing window. Storm windows may be attached to the existing frame or beyond it, but should be removable for cleaning purposes (Figure 21).

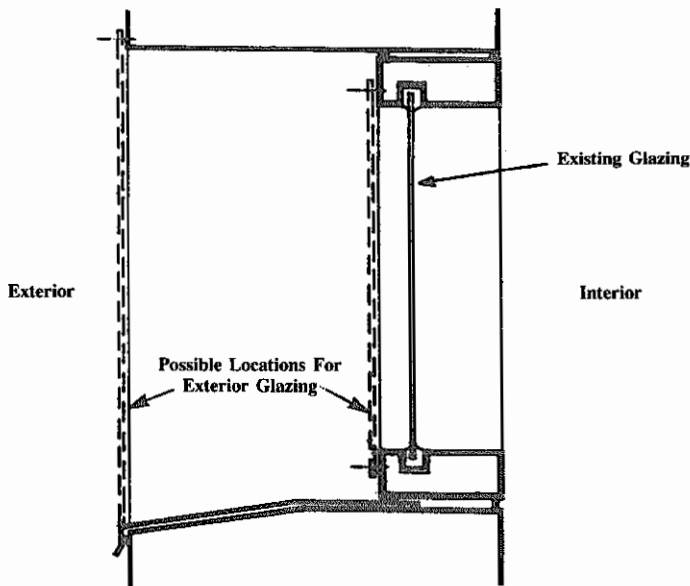

Thermal Pane	RSI-value
Outside Air Film	0.030
Glass	0.020
Air Space	0.171
Glass	0.020
Inside Air Film	<u>0.120</u>
RSI = 0.361	

$$U = \frac{1}{0.361} = 2.77$$

**Double Glazing
(Exterior)**
Figure 21

Improvement - Alternative D - Add reflecting or tinted film to the existing glazing (Figure 22). The film, which is applied to the interior surface of the glass, can be easily installed even in multistorey buildings. The reduction in the sun's effects depends on the type of film used.

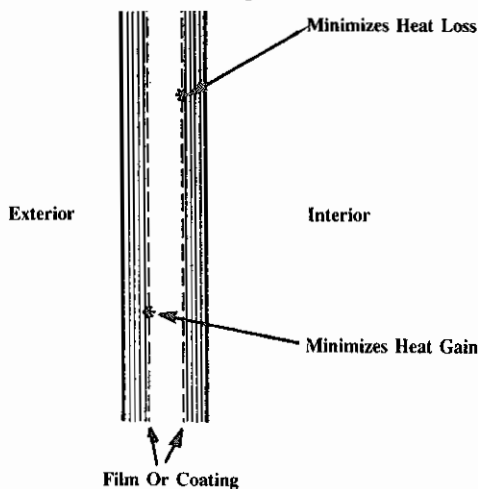

Reflective Film
Figure 22

Reflective glass in double-glazed units can reduce energy loss. Depending on the glass surface(s) upon which the reflective coating is placed, heat gain or loss, or both, can be reduced. If the outside surface of the inner pane is coated, heat loss will be reduced because the air space is warmed. If the inner surface of the outer pane is coated, solar heat gain will be reduced because the sun's rays are reflected back through the outer glazing before entering the air space.

Tinted films affect the building's appearance. The darker and more reflective films have the greatest effect. When the reflecting surface faces outwards, the exterior appearance is uniform, although perhaps unwelcoming. When the reflecting surfaces face the inside the mirrored panes can sometimes be bothersome to workers in late afternoon or evening.

Reduction of the summer air-conditioning load requires that only the south, east and west windows be treated, but for uniformity of appearance the addition of film to the north windows is often included. Although the addition of film on the north windows may be justified on the basis of appearance it is significant to note that winter heat loss is reduced as well. While the percentage saving to heating is less, this saving accrues 24 hours per day during the heating season.

To ensure that glass cracking does not result, particular caution must be exercised in the use of films with special glazing such as wired glass and thermal pane units. The appropriate selection to suit the application should be made with the assistance of suppliers.

Frames

Wood Construction - Wood is effective for thermal resistance, but requires substantial maintenance.

Aluminum Construction - Aluminum frames are available in standard and thermally broken types. The standard frames provide a continuous aluminum cross section which allows thermal bridging that also promotes condensation on the frame. Thermally broken frames are larger in cross sectional area because of the inclusion of a polyvinyl chloride (PVC) or neoprene spacer between the inner and outer parts of the frame to prevent thermal bridging.

Steel Construction - The combination of a highly conductive material with a slim profile results in the greatest heat loss. This type of frame is common with single glazing and opening windows in older industrial buildings (Figure 23).

Improvement - Opening Sash- Open windows can be a source of infiltration, which perhaps is necessary if there is no mechanical ventilation or make up air system. It is important to educate staff concerning window use. If a decision is taken to permanently close the opening sash, it can be effected by removing the hardware from the frames.

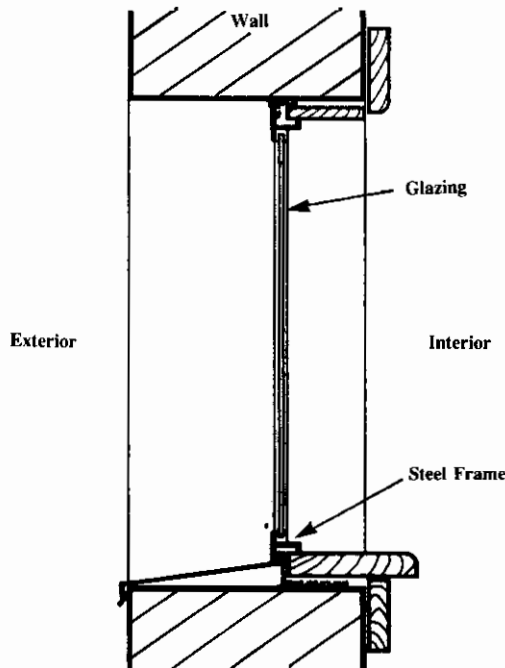

Steel Frame
Figure 23

Shading Devices

Improvement - Drapes can improve a building's thermal performance by reducing drafts, heat loss and heat gain. Their location is important. If they cover the heating units the effectiveness of the heating system can be substantially reduced.

Improvement - Exterior shades are the most effective shading devices. They reduce heat gain by shading the window areas from the outside, so that the sun's rays never reach the interior of the building. Consisting of either horizontal or vertical louvers, they are costly to install and require substantial maintenance.

Improvement - Interior blinds as interior shading devices are not as effective as the exterior type as the sun's rays enter the building and heat up the blinds, air and other elements. They are, however, less expensive to install, and can improve the building's appearance.

Doors

There are many types of doors including hollow or solid core wood, hollow metal with or without insulation, glazed, swinging, sliding and revolving. Thermal resistance varies according to the specific construction.

Air infiltration is the major problem of open and closed doors. Air movement occurs between the door and the frame along the sill (bottom), head (top), and jamb (sides). Weather-stripping reduces the air flow and is available for door jambs in the form of metal springs and plates, vinyl inserts and gaskets and plastic and rubber sponges. Door sills and heads make use of metal springs and metal hook strips, vinyl inserts, and gaskets of neoprene, felt or rubber. Infiltration can be minimized by ensuring that all door closers work properly and that the door is firmly hinged to the frame.

While the type of door has an effect on heat loss, it is less significant than the heat loss which occurs when the door is open. In new building planning and design, doorways should be protected, or located away from prevailing winter winds. In existing buildings the addition of a *vestibule* is the most effective means of improvement. The vestibule must be large enough for convenient entry, and long enough to allow one set of doors to close before the other is opened. (Figure 24).

With or without a vestibule enclosure, every measure should be taken to ensure that the door opening is weather-tight. These measures would include weather-stripping on three sides, weatherproof thresholds at the door sill, and a properly adjusted door closer to provide easy opening and a quick smooth closure

Revolving doors reduce infiltration/exfiltration by ensuring that there is never a direct opening to the outdoors. The action, in this respect, is similar to a vestibule. The installation of revolving and automatic doors is expensive and practical only where traffic loads are particularly high.

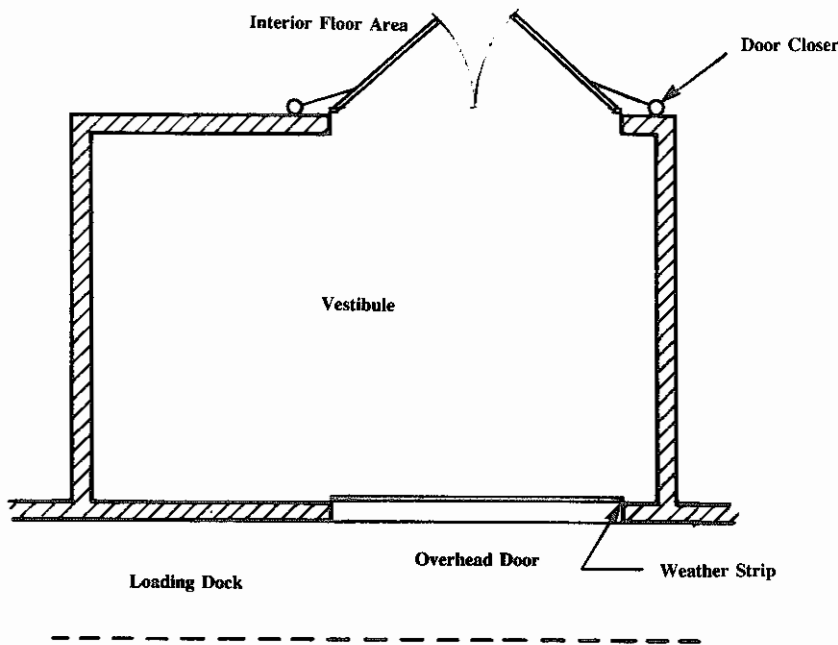

Vestibule
Figure 24

Loading Docks

The enclosed loading dock provides worker comfort to facilitate operating effectiveness, but may be considered an inefficient use of building space. In the past, this type of dock was common in warehouses for transport trucks and railway cars, but current trends only use this approach in special high-volume areas.

Currently, the most common and economical approach to loading docks is the overhead door that is aligned with the edge of the loading dock and provided with rubberized seals. These seals can be adjustable in height, but are most frequently installed to the dimensions of the typical transport trailer. The trailer, backed tightly against the seal, eliminates most air gaps. Refer to Module 17, Materials Handling and On-Site Transportation Equipment, for more detailed information.

Where an outdoor loading dock exists, improvements to reduce energy consumption can include relocating the old doors, or installing new doors at the outer edge. In addition, the benefits of a shipping vestibule or staging area can be considered. While such an arrangement may appear to hinder flow of materials, the problem can be minimized by the use of flexible (rubber) doors or vinyl strip draft screens installed in doorways. Pressurizing the vestibule with heated air can add to the comfort, but more energy will be required.

ENERGY MANAGEMENT OPPORTUNITIES



Energy Management Opportunities is the term that represents the ways energy can be used wisely to save money. A number of typical Energy Management Opportunities, subdivided into Housekeeping, Low Cost and Retrofit categories are outlined in this section with worked examples to illustrate the potential energy savings. This is not a complete listing of the opportunities available for architectural considerations. However, it is intended to provide ideas for management, operating and maintenance personnel to identify opportunities that are applicable to a particular facility. Appropriate modules in this series should also be considered for Energy Management Opportunities existing within other types of equipment and systems.

Housekeeping Opportunities

Implemented housekeeping opportunities are energy management actions that are done on a regular basis and never less than once a year. The following are typical Energy Management Opportunities in this category.

1. Ensure that outside and inside doors which separate areas of different ambient conditions are closed. Eliminate door stops on self-closing doors between areas of different conditions.
2. Adjust freight shipping and receiving procedures to reduce the time that loading doors are open, particularly in winter.
3. Adjust door hardware to ensure smooth, quick and complete closure.
4. Adjust or replace window hardware to eliminate unwanted air movement through the building skin.
5. Operate window shading devices properly, i.e., close drapes and blinds during summer months and open them during winter months when exposed to direct sunlight.
6. Repair torn or badly fitting dock seals.
7. Check and adjust building automatic temperature settings.
8. Inspect and repair leaks and openings in the ventilation and air-conditioning system.

Low Cost Opportunities

Implemented low cost opportunities are energy management actions that are done once and for which the cost is not great. The following are typical Energy Management Opportunities in this category.

1. Caulk improperly sealed joints between window frames and wall and weather-strip openings.
2. If there are more than enough windows in the building envelope for light and comfort, blank off, insulate and seal unnecessary windows.
3. Permanently seal windows if summer cooling and ventilation systems have been installed.
4. Replace glass panes which are cracked or broken.
5. Apply tinted and reflecting films to glass to reduce solar gain. Drapes, blinds and shutters are also effective.
6. Install automatic door closers to minimize outside air infiltration.
7. Replace damaged, poorly fitting, low RSI-value doors, such as hollow metal types.
8. Make repairs to walls and roofs. Minor repairs at minimal cost often result in significant benefits. Visible damage, including gaps in the outside cladding, and leaks in the roof membrane should be repaired.
9. Make repairs where insulation is missing or damaged or the vapor barrier has been perforated.

Low Cost Worked Examples

1. Seal Windows And Add Weather-Stripping

An industrial building located in Minden, Ontario, has wood sash windows in the office area and industrial pivoted windows in the adjoining warehouse. Total measured crack lengths are 150 m for the wood sash windows and 280 m for the industrial pivoted windows. There are four man doors, each 1 m wide x 2 m high, and four overhead doors in receiving, each having a sectional 5 panel door, 3 m x 3 m. Infiltration rates per meter of crack length from Table 3 were used to calculate both the present infiltration rate and the expected infiltration rate after sealing and weather-stripping is completed. Energy savings are calculated in Worked Example 1 using Worksheet 18-1.

Potential savings of \$12,506 per year result from improvements estimated to cost \$8,000. Simple payback is 8 months.

2. Caulk Joints

Architectural pivoted type windows in a building located in Minden, Ontario, were found to have an average crack width of 1.2 mm at the joints around the windows. Total crack length was 300 m. The building was heated by an oil furnace, using fuel that cost \$0.45 per litre. It was proposed that all joints be caulked to reduce the effective crack width to an average of 0.8 mm. From Table 3, existing and proposed infiltration rates were calculated, from which the total energy savings were estimated. These calculations are shown in Worked Example 2 using Worksheet 18-1.

By reducing the total infiltration rate from 684 L/s to 480 L/s, savings of \$1,538 per year were obtained. Simple payback for the \$600 cost of caulking was 7 months.

3. Add Dock Seal

Infiltration at a loading dock operation in winter results in cold drafts and worker complaints. Energy dollars can be saved and worker comfort improved by adding a dock seal that reduces the opening size. For example, two loading doors at a small warehouse have a 150 mm gap at the jambs and head during loading. The doors are used for 3 hours per day, 5 days per week. The doors are 2.4 m high x 2.4 m wide. Space heating is accomplished with an oil furnace.

It is proposed to reduce the size of the the 150 mm wide gap between the trailers and door frame to 25 mm by adding dock seals. Design outside temperature is -26°C , inside temperature is 20°C and there are 4966 degree days heating at the site. Cost of oil is \$0.45 per litre. Savings are calculated in Worked Example 3 using Worksheet 18-4.

Potential savings of \$822 per year would result from the installation of dock seals estimated to cost \$2,000. A simple payback of 2.5 years will result when door operation is 15 hours per week. Any increase in door operation will reduce this payback period.

Retrofit Opportunities

Implemented retrofit opportunities are energy management actions that are done once and for which the cost is significant. Some opportunities in this category require analysis by specialists and cannot be covered in this module. However, worked examples are provided for Energy Management Opportunities considered typical in the retrofit category.

1. Consider treatment to openings in the building envelope, such as doors, windows and loading docks.
2. Replace high volume exterior doors with revolving units.
3. Provide well constructed weathertight vestibules for high usage openings.
4. Install dock seals at shipping and receiving doors.
5. Install additional roof insulation and repair roofing membrane.
6. Upgrade wall vapor barrier and insulation.
7. Reduce glazing area by blocking off unnecessary windows or adding storm windows to single pane units.

Retrofit Worked Examples

1. Remove Siding/Add Insulation/Reinstall Siding

A 7000 m² warehouse, with a net wall area of 1240 m², is constructed of panel walls and 50 mm fiberglass insulation. The warehouse is situated in Minden, Ontario, where the winter outdoor design temperature is -26°C and there are 4966 degrees days below 18°C . The space temperature is kept at 20°C . The cost of fuel oil used for heating is \$0.45 per litre.

It is proposed to remove the existing exterior siding and add another 50 mm of insulation, at a cost of \$15,000 for labor and materials. Energy savings of \$2,103 result from this improvement, according to the calculations of Worked Example 1, Worksheet 18-2. Simple payback is 7.1 years.

Insulation improvements results in long paybacks because a large labor component is usually involved.

2. Add Insulated Metal Siding To Brickfaced Wall

An existing plant, with a net wall area of 360 m², is constructed with concrete block and brickfaced walls. Since its appearance had deteriorated with time, it was intended to upgrade the building's appearance by installing colored metal siding over the existing brick. Further analysis revealed that installing a more expensive insulated panel would result in energy savings.

The insulated panel wall has an RSI value of 1.612 ($U = 0.62$), as compared to 0.572 for the initially proposed plain steel siding improvement. The building was located in London, Ontario, where the winter design temperature is -18°C and there are 4067 degree days below 18°C . The interior temperature is kept at 20°C and the building is heated with natural gas costing \$0.21 per cubic meter.

The estimated costs were \$13,000 and \$17,000 for the uninsulated and insulated panels respectively. The energy and cost savings resulting from the additional insulation were calculated in Worked Example 2 using Worksheet 18-2. Assuming that the new siding is required, the proposed insulated alternative would lead to energy savings of \$1,034 per year at an additional cost of $\$17,000 - \$13,000 = \$4,000$. The simple payback is the incremental cost divided by the annual savings.

$$\text{Simple payback} = \frac{4000}{1034} = 3.9 \text{ years}$$

3. Insulate Glazing Panels

Cold drafts from an existing 35 m² single glazed skylight caused worker discomfort in a factory in New Liskeard, Ontario. The skylight also produced undesirable lighting changes in the process area below. After examining several possible solutions, sealing the skylight and insulating the glazed frame areas were found to save the most energy dollars. Elimination of drafts and lighting problems were side benefits. Energy dollar savings are calculated in Worked Example 3 using Worksheet 18-2.

Potential savings of \$1,405 per year result from this improvement estimated to cost \$3,000. Simple payback is 2.1 years.

4. Increase Wall Insulation

A new building was to be built in Minden, Ontario. The contractor had proposed that the walls be built of insulated metal panels with 38 mm fiberglass. Concerned with energy costs, the owner considered increasing the amount of insulation to 88 mm. The cost of this additional 50 mm of insulation would be \$1600 per 100 m² of wall area.

Based on calculations shown in Worked Example 4, Worksheet 18-2, the annual energy savings would be \$281 per 100 m², for a simple payback of 5.7 years. If the payback period exceeded company payback guidelines, the calculation could be repeated using different thicknesses of insulation. It might be possible to install a reduced amount of extra insulation to save energy and meet the company's investment criteria.

5. Add Roof Insulation

A diagnostic energy audit revealed that a 1970 m² plant had two types of roof construction, both of low thermal resistance which contributed significantly to high heat losses. It was proposed to add 30 mm of urethane foam to the roof construction. The Transmittance (U) value of the type 'A' roof was reduced from 0.782 to 0.394, and for the type 'B' roof, from 1.709 to 0.542 W/m²·C.

With 4966 degree days and a -26°C outdoor temperature, annual energy savings would be \$7,516. Cost of upgrading the insulation would be \$39,400. As shown in Worked Example 5, Worksheet 18-3, the payback is 5.2 years.

Infiltration — Doors And Windows

Worksheet 18-1

Page 1 of 3

Company: WORKED EXAMPLE 1

Date: JAN. 22 / 86

Location: LOW COST

By: MBE

DESIGN REQUIREMENTS:

Temperature inside 20 °C (1)

Temperature outside -26 °C (2)

(1) - (2) = 20 - (-26) = 46 °C (3)

Degree Days below 18.0°C 4966 (4)
(Obtain from N.B.C.)

FUEL COSTS:

(Obtain from utility bills)

Gas ----- (Cf) (\$/m³) _____ (5)

Oil ----- (Cf) (\$/L) 0.45 (6)

Electricity ----- (Ce) (\$/kWh) _____ (7)
(Ignore demand charges)

EXISTING DOORS AND WINDOWS:

(Summarize sizes, types, condition, lengths and sizes of cracks, and frequency of opening.)

Existing Windows -

Type 1:

SMALL
- AVERAGE FITTED WOODEN SASH
- TOTAL CRACK LENGTH = 150 M
(WINDWARD SIDE)

Type 2:

INDUSTRIAL PIVOTED
- TOTAL CRACK LENGTH = 280 M
(WINDWARD SIDE)

Type 3:

Existing Doors -

Type 1:

MANDOORS (4)
- EACH 1 M x 2 M

Type 2:

OVERHEAD RECEIVING (4)
- 5 SECTIONS
- 3 M x 3 M (WINDWARD)

Type 3:

Infiltration — Doors And Windows

Worksheet 18-1

Page 2 of 3

Company: WORKED EXAMPLE 1 Date: JAN. 22/86

Location: LOW COST By: MBE

EXISTING INFILTRATION BY "CRACK" METHOD (See Table 3)

		Length (m)		Infiltration Rate [L/(s·m)]		Total Infiltration (L/s)
Doors:	Type #1	<u>24</u>	x	<u>5.7</u>	=	<u>137</u>
	#2	<u>96</u>	x	<u>14.9</u>	=	<u>1430</u>
	#3		x		=	
Windows:	Type #1	<u>150</u>	x	<u>1.01</u>	=	<u>152</u>
	#2	<u>280</u>	x	<u>4.49</u>	=	<u>1257</u>
	#3		x		=	
Existing Infiltration =						<u>2976</u> (8)

PROPOSED IMPROVEMENTS:

*ADD WEATHER STRIPPING TO SMALL DOORS AND
WINDOWS, SEAL INDUSTRIAL WINDOWS.*

REVISED INFILTRATION BY "CRACK" METHOD:

		Length (m)		Infiltration Rate [L/(s·m)]		Total Infiltration (L/s)
Doors:	Type #1	<u>24</u>	x	<u>1.4</u>	=	<u>34</u>
	#2	<u>96</u>	x	<u>5.7</u>	=	<u>547</u>
	#3		x		=	
Windows:	Type #1	<u>150</u>	x	<u>0.62</u>	=	<u>93</u>
	#2	<u>280</u>	x	<u>2.28</u>	=	<u>638</u>
	#3		x		=	
Revised Infiltration =						<u>1312</u> (9)

Infiltration — Doors And Windows
Worksheet 18-1
Page 3 of 3

Company: WORKED EXAMPLE 1 Date: JAN. 22/86
 Location: LOW COST By: MBE

INFILTRATION REDUCTION (fa):

fa = existing infiltration — revised infiltration

$$= \underline{2976} \text{ (8)} - \underline{1312} \text{ (9)} = \underline{1664} \text{ (L/s) (10)}$$

Total Infiltration (Heat Loss) Reduction:

$$Q = 1.232 \times fa \times (T_2 - T_1)$$

$$= 1.232 \times \underline{1664} \text{ (10)} \times \underline{46} \text{ (3)} = \underline{94302} \text{ (W) (11)}$$

$$\text{i.e.} = \frac{\underline{94302} \text{ (11)}}{1000} = \underline{94.3} \text{ kW (12)}$$

ESTIMATED ENERGY COST SAVINGS PER ANNUM:

GAS: N/A

$$= 2.95 \times \underline{\hspace{2cm}} \text{ (5)} \times \underline{\hspace{2cm}} \text{ (12)} \times \frac{\underline{\hspace{2cm}} \text{ (4)}}{\underline{\hspace{2cm}} \text{ (3)}} = \$ \underline{\hspace{2cm}} \text{ (13)}$$

OIL:

$$= 2.73 \times \underline{0.45} \text{ (6)} \times \underline{94.3} \text{ (12)} \times \frac{\underline{4966} \text{ (4)}}{\underline{46} \text{ (3)}} = \$ \underline{12,506} \text{ (14)}$$

ELECTRICITY: N/A

$$= 16.8 \times \underline{\hspace{2cm}} \text{ (7)} \times \underline{\hspace{2cm}} \text{ (12)} \times \frac{\underline{\hspace{2cm}} \text{ (4)}}{\underline{\hspace{2cm}} \text{ (3)}} = \$ \underline{\hspace{2cm}} \text{ (15)}$$

ESTIMATED COST OF IMPROVEMENT: \$ 8000 (16)

TOTAL ESTIMATED SAVINGS PER ANNUM:

$$\underline{\hspace{2cm}} \text{ (13)} + \underline{12,506} \text{ (14)} + \underline{\hspace{2cm}} \text{ (15)} = \$ \underline{12,506} \text{ (17)}$$

$$\text{SIMPLE PAYBACK} = \frac{\underline{8000} \text{ (16)}}{\underline{12,506} \text{ (17)}} = \underline{0.64} \text{ years} \\ \text{(8 MONTHS)}$$

Infiltration — Doors And Windows

Worksheet 18-1

Page 1 of 3

Company: WORKED EXAMPLE 2

Date: JAN. 22/86

Location: LOW COST

By: MBE

DESIGN REQUIREMENTS:

Temperature inside 20 °C (1)

Temperature outside -26 °C (2)

(1) - (2) = 20 - (-26) = 46 °C (3)

Degree Days below 18.0°C 4966 (4)
(Obtain from N.B.C.)

FUEL COSTS:

(Obtain from utility bills)

Gas ----- (Cf) (\$/m³) _____ (5)

Oil ----- (Cf) (\$/L) 0.45 (6)

Electricity ----- (Ce) (\$/kWh) _____ (7)
(Ignore demand charges)

EXISTING DOORS AND WINDOWS:

(Summarize sizes, types, condition, lengths and sizes of cracks, and frequency of opening.)

Existing Windows -

Existing Doors -

Type 1:

Type 1:

ARCHITECTURAL PIVOTED

- AVERAGE CRACK SIZE = 1.2 mm

- CRACK LENGTH = 300 M

Type 2:

Type 2:

Type 3:

Type 3:

Infiltration — Doors And Windows

Worksheet 18-1

Page 2 of 3

Company: WORKED EXAMPLE 2 Date: JAN. 22/86

Location: LOW COST By: MBE

EXISTING INFILTRATION BY "CRACK" METHOD (See Table 3)

	Length (m)		Infiltration Rate [L/(s·m)]		Total Infiltration (L/s)
Doors: Type #1	_____	x	_____	=	_____
#2	_____	x	_____	=	_____
#3	_____	x	_____	=	_____
Windows: Type #1	<u>300</u>	x	<u>2.28</u>	=	<u>684</u>
#2	_____	x	_____	=	_____
#3	_____	x	_____	=	_____
Existing Infiltration =					_____ (8)

PROPOSED IMPROVEMENTS:

- CALLK ALL JOINTS TO REDUCE AVERAGE CRACK SIZE TO 0.8 mm

REVISED INFILTRATION BY "CRACK" METHOD:

	Length (m)		Infiltration Rate [L/(s·m)]		Total Infiltration (L/s)
Doors: Type #1	_____	x	_____	=	_____
#2	_____	x	_____	=	_____
#3	_____	x	_____	=	_____
Windows: Type #1	<u>300</u>	x	<u>1.60</u>	=	<u>480</u>
#2	_____	x	_____	=	_____
#3	_____	x	_____	=	_____
Revised Infiltration =					<u>480</u> (9)

Infiltration — Doors And Windows

Worksheet 18-1

Page 3 of 3

Company: WORKED EXAMPLE 2 Date: JAN. 22/86

Location: LOW COST By: MBE

INFILTRATION REDUCTION (fa):

fa = existing infiltration — revised infiltration

$$= \underline{684} \text{ (8)} - \underline{480} \text{ (9)} = \underline{204} \text{ (L/s) (10)}$$

Total Infiltration (Heat Loss) Reduction:

$$Q = 1.232 \times fa \times (T_2 - T_1)$$

$$= 1.232 \times \underline{204} \text{ (10)} \times \underline{46} \text{ (3)} = \underline{11561} \text{ (W) (11)}$$

$$\text{i.e.} = \frac{\underline{11561} \text{ (11)}}{1000} = \underline{11.6} \text{ kW (12)}$$

ESTIMATED ENERGY COST SAVINGS PER ANNUM:

GAS: N/A

$$= 2.95 \times \underline{\hspace{2cm}} \text{ (5)} \times \underline{\hspace{2cm}} \text{ (12)} \times \frac{\underline{\hspace{2cm}} \text{ (4)}}{\underline{\hspace{2cm}} \text{ (3)}} = \$ \underline{\hspace{2cm}} \text{ (13)}$$

OIL:

$$= 2.73 \times \underline{0.45} \text{ (6)} \times \underline{11.6} \text{ (12)} \times \frac{\underline{4966} \text{ (4)}}{\underline{46} \text{ (3)}} = \$ \underline{1,538} \text{ (14)}$$

ELECTRICITY: N/A

$$= 16.8 \times \underline{\hspace{2cm}} \text{ (7)} \times \underline{\hspace{2cm}} \text{ (12)} \times \frac{\underline{\hspace{2cm}} \text{ (4)}}{\underline{\hspace{2cm}} \text{ (3)}} = \$ \underline{\hspace{2cm}} \text{ (15)}$$

ESTIMATED COST OF IMPROVEMENT: \$ 600 (16)

TOTAL ESTIMATED SAVINGS PER ANNUM:

$$\underline{\hspace{2cm}} \text{ (13)} + \underline{1,538} \text{ (14)} + \underline{\hspace{2cm}} \text{ (15)} = \$ \underline{1,538} \text{ (17)}$$

$$\text{SIMPLE PAYBACK} = \frac{\underline{600} \text{ (16)}}{\underline{1,538} \text{ (17)}} = \underline{0.39} \text{ years}$$

(5 MONTHS)

Infiltration — Large Openings
Worksheet 18-4
Page 1 of 3

Company: WORKED EXAMPLE 3

Date: JAN. 22/86

Location: LOW COST

By: MBE

DESIGN REQUIREMENTS:

Temperature inside 20 °C (1)

Temperature outside -26 °C (2)

(1) - (2) = 20 - (-26) = 46 °C (3)

Degree Days below 18.0°C 4966 (4)
(Obtain from N.B.C.)

FUEL COSTS:

(Obtain from utility bills)

Gas ----- (Cf) (\$/m³) _____ (5)

Oil ----- (Cf) (\$/L) 0.45 (6)

Electricity ----- (Ce) (\$/kWh) _____ (7)
(Ignore demand charges)

EXISTING OPENING:

(Summarize details of size and frequency of opening.)

- 2 LOADING DOORS, EACH 2.4 M x 2.4 M, NO DOCK SEALS.
- 150 mm GAP AT JAMBS AND HEAD DURING LOADING
- OPEN 3 HRS/DAY, 5 DAYS/WEEK

$$2.4 \times 3 \times 0.150 \times 2 = \text{Area of opening } \underline{2.16} \text{ m}^2 \quad (8)$$

$$3 \times 5 = \text{Time area is open/week } \underline{15} \text{ h} \quad (9)$$

EXISTING INFILTRATION:

$f_a = E_o \times A \times V \times 1000 \times OT$ (see Fundamentals)

$$= 0.4 \times \text{_____} (8) \times 1.7 \times 1000 \times \text{_____} (9) = \text{_____} (10), \text{ or}$$

168

$$= 4.05 \times \underline{2.16} (8) \times \underline{15} (9) = \underline{1.31} (10)$$

Infiltration — Large Openings
Worksheet 18-4
Page 2 of 3

Company: WORKED EXAMPLE 3 Date: JAN. 22/86
 Location: LOW COST By: MBE

PROPOSED IMPROVEMENTS:

*- ADD A DOCK SEAL TO REDUCE SIZE OF
 OPENING WIDTH TO 25 mm AVERAGE*

$$2.4 \times 3 \times 0.025 \times 2 \text{ Area of opening } \underline{0.36} \text{ m}^2 \quad (11)$$

$$\text{Time area is open/week } \underline{15} \text{ h} \quad (12)$$

REVISED INFILTRATION:

$$fa = E_o \times A \times V \times 1000 \times OT \text{ (see Fundamentals)}$$

$$= 0.4 \times \text{_____} (11) \times 1.7 \times 1000 \times \text{_____} (12) = \text{_____} (13), \text{ or}$$

168

$$= 4.05 \times \underline{0.36} (11) \times \underline{15} (12) = \underline{22} (13)$$

INFILTRATION REDUCTION (fa):

$$fa = \text{existing infiltration} - \text{revised infiltration}$$

$$= \underline{131} (10) - \underline{22} (13) = \underline{109} \text{ (L/s)} (14)$$

Total Infiltration (Heat Loss) Reduction:

$$Q = 1.232 \times fa \times (T_2 - T_1)$$

$$= 1.232 \times \underline{109} (14) \times \underline{46} (3) = \underline{6177} \text{ (W)} (15)$$

$$\text{i.e.} = \frac{\underline{6177}}{1000} (15) = \underline{6.2} \text{ kW} (16)$$

Infiltration — Large Openings

Worksheet 18-4

Page 3 of 3

Company: WORKED EXAMPLE 3 Date: JAN. 22/86

Location: LOW COST By: MRE

ESTIMATED ENERGY COST SAVINGS PER ANNUM:

GAS: N/A

$$= 2.95 \times \text{_____} (5) \times \text{_____} (16) \times \text{_____} (4) = \$ \text{_____} (17)$$

_____ (3)

OIL:

$$= 2.73 \times \underline{0.45} (6) \times \underline{6.2} (16) \times \frac{\underline{4966}}{\underline{46}} (4) = \$ \underline{822} (18)$$

ELECTRICITY: N/A

$$= 16.8 \times \text{_____} (7) \times \text{_____} (16) \times \text{_____} (4) = \$ \text{_____} (19)$$

_____ (3)

ESTIMATED COST OF IMPROVEMENT: \$ 2,000 (20)

TOTAL ESTIMATED SAVINGS:

$$\text{_____} (17) + \underline{822} (18) + \text{_____} (19) = \$ \underline{822} (21)$$

$$\text{SIMPLE PAYBACK} = \frac{\underline{2000} (20)}{\underline{822} (21)} = \underline{2.4} \text{ years}$$

Heat Transmission — Walls

Worksheet 18-2

Page 1 of 2

Company: WORKED EXAMPLE 1 Date: JAN. 22/86

Location: RETROFIT By: MBE

DESIGN REQUIREMENTS:

Temperature inside 20 °C (1)

Temperature outside -26 °C (2)

(1) - (2) = 20 - (-26) = 46 °C (3)

Degree Days below 18.0°C 4966 (4)
(Obtain from N.B.C.)

FUEL COSTS:

(Obtain from utility bills)

Gas ----- (Cf) (\$/m³) _____ (5)

Oil ----- (Cf) (\$/L) 0.45 (6)

Electricity ----- (Ce) (\$/kWh) _____ (7)
(Ignore demand charges)

WALL CONSTRUCTION "EXISTING"

RSI = 1.484

U = $\frac{1}{RSI} = \frac{1}{1.484} = 0.674$ (8)

SKETCH OR DESCRIBE "EXISTING" CONDITIONS

OUTSIDE AIR FILM	0.030
METAL SIDING	0.123
AIR SPACE	0.171
50mm F.G. INSULATION	1.040
LINER SHEET	NEGL.
INSIDE AIR FILM	0.120
	1.484

WALL CONSTRUCTION "PROPOSED"

RSI = 2.524

U = $\frac{1}{RSI} = \frac{1}{2.524} = 0.396$ (9)

SKETCH OR DESCRIBE "PROPOSED" CONDITIONS

REMOVE SIDING	_____
ADD 50mm F.G. INSULATION	1.040
REINSTALL SIDING	_____
EXISTING WALL	1.484
	2.524

See Materials/Systems Section and Table 1 in Appendix B for RSI-value of various building materials.

Heat Transmission — Walls

Worksheet 18-2

Page 2 of 2

Company: WORKED EXAMPLE 1 Date: JAN. 22/86

Location: RETROFIT By: MBE

Net Wall Area (wall area minus area of all doors and windows)

Length x Width = _____ x _____ = _____ m²

Windows (sash area) (-) _____ m²

Doors (frame area) (-) _____ m²

Net Wall Area = 1240 m² (10)

Heat Loss (Existing) = 0.674 (8) x 1240 (10) x 46 (3) = 38444 W (11)

Heat Loss (Proposed) = 0.396 (9) x 1240 (10) x 46 (3) = 22587 W (12)

Heat Loss (Reduction) = 38444 (11) - 22587 (12) = 15857 W (13)
 = 15857 (13) = 15.86 kW (14)
1000

ESTIMATED ENERGY COST SAVINGS PER ANNUM:

GAS: N/A

= 2.95 x _____ (5) x _____ (14) x _____ (4) = \$ _____ (15)
_____ (3)

OIL:

= 2.73 x 0.45 (6) x 15.86 (14) x 4966 (4) = \$ 2,103 (16)
_____ (3)

ELECTRICITY: N/A

= 16.8 x _____ (7) x _____ (14) x _____ (4) = \$ _____ (17)
_____ (3)

ESTIMATED COST OF IMPROVEMENT: \$ 15,000 (18)

TOTAL ESTIMATED SAVINGS PER ANNUM:

— (15) + 2,103 (16) + — (17) = \$ 2,103 (19)

SIMPLE PAYBACK = 15,000 (18) = 7.1 years
2,103 (19)

Heat Transmission — Walls
Worksheet 18-2
Page 1 of 2

Company: WORKED EXAMPE 2 Date: JAN. 22/86
 Location: RETROFIT By: MBE

DESIGN REQUIREMENTS:

Temperature inside 20 °C (1)
 Temperature outside -18 °C (2)
 (1) - (2) = 20 - (-18) = 38 °C (3)
 Degree Days below 18.0°C 4067 (4)
 (Obtain from N.B.C.)

FUEL COSTS:

(Obtain from utility bills)

Gas ----- (Cf) (\$/m³) 0.21 (5)
 Oil ----- (Cf) (\$/L) _____ (6)
 Electricity ----- (Ce) (\$/kWh) _____ (7)
 (Ignore demand charges)

**INITIAL PROPOSED
 WALL CONSTRUCTION
 "EXISTING"**

RSI = 0.572

$$U = \frac{1}{RSI} = \frac{1}{0.572} = 1.75 \text{ (8)}$$

SKETCH OR DESCRIBE "EXISTING" CONDITIONS

OUTSIDE AIR FILM	0.030
METAL SIDING	0.123
100 mm BRICK	0.074
300 mm BLOCK	0.225
INSIDE AIR FILM	0.120
	0.572

COST - \$ 13,000

**INSULATED
 WALL CONSTRUCTION
 "PROPOSED"**

RSI = 1.612

$$U = \frac{1}{RSI} = \frac{1}{1.612} = 0.62 \text{ (9)}$$

SKETCH OR DESCRIBE "PROPOSED" CONDITIONS

EXISTING WALL	0.572
INSULATION, 50 mm F.G.	1.040
	1.612

COST \$ 17,000

See Materials/Systems Section and Table 1 in Appendix B for RSI-value of various building materials.

Heat Transmission — Walls

Worksheet 18-2

Page 2 of 2

Company: WORKED EXAMPLE 2 Date: JAN. 22/06

Location: RETROFIT By: MBE

Net Wall Area (wall area minus area of all doors and windows)

Length x Width = _____ x _____ = _____ m²

Windows (sash area) (-) _____ m²

Doors (frame area) (-) _____ m²

Net Wall Area = 360 m² (10)

Heat Loss (Existing) = 1.75 (8) x 360 (10) x 38 (3) = 23,940 W (11)

Heat Loss (Proposed) = 0.62 (9) x 360 (10) x 38 (3) = _____ W (12)

Heat Loss (Reduction) = 23,940 (11) - 8,481 (12) = 15,459 W (13)
 = 15,459 (13) = 15.6 kW (14)
1000

ESTIMATED ENERGY COST SAVINGS PER ANNUM:

GAS:

= 2.95 x 0.21 (5) x 15.6 (14) x 4,067 (4) = \$ 1,034 (15)
38 (3)

OIL: N/A

= 2.73 x _____ (6) x _____ (14) x _____ (4) = \$ _____ (16)
_____ (3)

ELECTRICITY: N/A

= 16.8 x _____ (7) x _____ (14) x _____ (4) = \$ _____ (17)
_____ (3)

ESTIMATED COST OF IMPROVEMENT: (DIFFERENCE) \$ 4,000 (18)

TOTAL ESTIMATED SAVINGS PER ANNUM:

1,034 (15) + — (16) + — (17) = \$ 1,034 (19)

SIMPLE PAYBACK = 4000 (18) = 3.9 years
1,034 (19)

Heat Transmission — Walls

Worksheet 18-2

Page 1 of 2

Company: WORKED EXAMPLE 3 Date: JAN. 22/86
 Location: RETROFIT By: MBE

DESIGN REQUIREMENTS:

Temperature inside 20 °C (1)

Temperature outside -32 °C (2)

(1) - (2) = 20 - (-32) = 52 °C (3)

Degree Days below 18.0°C 5664 (4)
 (Obtain from N.B.C.)

FUEL COSTS:

(Obtain from utility bills)

Gas ----- (Cf) (\$/m³) _____ (5)

Oil ----- (Cf) (\$/L) 0.45 (6)

Electricity ----- (Ce) (\$/kWh) _____ (7)

(Ignore demand charges)

SKYLIGHT

~~WALL~~ CONSTRUCTION
 "EXISTING"

RSI = 0.155

U = $\frac{1}{RSI} = \frac{1}{0.155} = 6.45$ (8)

SKETCH OR DESCRIBE "EXISTING" CONDITIONS

OUTSIDE AIR FILM	0.030
GLASS	0.020
INSIDE AIR FILM	0.105
	0.155

~~WALL~~ CONSTRUCTION
 "PROPOSED"

RSI = 1.489

U = $\frac{1}{RSI} = \frac{1}{1.489} = 0.67$ (9)

SKETCH OR DESCRIBE "PROPOSED" CONDITIONS

ADD - 80 MM URETHANE FOAM INSULATION	1.260
- 12 mm G. W. B.	0.074
EXISTING MATERIALS	0.155
	1.489

See Materials/Systems Section and Table 1 in Appendix B for RSI-value of various building materials.

Heat Transmission — Walls

Worksheet 18-2

Page 2 of 2

Company: WORKED EXAMPLE 3 Date: JAN. 22/86

Location: RETROFIT By: MBE

Net Wall Area (wall area minus area of all doors and windows)

Length x Width = _____ x _____ = _____ m²

Windows (sash area) (-) _____ m²

Doors (frame area) (-) _____ m²

SKYLIGHT
Net Wall Area = 35 m² (10)

Heat Loss = 6.45 (8) x 35 (10) x 52 (3)
(Existing) = 11739 W (11)

Heat Loss = 0.67 (9) x 35 (10) x 52 (3)
(Proposed) = 1219 W (12)

Heat Loss = 11739 (11) - 1219 (12) = 10520 W (13)
(Reduction) = 10520 (13) = 10.5 kW (14)
1000

ESTIMATED ENERGY COST SAVINGS PER ANNUM:

GAS: N/A

= 2.95 x _____ (5) x _____ (14) x _____ (4) = \$ _____ (15)
_____ (3)

OIL:

= 2.73 x 0.45 (6) x 10.5 (14) x 5.664 (4) = \$ 1,405 (16)
52 (3)

ELECTRICITY: N/A

= 16.8 x _____ (7) x _____ (14) x _____ (4) = \$ _____ (17)
_____ (3)

ESTIMATED COST OF IMPROVEMENT: \$ 3,000 (18)

TOTAL ESTIMATED SAVINGS PER ANNUM:

— (15) + 1,405 (16) + — (17) = \$ 1,405 (19)

SIMPLE PAYBACK = 3000 (18) = 2.1 years
1,405 (19)

Heat Transmission — Walls
Worksheet 18-2
Page 1 of 2

Company: WORKED EXAMPLE 4 Date: JAN. 22/86
 Location: RETROFIT By: MBE

DESIGN REQUIREMENTS:

Temperature inside 20 °C (1)

Temperature outside -26 °C (2)

(1) - (2) = 20 - (-26) = 46 °C (3)

Degree Days below 18.0°C 4966 (4)
(Obtain from N.B.C.)

FUEL COSTS:

(Obtain from utility bills)

Gas ----- (Cf) (\$/m³) _____ (5)

Oil ----- (Cf) (\$/L) 0.45 (6)

Electricity ----- (Ce) (\$/kWh) _____ (7)
(Ignore demand charges)

**WALL CONSTRUCTION
"EXISTING"**

RSI = 1.063

U = $\frac{1}{RSI} = \underline{0.94}$ (8)

SKETCH OR DESCRIBE "EXISTING" CONDITIONS

SEE FIG. 8

**WALL CONSTRUCTION
"PROPOSED"**

RSI = 2.103

U = $\frac{1}{RSI} = \underline{0.48}$ (9)

SKETCH OR DESCRIBE "PROPOSED" CONDITIONS

SEE FIG. 9

See Materials/Systems Section and Table 1 in Appendix B for RSI-value of various building materials.

Heat Transmission — Walls

Worksheet 18-2

Page 2 of 2

Company: WORKED EXAMPLE 4 Date: JAN. 22/86

Location: RETROFIT By: MBE

Net Wall Area (wall area minus area of all doors and windows)

Length x Width = _____ x _____ = _____ m²

Windows (sash area) (-) _____ m²

Doors (frame area) (-) _____ m²

Net Wall Area = 100 m² (10)

Heat Loss (Existing) = 0.94 (8) x 100 (10) x 46 (3) = 4324 W (11)

Heat Loss (Proposed) = 0.48 (9) x 100 (10) x 46 (3) = 2209 W (12)

Heat Loss (Reduction) = 4324 (11) - 2209 (12) = 2116 W (13)
 = 2116 (13) = 2.12 kW (14)
 1000

ESTIMATED ENERGY COST SAVINGS PER ANNUM:

GAS: N/A

= 2.95 x _____ (5) x _____ (14) x _____ (4) = \$ _____ (15)
 _____ (3)

OIL:

= 2.73 x 0.45 (6) x 2.12 (14) x 4966 (4) = \$ 281 (16)
46 (3) PER 100 M²

ELECTRICITY: N/A

= 16.8 x _____ (7) x _____ (14) x _____ (4) = \$ _____ (17)
 _____ (3)

ESTIMATED COST OF IMPROVEMENT: \$ 1,600 PER 100 m² (18)

TOTAL ESTIMATED SAVINGS PER ANNUM: PER 100 m²

— (15) + 281 (16) + — (17) = \$ 281 (19)

SIMPLE PAYBACK = 1600 (18) = 5.7 years
281 (19)

Heat Transmission — Roofs

Worksheet 18-3

Page 1 of 3

Company: WORKED EXAMPLE 5

Date: JAN. 22/86

Location: RETROFIT

By: MBE

DESIGN REQUIREMENTS:

Temperature inside 20 °C (1)

Temperature outside -26 °C (2)

(1) - (2) = 20 - (-26) = 46 °C (3)

Degree Days below 18.0°C 4940 (4)
(Obtain from N.B.C.)

FUEL COSTS:

(Obtain from utility bills)

Gas ----- (Cf) (\$/m³) _____ (5)

Oil ----- (Cf) (\$/L) 0.45 (6)

Electricity ----- (Ce) (\$/kWh) _____ (7)

(Ignore demand charges)

ROOF CONSTRUCTION "EXISTING" — TYPE A

RSI = 1.279

U = $\frac{1}{RSI} = \underline{0.782}$ (8A)

SKETCH OR DESCRIBE "EXISTING" CONDITIONS AREA 1400 m² (9)

OUTSIDE AIR FILM	0.030
ROOFING	0.026
12 mm FIBER BOARD	0.233
100 mm FACTORY DECK	0.870
INSIDE AIR FILM	0.120
	1.279

ROOF CONSTRUCTION "EXISTING" — TYPE B

RSI = 0.585

U = $\frac{1}{RSI} = \underline{1.709}$ (8B)

SKETCH OR DESCRIBE "EXISTING" CONDITIONS AREA 570 m² (10)

OUTSIDE AIR FILM	0.030
METAL FLASHING	NEGL.
47 mm WOOD	0.435
INSIDE AIR FILM	0.120
	0.585

See Materials/Systems Section and Table 1 in Appendix B for RSI-value of various building materials.

Heat Transmission — Roofs

Worksheet 18-3

Page 2 of 3

Company: WORKED EXAMPLE 5 Date: JAN. 22/86

Location: RETROFIT By: MBE

ROOF CONSTRUCTION
"REVISED" — TYPE A

SKETCH OR DESCRIBE PROPOSED CHANGES

$$RSI = \underline{2.539}$$

ADD 30 mm URETHANE
FOAM (RSI = 1.26)
1.26 + 1.279

$$U = \frac{1}{RSI} = \underline{0.394} \text{ (11A)}$$

ROOF CONSTRUCTION
"PROPOSED" — TYPE B

SKETCH OR DESCRIBE PROPOSED CHANGES

$$RSI = \underline{1.845}$$

ADD 30 mm URETHANE FOAM
1.26 + 0.585 = 1.845

$$U = \frac{1}{RSI} = \underline{0.542} \text{ (11B)}$$

ENERGY SAVINGS — TYPE A

$$\begin{aligned} \text{Heat Loss (Existing)} &= \underline{0.782} \text{ (8A)} \times \underline{1400} \text{ (9)} \times \underline{46} \text{ (3)} \\ &= \underline{51455} \text{ W (12)} \end{aligned}$$

$$\begin{aligned} \text{Heat Loss (Proposed)} &= \underline{0.394} \text{ (11A)} \times \underline{1400} \text{ (9)} \times \underline{46} \text{ (3)} \\ &= \underline{25373} \text{ W (13)} \end{aligned}$$

$$\begin{aligned} \text{Heat Loss (Savings)} &= \underline{51455} \text{ (12)} - \underline{25373} \text{ (13)} = \underline{26082} \text{ W (14)} \\ &= \frac{\underline{26082}}{1000} \text{ (14)} = \underline{26.08} \text{ kW (15)} \end{aligned}$$

ENERGY SAVINGS — TYPE B

$$\begin{aligned} \text{Heat Loss (Existing)} &= \underline{1.709} \text{ (8B)} \times \underline{570} \text{ (10)} \times \underline{46} \text{ (3)} \\ &= \underline{44800} \text{ W (11)} \end{aligned}$$

$$\begin{aligned} \text{Heat Loss (Proposed)} &= \underline{0.542} \text{ (11B)} \times \underline{570} \text{ (10)} \times \underline{46} \text{ (3)} \\ &= \underline{14211} \text{ W (17)} \end{aligned}$$

$$\begin{aligned} \text{Heat Loss (Savings)} &= \underline{44800} \text{ (16)} - \underline{14211} \text{ (17)} = \underline{30589} \text{ W (18)} \\ &= \frac{\underline{30589}}{1000} \text{ (18)} = \underline{30.59} \text{ kW (19)} \end{aligned}$$

$$\text{ENERGY SAVINGS - TOTAL} = \underline{26.08} \text{ (15)} + \underline{30.59} \text{ (19)} = \underline{56.67} \text{ (20)}$$

Heat Transmission — Roofs
Worksheet 18-3
Page 3 of 3

Company: WORKED EXAMPLES Date: JAN. 22/86
 Location: RETROFIT By: MBE

ESTIMATED ENERGY COST SAVINGS PER ANNUM:

GAS: N/A

$$= 2.95 \times \text{_____} (5) \times \text{_____} (20) \times \text{_____} (4) = \$ \text{_____} (21)$$

_____ (3)

OIL:

$$= 2.73 \times \underline{0.45} (6) \times \underline{56.67} (20) \times \underline{49.66} (4) = \$ \underline{7516} (22)$$

_____ (3)

ELECTRICITY: N/A

$$= 16.8 \times \text{_____} (7) \times \text{_____} (20) \times \text{_____} (4) = \$ \text{_____} (23)$$

_____ (3)

ESTIMATED COST OF IMPROVEMENT: \$ 39,400 (24)

TOTAL ESTIMATED SAVINGS PER ANNUM:

$$\text{_____} (21) + \underline{7516} (22) + \text{_____} (23) = \$ \underline{7516} (25)$$

SIMPLE PAYBACK = $\frac{\underline{39400} (24)}{\underline{7516} (25)} = \underline{5.2} \text{ years}$

APPENDICES

- A Glossary of Terms**
- B Tables**
- C Common Conversions**
- D Worksheets**
- E Bibliography**

Glossary

Air Barrier — Materials such as building paper, plywood sheathing, structural wall, vapor barrier or drywall which prevent air movement.

As-built — Refers to drawings made after construction of a building to record the final construction details.

ASHRAE — The American Society of Heating, Refrigerating and Air-Conditioning Engineers, Inc., 1791 Tullie Circle, N.E., Atlanta, Georgia, 30329, U.S.A.

Berm — Mounds of earth used in the design of landscaping as well as for insulating purposes when constructed against a retaining wall of a building.

Building Envelope — The shell of a building consisting of roof, walls, windows, doors and floors.

Caulking — A semiliquid sealer material which is applied to joints and gaps between building components.

Condensation — The process by which water vapor in the air assumes a liquid form when cooled.

Conduction — A form of heat transfer where thermal energy (heat) is transported through a material from the warmer to the cooler side. Rate of flow varies with material properties and temperature difference. See Thermal Conductivity and Convection.

Construction Joint — A flexible joint between sections of material, such as concrete or brick, used to control cracking and prevent air infiltration.

Convection — A form of heat (thermal energy) transfer in fluids by the mixing and diffusion of the warmer fluid with a cooler fluid.

Curtain Wall — A system of glazing held in place by metal mullions commonly employed as a continuous system on the exterior of high rise buildings, in which the large sheets of glass are hung by their upper edge.

Degree Day - Heating — A measure to correlate the outside temperature with the energy required for heating based on the assumption that heating is required when the average daily temperature is less than 18°C. Thus, one heating Degree Day results from an average temperature of 17°C for 24 hours. The Degree Days are accumulated to provide a means of comparing the influence of weather on energy usage over a period of time.

Dew Point — The temperature level at which water vapor will condense for a given relative humidity (R.H.); a lower R.H. results in a lower dew point temperature.

Dock Seal — Cushioning components installed around a loading bay opening. A truck backs against the cushion to provide a seal between the truck and building.

Dock Shelter — Contact panels that wrap around a vehicle to seal a loading dock opening.

Door Closer — A pneumatic device which closes a door smoothly and completely.

Exfiltration — The uncontrolled outward air leakage through building cracks and openings such as those normally found around windows and doors. It is caused by the pressure effects of wind and/or the effect of differences in the indoor and outdoor air densities.

F.G. Insulation — Fiberglass building insulation.

HVAC — Heating, ventilating and air-conditioning.

Infiltration — The uncontrolled inward air leakage through cracks in any building element and around windows and doors of a building, caused by the pressure effects of wind and/or the effect of differences in the indoor and outdoor air density.

Insulation — Insulation is a material of low thermal conductivity used to reduce the flow of heat through a component.

Louvers — Slotted openings which cover mechanical openings or windows and allow the passage of light or air.

Orientation — The relationship of a building to compass directions.

Prevailing Wind — The wind direction that occurs most of the time at a particular site.

Radiation — The type of heat transfer that occurs by electromagnetic waves from a warmer to a cooler surface. It is transferred directly and is not affected by the cool temperature of the surrounding air.

Rain Screen — A construction method in which the exterior cladding may be penetrated by moisture, which is then shed by a moisture proof membrane within the wall cavity, draining through weepholes at the bottom over through-wall flashing, keeping the interior structural wall dry.

Reflective Film — A coating applied to glass either in the manufacturing process or to an existing window which reduces solar gain by changing the reflecting and heat absorbing characteristics.

Relative Humidity — A measure of the amount of water vapor in the air as a percentage of the amount of vapor the air can hold at a given temperature. Thus 30% R.H. indicates that the air contains 30% of the moisture it is capable of holding. As the temperature drops with a constant amount of water in the air, the R.H. rises until it reaches 100% after which condensation occurs. This temperature is the dew point.

Simple Payback — Refers to the time it will take for a building improvement to be paid for by the related annual energy savings generated.

Stack Effect — The effect of warm air gradually rising through a high building to the top where a positive pressure area is created, with a corresponding negative pressure at the lower floors. These conditions can reverse in summer when the outside temperature is higher than the inside. Stack effect is a cause of air infiltration and exfiltration.

Temperature Gradient — The rate of change of the temperature through a building material according to the thermal resistance.

Test Cut — A small opening made in the building envelope to determine the construction.

Thermal Conductivity (k) — Thermal conductivity is a measure of the heat energy transmitted through a homogeneous material *per unit of thickness*. Units are expressed as $W/(m^2 \cdot ^\circ C)$.

Thermal Resistance (RSI) — Thermal resistance is a number indicating the relative insulating value or resistance to heat flow of a material or assembly. Units are expressed as $(m^2 \cdot ^\circ C)/W$. Note: $RSI = 1/U$

Thermal Transmittance (U) — Thermal transmittance is a measure of the heat energy transmitted by a material or assembly including the boundary films. Units are expressed as $W/(m^2 \cdot ^\circ C)$. Note $U = 1/RSI$

Thermal Unit — Refers to a factory sealed construction of double or triple glazed window pane.

Thermography, Thermographic Analysis — A process of infrared photography which shows by colour patterns, precise areas of heat loss and roof leaks.

Topography — A general term referring to variations in land elevations including hills, knolls, ravines, valleys and mountains.

Vapor Barrier — Membrane impervious to the passage of water vapor such as polyethylene, foil, or sheet metal, installed continuously within the building envelope on the warm side of the insulation to prevent flow of vapor into the insulation where it may condense.

Vestibule — A small enclosure at a doorway, through which it is necessary to pass in order to enter the building. It should be large enough for one set of doors to close before the other is opened.

Weather-stripping — A flexible sealing strip applied to the frame of a door or window frame, against which the door or window closes.

**VALUES OF THERMAL RESISTANCE (RSI)
OF
VARIOUS BUILDING MATERIALS
(m²·°C/W)**

TABLE 1
Page 1 of 3

Description	Per mm Thickness	For Listed Thickness
SHEATHING MATERIALS		
Softwood Plywood	0.0087	
Mat-formed Particle Board	0.0087	
Insulating Fiberboard Sheathing	0.0165	
Gypsum Sheathing	0.0062	
Sheathing Paper		0.011
Asphalt Coated Kraft Paper		
Vapor Barrier		Negligible
Polyethylene Vapor Barrier		Negligible
CLADDING MATERIALS		
Fiberboard Siding	0.0107	
Softwood Siding		
— Drop — 18 x 184 mm		0.139
— Bevel — 12 x 184 mm — Lapped		0.143
— Bevel — 19 x 235 mm — Lapped		0.185
— Plywood — 9 mm— Lapped		0.103
Brick		
— Clay or Shale — 100 mm		0.074
— Concrete and Sand/Lime — 100 mm		0.053
Stucco	0.0014	
Metal Siding		
— Horizontal Clapboard Profile		0.123
— Horizontal Clapboard Profile with backing		0.246
— Vertical V-Groove Profile		0.123
— Vertical Board and Batten Profile		Negligible
ROOFING MATERIALS		
Asphalt Roll Roofing		0.026
Asphalt Shingles		0.078
Built-up Roofing		0.058
Wood Shingles		0.165
Crushed Stone — Not Dried	0.0006	

**VALUES OF THERMAL RESISTANCE (RSI)
OF
VARIOUS BUILDING MATERIALS
(m²·°C/W)**

TABLE 1
Page 2 of 3

Description	Per mm Thickness	For Listed Thickness
INSULATION		
Mineral Wool and Glass Fiber	0.0208	
Cellulose Fiber	0.0253	
Vermiculite	0.0144	
Wood Shavings	0.0169	
Sprayed Asbestos	0.0201	
Expanded Polystyrene Complying with CGSB 41-GP-14a (1972)		
— Type 1	0.0257	
— Type 2	0.0277	
— Type 3	0.0298	
— Type 4	0.0347	
Rigid Glass Fiber Roof Insulation	0.0277	
Natural Cork	0.0257	
Rigid Urethane or Isocynuarate Board	0.0420	
Mineral Aggregate Board	0.0182	
Compressed Straw Board	0.0139	
Fiberboard	0.0194	
STRUCTURAL MATERIALS		
Cedar Logs and Lumber	0.0092	
Other Softwood Logs and Lumber	0.0087	
Concrete — 2400 kg/m ³	0.00045	
— 1700 kg/m ³	0.0013	
— 480 kg/m ³	0.0069	
Concrete Block — 3 Oval Core — Sand and Gravel Aggregate		
(or Cinder Aggregate)		
— 100 mm		0.125
— 200 mm		0.195
— 300 mm		0.225
Lightweight Aggregate		
— 100 mm		0.264
— 200 mm		0.352
— 300 mm		0.400
INTERIOR FINISH MATERIALS		
Gypsum Board, Gypsum Lath	0.0062	
Gypsum Plaster — Sand Aggregate	0.0014	
Gypsum Plaster — Lightweight Aggregate	0.0044	
Plywood	0.0087	
Hard-Pressed Fiberboard	0.0050	
Insulating Fiberboard	0.0165	
Mat-formed Particleboard	0.0165	
Carpet & Fibrous Underlay		0.366
Carpet & Rubber Underlay		0.226
Resilient Floor Coverings		0.014
Terrazzo — 25 mm		0.014
Hardwood Flooring — 9.5 mm		0.060
— 19 mm		0.060
Wood Fiber Tiles — 13 mm		0.209

**VALUES OF THERMAL RESISTANCE (RSI)
OF
VARIOUS BUILDING MATERIALS
(m²·°C/W)
TABLE 1
Page 3 of 3**

Description	Per mm Thickness	For Listed Thickness
AIR SURFACE FILMS		
Still Air — Horizontal Surface		
— Heat Flow Up		0.105
— Heat Flow Down		0.162
Still Air — Vertical Surface		
— Heat Flow Horizontal		0.120
Moving Air — Any Position		0.030
AIR SPACES — FACED WITH NONREFLECTIVE MATERIALS (12mm — Minimum Dimension)		
Horizontal Space		
— Heat Flow Up		0.150
— Heat Flow Down		0.180
Vertical Space		
— Heat Flow Horizontal		0.171
Air Spaces Less than 12 mm in Minimum Dimension		Negligible
Horizontal Space-Faced 1 Side		
— Heat Flow Up		0.324
— Heat Flow Down		0.980
Horizontal Space-Faced 2 Sides		
— Heat Flow Up		0.332
— Heat Flow Down		1.034
Vertical Space-Faced 1 Side		
— Heat Flow Horizontal		0.465
Vertical Space-Faced 2 Sides		
— Heat Flow Horizontal		0.480
Air Spaces Less Than 12 mm in Minimum Dimension		Negligible
GLASS		
— 6 mm plate		0.020

DESIGN DATA FOR SELECTED LOCATIONS IN CANADA TABLE 2

Note: This is a typical data sheet from "Climatic Data" of the National Building Code. Refer to the Code for other locations.

Province and Location	Design Temperature				Degree-Days Below 18°C	15 Min. Rain. mm	One Day Rain. mm	Ann. Tot. Pcpn. mm	Gnd. Snow Load. kPa	Hourly Wind Pressures			Seismic Data		
	January		July 2½%							1/10. kPa	1/30. kPa	1/100. kPa	Z _a	Z _b	Zonal velocity ratio. v
	2½% °C	1% °C	Dry. °C	Wet. °C											
Hamilton	-17	-19	31	23	3827	23	117	799	1.6	0.36	0.43	0.50	1	0	0.05
Hanover	-19	-21	30	22	4340	28	76	877	3.6	0.34	0.43	0.54	1	0	0.05
Hastings	-23	-26	30	23	4400	28	89	790	2.7	0.29	0.37	0.47	1	1	0.05
Hawkesbury	-25	-27	30	23	4800	23	89	961	3.0	0.31	0.37	0.45	4	2	0.10
Hearst	-34	-36	28	21	6500	20	63	846	2.9	0.20	0.25	0.32	0	0	0.00
Honey Harbour	-24	-26	29	22	4400	23	127	950	3.8	0.25	0.34	0.45	1	1	0.05
Hornepayne	-37	-40	28	21	6545	20	83	734	2.7	0.19	0.25	0.31	0	0	0.00
Huntsville	-26	-29	29	22	4780	25	104	971	4.0	0.19	0.25	0.33	1	1	0.05
Ingersoll	-18	-20	30	23	4000	28	89	890	2.0	0.33	0.43	0.54	0	0	0.00
Iroquois Falls	-33	-36	29	21	6200	20	63	780	3.4	0.30	0.37	0.45	1	0	0.05
Jarvis	-16	-18	30	23	3875	28	102	850	1.7	0.33	0.39	0.47	1	0	0.05
Jellicoe	-36	-39	28	21	6600	20	76	710	3.5	0.21	0.25	0.29	0	0	0.00
Kapuskasing	-33	-35	28	21	6438	20	80	858	2.9	0.23	0.28	0.34	0	0	0.00
Kemptville	-25	-27	30	23	4622	25	73	867	2.7	0.30	0.37	0.46	4	2	0.10
Kenora	-33	-36	28	22	5938	25	128	623	3.1	0.20	0.24	0.28	0	0	0.00
Killaloe	-28	-31	30	22	5082	23	62	674	2.8	0.24	0.29	0.36	3	1	0.05
Kincardine	-17	-19	28	22	4100	23	76	890	3.7	0.40	0.50	0.62	0	0	0.00
Kingston	-22	-24	27	23	4251	23	119	870	2.2	0.35	0.43	0.52	2	1	0.05
Kinmount	-26	-28	29	22	4800	25	102	950	3.1	0.20	0.26	0.34	1	1	0.05
Kirkland Lake	-33	-36	30	21	6113	20	97	856	3.3	0.29	0.37	0.46	1	1	0.05
Kitchener	-19	-21	29	23	4146	28	175	897	2.9	0.27	0.34	0.42	1	0	0.05
Lakefield	-24	-26	30	23	4550	28	89	770	2.9	0.27	0.34	0.43	1	1	0.05
Lansdowne House	-39	-41	28	21	7199	18	78	666	3.2	0.24	0.29	0.35	0	0	0.00
Leamington	-15	-17	31	24	3556	28	106	816	1.1	0.35	0.43	0.52	0	0	0.00
Lindsay	-24	-26	30	23	4513	25	97	856	2.7	0.26	0.34	0.43	1	1	0.05
Lions Head	-19	-21	27	22	4490	25	76	890	3.3	0.33	0.43	0.54	1	0	0.00
Listowel	-19	-21	29	23	4811	30	144	951	3.8	0.34	0.43	0.53	1	0	0.05
London	-18	-20	30	23	4133	28	83	909	1.9	0.36	0.48	0.61	0	0	0.00
Lucan	-17	-19	30	23	4150	25	118	927	2.0	0.39	0.50	0.63	0	0	0.00
Maitland	-23	-25	29	23	4200	25	76	960	2.4	0.32	0.39	0.49	3	1	0.05
Markdale	-20	-22	29	22	4700	28	76	1030	4.0	0.29	0.37	0.47	1	0	0.05
Martin	-36	-39	29	22	6248	25	114	751	3.2	0.21	0.25	0.29	0	0	0.00
Matheson	-33	-36	29	21	6250	20	76	830	3.4	0.30	0.37	0.46	1	1	0.05
Mattawa	-29	-31	30	22	5300	23	89	830	2.7	0.24	0.29	0.35	3	1	0.05
Midland	-23	-26	29	22	4257	25	96	1035	3.8	0.25	0.34	0.45	1	1	0.05
Milton	-18	-20	30	23	4138	25	127	875	2.2	0.32	0.39	0.48	1	0	0.05
Milverton	-19	-21	29	23	4550	30	76	980	3.4	0.31	0.39	0.49	1	0	0.05
Minden	-26	-29	29	22	4967	25	94	971	3.2	0.19	0.25	0.31	1	1	0.05
Mississauga	-18	-20	30	23	4000	25	140	760	1.8	0.37	0.45	0.55	1	0	0.05
Mitchell	-18	-20	29	23	4519	28	72	840	3.0	0.35	0.45	0.57	0	0	0.00
Monson	-36	-38	28	21	7011	18	63	728	2.8	0.19	0.24	0.29	0	0	0.00
Morrisburg	-23	-25	30	23	4550	25	114	928	2.5	0.30	0.37	0.46	4	2	0.10
Mount Forest	-21	-23	29	22	4694	30	84	964	4.0	0.29	0.37	0.47	1	0	0.05
Muskoka Airport	-26	-28	29	22	4911	25	115	1009	3.1	0.19	0.25	0.33	1	1	0.05
Nakina	-35	-37	28	21	6816	20	70	811	3.1	0.20	0.24	0.28	0	0	0.00
Napanee	-22	-24	28	23	4150	23	89	870	2.2	0.32	0.39	0.48	2	1	0.05
Newcastle	-20	-22	30	23	4200	23	76	810	2.1	0.46	0.55	0.65	1	1	0.05
New Liskeard	-32	-35	30	21	5664	23	82	749	3.2	0.31	0.39	0.49	2	1	0.05
Newmarket	-22	-24	30	23	4395	28	102	797	2.4	0.26	0.34	0.44	1	1	0.05
Niagara Falls	-16	-18	30	23	3662	23	95	942	2.0	0.33	0.39	0.47	2	0	0.05
North Bay	-28	-30	28	21	4990	28	96	930	2.7	0.26	0.31	0.37	2	1	0.05
Norwood	-24	-26	30	23	4531	28	89	785	2.8	0.29	0.37	0.47	1	1	0.05
Onkville	-18	-20	30	23	3915	23	74	799	1.7	0.37	0.45	0.54	1	0	0.05
Orangeville	-21	-23	29	23	4775	30	101	789	3.6	0.25	0.32	0.41	1	0	0.05
Oroville	-25	-27	29	22	4690	25	147	907	2.5	0.19	0.26	0.35	1	1	0.05
Oshawa	-19	-21	30	23	3968	23	76	864	2.1	0.43	0.52	0.64	1	1	0.05
Ottawa	-25	-27	30	23	4634	23	93	846	2.9	0.30	0.37	0.46	4	2	0.10
Owen Sound	-19	-21	29	22	4236	28	138	1024	3.8	0.33	0.43	0.55	1	0	0.05
Pegwa River	-34	-36	28	21	6595	20	80	902	3.2	0.19	0.25	0.31	0	0	0.00
Peris	-17	-19	30	23	4025	23	89	860	2.2	0.31	0.37	0.45	1	0	0.05
Perth	-16	-18	31	23	3900	23	89	860	1.9	0.40	0.50	0.61	0	0	0.00
Perry Sound	-24	-26	28	21	4730	23	123	1094	3.6	0.24	0.34	0.46	1	1	0.05
Perth	-28	-31	30	22	4873	23	103	770	2.6	0.22	0.26	0.32	4	2	0.10
Perth	-23	-26	29	22	4275	25	127	1025	3.8	0.25	0.34	0.45	1	1	0.05
Perth	-25	-27	30	23	4650	25	76	920	2.8	0.29	0.37	0.46	3	1	0.05
Peterborough	-29	-31	30	23	5160	23	119	800	2.6	0.19	0.24	0.29	4	2	0.10
Peterborough	-23	-25	30	23	4411	28	87	793	2.8	0.29	0.37	0.47	1	1	0.05
Petrolia	-16	-18	31	24	3824	25	76	873	1.6	0.35	0.43	0.52	0	0	0.00
Pictou	-21	-23	29	23	3999	23	76	947	2.0	0.37	0.45	0.54	1	1	0.05
Pittsville	-18	-20	29	23	4150	28	89	920	2.8	0.30	0.37	0.46	1	0	0.05
Point Alexander	-29	-32	30	22	5150	23	89	790	2.6	0.20	0.24	0.28	4	2	0.10
Columbus 1	2	3	4	5	6	7	8	9	10	11	12	13	14	15	16

**INFILTRATION THROUGH WINDOWS AND DOORS
CRACK METHOD — SUMMER — WINTER
TABLE 3**

DOUBLE HUNG WINDOWS — UNLOCKED ON WINDWARD SIDE NOTE: W-STRIP DENOTES WEATHERSTRIP

TYPE OF DOUBLE HUNG WINDOW	L/s PER LINEAR METER OF CRACK											
	WIND VELOCITY m/s											
	2.24		4.47		6.70		8.94		11.17		13.41	
	No W-Strip	W-Strip	No W-Strip	W-Strip	No W-Strip	W-Strip	No W-Strip	W-Strip	No W-Strip	W-Strip	No W-Strip	W-Strip
Wood Sash												
Average Window	.19	.11	.54	.34	1.01	.62	1.52	.93	2.06	1.27	2.68	1.63
Poorly Fitted Window	.70	.15	1.78	.50	2.86	.88	4.03	1.32	.01	1.83	6.50	.37
Poorly Fitted — with Storm Sash	.36	.08	.88	.25	1.44	.45	2.01	.67	2.48	.91	3.25	1.18
Metal Sash	.51	.15	1.21	.50	1.90	.82	2.68	1.19	3.56	1.55	4.34	1.97

CASEMENT TYPE WINDOWS ON WINDWARD SIDE

TYPE OF CASEMENT WINDOW AND TYPICAL CRACK SIZE mm	L/s PER LINEAR METER OF CRACK						
	WIND VELOCITY m/s						
	2.24	4.47	6.70	8.94	11.17	13.41	
Rolled Section-Steel Sash							
Industrial Pivoted 1.6 crack	1.35	2.79	4.49	6.35	7.90	9.60	
Architectural Projected 0.8 crack	.39	.93	1.60	2.21	2.88	3.56	
Architectural Projected 1.2 crack	.51	1.35	2.28	2.99	3.87	4.65	
Residential Casement 0.4 crack	.15	.46	.85	1.21	1.55	1.90	
Residential Casement 0.8 crack	.36	.82	1.35	1.97	2.59	3.25	
Heavy Casement Section Projected 0.4 crack	.08	.26	.46	.67	.90	1.24	
Heavy Casement Section Projected 0.8 crack	.20	.62	.98	1.39	1.86	2.37	
Hollow Metal-Vertically Pivoted	.77	2.26	3.72	4.80	5.73	6.19	

DOORS ON WINDWARD SIDE

TYPE OF DOOR	L/s PER LINEAR METER OF CRACK						
	WIND VELOCITY m/s						
	2.24	4.47	6.70	8.94	11.17	13.41	
Glass Door-Herculite							
Good Installation 3.2 crack	5.0	9.9	14.9	20.1	24.8	29.4	
Average Installation 4.8 crack	7.4	15.5	21.7	31.0	37.2	44.9	
Poor Installation 6.4 crack	9.9	20.1	29.4	40.3	40.3	58.8	
Ordinary Wood or Metal							
Well Fitted W-Strip	.70	.93	1.4	2.0	2.6	3.3	
Well Fitted No W-Strip	1.4	1.9	2.8	4.0	5.1	6.5	
Poorly Fitted No W-Strip	1.4	3.6	5.7	8.1	10.2	13.0	
Factory Door 3.2 crack	5.0	9.9	14.9	20.1	24.8	29.4	

COMMON CONVERSIONS

1 barrel (35 Imp gal) (42 US gal)	= 159.1 litres	1 kilowatt	= 3600 kilojoules
1 gallon (Imp)	= 1.20094 gallon (US)	1 Newton	= 1 kg-m/s ²
1 horsepower (boiler)	= 9809.6 watts	1 therm	= 10 ⁵ Btu
1 horsepower	= 2545 Btu/hour	1 ton (refrigerant)	= 12002.84 Btu/hour
1 horsepower	= 0.746 kilowatts	1 ton (refrigerant)	= 3516.8 watts
1 joule	= 1 N-m	1 watt	= 1 joule/second
Kelvin	= (°C + 273.15)	Rankine	= (°F + 459.67)

Cubes

1 yd ³	= 27 ft ³
1 ft ³	= 1728 in ³
1 cm ³	= 1000 mm ³
1 m ³	= 10 ⁶ cm ³
1 m ³	= 1000 L

Squares

1 yd ²	= 9 ft ²
1 ft ²	= 144 in ²
1 cm ²	= 100 mm ²
1 m ²	= 10000 cm ²

SI PREFIXES

Prefix	Symbol	Magnitude	Factor
tera	T	1 000 000 000 000	10 ¹²
giga	G	1 000 000 000	10 ⁹
mega	M	1 000 000	10 ⁶
kilo	k	1 000	10 ³
hecto	h	100	10 ²
deca	da	10	10 ¹
deci	d	0.1	10 ⁻¹
centi	c	0.01	10 ⁻²
milli	m	0.001	10 ⁻³
micro	u	0.000 001	10 ⁻⁶
nano	n	0.000 000 001	10 ⁻⁹
pica	p	0.000 000 000 001	10 ⁻¹²

UNIT CONVERSION TABLES

METRIC TO IMPERIAL

FROM	SYMBOL	TO	SYMBOL	MULTIPLY BY
amperes/square centimetre	A/cm ²	amperes/square inch	A/in ²	6.452
Celsius	°C	Fahrenheit	°F	(°C × 9/5) + 32
centimetres	cm	inches	in	0.3937
cubic centimetres	cm ³	cubic inches	in ³	0.06102
cubic metres	m ³	cubic foot	ft ³	35.314
grams	g	ounces	oz	0.03527
grams	g	pounds	lb	0.0022
grams/litre	g/L	pounds/cubic foot	lb/ft ³	0.06243
joules	J	Btu	Btu	9.480 × 10 ⁻⁴
joules	J	foot-pounds	ft-lb	0.7376
joules	J	horsepower-hours	hp-h	3.73 × 10 ⁻⁷
joules/metre, (Newtons)	J/m, N	pounds	lb	0.2248
kilograms	kg	pounds	lb	2.205
kilograms	kg	tons (long)	ton	9.842 × 10 ⁻⁴
kilograms	kg	tons (short)	tn	1.102 × 10 ⁻³
kilometres	km	miles (statute)	mi	0.6214
kilopascals	kPa	atmospheres	atm	9.87 × 10 ⁻³
kilopascals	kPa	inches of mercury (@ 32°F)	in Hg	0.2953
kilopascals	kPa	inches of water (@ 4°C)	in H ₂ O	4.0147
kilopascals	kPa	pounds/square inch	psi	0.1450
kilowatts	kW	foot-pounds/second	ft-lb/s	737.6
kilowatts	kW	horsepower	hp	1.341
kilowatt-hours	kWh	Btu	Btu	3413
litres	L	cubic foot	ft ³	0.03531
litres	L	gallons (Imp)	gal (Imp)	0.21998
litres	L	gallons (US)	gal (US)	0.2642
litres/second	L/s	cubic foot/minute	cfm	2.1186
lumen/square metre	lm/m ²	lumen/square foot	lm/ft ²	0.09290
lux, lumen/square metre	lx, lm/m ²	footcandles	fc	0.09290
metres	m	foot	ft	3.281
metres	m	yard	yd	1.09361
parts per million	ppm	grains/gallon (Imp)	gr/gal (Imp)	0.07
parts per million	ppm	grains/gallon (US)	gr/gal (US)	0.05842
permeance (metric)	PERM	permeance (Imp)	perm	0.01748
square centimetres	cm ²	square inches	in ²	0.1550
square metres	m ²	square foot	ft ²	10.764
square metres	m ²	square yards	yd ²	1.196
tonne (metric)	t	pounds	lb	2204.6
watt	W	Btu/hour	Btu/h	3.413
watt	W	lumen	lm	668.45

UNIT CONVERSION TABLES

IMPERIAL TO METRIC

FROM	SYMBOL	TO	SYMBOL	MULTIPLY BY
ampere/in ²	A/in ²	ampere/cm ²	A/cm ²	0.1550
atmospheres	atm	kilopascals	kPa	101.325
British Thermal Unit	Btu	joules	J	1054.8
Btu	Btu	kilogram-metre	kg-m	107.56
Btu	Btu	kilowatt-hour	kWh	2.928×10^{-4}
Btu/hour	Btu/h	watt	W	0.2931
calorie, gram	cal or g-cal	joules	J	4.186
chain	chain	metre	m	20.11684
cubic foot	ft ³	cubic metre	m ³	0.02832
cubic foot	ft ³	litre	L	28.32
cubic foot/minute	cfm	litre/second	L/s	0.47195
cycle/second	c/s	Hertz	Hz	1.00
Fahrenheit	°F	Celsius	°C	(°F-32)/1.8
foot	ft	metre	m	0.3048
footcandle	fc	lux, lumen/ square metre	lx, lm/m ²	10.764
footlambert	fL	candela/square metre	cd/m ²	3.42626
foot-pounds	ft-lb	joule	J	1.356
foot-pounds	ft-lb	kilogram-metres	kg-m	0.1383
foot-pounds/second	ft-lb/s	kilowatt	kW	1.356×10^{-3}
gallons (Imp)	gal (Imp)	litres	L	4.546
gallons (US)	gal (US)	litres	L	3.785
grains/gallon (Imp)	gr/gal (Imp)	parts per million	ppm	14.286
grains/gallon (US)	gr/gal (US)	parts per million	ppm	17.118
horsepower	hp	watts	W	745.7
horsepower-hours	hp-h	joules	J	2.684×10^6
inches	in	centimetres	cm	2.540
inches of Mercury (@ 32°F)	in Hg	kilopascals	kPa	3.386
inches of water (@ 4°C)	in H ₂ O	kilopascals	kPa	0.2491

UNIT CONVERSION TABLES

IMPERIAL TO METRIC (cont'd)

FROM	SYMBOL	TO	SYMBOL	MULTIPLY BY
lamberts	* L	candela/square metre	cd/m ²	3.183
lumen/square foot	lm/ft ²	lumen/square metre	lm/m ²	10.76
lumen	lm	watt	W	0.001496
miles (statute)	mi	kilometres	km	1.6093
ounces	oz	grams	g	28.35
perm (at 0°C)	perm	kilogram per pascal-second-square metre	kg/Pa-s-m ² (PERM)	5.721 × 10 ⁻¹¹
perm (at 23°C)	perm	kilogram per pascal-second-square metre	kg/Pa-s-m ² (PERM)	5.745 × 10 ⁻¹¹
perm-inch (at 0°C)	perm. in.	kilogram per pascal-second-metre	kg/Pa-s-m	1.4532 × 10 ⁻¹²
perm-inch (at 23°C)	perm. in.	kilogram per pascal-second-metre	kg/Pa-s-m	1.4593 × 10 ⁻¹²
pint (Imp)	pt	litre	L	0.56826
pounds	lb	grams	g	453.5924
pounds	lb	joules/metre, (Newtons)	J/m, N	4.448
pounds	lb	kilograms	kg	0.4536
pounds	lb	tonne (metric)	t	4.536 × 10 ⁻⁴
pounds/cubic foot	lb/ft ³	grams/litre	g/L	16.02
pounds/square inch	psi	kilopascals	kPa	6.89476
quarts	qt	litres	L	1.1365
slug	slug	kilograms	kg	14.5939
square foot	ft ²	square metre	m ²	0.09290
square inches	in ²	square centimetres	cm ²	6.452
square yards	yd ²	square metres	m ²	0.83613
tons (long)	ton	kilograms	kg	1016
tons (short)	tn	kilograms	kg	907.185
yards	yd	metres	m	0.9144

* "L" as used in Lighting

4138T/T33(-2)

The following typical values for conversion factors may be used when actual data are unavailable. The MJ and Btu equivalencies are heats of combustion. Hydrocarbons are shown at the higher heating value, wet basis. Some items listed are typically feedstocks, but are included for completeness and as a reference source. The conversion factors for coal are approximate since the heating value of a specific coal is dependent on the particular mine from which it is obtained.

Consistent factors must be used when calculating Base Year and Current Year energy usage.

ENERGY TYPE	METRIC	IMPERIAL
COAL		
— metallurgical	29,000 megajoules/tonne	25.0×10^6 Btu/ton
— anthracite	30,000 megajoules/tonne	25.8×10^6 Btu/ton
— bituminous	32,100 megajoules/tonne	27.6×10^6 Btu/ton
— sub-bituminous	22,100 megajoules/tonne	19.0×10^6 Btu/ton
— lignite	16,700 megajoules/tonne	14.4×10^6 Btu/ton
COKE		
— metallurgical	30,200 megajoules/tonne	26.0×10^6 Btu/ton
— petroleum		
— raw	23,300 megajoules/tonne	20.0×10^6 Btu/ton
— calcined	32,600 megajoules/tonne	28.0×10^6 Btu/ton
PITCH	37,200 megajoules/tonne	32.0×10^6 Btu/ton
CRUDE OIL	38.5 megajoules/litre	5.8×10^6 Btu/bbl
No. 2 OIL	38.68 megajoules/litre	5.88×10^6 Btu/bbl $.168 \times 10^6$ Btu/IG
No. 4 OIL	40.1 megajoules/litre	6.04×10^6 Btu/bbl $.173 \times 10^6$ Btu/IG
No. 6 OIL (RESID. BUNKER C)		
@ 2.5% sulphur	42.3 megajoules/litre	6.38×10^6 Btu/bbl $.182 \times 10^6$ Btu/IG
@ 1.0% sulphur	40.5 megajoules/litre	6.11×10^6 Btu/bbl $.174 \times 10^6$ Btu/IG
@ .5% sulphur	40.2 megajoules/litre	6.05×10^6 Btu/bbl $.173 \times 10^6$ Btu/IG
KEROSENE	37.68 megajoules/litre	$.167 \times 10^6$ Btu/IG
DIESEL FUEL	38.68 megajoules/litre	$.172 \times 10^6$ Btu/IG
GASOLINE	36.2 megajoules/litre	$.156 \times 10^6$ Btu/IG
NATURAL GAS	37.2 megajoules/m ³	1.00×10^6 Btu/MCF
PROPANE	50.3 megajoules/kg 26.6 megajoules/litre	$.02165 \times 10^6$ Btu/lb $.1145 \times 10^6$ Btu/IG
ELECTRICITY	3.6 megajoules/kWh	$.003413 \times 10^6$ Btu/kWh

Infiltration — Doors And Windows

Worksheet 18-1

Page 1 of 3

Company: _____ Date: _____

Location: _____ By: _____

DESIGN REQUIREMENTS:

Temperature inside _____ °C (1)

Temperature outside _____ °C (2)

(1) - (2) = ____ - ____ = _____ °C (3)

Degree Days below 18.0°C _____ (4)
(Obtain from N.B.C.)

FUEL COSTS:

(Obtain from utility bills)

Gas ----- (Cf)(\$/m³) _____ (5)

Oil ----- (Cf) (\$/L) _____ (6)

Electricity ----- (Ce) (\$/kWh) _____ (7)

(Ignore demand charges)

EXISTING DOORS AND WINDOWS:

(Summarize sizes, types, condition, lengths and sizes of cracks, and frequency of opening.)

Existing Windows -

Existing Doors -

Type 1:

Type 1:

Type 2:

Type 2:

Type 3:

Type 3:

Infiltration — Doors And Windows

Worksheet 18-1

Page 2 of 3

Company: _____ Date: _____

Location: _____ By: _____

EXISTING INFILTRATION BY "CRACK" METHOD (See Table 3)

	Length (m)		Infiltration Rate [L/S(s·m)]		Total Infiltration (L/s)
Doors: Type #1	_____	x	_____	=	_____
#2	_____	x	_____	=	_____
#3	_____	x	_____	=	_____
Windows: Type #1	_____	x	_____	=	_____
#2	_____	x	_____	=	_____
#3	_____	x	_____	=	_____
Existing Infiltration =					_____ (8)

PROPOSED IMPROVEMENTS:

REVISED INFILTRATION BY "CRACK" METHOD:

	Length (m)		Infiltration Rate [L/S(s·m)]		Total Infiltration (L/s)
Doors: Type #1	_____	x	_____	=	_____
#2	_____	x	_____	=	_____
#3	_____	x	_____	=	_____
Windows: Type #1	_____	x	_____	=	_____
#2	_____	x	_____	=	_____
#3	_____	x	_____	=	_____
Revised Infiltration =					_____ (9)

Infiltration — Doors And Windows

Worksheet 18-1

Page 3 of 3

Company: _____ Date: _____

Location: _____ By: _____

INFILTRATION REDUCTION (fa):

fa = existing infiltration — revised infiltration

$$= \text{_____} (8) - \text{_____} (9) = \text{_____} (L/s) (10)$$

Total Infiltration (Heat Loss) Reduction:

$$Q = 1.232 \times fa \times (T_2 - T_1)$$

$$= 1.232 \times \text{_____} (10) \times \text{_____} (3) = \text{_____} (W) (11)$$

$$\text{i.e.} = \frac{\text{_____} (11)}{1000} = \text{_____} \text{ kW} (12)$$

ESTIMATED ENERGY COST SAVINGS PER ANNUM:

GAS:

$$= 2.95 \times \text{_____} (5) \times \text{_____} (12) \times \frac{\text{_____} (4)}{\text{_____} (3)} = \$ \text{_____} (13)$$

OIL:

$$= 2.73 \times \text{_____} (6) \times \text{_____} (12) \times \frac{\text{_____} (4)}{\text{_____} (3)} = \$ \text{_____} (14)$$

ELECTRICITY:

$$= 16.8 \times \text{_____} (7) \times \text{_____} (12) \times \frac{\text{_____} (4)}{\text{_____} (3)} = \$ \text{_____} (15)$$

ESTIMATED COST OF IMPROVEMENT: \$ _____ (16)

TOTAL ESTIMATED SAVINGS PER ANNUM:

$$\text{_____} (13) + \text{_____} (14) + \text{_____} (15) = \$ \text{_____} (17)$$

$$\text{SIMPLE PAYBACK} = \frac{\text{_____} (16)}{\text{_____} (17)} = \text{_____} \text{ years}$$

Heat Transmission — Walls

Worksheet 18-2

Page 1 of 2

Company: _____ Date: _____

Location: _____ By: _____

DESIGN REQUIREMENTS:

Temperature inside _____ °C (1)

Temperature outside _____ °C (2)

(1) - (2) = _____ - _____ = _____ °C (3)

Degree Days below 18.0°C _____ (4)
(Obtain from N.B.C.)

FUEL COSTS:

(Obtain from utility bills)

Gas ----- (Cf) (\$/m³) _____ (5)

Oil ----- (Cf) (\$/L) _____ (6)

Electricity ----- (Ce) (\$/kWh) _____ (7)

(Ignore demand charges)

WALL CONSTRUCTION “EXISTING”

SKETCH OR DESCRIBE “EXISTING” CONDITIONS

RSI = _____

$U = \frac{1}{RSI} = \text{_____} (8)$

WALL CONSTRUCTION “PROPOSED”

SKETCH OR DESCRIBE “PROPOSED” CONDITIONS

RSI = _____

$U = \frac{1}{RSI} = \text{_____} (9)$

See Materials/Systems Section and Table 1 in Appendix B for RSI-value of various building materials.

Heat Transmission — Walls
Worksheet 18-2
Page 2 of 2

Company: _____ Date: _____

Location: _____ By: _____

Net Wall Area (wall area minus area of all doors and windows)

Length x Width = _____ x _____ = _____ m²

Windows (sash area) (-) _____ m²

Doors (frame area) (-) _____ m²

Net Wall Area = _____ m² (10)

Heat Loss (Existing) = _____ (8) x _____ (10) x _____ (3)
= _____ W (11)

Heat Loss (Proposed) = _____ (9) x _____ (10) x _____ (3)
= _____ W (12)

Heat Loss (Reduction) = _____ (11) - _____ (12) = _____ W (13)
= _____ (13) = _____ kW (14)
1000

ESTIMATED ENERGY COST SAVINGS PER ANNUM:

GAS:

= 2.95 x _____ (5) x _____ (14) x _____ (4) = \$ _____ (15)
_____ (3)

OIL:

= 2.73 x _____ (6) x _____ (14) x _____ (4) = \$ _____ (16)
_____ (3)

ELECTRICITY:

= 16.8 x _____ (7) x _____ (14) x _____ (4) = \$ _____ (17)
_____ (3)

ESTIMATED COST OF IMPROVEMENT: \$ _____ (18)

TOTAL ESTIMATED SAVINGS PER ANNUM:

_____ (15) + _____ (16) + _____ (17) = \$ _____ (19)

SIMPLE PAYBACK = _____ (18) = _____ years
_____ (19)

Heat Transmission — Roofs

Worksheet 18-3

Page 1 of 3

Company: _____ Date: _____

Location: _____ By: _____

DESIGN REQUIREMENTS:

Temperature inside _____ °C (1)

Temperature outside _____ °C (2)

(1) - (2) = _____ - _____ = _____ °C (3)

Degree Days below 18.0°C _____ (4)
(Obtain from N.B.C.)

FUEL COSTS:

(Obtain from utility bills)

Gas _____ (Cf) (\$/m³) _____ (5)

Oil _____ (Cf) (\$/L) _____ (6)

Electricity _____ (Ce) (\$/kWh) _____ (7)

(Ignore demand charges)

ROOF CONSTRUCTION "EXISTING" — TYPE A

SKETCH OR DESCRIBE "EXISTING" CONDITIONS
AREA _____ m² (9)

RSI = _____

$$U = \frac{1}{RSI} = \text{_____} (8A)$$

ROOF CONSTRUCTION "EXISTING" — TYPE B

SKETCH OR DESCRIBE "EXISTING" CONDITIONS
AREA _____ m² (10)

RSI = _____

$$U = \frac{1}{RSI} = \text{_____} (8B)$$

See Materials/Systems Section and Table 1 in Appendix B for RSI-value of various building materials.

Heat Transmission — Roofs

Worksheet 18-3

Page 2 of 3

Company: _____ Date: _____

Location: _____ By: _____

ROOF CONSTRUCTION
"REVISED" — TYPE A

SKETCH OR DESCRIBE PROPOSED CHANGES

RSI = _____

$$U = \frac{1}{RSI} = \text{_____} (11A)$$

ROOF CONSTRUCTION
"PROPOSED" — TYPE B

SKETCH OR DESCRIBE PROPOSED CHANGES

RSI = _____

$$U = \frac{1}{RSI} = \text{_____} (11B)$$

ENERGY SAVINGS — TYPE A

$$\begin{aligned} \text{Heat Loss (Existing)} &= \text{_____} (8A) \times \text{_____} (9) \times \text{_____} (3) \\ &= \text{_____} \text{ W (12)} \end{aligned}$$

$$\begin{aligned} \text{Heat Loss (Proposed)} &= \text{_____} (11A) \times \text{_____} (9) \times \text{_____} (3) \\ &= \text{_____} \text{ W (13)} \end{aligned}$$

$$\begin{aligned} \text{Heat Loss (Savings)} &= \text{_____} (12) - \text{_____} (13) = \text{_____} \text{ W (14)} \\ &= \frac{\text{_____} (14)}{1000} = \text{_____} \text{ kW (15)} \end{aligned}$$

ENERGY SAVINGS — TYPE B

$$\begin{aligned} \text{Heat Loss (Existing)} &= \text{_____} (8B) \times \text{_____} (10) \times \text{_____} (3) \\ &= \text{_____} \text{ W (11)} \end{aligned}$$

$$\begin{aligned} \text{Heat Loss (Proposed)} &= \text{_____} (11B) \times \text{_____} (10) \times \text{_____} (3) \\ &= \text{_____} \text{ W (17)} \end{aligned}$$

$$\begin{aligned} \text{Heat Loss (Savings)} &= \text{_____} (16) - \text{_____} (17) = \text{_____} \text{ W (18)} \\ &= \frac{\text{_____} (18)}{1000} = \text{_____} \text{ kW (19)} \end{aligned}$$

$$\text{ENERGY SAVINGS — TOTAL} = \text{_____} (15) + \text{_____} (19) = \text{_____} (20)$$

Heat Transmission — Roofs

Worksheet 18-3

Page 3 of 3

Company: _____ Date: _____

Location: _____ By: _____

ESTIMATED ENERGY COST SAVINGS PER ANNUM:

GAS:

$$= 2.95 \times \text{_____} (5) \times \text{_____} (20) \times \frac{\text{_____} (4)}{\text{_____} (3)} = \$ \text{_____} (21)$$

OIL:

$$= 2.73 \times \text{_____} (6) \times \text{_____} (20) \times \frac{\text{_____} (4)}{\text{_____} (3)} = \$ \text{_____} (22)$$

ELECTRICITY:

$$= 16.8 \times \text{_____} (7) \times \text{_____} (20) \times \frac{\text{_____} (4)}{\text{_____} (3)} = \$ \text{_____} (23)$$

ESTIMATED COST OF IMPROVEMENT: \$ _____ (24)

TOTAL ESTIMATED SAVINGS PER ANNUM:

$$\text{_____} (21) + \text{_____} (22) + \text{_____} (23) = \$ \text{_____} (25)$$

$$\text{SIMPLE PAYBACK} = \frac{\text{_____} (24)}{\text{_____} (25)} = \text{_____} \text{ years}$$

Infiltration — Large Openings

Worksheet 18-4

Page 1 of 3

Company: _____ Date: _____

Location: _____ By: _____

DESIGN REQUIREMENTS:

Temperature inside _____ °C (1)

Temperature outside _____ °C (2)

(1) - (2) = _____ - _____ = _____ °C (3)

Degree Days below 18.0°C _____ (4)
(Obtain from N.B.C.)

FUEL COSTS:

(Obtain from utility bills)

Gas ----- (Cf) (\$/m³) _____ (5)

Oil ----- (Cf) (\$/L) _____ (6)

Electricity ----- (Ce) (\$/kWh) _____ (7)

(Ignore demand charges)

EXISTING OPENING:

(Summarize details of size and frequency of opening.)

Area of opening _____ m² (8)

Time area is open/week _____ h (9)

EXISTING INFILTRATION:

$f_a = E_o \times A \times V \times 1000 \times OT$ (see Fundamentals)

= 0.4 x _____ (8) x 1.7 x 1000 x _____ (9) = _____ (10), or
168

= 4.05 x _____ (8) x _____ (9) = _____ (10)

Infiltration — Large Openings

Worksheet 18-4

Page 2 of 3

Company: _____ Date: _____

Location: _____ By: _____

PROPOSED IMPROVEMENTS:

Area of opening _____ m² (11)

Time area is open/week _____ h (12)

REVISED INFILTRATION:

$$fa = E_o \times A \times V \times 1000 \times OT \text{ (see Fundamentals)}$$

$$= 0.4 \times \text{_____ (11)} \times 1.7 \times 1000 \times \frac{\text{_____ (12)}}{168} = \text{_____ (13), or}$$

$$= 4.05 \times \text{_____ (11)} \times \text{_____ (12)} = \text{_____ (13)}$$

INFILTRATION REDUCTION (fa):

fa = existing infiltration — revised infiltration

$$= \text{_____ (10)} - \text{_____ (13)} = \text{_____ (L/s) (14)}$$

Total Infiltration (Heat Loss) Reduction:

$$Q = 1.232 \times fa \times (T_2 - T_1)$$

$$= 1.232 \times \text{_____ (14)} \times \text{_____ (3)} = \text{_____ (W) (15)}$$

$$\text{i.e.} = \frac{\text{_____ (15)}}{1000} = \text{_____ kW (16)}$$

Infiltration — Large Openings

Worksheet 18-4

Page 3 of 3

Company: _____ Date: _____

Location: _____ By: _____

ESTIMATED ENERGY COST SAVINGS PER ANNUM:

GAS:

$$= 2.95 \times \text{_____} (5) \times \text{_____} (16) \times \frac{\text{_____} (4)}{\text{_____} (3)} = \$ \text{_____} (17)$$

OIL:

$$= 2.73 \times \text{_____} (6) \times \text{_____} (16) \times \frac{\text{_____} (4)}{\text{_____} (3)} = \$ \text{_____} (18)$$

ELECTRICITY:

$$= 16.8 \times \text{_____} (7) \times \text{_____} (16) \times \frac{\text{_____} (4)}{\text{_____} (3)} = \$ \text{_____} (19)$$

ESTIMATED COST OF IMPROVEMENT: \$ _____ (20)

TOTAL ESTIMATED SAVINGS:

$$\text{_____} (17) + \text{_____} (18) + \text{_____} (19) = \$ \text{_____} (21)$$

$$\text{SIMPLE PAYBACK} = \frac{\text{_____} (20)}{\text{_____} (21)} = \text{_____} \text{ years}$$

Bibliography

ASHRAE — (American Society of Heating, Refrigerating and Air Conditioning Engineers, Inc.) *Fundamentals Handbook*, 1981.

Carrier — (Carrier Air-Conditioning Company) *System Design Manual*, Part 1: Load Estimating.

Egan, M. David — *Concepts in Thermal Comfort*, New, Jersey, Prentice-Hall, Inc., 1975.

Lata, J. K. — *Walls, Windows and Doors for the Canadian Climate*, Ottawa, National Research Council, 1973.

RAIC — (Royal Architectural Institute of Canada), *Energy Conservation: Design Resource Handbook*. Toronto, The Carswell Printing Company, 1979.