

ERRATA

VOL. I.

On the typical example of curve diagrams of coal washing tests on page 201, Vol. I, the symbol-legend is indicated as follows:—

LEGEND: SYMBOLS

- Curve showing the relative quantities of the several sizes.
- △ " " " " " " " densities.
- " " " percentage of ash in each of the several sizes.
- ⊙ " " " " " " " material floating at the several densities.

The above legend is incorrect; it should read thus:—

- Curve showing the relative quantities of the several sizes.
- " " " percentage of ash in each of the several sizes.
- ⊙ " " " " " " " material floating at the several densities.
- △ " " " " " " " ash in material floating at the several densities.

VOL. II.

In footnote ¹ on page 5, Vol. II, several decimal points have been misplaced. The correct formula is as follows:—

¹ Kent's classification (Mech. Engrs. Pocket Book, 1904, p. 624) of American coals is:—

	Carbon Ratio	Fixed Carbon	Volatile Hydrocarbons
Hard dry anthracite	100 to 12	100.00 to 92.31	0.0 to 7.69
Semi-anthracite	12 " 7	92.31 " 87.50	7.9 " 12.50
Semi-bituminous	7 " 3	87.50 " 75.00	12.50 " 25.00
Bituminous	3 " 0	75.00 " 0.00	25.00 " 100.00

The "Carbon Ratio" is the quotient $\frac{\text{Fixed Carbon}}{\text{Volatile Hydrocarbon}}$

CANADA
DEPARTMENT OF MINES
MINES BRANCH

HON. W. TEMPLEMAN, MINISTER, A. P. LOW, LL.D., DEPUTY MINISTER;
EUGENE HAANEL, PH.D., DIRECTOR.

AN
INVESTIGATION
OF THE
COALS OF CANADA
WITH REFERENCE TO THEIR ECONOMIC QUALITIES :
AS CONDUCTED AT MCGILL UNIVERSITY, MONTREAL,
UNDER THE AUTHORITY OF THE DOMINION
GOVERNMENT.

IN SIX VOLUMES

BY

J. B. PORTER, E.M., D.Sc.

AND

R. J. DURLEY, M.A.E.

ASSISTED BY

THÉOPHILE C. DENIS, B.Sc., EDGAR SPANFIELD, M.Sc.,
AND A STAFF OF SPECIAL ASSISTANTS.

VOL. II



OTTAWA
GOVERNMENT PRINTING BUREAU
1912

PRICE \$1.00

No. 83

THE
COALS OF CANADA:
AN ECONOMIC INVESTIGATION
VOL II

PART VII
BOILER TESTS

BY

R. J. DURLEY

PART VIII
GAS PRODUCER TESTS

BY

R. J. DURLEY

PART IX
WORK OF THE CHEMICAL LABORATORY

BY

EDGAR STANSFIELD

TABLE OF CONTENTS.

VOLUME II

PART VII.

	PAGE
BOILER TESTS, by R. J. Durley.....	3
Types of boilers, and their efficiency.....	3
Coal, and its suitability for steam generating purposes.....	5
Boiler furnaces and their adaptability for various coals.....	7
Boiler trials, and their use in testing coals.....	9
Equipment: brief description of plant and apparatus used for boiler trials.	15
Method of conducting tests and making measurements: log and calculations for one trial.....	18
Duties of staff, method of handling fuel and starting and stopping trials.	18
Measurement of water, Dryness of steam. Flue gas analysis.	19
Results of boiler trial No. 58.	21
Log of trial with observation sheets.	21
Summary of observations.....	23
Summary of results.	26
Details of calculations involved in the determination of the resultant figures given in the summaries of ob- servations and results.	27
Remarks on boiler trials and their results.	32
Value of coal.	32
Composition of coals.	32
Condition of coals when tested.....	33
General tabular statement of results of whole series of trials..	33
Relative merit of the coals.	34
Treatment and behaviour of coal in fire.	39
Remarks on coals as arranged geographically by coal fields.....	40
Sydney coal field, Cape Breton co., N.S.	40
Inverness coal field, Inverness co., N.S.	41
Pictou coal field, Pictou co., N.S.	42
Springhill coal field, Cumberland co., N.S.	43
Joggins-Chignecto coal field, Cumberland co., N.S.....	44
Grand Lake coal field, N.B.	44
Souris, Edmonton, and Belly River coal fields, Saskatchewan and Alberta.	45
Frank-Blairmore coal field, Alberta.	46
Crowsnest coal field, B.C.	47
Cascade coal field, Alberta.	48
Nicola Valley coal field, B.C.	49
Nanaimo-Comox, and Alert Bay coal fields, B.C.....	50

PART VIII.

GAS PRODUCER TESTS, by R. J. Durley.

Gas producers and their method of working.	55
Gas producers for non-bituminous fuels.	58
Gas producers for bituminous fuels.	61
Gas producer tests, and methods of testing coals in gas producers.	66
Equipment of experimental plant for gas producer tests of Canadian coals.	72
General arrangement of plant and accessories.	77
Methods of conducting tests, and making measurements: (with log and calculations for one trial).	79
Method of handling fuel, and starting and stopping trials	81
Temperatures, pressures, and other details of test.	82
Determination of rate of fuel consumption.	84
Detailed results of producer trial No. 32.	85
Log of trial, with observation sheets.	85
Summary of observations.	86
Summary of results.	89
Details of calculations involved in the determination of the resultant figures given in the summaries of observations and results.	95
Remarks on gas producer trials and their results: value of coals for gas producer work	102
Treatment and condition of coals when tested.	102
General results.	102
Producer efficiency, as illustrated by proportion of combustible in coal, in refuse, and in producer contents.	103
Relative merit of the coals.	107
Remarks on coals, as arranged geographically by coal fields.	107
Sydney coal field, Cape Breton, N.S.	107
Inverness and Pictou coal fields, N.S.	108
Springhill and Joggins coal fields, N.S., and Grand Lake coal field, N.B.	109
Souris coal field, Sask., Edmonton and Belly River coal fields, Alta.	110
Frank-Blairmore coal field, Alta.	112
Crownsnest coal field, B.C.	113
Cascade coal field, Alta.	115
Nicola Valley, and the Nanaimo coal fields, B.C.	117
Heat expenditure with various coals.	118

PART IX.

WORK OF THE CHEMICAL LABORATORY, by Edgar Stansfield

Introduction.	121
Collection and treatment of samples.	122
Coal samples.	122
Ash samples.	126
Coke samples.	126
Gas samples.	126
Numbering of samples.	127
Records and calculations.	129
Air drying coal.	130
Analytical methods and derived results.	131
General remarks.	131
Moisture.	133
Fixed carbon and volatile matter.	134
Ash.	136
Carbon and hydrogen.	136
Sulphur.	140
Nitrogen.	143
Oxygen.	145
Calorific value of solid fuels.	146
Calorific value of ash free coal.	155
Calorific value calculated from analysis of coal.	155
Fuel ratio.	156
Carbon-hydrogen ratio.	156
Gas analysis.	157
Gas analysis with Orsat-Muncke apparatus.	158
Gas analysis with Randall and Barnhart apparatus.	158
Gas analysis with Bone and Wheeler gas analysis apparatus.	161
Calorific value of gaseous fuels.	165
Calorific value calculated from analysis of gas.	168
Miscellaneous determinations.	173
Experiments on the fusibility of ashes.	174
Discussion of work.	176
List of coals tested.	181
Sydney coal field, N.S.	181
Inverness coal field, N.S.	181
Pictou coal field, N.S.	181
Springhill coal field, N.S.	182
Joggins-Chignecto coal field, N.S.	182
Grand Lake coal field, N.B.	182
Souris coal field, Sask.	182
Edmonton coal field, Alta.	182

	PAGE
Belly River coal field, Alta.	182
Frank-Blairmore coal field, Alta.	183
Crowsnest coal field, B.C.	183
Cascade coal field, Alta.	183
Similkameen coal field, B.C.	183
Nicola Valley coal field, B.C.	184
Nanaimo-Comox coal field, B.C.	184
Alert Bay coal field, B.C.	184
Whitehorse coal field, Yukon Territory.	184
Summary record in tabular form of all chemical analyses, arranged by coal fields in geographical order.	Following 184

LIST OF TABLES

		PAGE
PART VII		
Table	I.	Detailed record of coal fired. 22
"	II.	Trials of No. 2 Babcock and Wilcox boiler with No. 36 coal Following 22
"	III.	Detailed record of gas analysis. 23
"	IV.	Summary record of boiler tests Following 32
"	V.	Trials of Georges Creek coal on No. 2 Babcock and Wilcox boiler 36
"	VI.	Coals in order of evaporation. 38
"	VII.	Remarks on combustion of Sydney coals. 40
"	VIII.	Evaporation with Sydney coals. 41
"	IX.	" " Inverness coals. 41
"	X.	Remarks on combustion of Pictou County coals. . . 42
"	XI.	Evaporation with Pictou County coals. 43
"	XII.	" " Springhill coals. 43
"	XIII.	" " Joggins-Chignecto coals. 44
"	XIV.	" " Grand Lake coal. 44
"	XV.	Remarks on combustion of lignites and lignitic coals 45
"	XVI.	Evaporation with lignites and lignitic coals. 45
"	XVII.	Remarks on combustion of Frank-Blairmore coals. 46
"	XVIII.	Evaporation with Frank-Blairmore coals. 47
"	XIX.	Remarks on combustion of Crowsnest coals. 47
"	XX.	Evaporation with Crowsnest coals. 48
"	XXI.	Remarks on combustion of Cascade coals. 49
"	XXII.	Evaporation with Cascade coals. 49
"	XXIII.	Evaporation with Nicola Valley coals. 50
"	XXIV.	Remarks on combustion of Vancouver Island coals. 50
"	XXV.	Evaporation with Vancouver Island coals. 51

	PAGE
PART VIII	
Table XXVI.	Composition of gases per cent by volume. 57
“ XXVII.	“ anthracite and coke. 57
“ XXVIII.	“ typical gases from bituminous coal 61
“ XXIX.	Observations of composition of gas by volume. . . 91
“ XXX.	“ “ gas meter and B.H.P. 92
“ XXXI.	“ “ gas calorimeter and coal weighed 93
“ XXXII.	“ “ temperatures and pressures. . . . 94
“ XXXIII.	Summary record of gas producer tests. Following 102
“ XXXIV.	Proportion of combustible in coal, in refuse, and in producer contents. 105
“ XXXV.	Performance with Cape Breton coals. 108
“ XXXVI.	“ “ Inverness and Pictou coals. . . . 109
“ XXXVII.	“ “ Springhill, Joggins, and Grand Lake coals. 110
“ XXXVIII.	Performance with lignites and lignitic coals. 111
“ XXXIX.	“ “ Frank-Blairmore coals. 113
“ XL.	“ “ Crowsnest coals. 114
“ XLI.	“ “ Cascade coals. 116
“ XLII.	“ “ Nicola Valley and Nanaimo coal. 117
“ XLIII.	Heat value of coal charged per B.H.P. per hour. . . 118
PART IX	
Table XLIV.	Report of analysis of coal—Coal Testing Labora- tory. 129
“ XLV.	Recorded temperature of water in calorimeter vessel. 148
“ XLVI.	Analysis of producer gas with Randall and Barn- hart apparatus. 161
“ XLVII.	Analysis of producer gas with Bone and Wheeler apparatus. 165
“ XLVIII.	Ethylene: gross or higher calorific value in B.T.U. per cub. ft., moist, at 60°F. and 30" 169
“	Ethylene: net or lower calorific value in B.T.U. per cub. ft., moist, at 60°F. and 30" 169
“ XLIX.	Carbon monoxide: gross and net calorific value in B.T.U. per cub. ft., moist, at 60°F. and 30" 169
“ L.	Methane: gross or higher calorific value in B.T.U. per cub. ft., moist, at 60°F. and 30" 170
	Methane: net or lower calorific value in B.T.U. per cub. ft., moist, at 60° F. and 30". 171
“ LI.	Hydrogen: gross or higher calorific value in B.T.U. per cub. ft., moist, at 60° F. and 30". 171
	Hydrogen: net or lower calorific value in B.T.U. per cub. ft., moist, at 60° F. and 30" 172
“ LII.	Comparative ash determinations. 179

		PAGE
Table	LIII. Summary of approximate errors in coal analyses..	180
"	LIV. Summary record of analyses of coals: Sydney coal-field, Cape Breton co., N.S. Following	184
"	LV. Summary record of analyses of coals: Inverness coal field, Inverness co., N.S. " "	184
"	LVI. Summary record of analyses of coals: Pictou coal field, Pictou, co., N.S. " "	184
"	LVII. Summary record of analyses of coals: Springhill coal field, Cumberland co., N.S. " "	184
"	LVIII. Summary record of analyses of coals: Joggins-Chignecto coal field, Cumberland co., N.S. " "	184
"	LIX. Summary record of analyses of coals: Grand Lake coal field, N.B. " "	184
"	LX. Summary record of analyses of coals: Souris coal field, Sask. " "	184
"	LXI. Summary record of analyses of coals: Edmonton coal field, Alta. " "	184
"	LXII. Summary record of analyses of coals: Belly River coal field, Alta. " "	184
"	LXIII. Summary record of analyses of coals: Frank-Blairmore coal field, Alta. " "	184
"	LXIV. Summary record of analyses of coals: Crownsnest coal field, Alta. " "	184
"	LXV. Summary record of analyses of coals: Cascade coal field, Alta. " "	184
"	LXVI. Summary record of analyses of coals: Similkameen coal field, B.C. " "	184
"	LXVII. Summary record of analyses of coals: Nicola Valley coal field, B.C. " "	184
"	LXVIII. Summary record of analyses of coals: Nanaimo-Comox coal field, Vancouver island, B.C. " "	184
"	LXIX. Summary record of analyses of coals: Alert Bay coal field, Vancouver island, B.C. " "	184
"	LXX. Summary record of analyses of coals: Whitehorse coal field, Yukon Territory. " "	184
"	LXXI. Summary record of analyses of coals: Standard coal used for comparison. " "	184

ILLUSTRATIONS

Photographs

PART VII		PAGE
Plate	XLVI. Boiler room, experimental steam plant, Department of Mechanical Engineering, McGill University.	16
PART VIII		
Plate	XLVII. Diagram of Westinghouse double zone producer, vertical section.	64
"	XLVIII. Down-draft producer (No. 4), Department of Mechanical Engineering, McGill University.	76
"	XLIX. Boys' gas calorimeter as set up for producer tests, Department of Mechanical Engineering, McGill University.	78
"	L. Interior of gas producer laboratory, looking west, Department of Mechanical Engineering, McGill University.	80
"	LI. Interior of gas producer laboratory, looking east, Department of Mechanical Engineering, McGill University.	80
PART IX		
Plate	LII. Small ball mill for grinding samples, Department of Mining and Ore Dressing, McGill University.	124
"	LIII. Small ball mill, opened for cleansing, Department of Mining and Ore Dressing, McGill University.	124
"	LIV. Drying apparatus—Chemical Laboratory, Department of Mining and Ore Dressing, McGill University.	132
"	LV. Kjeldahl nitrogen distillation apparatus, Chemical Laboratory, Department of Mining and Ore Dressing, McGill University.	144
"	LVI. Koehler bomb calorimeter, general view, Department of Mining and Ore Dressing, McGill University.	148
"	LVII. Randall and Barnhart gas analysing apparatus, general view, Department of Mining and Ore Dressing, McGill University.	158
"	LVIII. Bone and Wheeler gas analysing apparatus, general view, Department of Mining and Ore Dressing, McGill University.	162
"	LIX. Bone and Wheeler gas analysing apparatus, details, Department of Mining and Ore Dressing, McGill University.	162
"	LX. Rack for holding and storing gas samples.	164
"	LXI. Ash cylinders after heating, viewed at an inclination	176
"	LXII. Ash cylinders after heating, viewed from above.	176

Drawings

	PAGE
PART VII	
Fig. 32. Standard types of steam boilers	3
“ 33. Babcock and Wilcox boilers, Department of Mechanical Engineering, McGill University.	15
“ 34. General arrangement of experimental boiler plant, Department of Mechanical Engineering, McGill University	17
“ 35. Diagram showing boiler efficiency and rate of combustion	33
“ 36. Diagram showing boiler efficiency and percentage of fixed carbon.	34
“ 37. Diagram showing boiler efficiency and equivalent evaporation.	35
PART VIII	
Fig. 38. Diagram of simple form of gas producer	55
“ 39. Suction gas producer (Ruston and Proctor)	58
“ 40. Suction gas producer (Pintsch)	59
“ 41. Gas producer for lignite briquettes (Koerting)	63
“ 42. Twin down-draft gas producers (Power and Mining Machinery Co.).	64
“ 43. Double zone gas producer (Westinghouse)	66
“ 44. Suction producer No. 1, Department of Mechanical Engineering, McGill University.	75
“ 45. Down-draft producer (No. 4), Department of Mechanical Engineering, McGill University.	76
“ 46. Forty horse-power gas engine, Department of Mechanical Engineering, McGill University.	77
“ 47. Section through gas washer, Department of Mechanical Engineering, McGill University.	77
“ 48. General arrangement of experimental producer gas plant, Department of Mechanical Engineering, McGill University.	78
“ 49. Diagram showing producer efficiency and coal consumption per B.H.P. per hour.	107
PART IX	
Fig. 50. Stansfield pressure regulators, Models (a) and (b)	132
“ 51. Vertical section, Koehler calorimeter bomb	146
Fig. 52. Vertical section, Koehler calorimeter	147
“ 53. Section of glass parts of Randall and Barnhart gas analysing apparatus.	157
“ 54. Diagram of Bone and Wheeler gas analysing apparatus .	161
“ 55. Vertical section of Boys' gas calorimeter	165
“ 56. General view of Boys' gas calorimeter	167

Index.

List of Mines Branch Publications.

APPENDICES

VOL. III.—

APPENDIX I

COAL WASHING TESTS, by J. B. Porter.

VOL. IV.—

APPENDIX II

BOILER TESTS AND DIAGRAMS, by R. J. Durley.

VOL. V.—

APPENDIX III

PRODUCER TESTS AND DIAGRAMS, by R. J. Durley.

VOL. VI.—

APPENDIX IV

COKING TESTS, by Edgar Stansfield and J. B. Porter.

APPENDIX V

CHEMICAL TESTS, by Edgar Stansfield.

THE
COALS OF CANADA:
AN ECONOMIC INVESTIGATION
VOL. II

PART VII
BOILER TESTS
BY
R. J. DURLEY

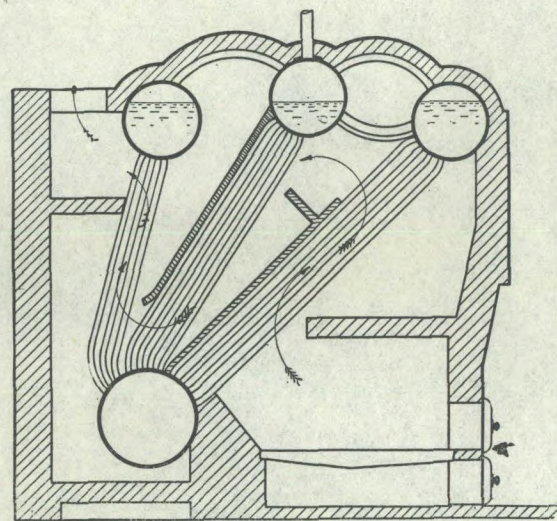

(a). Stirling water tube boiler.

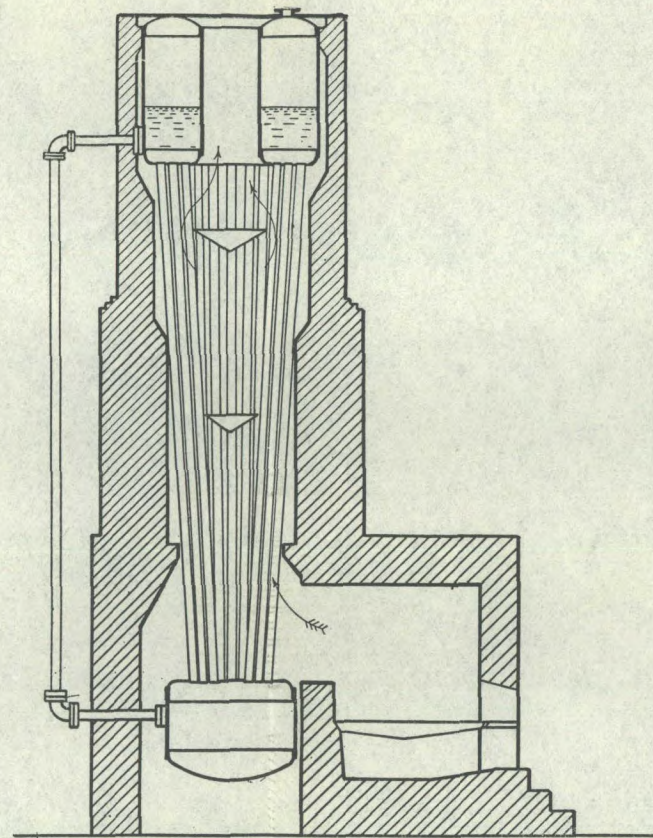

(b). Cahall water tube boiler.

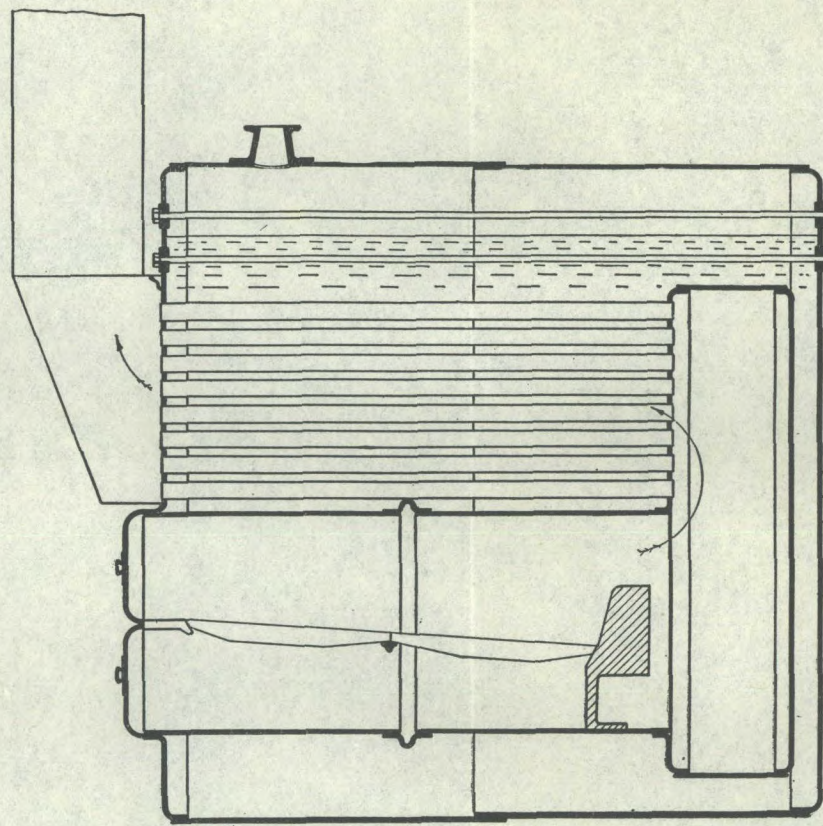

(c). Scotch, or marine boiler.

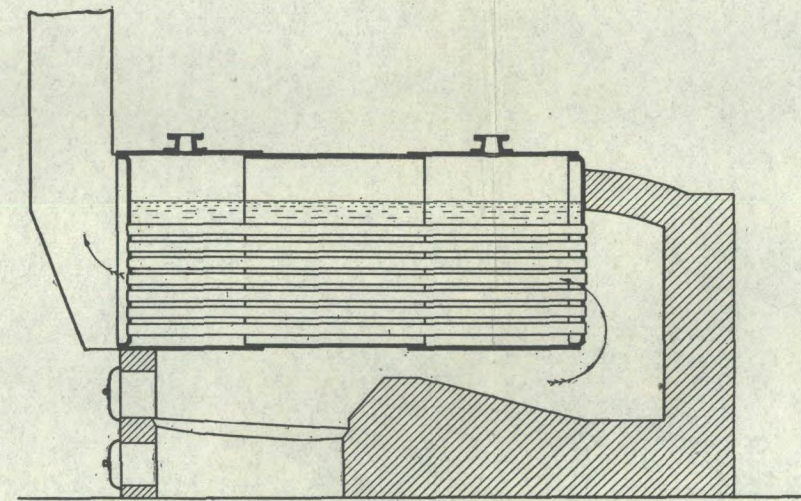

(d). Horizontal return tubular boiler.

FIG 32.—STANDARD TYPES OF STEAM BOILERS.

THE
COALS OF CANADA :
AN ECONOMIC INVESTIGATION

VOL. II

PART VII
BOILER TESTS

R. J. DURLEY

TYPES OF BOILERS AND THEIR EFFICIENCY

The following brief discussion of certain points connected with boiler practice will possibly be of service to readers who are interested in the quality of Canadian coals but are unfamiliar with steam engineering.

A typical boiler equipment designed for steam raising purposes includes: (a) the boiler proper, a vessel containing water and steam, capable of withstanding the assigned working pressure, and provided with sufficient external or internal heating surface for the transmission of the heat necessary to convert the water into steam at the desired rate; and (b) a furnace, either external or inside the boiler, designed for the combustion of a sufficient amount of the fuel to be used. It is customary to distinguish between water tube and fire tube boilers. In nearly all boilers a large proportion of the effective heating surface is composed of tubes, and these tubes may either be water tubes with water inside and the hot gases arising from the furnace outside, or fire tubes in which the hot gases pass through the tubes, whose outer surface is cooled by the water in the boiler. Fig. 32 shows in diagrammatic form the arrangement of two types of fire tube boiler, together with two well known forms of water tube boiler. It will be noted that the Scotch boiler is internally fired, while the others have external furnaces.

It is, of course, possible to have a well designed boiler, in which the heat developed by the furnace is thoroughly utilized, combined with a furnace of such defective construction that the combustion of the fuel is imperfectly or wastefully carried out. Or, the reverse may be the case; the furnace may be efficient while the boiler is wasteful, and a really economical steam generating plant evidently involves good efficiency of both boiler and furnace.

The *efficiency of a boiler* (including furnace) is generally expressed as a ratio which gives a numerical idea of the economy of the performance of the boiler and is the proportion of the total heat of the fuel which is utilized in the boiler by being employed in heating and evaporating water. The efficiency thus stated evidently takes account of all losses of heat occurring not only in the boiler but also in the furnace. In practice, from 50 to 75 per cent is a fair range of value for this efficiency. In other words, if supplied with

coal having a calorific value of 13,000 heat units per pound, a boiler and furnace of ordinary type will utilize from 6,500 to 10,000 heat units for the purpose for which the boiler is designed, the balance of the heat value of the coal being lost or wasted in various ways.

It has been noted that it is possible to have a very economical boiler combined with an uneconomical furnace. The *efficiency of the furnace* taken by itself would be measured by that proportion of the heat value of the fuel which is available for use in the boiler, and this available heat is evidently the calorific value of the fuel minus any heat losses due to incomplete and defective combustion, such losses being chargeable to the furnace proper rather than to the boiler.

The *efficiency of the boiler* alone is evidently that proportion of the heat actually rendered available by the furnace, which is utilized in the boiler and used for raising steam. This efficiency is based on the calorific value of the combustible actually consumed and takes account only of those losses which are chargeable to the boiler itself. The efficiency usually measured in a boiler test is connected with the efficiencies just mentioned by the relation

$$\text{Total efficiency} = \text{efficiency of boiler} \times \text{efficiency of furnace.}$$

In well operated boiler installations of good ordinary design and moderate size, the following table may be taken as giving roughly the distribution of the available heat expressed as percentages of the calorific value of the coal used as fuel.

	Per cent
Heating and evaporating water.	60 to 75
Heat lost in flue gases entering stack.	20 to 10
Heat lost by radiation from boiler.	10 to 4
Heat not developed due to imperfect combustion	5 to 1
Heat used in evaporating moisture in coal and unaccounted for.	5 to 10

The proportion of heat actually used in warming and evaporating water is usually greater in large boilers than in small, and is generally less the harder the boiler is worked, *i.e.*, the more steam is generated per square foot of heating surface per hour. All the best modern types of boiler seem to have about the same maximum efficiency, if well proportioned and worked under suitable conditions. Different types of boiler do, however, vary considerably as regards first cost, safety, freedom from trouble in operation, ease in cleaning, economy in maintenance, and suitability for use with a given kind of fuel. By the adoption of special heat saving appliances, together with careful design and construction, boiler-and-furnace efficiencies as high as 80 per cent have been reached in well conducted tests; but this is very unusual in practice.

COAL, AND ITS SUITABILITY FOR STEAM GENERATING PURPOSES

The customary classification of coals as anthracite, semi-anthracite, semi-bituminous, and bituminous¹ affords no idea as to the suitability of a coal for steam raising purposes, for coals of all these classes are satisfactorily used for steam boilers; nor can the chemical analysis of a coal be regarded as sufficient to enable us to decide on its steaming qualities. These can only be determined by the practical test of burning the coal in a standard type of boiler-furnace, of known efficiency when worked with some standard coal, and thus measuring the evaporative power.

Neglecting the cost of water, the cost of steam to the power user depends: (1) on the amount of heat utilized in the boiler, not from each pound but from each dollar's worth of coal as delivered to the boiler room; (2) on the cost of handling the coal in the boiler room, and (3) on the expense of dealing with the ashes produced. All these items are affected by various physical qualities of the coal and its ash, as well as by its chemical composition. The following notes will give an idea of some of the quantities used in boiler trial calculations and of the factors which influence the steaming quality of coal.

Calorific Value.—The *unit of heat* employed throughout this section of the report is that commonly employed by engineers, the British Thermal Unit (B.T.U.),² which is defined as the amount of heat necessary to raise the temperature of one pound of water through one degree Fahrenheit.³ Expressed in this manner, the *calorific value* of a coal is measured by the number of B. T. U. that would be generated by the complete combustion of one pound of the coal, and is a number ranging from about 7,500 B. T. U. for coals of poor quality to a maximum of about 15,000 B.T.U. for coals of high grade. Its value depends on the composition of the combustible portion of the coal as well as on the proportion of incombustible matter it contains. The proportion of the calorific value which can be utilized in the boiler will evidently depend on the efficiency of the boiler plant as well as on the nature of the coal and its treatment in the fire.

¹ Kent's classification (Mech. Engrs. Pocket Book, 1904, p. 624) of American coals is:—

	Carbon Ratio	Fixed Carbon		Volatile Hydrocarbons	
		%	%	%	%
Hard dry anthracite	100 to 12	100 to 92.31	0 to 7.69		
Semi-anthracite	12 " 7	92.31 " 87.5	7.69 " 12.5		
Semi-bituminous	7 " 3	87.5 " 0.75	12.5 " 0.25		
Bituminous	3 " 0	0.75 " 0	0.25 " 100		

The "Carbon Ratio" is the quotient $\frac{\text{Fixed carbon}}{\text{Volatile hydrocarbon}}$

Lignites, of course, belong to a separate class, and are essentially different from any of the above.

² In the chemical work connected with this report the gramme-calorie is taken as the heat unit. See Part IX.

³ The exact value of this quantity depends on the temperature of the water at which the measurement is made. The temperature of maximum density (or 39.1° F.) is commonly taken.

Theoretical Evaporative Power.—Since 966 B.T. U. are required to produce one pound of steam from water at a temperature of 212° F. and at atmospheric pressure (14.7 pounds per square inch)¹, and these conditions are taken as a standard in comparing figures as to steam production, the number of pounds of water which could be evaporated with an ideally perfect furnace and boiler from and at 212° F. will be found by dividing the calorific value by 966. This figure will evidently range from about 8 to about 15 pounds of water per pound of coal.

Chemical Composition.—The effects of the various constituents of a coal on its calorific value are discussed in a later portion of this report. Speaking generally, from the boiler user's point of view it may be said that coals containing a large amount of volatile hydrocarbons are more difficult to burn efficiently than those whose carbon is nearly all in the fixed form. This difference is due chiefly to imperfect combustion of the hydrocarbons, leading to the emission of unburnt gases and smoke.²

Coals high in sulphur are not so objectionable for steam raising as for metallurgical purposes, although iron sulphide in the form of pyrites occasionally leads to trouble due to clinkering and to destruction of fire bars.

Chlorine, probably present in coal as common salt, occurs in very small quantities and will give off a small amount of hydrochloric acid when the coal is burnt. It is possible that the corrosion of boiler tubes is partly due to this cause.

The ash or incombustible matter in coal is of very great importance to the boiler user, since as a rule ashes have to be carted away or otherwise dealt with at some considerable cost, and because a fusible ash forms clinkers which stick together in the fire, or adhere to the fire bars or to the brickwork of the furnace, and in many cases are troublesome when the fires are cleaned.

It is hardly necessary to point out that the frequency of cleaning fires has considerable effect on the economy of the plant. While cleaning is going on the fire doors are necessarily open, and the boiler is cooled by the rush of cold air; a good deal of combustible matter is thrown away in the debris removed from the fire,³ and the amount of heat wasted in the hot ashes is by no means negligible. The proportion of ash in coal is thus one of the most important indications of its quality. The ash in coal consists largely of clayey matter and is, therefore, high in silica and alumina. A coal whose ash is high in iron oxide is usually liable to give trouble from clinkering; but the formation of clinker also depends on the rate of combustion. With a high rate of combustion and a corresponding high furnace temperature, an infusible or difficultly fusible ash may melt and give trouble which would not arise at a more moderate rate of working. Some coals clinker so badly as to render it difficult to use them in certain types of mechanical stokers.

Moisture is always present in coal and diminishes its evaporative power. The moisture in freshly mined coal is gradually lost on exposure to the air,

¹ See pp. 12 and 13. (Equivalent evaporation from and at 212°).

² For recent information on smoke prevention, see Randall and Weeks, Bull. 373, U. S. Geol. Survey 1909.

³ See ash determinations in Summary Record of Trials.

until in the ordinary air-dried condition it retains from 2 to 6 per cent. Lignites and lignitic coals contain much larger quantities of moisture.

Other Physical Properties.—The value of a coal for steam purposes is affected by other qualities. A coal is said to cake when it softens, becomes pasty, and swells up on heating, so that the residual coke left when the gases have been drawn off shows little or no trace of the original pieces or particles of coal. Anthracite and certain other coals show nothing of this property, and coals may be found which exhibit every gradation from a non-caking coal to a coal which softens on heating so as to yield a single coherent mass. The methods of firing adopted with non-caking and with caking coals in a boiler furnace must be different. Non-caking coals should be fired evenly and lightly, and should be disturbed as little as possible after being placed on the fuel bed. A good fireman will direct each shovelful exactly where it is needed to close any hole which may be forming in his fire, and will avoid raking as far as possible, so as to diminish the loss of fuel dropping through the bars. With a caking coal this method of firing is not advisable, and it is a common practice to place such fuel at first just inside the fire door on a dead plate where it can undergo partial distillation, so that the resulting hydrocarbons can pass over the fire and be burned as completely as possible. The coal is afterwards pushed back over the fire bed and a fresh supply put on to coke. Caking coals are, therefore, difficult to fire efficiently, especially as their long flame makes it hard for the fireman to see holes in his fire. The cause of the property of caking in coals is not yet completely known.¹

The *mechanical strength and hardness* of coal affect its industrial value. The loss from breakage in transportation and handling in the boiler room is serious in many coals. It should be noted that very small sizes of coal and fine dust cannot be burned effectively on ordinary grates, and considerable economy can often be obtained by using screened sizes, utilizing the smalls by themselves by special methods of firing. Most mechanical stokers require coal of more or less uniform size, and uniformity in size is a great advantage in hand firing also.

BOILER FURNACES AND THEIR ADAPTABILITY FOR VARIOUS COALS

No one type of furnace can burn all kinds of coal with maximum efficiency. If the intensity of draft available is known, the grate surface required for the combustion of a given amount per hour of a given coal can be estimated from experimental data. The necessary amount of air for combustion passes much more easily through a bed of coal composed of large pieces than through one of the same thickness but made up of smaller particles. For example, with the finer sizes of anthracite coal it is impossible to obtain a high rate of combustion per square foot of grate unless a high air pressure is available, and the furnace must, therefore, be designed with a large grate surface. With coals which clinker badly a high rate of combustion per square foot is often

¹ See Part VI.

impossible on account of mechanical difficulties in handling the melted ash with a high furnace temperature. On the other hand, a high furnace temperature is desirable whenever possible, because it is then easier to arrange for thorough combustion of the inflammable gases arising from the fuel bed. It is found in ordinary practice with a draft of from 0.4" to 0.6" of water that good results are obtained when burning anthracites at from 12 to 15 pounds per square foot of grate per hour, and bituminous coals at from 15 to 20 pounds. Higher figures and better furnace efficiency can be obtained when conditions are favourable.

The furnace of an internally fired boiler is, as a rule, limited in size, and it is difficult to burn bituminous coal in such furnaces to the best advantage unless a suitable combustion chamber is provided in which the gaseous products of distillation can be burned before they are cooled by contact with the cold sheets and tubes of the boiler itself. For bituminous coal the best results are obtained where sufficient surface of hot brickwork is provided and a high temperature of the gases is thus maintained until combustion is complete. A horizontal tubular boiler should be set higher above the grate for bituminous than for anthracite coal for this reason. The furnaces of externally fired boilers in which large areas of brickwork are used have the disadvantage that air tends to leak through the walls (even if these are not cracked or defective) and this reduces the furnace efficiency and generally the boiler efficiency also.

Speaking generally, a furnace for burning anthracite coal should have a large grate surface and, if possible, should be so arranged that the heat radiated directly from the fuel may be taken up by a portion of the boiler heating surface. For bituminous coals higher rates of combustion are permissible, and the furnace should be so designed as to keep the gases hot until they are completely burned, this being the only way of preventing the formation of smoke. With such coals, also, it is desirable to have some means of admitting a regulated amount of air above the fire, either at the fire door or near the back of the fire, in order that it may mix with the combustible gases at a point where they can burn. Sufficient space above the fuel bed is desirable, especially for coals high in volatile matter. Attention should be given to the method of getting rid of ash and clinker. Rocking or shaking grates should only be used with coals which are not friable and do not break up when thrown on the fire, and with coals which do not yield a hard or sticky clinker. For caking coals, a proper dead plate should be provided, so that the fuel may be thoroughly coked before being pushed back. With certain clinking coals, the use of a steam jet under the grate renders the working of the fire less laborious; there is, however, reason to suppose that this use of steam only increases the efficiency of the process of combustion by the mechanical effect of the steam, by keeping the grate bars cool, and by making the removal of clinker less difficult. Where mechanical stokers are proposed, it is well to make certain before purchasing that the particular type of stoker selected will work well with the particular kind of coal available.

BOILER TRIALS AND THEIR USE IN TESTING COALS

Tests of two kinds are carried out on boilers, and have for their object either the determination of the steam raising qualities of the fuel employed, or the measurement of the efficiency of the particular type of boiler experimented on. In either case the experiment is conducted in the same way. The boiler-furnace is supplied with a known quantity of fuel, the amount of steam generated is measured, and, in complete tests, the amount of heat furnished by the coal and expended in evaporating the water is determined, together with the various losses of heat which occur. It has already been pointed out that the principal losses are those due to the high temperature of the gases passing to the stack, the heat lost by radiation from the boiler and accessories, and the loss due to imperfect combustion of the fuel, as evidenced by the presence of combustible matter in the ash and refuse withdrawn from the furnace, or sometimes in the flue gases.

The object of the boiler trials discussed in this report was, of course, to compare the behaviour and usefulness for steam raising purposes of the various samples of fuel supplied. In carrying out the trials two objects were, therefore, borne in mind: (1) to determine the amount of water evaporated per pound of coal under conditions as nearly uniform as possible in each case, and (2) to form an opinion as to the behaviour of the coal, the amount of labour required to work it in the fire, and its general suitability for steam purposes as evidenced by freedom from trouble arising from clinker, ash, and the like. For the purpose of obtaining information of this kind it is necessary to measure, weigh, or determine: (a) the amount of coal supplied to the boiler in a certain time, and (b) the amount of water turned into steam in the same time. The measurement of these quantities is not so simple as would appear at first sight, because the coal and water are not fed to the boiler at a uniform rate, and, further, it is not possible to work the boiler so that the amount of fuel on the fire at the end of the trial shall be exactly the same as the amount on the fire at the beginning of the trial. The amount of coal fired in a given time is not, therefore, an accurate measure of the amount of coal actually burnt. This cause of inaccuracy is a serious one, but can be overcome by making tests of such length that an error in estimating the condition of the fire at the beginning or end of the trial is negligible as compared with the total amount of coal fired. This is the method adopted in the tests here reported, and is described in the American Society of Mechanical Engineers Rules for conducting boiler tests¹ as the "alternate" method. Another way of dealing with the difficulty is to draw the fire just before the beginning of the test, commencing the test with a weighed quantity of fresh fuel, and drawing the fire again just before concluding the trial. The objection to this method of starting and stopping (known as the A.S.M.E. "standard" method) is that the boiler is inevitably cooled down by an unknown amount during the laborious processes

¹ See Trans. A.S.M.E., Vol. XXI, p. 42.

of drawing the fire and starting a fresh one. In any case the fire should be burned low both at the beginning and end of a trial, so as to diminish the possible difference in the amount of fuel on the grate at the commencement and finish of the trial. Evidently the fire at the end will be more charged with ash and clinker than at the beginning, a fact which also requires consideration. Another error arises if the steam is not dry as it leaves the boiler; in other words, the steam may carry over into the steam pipe a certain amount of mechanically entrained moisture. In this case the amount of water pumped into the boiler would not be an accurate measure of the amount of water turned into steam, inasmuch as all the water would not have been evaporated. A somewhat similar error is produced if there is a leak in the boiler, blow off pipe, feed pipe, or feed pump, in which case the whole of the water supplied to the feed pump does not reach the boiler or leaks out before being evaporated, and the boiler is, therefore, credited with evaporating water which has never been turned into steam. In a carefully made boiler trial proper precautions have to be taken against the introduction of errors from any of the above-mentioned causes, and this was, of course, done in all the trials under discussion.

In order to make a fair comparison of the evaporative powers of different coals, it is desirable not only to keep the running conditions as uniform as possible during the whole of the test of each coal, but also to arrange the tests so that every sample may have the same chance of developing its maximum evaporative effect. The problem thus becomes a very complicated one. The first condition is easy, but to fulfil the second it would be necessary to make a complete series of trials with each coal, at various rates of combustion, in the same boiler, and this series would then have to be repeated with boilers and especially furnaces of various designs until the most favourable working conditions for each coal were found. The expenditure of time, money, and coal required for this course would evidently be prohibitive in the case of a series of tests like the present.

In the series of tests here reported on, the amount of each sample of coal available was in many cases sufficient for only one ten hour test (and in no case sufficient for more than two tests) on a boiler rated at 60 H.P., and even under these conditions the question of the transportation, storage, and handling of nearly seventy separate lots of fuel became a sufficiently serious one.

After much consideration it was decided that since only one test could be assured with each coal, all the tests should be carried out at about the same rate of evaporation. The coals of poorer quality had, therefore, to be burnt at a rather higher rate of combustion per square foot of grate than the others, but it was felt that this condition represented closely that met with in practice, for it is rare to find that a steam user changes his boiler arrangement or grate area materially when changing from one coal to another, except when there is a very fundamental difference in the fuel (*e.g.*, when anthracite is to be burnt instead of bituminous coal). The rate of evaporation selected and intended in all the trials (about $3\frac{1}{4}$ pounds of water per square foot of heating

surface per hour) was that at which the test boiler was known to give approximately its best efficiency with a standard American coal (Georges Creek, Cumberland, Md.)

In this connexion it should be noted that the boiler in question has a somewhat lower efficiency¹ than could have been obtained had a larger unit been used. The evaporative results are, therefore, all lower than would be obtained with the same coals on tests with a larger and more efficient boiler, but are believed to represent fairly the results to be expected from small units not specially equipped for economical working. The comparative values would probably not have been appreciably changed if the coals had been tested on a larger scale.

It is also possible that higher efficiencies could have been obtained in these tests if it had been possible to make changes in the grate bars, furnace fittings, and brickwork with a view to suiting the peculiarities of each sample, but this course appears inadvisable unless there is enough of each coal to make at least three, or better, four, tests with each, so as to make sure that any changes are beneficial rather than the reverse. On the whole, therefore, it seemed better to retain the same furnace and furnace fittings throughout,² even at the risk of placing some samples at a slight disadvantage, so long as the equipment selected was of standard type and reasonably well suited to the majority of ordinary coals. In any case, differences of furnace efficiency due to slight unsuitability of grate bars, or the like, would be masked by any error in the method of working the fire.

The method of firing adopted in the case of any particular coal may have more effect on the result of a boiler test than any other circumstance. It is safe to say that no mechanical stoker yet devised has been able to equal the results obtained by first-class hand firing, and, on the other hand, a poor fireman can often waste more fuel than even a poorly operated mechanical stoker. Hence, it is of the greatest importance, in making comparative tests of coal, to have a good and experienced fireman who is quick to see and adopt the best method of firing for each coal, and his work must be checked by every possible means as the trial proceeds. Whenever possible, a preliminary run should be made, to determine the thickness of fire and intensity of draft which will give the minimum air consumption compatible with good combustion. For this purpose a CO₂ recorder can be made to render valuable service, but proper flue gas analysis by a competent chemist is, of course, preferable. If no preliminary run can be made, all that can be done is to work the fire as the experience of the fireman indicates, changing the conditions of air supply, thickness of fire, etc., at once if the method first adopted gives unsatisfactory results. If possible, the same fireman should make all the tests in the series.

¹ For description of the boiler and its characteristics, see p. 15. For results of tests made with standard coal, see p. 36.

² For three tests in which the coal was very small, an exception was made, and special grate bars with narrow air spaces were used. (See Trials 67, 69, and 70.)

The following were adopted as the main conditions governing the series of tests here reported, and are believed to outline the best course that could be taken under the circumstances:—

(1). In each test the rate of combustion was adjusted to give as nearly as possible the same amount of steam per hour, viz., about 1,800 pounds. The boiler efficiency throughout all the tests should, therefore, be approximately the same. The furnace efficiency, however, would tend to be somewhat different in different tests, since different coals would have different rates of combustion, and also on account of variation in the qualities of the coals.

(2). It was decided to use hand firing on fixed grate bars and to employ the same fireman throughout all of the tests. Fortunately this was possible.

(3). The duration of each of the trials was about ten hours. This is enough when burning 250 to 300 pounds of coal per hour to ensure that only a small error arises in the measurement of the fuel on account of the difference in the amount of coal on the grate at the beginning and at the end of the trial.

(4). In addition to the measurement of coal and water and other necessary observations, note was taken of any difficulties arising during the working of the fire, the amount and nature of clinker formed, and the amount of smoke produced, with a view to obtaining a general idea as to the behaviour of the coal in each case. It is hoped that information gathered under this head will be of considerable assistance in forming an opinion as to the value of any particular coal.

Brief notes are appended with reference to certain of the results and calculations of a boiler trial:—

Evaporation of Water.—In order to evaporate the water which is pumped into a boiler it is necessary to supply sufficient heat to warm this water from the feed temperature to the temperature at which the boiler is working. A further supply of heat must then be furnished in order to turn the heated water into steam, the sum of these two quantities of heat being taken as the heat given to each pound of water or as the actual heat of evaporation of each pound of steam.

Equivalent Evaporation.—As it is difficult to compare the results of tests in which the steam pressure and temperature and the feed water temperature are all different, it is necessary to reduce the results of such trials to a common basis. This is done by computing the evaporation from and at 212° F., a figure known as the *equivalent evaporation per pound of coal from and at 212°* being obtained. In order to turn one pound of water at 212° F. into steam of the same temperature about 966 B. T. U. are needed.

Thus, suppose that in a given trial it was found that the feed temperature and other conditions were such that 1,100 B. T. U. were used to turn each pound of feed water into steam, and that the actual amount of water evaporated per pound of coal was 7.4 pounds, the equivalent amount of water which would be evaporated per pound of coal from and at 212° F. (with the same expenditure of heat) would be $7.4 \times 1,100 \div 966$, that is, 7.4×1.138 , or

8.4. The equivalent evaporation worked out for each test thus affords a numerical basis for the comparison of the evaporative powers of all the coals.

Draft.—The draft in a boiler furnace is measured by the difference of air pressure under which the air necessary for combustion passes through the layer of fuel lying upon the grate. It is evident that the thicker the bed of fuel and the more closely the particles of coal composing it are packed, the greater will be the draft required. This draft is usually measured in inches of water and is indicated by the difference of water level in the two limbs of a U tube, one being open to the atmosphere, and the other connected to the place where the pressure or vacuum is to be measured. A pressure of 5.2 pounds per square foot is required to maintain a column of water 1" in height, and a draught of 1" of water, therefore, means that the air pressure below the grate is 5.2 pounds per square foot greater than the air pressure above the layer of fuel.

Boiler Horse-power.—The figure known as boiler horse-power is commonly used to express the evaporative capacity of the boiler, or its nominal rate of steam production. When expressed in this manner the evaporation of 30 pounds of water per hour from a feed temperature of 100° F. and at a gauge pressure of 70 pounds per square inch is equivalent to one boiler horse-power. The evaporation of $34\frac{1}{2}$ pounds of water per hour from and at 212° F. represents the same expenditure of heat and may be used to represent the same quantity. The horse-power of a boiler is, therefore, found most conveniently by dividing the equivalent evaporation per hour from and at 212° F. by $34\frac{1}{2}$.

Steam Dryness.—The amount of moisture in the steam furnished by a boiler in which the formation of steam is not too rapid will generally be less than 3 per cent, unless the feed water contains substances which cause foaming. In all complete boiler tests the moisture in the steam should be measured, for reasons which have already been pointed out, and this is most easily done by the use of a throttling calorimeter.

When steam containing moisture is allowed to escape through an orifice or valve in such a manner that its pressure is reduced, it is found that the steam is drier at the low pressure than was the case originally. Thus, for example, one pound of water at 32° F. requires about 1,150 B.T.U. to convert it into steam 96 per cent dry, or containing 4 per cent of moisture, at 100 pounds per square inch. A pound of such steam, therefore, may be considered as having 1,150 B.T.U. stored up in it. When allowed to blow through a small orifice, in such a way that no heat is lost by conduction or otherwise, into a space where there is a pressure of say 15 pounds per square inch, the moisture will be dried up or evaporated until the heat stored in each pound is the same as before. This will occur (with a lower pressure of 15 pounds per square inch) when the moisture in the steam has just been evaporated, as may be verified by calculating the total heat of one pound of dry steam at a pressure of 15 pounds per square inch. This will be found to amount also to 1,150 B.T.U.

In measuring the dryness of steam by means of the throttling calori-

meter, the wet steam is throttled until it is completely dry or even a little superheated. From observations of the temperature and pressure at which this condition occurs, the original state of the steam is calculated by the aid of steam tables.

Air Used for Combustion.—The combustion of coal in a boiler furnace should be carried on with only a slight excess of air supply over the amount just required for complete combustion. Thus, the flue gases from the furnace should show only a small amount of free oxygen, the bulk of the oxygen in the air used having combined with carbon or hydrogen from the fuel to form either carbon dioxide or steam. An excess of air carries away and wastes heat which might otherwise be utilized.

The direct measurement of the air entering a boiler furnace by means of an anemometer is difficult and unsatisfactory, and it is customary to control and measure the amount of air used by the results of chemical analyses of the flue gas.¹ Assuming that a satisfactory sample of the flue gas has been obtained and accurately analysed, the weight of carbon contained in 100 pounds of the gas can be calculated, and hence the amount of air used per pound of carbon burnt. The amount of carbon burnt per pound of coal fired being known, it is easy to work out the number of pounds of air drawn into the furnace per pound of coal fired. The heat lost or carried away to the stack by the hot flue gases can then be calculated if the flue gas temperature and that of the boiler room or air supply to the boiler are known. The amount of air which would just suffice to burn one pound of coal completely is usually from 10 to 12 pounds, depending on the composition of the coal. Good results are obtained with an ordinary boiler furnace when the air used is from 15 per cent to 25 per cent in excess of this, say 12 to 16 pounds of air per pound of coal. In such a furnace it is seldom possible to obtain good combustion with a smaller excess of air than the above. Some coals are very difficult to work without admitting a considerably greater excess of air.

Radiation Losses —Very little reliable information is available regarding the heat lost by radiation from steam boilers, as the quantity in question is very difficult to measure experimentally. The A.S.M.E. code of rules for boiler trials provides that radiation losses shall be included with the loss due to unconsumed hydrocarbons in the flue gas and other indeterminate losses. An attempt at measuring the radiation loss in an ordinary boiler may be made by partly bricking over the grate, and determining the amount of coal required to maintain a constant steam pressure (and presumably a constant temperature also) during a sufficiently long period of time. The average of seventeen trials made by Donkin and Kennedy on different boilers² in this manner gives about 5·8 per cent of the total heat of combustion. The radiation loss is, however, proportionately larger in small than in large boilers, and larger in boilers with brick settings than in boilers having less radiating surface. Radiation losses up to 10 per cent of the heat developed by the coal at the rated capacity of the boiler are probably not uncommon.

¹ For flue gas analysis methods adopted in these tests, see Part IX.

² "Engineering," 1897.

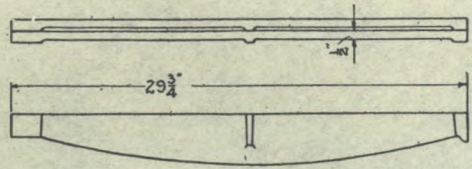

$\frac{1}{4}$ " air space was used for all trials except Nos 67, 69 & 70. Coal Nos 48, 51 & 52, in which cases an $\frac{1}{8}$ " air space was used.

— Detail of Fire Bars. —

- | | |
|---------------|-----------------------------------|
| Draft Gauges | — A Pressure above fire. — |
| | — B Pressure in ash-pan. — |
| | — C Flue pressure. — |
| Sampling Pipe | — D Flue gas analysis. — |
| | — E Thermometer, (flue gas). — |
| | — F Thermometer, (calorimeter). — |

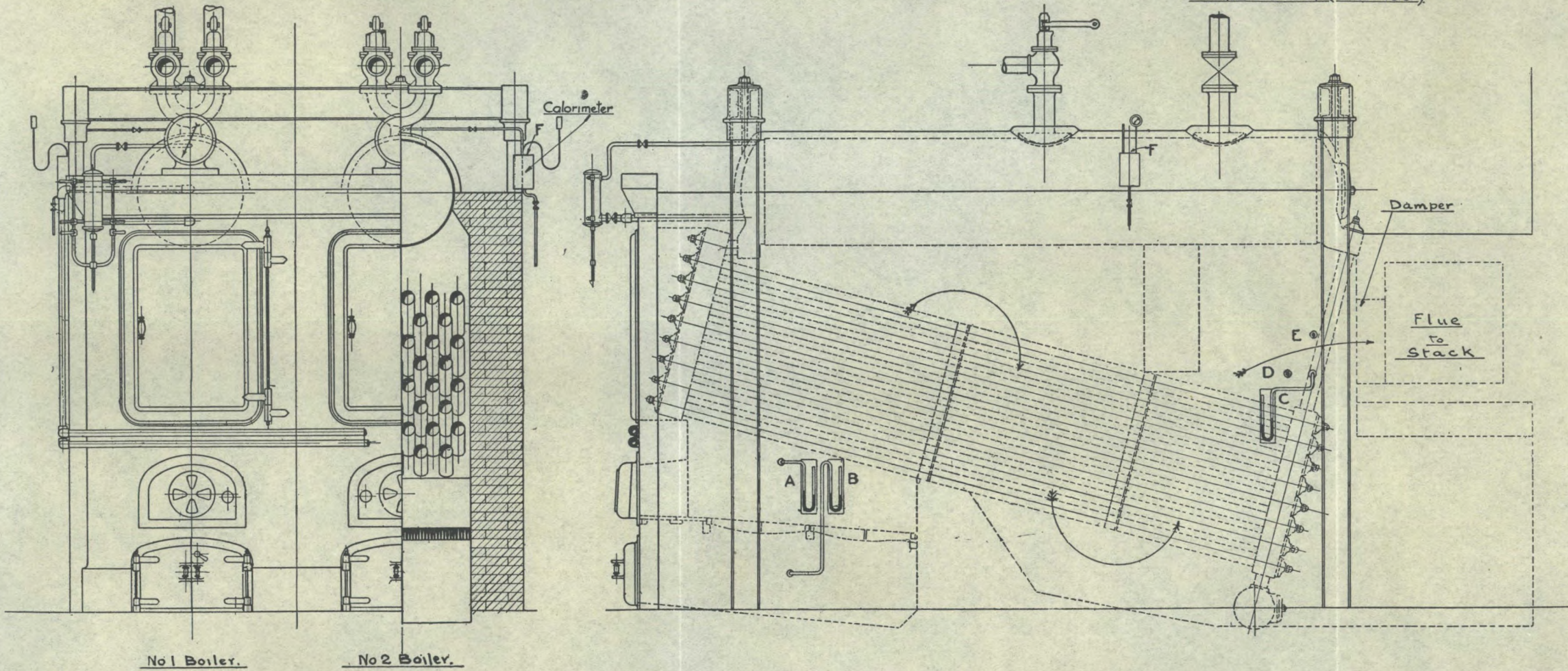

Fig. 33. Babcock and Wilcox boilers. Department of Mechanical Engineering, McGill University.

EQUIPMENT

BRIEF DESCRIPTION OF PLANT AND APPARATUS USED FOR BOILER TRIALS

The boiler on which the tests here reported were made was No. 2 of a pair forming part of the experimental equipment of the Department of Mechanical Engineering, McGill University. It is of the Babcock and Wilcox single drum type and the leading dimensions and particulars are as follows:—

Heating surface (tubes).....	sq. ft.	593
“ “ (drum etc).....	“	46
“ “ Total.....	“	639
Grate surface.....	“	16·79
Width of grate.....	feet	3·25
Length of grate.....	“	5·167
Height, grate to lowest tier of tubes.....	inches	{ at front 24 at back 15
Approximate width of air spaces.....	$\frac{1}{4}$ " (and $\frac{1}{8}$ " in special cases)	
Proportion air space to grate surface.....	30% (and 15% in special cases)	
Mean diameter of steam drum.....	inches	36 (inside)
Length of steam drum exposed.....	feet	12·37
Number of tubes.....		40
Diameter of tubes (external).....	inches	4
Length of tubes exposed.....	feet	13·66
Ash pit below grate surface.....	inches	{ at front 25 at back 22
Total water space.....	cub. ft.	110
Total steam space.....	“	31
Ratio heating surface to grate surface.....		38·1 : 1
Working pressure.....	lbs. per sq. in.	120

When the water stood at $4\frac{1}{2}$ " in the gauge glass the boiler contained 1,720 pounds of water, each inch in the gauge glass corresponding to a weight of 152 pounds of water.

The general arrangement of the boiler is shown in Fig. 33, and it was set in battery with another boiler of exactly the same make and construction, except that No. 1 boiler was originally fitted with a Jones stoker (not shown in the drawings), and No. 2, on which the experiments were made, was fitted with a plain cast iron grate. The furnace of No. 2 boiler, as will be seen from the drawings, is of the usual type, and the baffling is the standard Babcock and Wilcox arrangement consisting of firebrick tiles forming partitions placed transversely to the tubes with the smoke connexion to the flue in rear. The furnace walls are lined throughout with firebrick. Provision was made for blowing steam under the grate when necessary, and also for the use of water in the ash pit—with some of the coals tested the necessity of a steam supply under the grate was amply demonstrated. The steam used under the grate during the trials was not charged against the boiler, because the desired effect could have been obtained by other methods not involving additional expense in operation.

The furnace door was of cast iron, hinged, and provided with an adjustable grill or louvre opening for admission of air above the bars, and with a perforated internal baffle plate. There was no other arrangement for admitting air above the grate.

The brickwork of the furnace and boiler was thoroughly repaired shortly before the tests and was in good order throughout the trials.

Stack.—The boiler was connected by means of a brick flue to a stack about 100 feet high and 36" square inside. This stack also took flue gases from other boilers in the same boiler room, but as these boilers were not working hard during the trials, some being laid off and two only used for auxiliary purposes, and as anthracite coal was burnt in these, there was no difficulty in obtaining information as to the smokiness of the coals under test. The furnace was not equipped with any special form of smoke preventer as it was felt that observations on the smoke produced by the various coals would be of greater interest if the boiler were working under conditions usual in practice. The general arrangement of the boiler plant is shown in Fig. 34 and in Plate XLVI.

Draft.—Provision was made for forced draft by means of a fan driven by a 4" × 4" high speed engine. In this way any air pressure in the ash pit up to 1½" of water could be obtained, and this equipment was found very necessary in the case of certain coals. The steam used by the forced draft fan engine was not charged against the boiler, as a sufficient draft could have been obtained for any of the coals used had the stack been of sufficient capacity. The natural draft actually available was such as to give about 0.4" at the damper under favourable conditions. Draft gauges were fitted below the grate, above the fire, and at the damper. These draft gauges (shown at A, B, and C, Fig. 33) were of the ordinary U tube form, and the differences of pressure were read directly in inches of water. The damper was of the sliding type and adjusted by hand.

Steam Pipe Arrangement.—The steam pipes in the boiler room are arranged as a ring main, and are shown in Fig. 34; they were properly covered during the tests. A portion of the steam produced by the boiler during the tests was delivered to the electric generating station of the University. At times, however, of very light load on the power plant, the boiler under test furnished more steam than was required for the engines, in which case it was allowed to escape to the atmosphere through the safety valves.

Dryness of Steam.—The dryness of the steam produced was measured by a Peabody throttling calorimeter arranged as shown at F in Fig. 33. The results of a large number of careful trials which had been made on No. 2 boiler previous to the tests here reported, show that this boiler can be depended on to give commercially dry steam at rates of evaporation considerably greater than those used during the official tests. This fact was borne out by all the calorimeter determinations.

Boiler Feeding Appliances.—Two wrought iron rectangular weighing tanks, each 25" × 25" × 24", were used to receive water drawn from the city mains. Each was mounted on Fairbanks standard platform scales of 1,000 pounds capacity reading to one-half pound. The tanks had quick opening valves,

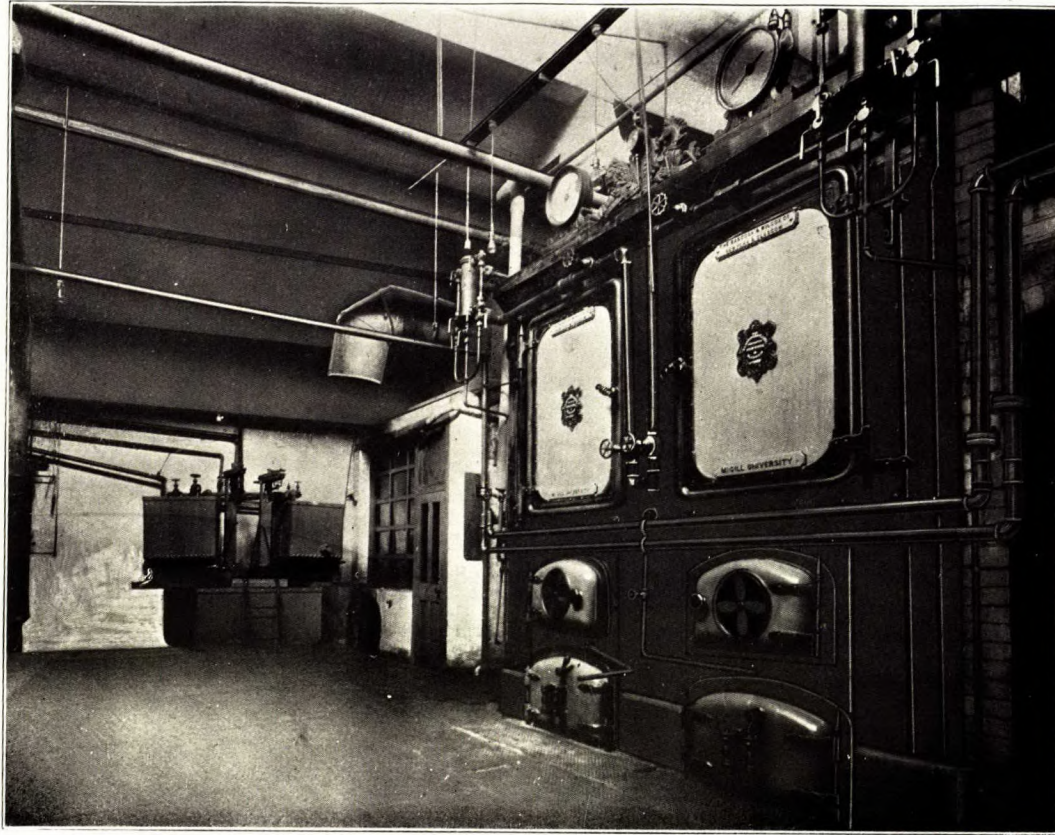

Boiler room. Experimental Steam Plant. Department of Mechanical Engineering. McGill University.

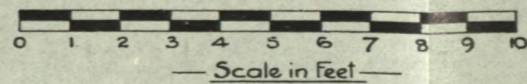
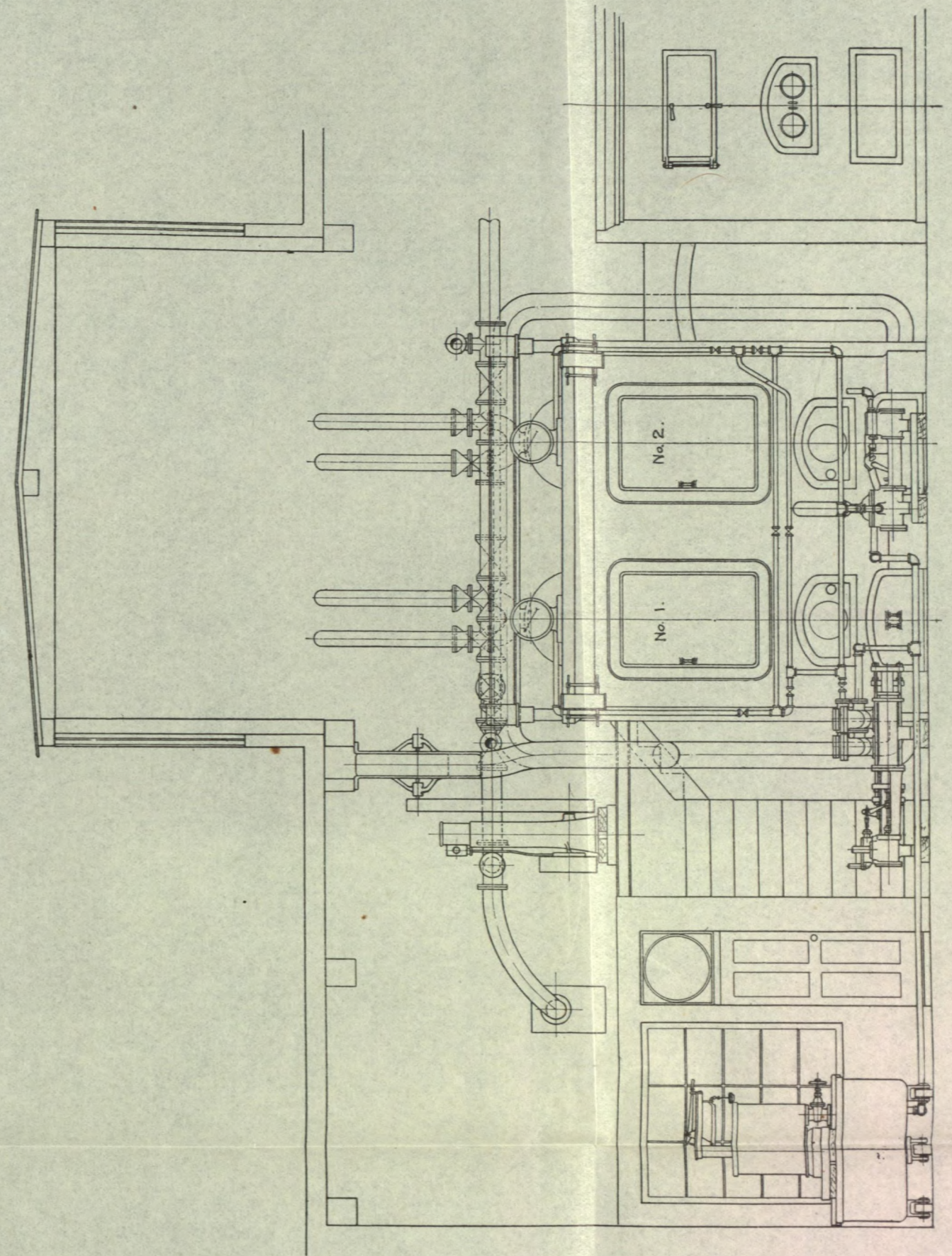
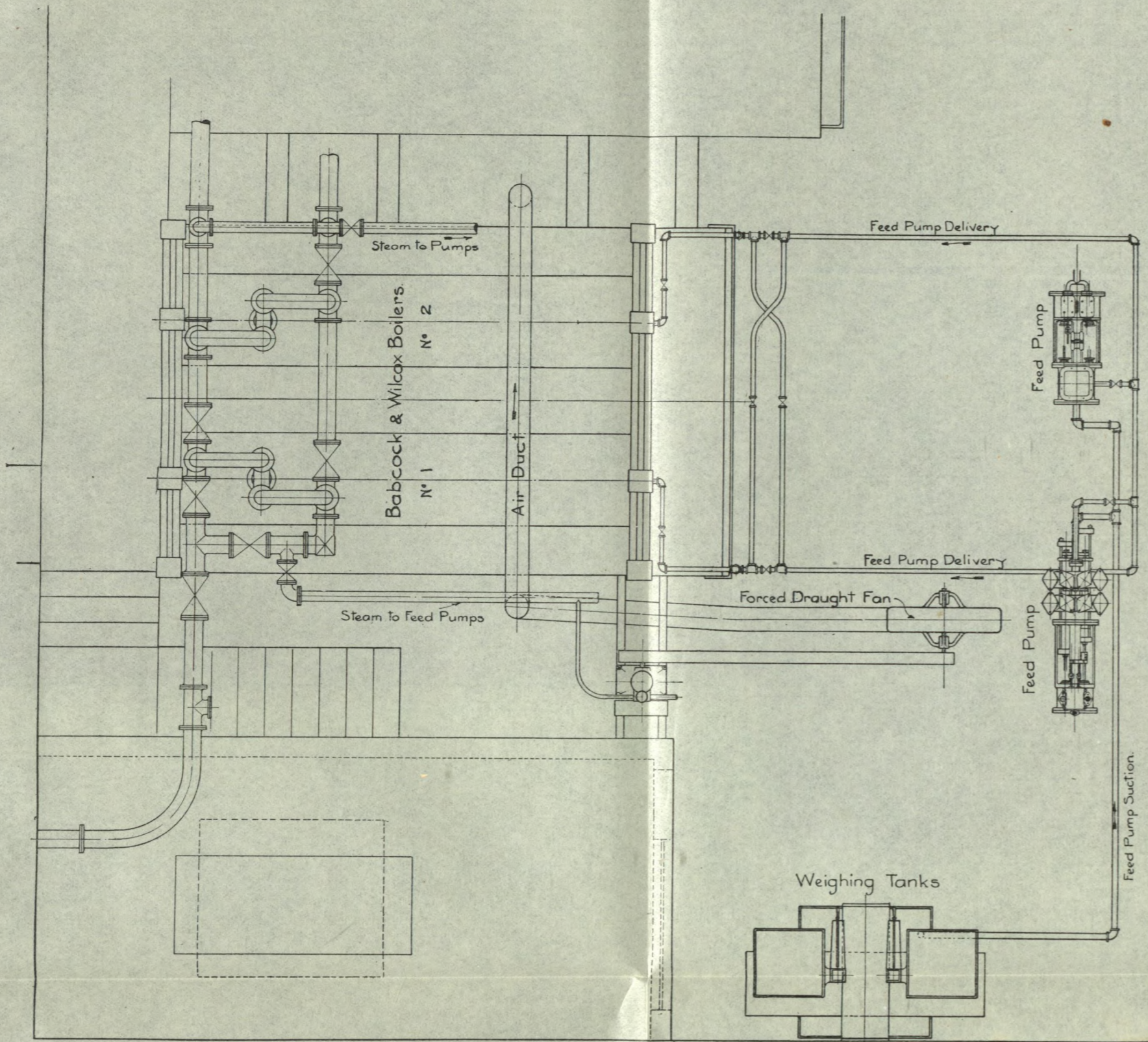

Fig. 34. General arrangement of experimental boiler plant. Department of Mechanical Engineering, McGill University

discharging into a larger tank below them from which the feed pumps drew. In this lower tank a wooden T gauge was provided to which the water level was adjusted at the beginning and end of the trial.

Two feed pumps were provided, each of the duplex steam driven type: one 6"×4"×6" and one 5¼"×3"×6". Their connexions were such that the pump not in use could be completely cut off by blank flanges. This arrangement was also carried out with the feed piping, all branches through which leakage could possibly occur being blank flanged during the tests.

The blow off piping of the boiler was arranged so that the open end was visible and was disconnected from the blow off line.

Coal Scales, etc.—Coal was weighed in a box, placed on a Fairbanks standard platform scale of 2,000 pounds capacity.

Sample Cans.—Sample cans provided with tight fitting covers were used for taking samples of the coal.

Flue Gas Sampling Apparatus.—The flue gas analysis was carried out on samples of flue gas, which were taken periodically from a stream continuously drawn from the boiler outlet by a water jet exhauster. The chemical apparatus and methods of analysis are fully described in Part IX of this report. The sampling tube, placed in the outlet from the boiler into the main flue and close to the damper (at **D** Fig. 33), consisted of a piece of 1¼" seamless steel tube closed at one end and perforated with a series of holes $\frac{5}{16}$ " in diameter and about 6" apart. This sampling tube extended across the opening from the boiler into the flue.

The standard sampling apparatus recommended by the American Society of Mechanical Engineers was not employed, because it would have been very difficult to install in the position available, and because as a result of a series of experiments made with a view to determining the effect of hot flue gases on iron, it was thought advisable to try an enamelled surface for the collecting tube. This material was found to give results which agreed well with those obtained from water-cooled collecting tubes, and the difficulties arising from scale, etc., in the water cooled tubes, were in this way avoided. It was, therefore, finally decided to use a steel tube, enamelled inside and out and arranged as described above. This was found to give very satisfactory and consistent results, the enamelling being done, of course, after the $\frac{5}{16}$ " holes were drilled, and in such a way that no metallic iron was exposed to the action of the hot flue gas.

As a general check on the flue gas analysis, a Simmance-Abady CO₂ recorder was installed in the boiler room, and its indications, while not in exact numerical agreement with the results of the gas analysis as far as percentage of CO₂ was concerned, served to show whether the chemical results on a comparatively small number of samples really gave representative figures. Considerable trouble was experienced in the operation of the CO₂ recorder, and in certain of the trials its use had to be discontinued. The difficulties encountered arose chiefly from dust in the flue gas sampled, owing to ineffective filtration in the apparatus.

Pressure Gauges.—Standard gauges were used for pressure indications, and were tested from time to time on a Crosby dead weight gauge tester.

Thermometers.—A Hicks thermometer was used for feed water temperature, and placed in the feed water tank from which the pumps drew. The errors of all thermometers used were determined by comparison with certified Hicks standard thermometers. A Hohman and Maurer gas filled mercurial thermometer was used for flue gas temperature determinations.

METHOD OF CONDUCTING TESTS AND MAKING MEASUREMENTS: LOG AND CALCULATIONS FOR ONE TRIAL.

METHOD OF CONDUCTING TRIALS

The trials were conducted in accordance with the system recommended by the Committee of the American Society of Mechanical Engineers in their code of 1909¹. The total number of tests made (including those made for comparison with standard coal) was seventy-two, and it was found impossible to obtain the samples of coal from the east and from the west of Canada with sufficient rapidity and regularity to enable all of these to be made in one season. Thirty-nine of the tests were, therefore, made during the summer of 1907, thirty-seven during the summer of 1908, and the remainder subsequently.

The equipment of the boiler room having been described in the previous section, the following paragraphs give a brief account of the organization and methods adopted in making the tests.

DUTIES OF STAFF²

Four observers and one fireman were employed in each trial. The observers' duties were:—

Observer No. 1.—Conducted the trial, observed and directed the working of the fire, entering all events in the log sheet, weighed coal fired and ash and clinker removed. Took samples of coal and refuse.

Observer No. 2.—Took charge of weighing feed water, adjusted the level of water in feed tanks and in boiler, and superintended the working of the feed pump.

Observer No. 3. (Chemist).—Was responsible for sampling and analysis of flue gases.

Observer No. 4.—Read all pressures and temperatures, observed and recorded steam dryness, intensity of draft, and damper opening.

The fireman, in addition to firing as directed, attended to the forced draft apparatus and steam jet under the grate (when used); he also assisted in handling the coal to and from the scales.

Most of the observations were taken at 15 minute intervals.

¹ See Trans. A.S.M.E., Vol. 21, pp. 34-111; also Vol. 6, pp. 256-267.

² See Vol. I, pp. 4 and 5.

GENERAL PRECAUTIONS

Before each trial the boiler tubes and headers were blown as clean as possible, and the grate and brickwork freed from clinker, etc. The brickwork was in every case thoroughly heated before commencing a test. Before each series of trials the brickwork of the boiler was put in thorough repair, and the boiler and connexions were tested for tightness.

WEIGHING AND HANDLING COAL

From each lot of coal, after examination, treatment, mixing, and sampling by the staff in charge of the chemical and coal-washing portion of the investigation, a sufficient quantity was taken, bagged, and delivered to the boiler room. The means of identification for the information of the boiler room staff was a label affixed to each bag, giving the serial number of the coal. (See Column 2 in Table IV.) The amount of coal in all but one or two cases was enough not only for the ten-hour trial, but also for a preliminary run of a length sufficient to give the staff an opportunity of finding an appropriate method of firing and working the coal in the furnace.

Starting with a banked fire from the previous day's run, the tubes were cleaned, the fire was broken out, and firing was commenced with the coal to be tested. When in proper condition, and generally about one hour before commencing the test, this fire was burned down and cleaned, the trial being actually started when the clean fire was in a suitable condition to be judged.

During the trial the coal was fired, and the fire sliced, broken up, and cleaned as found necessary. In every case, however, the fire was again cleaned about one hour before the conclusion of the trial, and was then worked so as to bring it at the end of the test into as nearly as possible the same condition as at the beginning.

The coal was emptied from the sacks into a wooden shovelling bin mounted on scales and holding about 420 pounds. The time at which this bin was emptied was noted as the time at which a certain weight of coal had been fired. Check weights were taken every half hour.

After emptying each sack a sample of about 20 pounds was taken from the bin and placed in a special sample box. The contents of the sample box were afterwards forwarded to the Chemical Department for analysis. On this analysis the figures for the percentage of moisture (Column 11, Table IV) were based.

The whole of the ash and clinker formed during the trial was weighed and forwarded to the Chemical Department for analysis.

MEASUREMENT OF WATER

Water from the city mains was admitted as required into a weighing tank mounted on scales. After weighing each tankful of water it was discharged into the feed tank from which the feed pump drew. A wooden T gauge in this feed tank marked a level to which the water was brought at the commencement and also at the end of the trial. The gauge

glasses on the boiler were, of course, also marked, and allowance made for any difference in level at the beginning and end of each interval.

The feed water scales, as well as those used for coal weighing, were carefully tested with standard weights before each series of trials and at intervals during the progress of the work.

TEMPERATURE OF FEED WATER

The temperature of the feed water was taken by a Hicks' thermometer immersed in the water in the feed tank. With the low feed temperatures actually used, there was no perceptible change in temperature while the water was pumped to the boiler.

QUALITY OF STEAM.

Pressure.—The pressure of the steam at the calorimeter was read upon a standard Schaeffer and Budenberg pressure gauge. This gauge was carefully tested from time to time upon a Crosby standard gauge tester, and its error determined.

Dryness.—The amount of moisture present in the steam was computed from observations taken with a Peabody throttling calorimeter. The pipe leading to the calorimeter was taken directly from the steam drum of the boiler, and steam was passed through the calorimeter continuously during the test.

DRAFT

The draft was measured by means of U tube gauges filled with water. These tubes were placed in order to record the draft:—

- (a) under the grate,
- (b) over the grate,
- (c) at the back of the boiler, close to the damper.

FLUE GASES

The temperature of the flue gas was observed in the opening to the main flue (at **E** Fig. 33) close to the damper. The thermometer used was a Hohman and Maurer gas filled mercury thermometer, which was adjusted to read correctly at 212° F.

A portion of the flue gas was withdrawn continuously through a sampling pipe leading from a point at the back of the boiler close to the damper opening, the suction being produced by means of a water aspirator. Sample bottles were filled from a tee on this sampling pipe. The sampling apparatus has already been described in detail (see p. 17).

A sample of about 300 c.c. was taken from the sampling pipe every fifteen minutes for analysis while the trial proceeded. As the results of these analyses were used for controlling the method of firing and treatment of the fire, these samples as a rule were not taken while the fire was being cleaned or when it was in defective condition. The loss of heat due to the escape of hot flue gas, as given in Column 39, Table IV, will, therefore, be rather less than the true

amount. The figures in columns 36 and 37 will, however, not be affected by this circumstance. For full details of methods of chemical analysis in the boiler room see Part IX of this Volume.

RESULTS OF BOILER TRIAL NO. 58

In order to illustrate the methods adopted and the results obtained during the tests the complete log of one trial is annexed, together with the resulting calculations worked out in detail. This trial was made on a sample of coal from Cape Breton, and was taken as being fairly representative.

The log is followed by two forms, the "Summary of Observations" (Form A) and the "Summary of Results" (Form B); most of the items in these are self-explanatory. A complete series of such summaries and logs for all the trials will be found in Vol. IV of this report.

Explanations as to the methods of calculation by which the figures in Form B were obtained are given below, the calculations applying, of course, to trial No. 58 for which the log and summaries are given here.

LOG OF EVENTS

Trials of No. 2 Babcock and Wilcox Boiler with No. 36 coal.

Date, July 31, 1908. Trial number, G. C. T. 58.

Observations of general conditions.

Observer, J. Blizzard.

NOTES.—No. 1, B. and W. boiler working. Weather close and warm. Coal of medium size, not much small stuff. Fair amount of slate-like substance.

General Notes.

Time.

- 7.30 a.m. Fire cleaned, and made up with No. 36 coal. Pressure 85 pounds per square inch.
- 7.50 Tubes blown.
- 8.40 Started trial. Fire 2" well burnt through; flame at back. Keeping thin fire (3"). This coal burns with much flame and smoke.
- 9.30 Grill half open. Does not coke at all.
- 10.05 Grill wide open.
- 12.10 p.m. Slice bar put into fire and found some hard clinker on bars. Did not remove. So far rake has not been put into fire, coal not coking at all.
- 2.27 Sliced fire.
- 3.27 Sliced fire, removed 40 pounds clinker. Clinker when hot seems to be in plastic cakes spread over grate.
- 5.30 Fire cleaned. Removed 70 pounds clinker in large slabs which harden on cooling. Bluish in colour. Not very difficult to remove, but coal could not be used on shaking grate.
- 6.40 Trial finished, fire as at start. 52 pounds ash raked from ash pit. Blow off examined and found tight.

Ash and Clinker

	Tare	Gross	Net	
3.27 p.m.	—	...	40	Fire sliced
5.30 p.m.	75	145	70	Fire cleaned
				110 pounds clinker
6.00 p.m.	75	127	52	pounds ash raked from beneath bars.
				162 pounds ash and clinker.

Coal Fired

Trial on No. 2 Babcock and Wilcox boiler with No. 36 coal.

Date, July 31, 1908. Trial number, G. C. T. 58.

Observations on coal.

Observer, J. Blizard.

Notes.—Coal fired before trial commenced, 7.32 to 8.40 = 246 lbs.

TABLE I
Detailed Record of Coal Fired.

Time	Nos. of Sacks	COAL BIN			Coal Fired in Interval	Total Coal Fired
		Tare	Gross	Net		
a.m.						
8.40	2 (cont'd)	132	182	50	—	—
8.45	3, 4, 5	132	549	417	50	50
9.15		328		221	271
9.45		195		133	404
9.55	132	552	420	63	467
10.25		406		146	613
10.55		254		152	765
11.15	6, 7	132	451	319	122	887
11.45		329		122	1009
p.m.						
12.15		174		155	1,164
12.17	8, 9, 10	132	532	400	42	1,206
12.45		369		163	1,369
1.15		196		173	1,542
1.30	11, 12, 13	132	541	409	64	1,606
2.0		436		105	1,711
2.30		286		150	1,861
3.0		185		101	1,962
3.10	14, 15	133	462	329	53	2,015
3.40		328		134	2,149
4.15	16, 17	132	566	434	195	2,344
4.45		416		150	2,494
5.15		312		104	2,598
5.30	(Before cleaning)		290		22	2,620
5.45	18	132	408	276	158	2,778
6.15		265		143	2,921
6.40		232		33	2,954

TABLE II

TRIALS OF No. 2. BABCOCK AND WILCOX BOILER WITH No. 36 COAL.

Date, July 31, 1908.

Trial Number, G. C. T. 53.

OBSERVATIONS OF FEED WATER PRESSURES, AND TEMPERATURES.

Boiler gauge subtract 2 lbs. from reading.

Calorimeter gauge correct.

Calorimeter therm. correct. No. 65100, 0°-400° F.

Barometer at start 29.64, at finish 29.54.

Corrections not allowed for on sheets.

Feed therms. Hicks Nos. 15706

and 15701 sub. 0.5° F.

Air therm. sub. 1° F.

Time	Gross	Tare	Water Dis- charg- ed	Lower Tank Rdg.	Gauge Glass Rdg.	Lbs. Evaporation		Boiler Press. Lbs. per Sq. In.	Cal. Press. Lbs. per Sq. In.	Cal. Temp. °F.	Draught in Ins. Water			Damper Opening Ins.	Boiler Room Temp. °F.	Feed Temp. °F.	Flue Gas Temp. °F.
						In In- terval	Per Min.				At Damper	Above Grate	Below Grate				
8.40				1850	310			118	15.2	290	0.24	0.16	0.02	24"	90	72.5	570
8.55				1280	360	520	34.7	114	14.5	290	0.24	0.16	0.02	24"	90	72.5	560
9.10	539	131	408	1340	330	378	25.2	124	16.2	293	0.26	0.20	0.02	24"	90	73.0	575
9.25	539	132	407	1170	370	537	35.8	115	15.0	290	0.27	0.18	0.02	24"	90	73.0	570
9.40	542	128	414	1180	320	454	30.3	124	16.0	294	0.26	0.16	0.02	24"	91	73.0	620
9.55	537	129	408	1030	440	438	29.2	120	15.4	293	0.26	0.16	0.02	24"	91	73.0	580
10.10	537.5	128	409.5	1100	250	529.5	35.3	124	16.1	294	0.26	0.20	0.02	24"	91	73.5	620
10.25	542	128	414	950	320	494	32.9	125	16.4	294	0.27	0.18	0.02	24"	91	73.5	630
10.40	539	129	410														
	540	127.5	412.5	1160	360	572.5	38.2	122	16.0	294	0.27	0.18	0.02	24"	91	73.5	640
10.55	539	127.5	411.5	1210	290	431.5	28.8	123	16.1	294	0.28	0.18	0.02	24"	92	73.5	625
11.10	540	127.5	412.5	1020	420	472.5	31.5	120	15.3	292	0.28	0.18	0.02	24"	91	73.5	610
11.25	538.5	128	410.5	1000	370	480.5	32.1	124	16.3	293	0.28	0.18	0.02	24"	92	73.5	580
11.40	541	128	413	1020	350	413	27.5	124	16.1	294	0.28	0.18	0.02	24"	92	73.5	590
11.55	540	127	413	940	430	413	27.5	122	15.8	293	0.28	0.18	0.02	24"	92	73.5	585
12.10	537.5	128	409.5														
	539	129	410	1380	340	469.5	31.3	119	16.3	293	0.28	0.18	0.02	24"	92	73.5	635
12.25	541	128	413	1280	330	523	34.9	124	16.2	294	0.28	0.18	0.02	24"	91	73.5	600
12.40	539	127.5	411.5	1090	440	491.5	32.8	125	16.4	294	0.28	0.18	0.02	24"	91	73.5	640
12.55	538	127	411	1100	420	421	28.1	123	16.2	294	0.28	0.18	0.02	24"	91	73.5	600
1.10	539	127	412	1070	390	472	31.5	125	16.4	294	0.28	0.18	0.02	24"	92	74.0	700
1.25	541	128	413	1050	340	483	32.2	121	15.6	294	0.28	0.18	0.02	24"	91	73.5	620
1.40	539	128.5	410.5	980	410	410.5	27.4	125	16.4	294	0.28	0.18	0.02	24"	91	73.5	610
1.55	538.5	127.5	411														
	550	130	420	1350	350	521	34.7	123	16.2	294	0.28	0.18	0.02	24"	91	73.5	620
2.10	538	133	405	1260	460	385	25.7	125	16.4	294	0.26	0.18	0.02	24"	92	73.5	560
2.25	538	128.5	409.5	1340	350	439.5	29.3	122	15.6	294	0.26	0.18	0.02	24"	96	74.0	570
2.40	538	129	409	1280	370	449	29.9	116	15.0	292	0.26	0.18	0.02	24"	92	74.0	660
2.55	537	127.5	409.5	1240	370	449.5	30.0	117	15.2	290	0.26	0.18	0.02	24"	92	74.0	630
3.10	538	128	410	1300	340	380	25.3	113	14.2	290	0.26	0.18	0.02	24"	92	74.5	600
3.25	538	127	411	1290	390	371	24.7	117	15.2	290	0.26	0.18	0.02	24"	92	74.5	630
3.40	537.5	128.5	409	1330	460	299	19.9	125	16.4	294	0.30	0.20	0.02	24"	93	75.0	780
3.55	540	130	410	1300	370	530	35.3	118	15.3	291	0.30	0.20	0.02	24"	92	75.0	720
4.10	539.5	128	411.5	1230	360	491.5	32.8	120	15.8	294	0.30	0.20	0.02	24"	92	75.0	710
4.25	538	128	410	1180	360	460	30.7	124	16.1	294	0.30	0.20	0.02	24"	92	75.0	650
4.40	540	129	411	1100	340	511	34.1	125	16.4	294	0.28	0.20	0.02	24"	94	75.0	640
4.55	540	128	412	1060	380	412	27.5	125	16.4	293	0.28	0.20	0.02	24"	92	75.0	640
5.10	540.5	128	412.5	1060	360	432.5	28.9	123	16.0	292	0.28	0.20	0.02	24"	90	75.0	610
5.25	541	130	411	1030	420	381	25.4	120	15.6	290	0.28	0.20	0.02	24"	90	75.0	580
5.40	540	129	411	1210	320	331	22.1	95	11.0	286	0.28	0.20	0.02	24"	98	75.0	540
5.55	537	127.5	409.5	1210	380	349.5	23.3	100	12.3	281	0.26	0.18	0.02	18" at 5.55	90	75.0	520
6.10	540	131	409	1340	380	279	18.6	119	15.4	290	0.26	0.18	0.02	18"	89	75.0	530
6.25	541	133	408	1390	350	388	25.9	125	16.4	294	0.28	0.20	0.02	24" at 6.10	90	75.0	600
6.40	537	129	408	1390	330	428	125	16.4	294	0.30	0.20	0.02	24"	89	75.0	710
Total						17,691.5											
Mean						120.4	15.6	292.3	-0.28	-0.18	-0.02	91.5	74.0	616	
Corr.						118.4	15.6	292.3	90.5	73.5	616	

Gas Analysis

Trial on Babcock and Wilcox No. 2 boiler with No. 36 coal.

Date, July 31, 1908. Trial number, G. C. T. 58.

Observations of flue gas analysis

Observer, E. J. Conway.

TABLE III
Detailed record of Gas Analysis.

Time	CO ₂	CO ₂ +O ₂	O ₂	CO ₂ +O ₂ +CO	CO	N	Remarks
8.40	10.8	16.6	5.8	18.4	1.8	81.6	
9.10	10.1	17.3	7.2	19.0	1.8	81.0	
9.40	10.2	19.0	8.8	19.4	0.4	80.6	
10.10	12.0	18.5	6.5	18.7	0.2	81.3	
10.40	9.2	19.5	10.3	19.7	0.2	80.3	
11.10	9.5	18.3	8.8	19.4	1.1	80.6	
11.40	8.9	19.0	10.1	19.9	0.9	80.1	
12.10	11.2	16.6	5.4	19.3	2.7	80.7	
12.40	10.9	16.3	5.4	19.2	2.9	80.8	
1.10	11.6	17.1	5.5	18.6	1.5	81.4	
1.40	9.2	18.1	8.9	19.7	1.6	80.3	
2.10	9.0	15.0	6.0	19.5	4.5	80.5	
2.40	9.0	19.0	10.0	19.2	0.2	80.8	
3.10	7.8	19.9	12.1	19.9	0.0	80.1	
3.40	12.5	17.8	5.3	19.2	1.4	80.8	
4.10	8.6	18.7	10.1	19.3	0.6	80.7	
4.40	10.5	18.5	8.0	19.0	0.5	81.0	
5.10	8.1	19.5	11.4	19.7	0.2	80.3	
5.45	8.4	17.9	9.5	18.8	0.9	81.2	After cleaning fire.
6.10	9.0	17.8	8.8	19.0	1.2	81.0	
Mean Value	9.8	8.2	1.2	80.8	

BOILER TRIAL NO. G. C. T. 58.—FORM A.

Summary of Observations

Date, July 31, 1908. Boiler B. & W. No. 2 at McGill University.
Commenced 8.40 a.m. Ended 6.40 p.m. Duration 600 minutes.

General—

1. Method of stoking—hand, spreading on alternate sides.
2. Kind of draft—natural.
3. Condition of boiler and date of cleaning—thoroughly cleaned May 1908.
4. Tubes cleaned, 7.50 a.m.
5. Fire cleaned, 7.30 a.m., 5.30 p.m.

Fuel—

6.	Kind of coal—No. 36, Dominion Coal Co., Sydney, No. 7 mine.	
7.	Analysis of dry coal by weight (%), C = 76.7, H = 5, S = 2.4, N = 1.6, O ₂ = 8.4, ash = 5.9.	
8.	Calorific value of dry coal B.T.U. per lb.	13,860
9.	Moisture in coal as fired. %	2.7
10.	Weight of coal fired (lbs.)	2,954
11.	Combustible matter in ash and clinker %	14.9
12.	Weight of clinker (lbs.)	110
13.	Weight of ash (lbs.)	52

Air and Flue Gas—

14.	Air pressure under fire (inches of water),	-0.02
15.	“ “ above fire “ “ “	-0.18
16.	“ “ at damper “ “ “	-0.28
17.	Amount of damper opening, full, $\frac{3}{4}$ open 5.55 p.m. to 6.10 p.m.	
18.	Temperature of air in boiler house (°F.)	90.5
19.	Flue temperature (°F.)	616
20.	Analysis of dry flue gas by volume %, CO ₂ = 9.8, O = 8.2, CO = 1.2, N = 80.8.	

Water and Steam—

21.	Temperature of feed water (°F.)	73.5
22.	Total weight of feed water (lbs.), corrected for difference of level.	17,691.5
23.	Water level in gauge at start (inches).	3 $\frac{3}{8}$ "
24.	“ “ “ “ “ finish (inches).	3 $\frac{1}{2}$ "
25.	Correction for difference of level (lbs.), included above.	-20
26.	Steam pressure by gauge (lbs. per sq. in.)	118.4
27.	Barometer reading (inches),	29.59
28.	Pressure in calorimeter by gauge (lbs. per sq. in.),	15.6
29.	Temperature in calorimeter (°F.)	292.3

Notes—

Coal burns with much flame and smoke. Grill open over fire. Not coking at all. Clinker bluish, plastic when hot; easily removed, but coal could not be used on a shaking grate. Fire cleaned out once, sliced three times.

Weather close and warm.

		%
Proximate analysis	{ Fixed carbon.	57.6
	{ Volatile matter.	36.5
	{ Ash.	5.9

Signed, JOHN BLIZARD.

BOILER TRIAL NO. G. C. T. 58—FORM B.

Summary of Results

Trial on Babcock and Wilcox No. 2 boiler at McGill University.

To determine quality of coal.

Kind of fuel, No. 36 coal. Kind of furnace, fixed bars, 30 per cent air space.

Method of starting and stopping test, alternate (A. S. M. E.)

Grate surface (square feet), 16·79. Water heating surface (square feet), 639.

Superheating surface (square feet), nil.

Barometer at start, 29·64, at finish, 29·54, mean 29·59.

Total Quantities—

1. Date of trial.	31/7/08
2. Duration of trial (hours).	10·0
3. Weight of coal as fired (lbs.).	2,954
4. Percentage of moisture in coal as fired (%).	2·7
5. Total weight of dry coal, fired (lbs.).	2,874
6. Total ash and refuse (lbs.).	162
7. Percentage of ash and refuse in dry coal (%), (a) from analyses, 6·9, (b) weighed.	5·64
8. Total weight of combustible consumed (lbs.), from analyses	2,676
9. Total weight of water fed to the boiler corrected for difference of level (lbs.).	17,691·5
10. Equivalent water evaporated into dry steam from actual feed water temperature and boiler pressure (lbs.). . . .	17,620
11. Equivalent water evaporated into dry steam from and at 212° F. (lbs.).	20,920

Hourly Quantities—

12. Dry coal fired per hour (lbs.).	287·4
13. Dry coal per sq. ft. of grate surface per hour (lbs.).	17·1
14. Water evaporated per hour corrected for quality of steam (lbs).	1,762
15. Equivalent evaporation per hour from and at 212° F. (lbs.).	2,092
16. Equivalent evaporation per hour from and at 212° F. per sq. ft. of water heating surface (lbs.).	3·27

Average Pressures, Temperatures, etc.—

17. Steam pressure gauge (lbs. per sq. in.).	118·4
18. Temperature of feed water entering boiler (deg. F.).	73·5
19. " " escaping gases from boiler (deg. F.).	616
20. Pressure of draft between damper and ash-pit (ins. of water).	0·26
21. Percentage of moisture in steam.	0·6

Diagram, typical of the 72 boiler trial curve sheets, in Appendix II, Vol. IV.

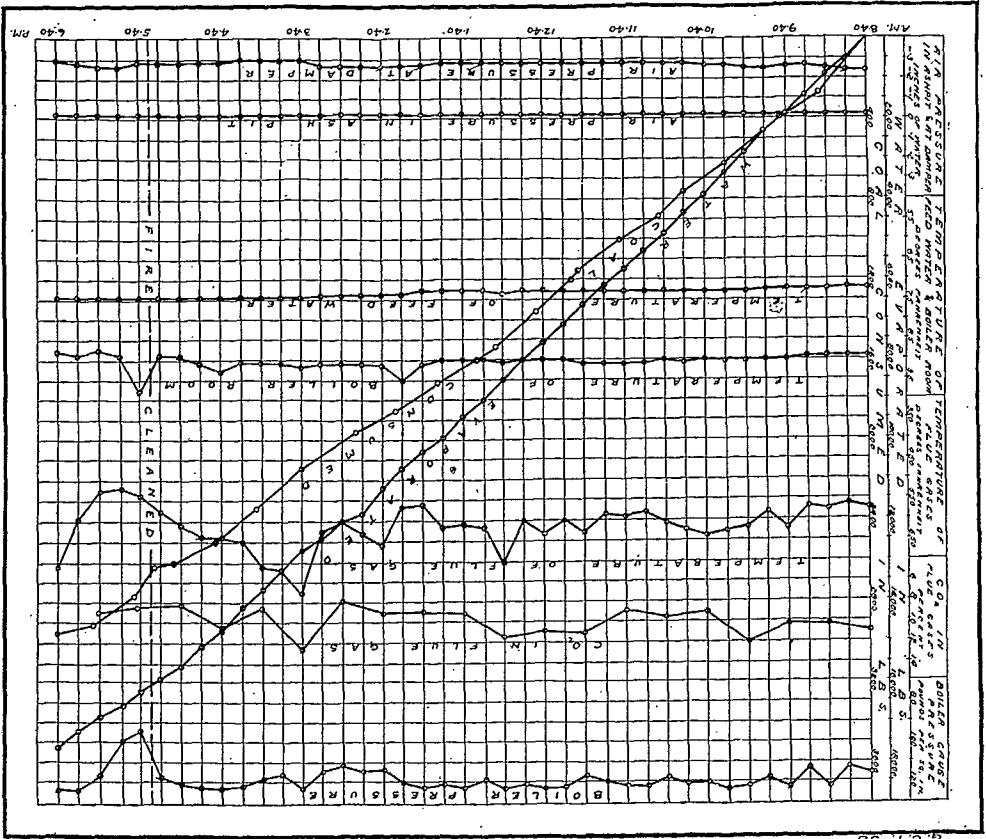

Horse-power—

22. Horse-power developed (Item 15 ÷ 34½)	60.5
23. Builders' rated horse-power.	60
24. Percentage of builders' rated horse-power developed.	101

Economic Results—

25. Water apparently evaporated under actual conditions per lb. coal as fired (Item 9 ÷ Item 3)	5.99
26. Equivalent evaporation from and at 212° F. per lb. coal as fired (Item 11 ÷ Item 3)	7.08
27. Equivalent evaporation from and at 212° F. per lb. of dry coal (Item 11 ÷ Item 5)	7.27
28. Equivalent evaporation from and at 212° F. per lb. of combustible consumed (Item 11 ÷ Item 8)	7.83

Efficiency—

29. Calorific value of dry coal per lb. (B.T.U.)	13,860
30. " " of the combustible per lb. (B.T.U.)	14,740
31. Efficiency of boiler (based on combustible consumed (%))	51.4
32. " " " including grate (based on dry coal) (%)	50.6

Flue Gases—

33. Dry flue gas per lb. carbon (from gas analyses) (lbs.)	22.6
34. " " " " " combustible consumed (from gas analysis) (lbs.)	18.6
35. Dry flue gas per lb. dry coal (from gas analyses) (lbs.)	17.3
36. Proportion of heat of fuel in escaping dry flue gases (%)	15.7

Signed, JOHN BLIZARD.

CALCULATIONS

Calculations for Trial No. 58, leading to Figures given in the Summary of Results—Form B.

Items Nos. 1 to 4B¹ require no explanation.

Item 5B.—Total weight of dry coal fired. This is found from the total weight of coal fired, less weight of moisture, and is equal to:—

Total coal fired (Item 3B) × (1—moisture per pound coal, from Item 4B)
= 2,954 × (1—0.027) = 2,874 pounds

Item 7B.—Percentage dry coal unconsumed.

The refuse withdrawn from the ashpit always contains a proportion of combustible matter in addition to the ash, or really incombustible part of the fuel. A certain amount of the ash in the coal burnt is always lost by being carried off in the form of dust by the flue gases or otherwise. The actual weight of refuse taken from the ashpit is, therefore, less than the weight of that part of the fuel which is not consumed. Item 7A gives the proportion of the dry coal which is not consumed, estimated from the analysis of the refuse

¹ Items taken from the "Summary of Observations" are marked A (Item 12A, etc.), those from the "Summary of Results" are marked B.

removed; Item 7B gives the proportion as actually weighed, and is, of course, less than 7A. In calculations based on combustible consumed, 7A has been used throughout.

Item 7A.—The material removed from the ashpit during the trial contained 14.9 per cent (Item 11A) of combustible matter and 100–14.9 or 85.1 per cent of real ash. But the dry coal as analysed contained 5.9 per cent of real ash, and, therefore, must have contained $5.9 \times \frac{100}{85.1}$ or 6.9 per cent of refuse consisting of 14.9 per cent of combustible matter and 85.1 per cent of ash. Also 100–6.9 or 93.1 per cent of the dry coal fired was actually consumed as combustible.

Item 7B.—The percentage as determined from the weight of refuse actually taken from ashpit is:—

$$\frac{\text{weight of clinker (Item 12A) + weight of ash (Item 13A)}}{\text{total weight of dry coal (Item 5 B)}} \times 100$$

$$= \frac{100 + 52}{2874} \times 100 = 5.6$$

As just explained, this is less than Item 7A, on account of loss of ash.

Item 8B.—Total weight of combustible consumed.

This is evidently:—

$$\text{Total weight of dry coal (Item 5 B)} \times \frac{(100 - \text{Item 7A})}{100} = 2874 \times \frac{93.1}{100}$$

$$= 2676 \text{ lbs.}$$

Item 10B.—Equivalent water evaporated into dry steam, from actual feed water temperature, and at boiler pressure (pounds).

The feed water pumped into the boiler was not all actually evaporated, since steam withdrawn from the steam drum of the boiler was found to contain unevaporated moisture. A correction must, therefore, be applied.

We have as data:—

Item 26A—Steam pressure in boiler by gauge, lb. per sq. in.	118.4
Item 27A—Barometric pressure per sq. in.	14.5
	<hr/>
Absolute steam pressure lb. per sq. in.	132.9
Latent heat of steam at this pressure (from steam tables) B.T.U. . . .	867.5
Heat of the liquid from 32° (from tables)	320.8
	<hr/>
Total heat of steam at 132.9	1188.3
Item 28A—Steam pressure in calorimeter by gauge, lb. per sq. in. . . .	15.6
Barometric pressure, lb. per sq. in.	14.5
	<hr/>
Absolute steam pressure lb. per sq. in.	30.1
	<hr/>

Total heat of steam at this pressure (from steam tables)	
B.T.U.	1158.3
Temperature of saturated steam at 30.1 lb. per sq. in. (from tables) deg. F.	250.4
Item 29A—Actual temperature in calorimeter deg. F.	292.3
	<hr/>
Superheat in calorimeter deg. F.	41.9
	<hr/>

Now taking 0.6 as the specific heat of superheated steam we have: total heat of 1 pound steam at 30.1 pounds per square inch superheated 41.9° F. = 1158.3 + (0.6 × 41.9) = 1158.3 + 25.1 = 1183.4 B.T.U. This is the same as the total heat of one pound of wet steam before entering calorimeter, since no heat is lost or gained. Hence, if the steam is passed into the calorimeter without loss or gain of heat, and contained originally x per cent of moisture, we have

$$320.8 + \frac{100 - x}{100} \times 867.5 = 1183.4.$$

from which $x = 0.6$ per cent. (Table IV, Col. 27).

Item 21A.—Again, feed water temperature was 73.5° F. and, from steam tables, one pound of water requires 41.5 B.T.U. to warm it from 32° to 73.5°; hence,

Heat given to each pound of feed water at 73.5° to form one pound of wet steam of total heat 1183.4 B.T.U. = 1183.4 - 41.5 = 1141.9 B.T.U.

But if the boiler steam had been dry and saturated at a pressure of 132.9 pounds per square inch absolute, its total heat per pound would have been 1188.3 B.T.U. and the heat given to each pound of feed water would have been 1188.3 - 41.5 = 1146.8 B.T.U. Hence, the actual heat given to 17,691 pounds of feed water, converting them into steam still containing 0.6 per cent of moisture, would have completely evaporated, or turned into dry steam

$$17691 \times \frac{1141.9}{1146.8} = 17,620 \text{ pounds of feed water.}$$

This figure is, therefore, taken as the water actually evaporated corrected for moisture in steam.

Item 11B.—Equivalent water evaporated into dry steam from and at 212°.

From previous calculation the heat given to one pound of feed water at 73.5° and forming a pound of steam of the quality actually delivered by the boiler was found to be 1141.9 B.T.U. But if steam had been formed from water at 212° and at atmospheric pressure, the heat required per pound would have been 966 B.T.U.

The weight of dry steam evaporated from and at 212°, which would require the same expenditure of heat as the 17691 pounds of feed water actually fed to the boiler and converted into wet steam, is, therefore,

$$17691 \times \frac{1141.9}{966} = 20920 \text{ lbs.}$$

Item 12B.—Dry coal fired per hour.

$$\text{Item 5 B} \div \text{Item 2 B} = 2874 \div 10 = 287.4 \text{ pounds.}$$

Item 13B.—Dry coal per square foot of grate surface per hour.

$$\text{Item 12 B} \div 16.79 = 287.4 \div 16.79 = 17.1 \text{ pounds.}$$

Item 14B.—Water evaporated per hour, corrected for quality of steam.

$$\text{Item 10 B} \div \text{Item 2 B} = 17620 \div 10 = 1762 \text{ pounds.}$$

Item 15B.—Equivalent evaporation per hour from and at 212°.

$$\text{Item 11 B} \div \text{Item 2 B} = 20920 \div 10 = 2092 \text{ pounds.}$$

Item 16B.—Equivalent evaporation per hour from and at 212° per square foot of water heating surface.

$$\text{Item 15 B} \div 639 = 2092 \div 639 = 3.27 \text{ pounds.}$$

The Items 17 to 20B require no explanation. The method of obtaining Item 21B (moisture in steam) has already been given (see under Item 10). The simple calculations for Items 25 to 28B are given on the sheet.

Item 29B.—Calorific value of dry coal per pound. This quantity was determined in each case in a bomb calorimeter, and full details of the calorimetric tests will be found in Part IX of this Volume.

Item 30B.—Calorific value of the combustible per pound.

Item 7A shows that 94.1 per cent of the dry coal fired was combustible, hence calorific value of one pound of combustible

$$= \frac{100 \times \text{calorific value of 1 lb. dry coal}}{94.1} = \frac{100 \times 13860}{94.1} = 14740 \text{ B.T.U.}$$

Item 31B.—Efficiency of boiler (based on combustible consumed).

This efficiency is the ratio of the heat actually used in warming and evaporating water, to the heat obtained from, and rendered available by, the furnace.

From Item 28 B for each pound of combustible consumed there was given to the water in the boiler an amount of heat equivalent to the evaporation of 7.83 pounds of water from and at 212°, hence

$$\text{Efficiency} = \frac{\text{Item 28B} \times 966}{\text{Item 30B}} = \frac{7.83 \times 966}{14740} = 51.4 \text{ per cent.}$$

Item 32B.—Efficiency of boiler including grate (based on dry coal).

This efficiency is the ratio of the heat actually used in warming and evaporating water, to the heat which would be obtained by the perfect combustion of the coal fired, allowing for the moisture present in the coal.

From Item 27 B an amount of heat equivalent to the evaporation of 7.27 pounds of water from and at 212° was obtained from the combustion of each pound of dry coal and utilized, hence

$$\text{Efficiency} = \frac{\text{Item 27B} \times 966}{\text{Item 29B}} = \frac{7.27 \times 966}{13860} = 50.6 \text{ per cent.}$$

Item 33B.—Dry flue gas per pound of carbon (from gas analyses).

Item 20A gives the gas analyses by volume. The relative weights of the constituent gases referred to hydrogen as unity are taken as

Carbon dioxide.	22
Oxygen.	16
Carbon monoxide.	14
Nitrogen, etc.	14

Thus the weight of 100 volumes of flue gas, containing n_1 volumes of carbon dioxide, n_2 volumes of oxygen, n_3 of carbon monoxide, and n_4 of nitrogen and other residual gases, would be given by the expression

$$\frac{22n_1 + 16n_2 + 14(n_3 + n_4)}{100}$$

if referred to the weight of 100 volumes of hydrogen.

Now carbon dioxide contains $\frac{12}{44}$ of its weight of carbon, and carbon monoxide contains $\frac{12}{28}$ of its weight of carbon, so that the weight of carbon in 100 volumes of flue gas will be

$$\frac{22n_1 \times \frac{12}{44} + 14n_3 \times \frac{12}{28}}{100} = \frac{6(n_1 + n_3)}{100}$$

times the weight of 100 volumes of hydrogen. Hence, the weight of flue gas containing one pound of carbon will be

$$\frac{\text{weight of 100 vols. flue gas}}{\text{weight of carbon in 100 vols. flue gas}} = \frac{22n_1 + 16n_2 + 14(n_3 + n_4)}{6(n_1 + n_3)}$$

$$= \frac{11n_1 + 8n_2 + 7(n_3 + n_4)}{3(n_1 + n_3)} \text{ pounds}$$

Here $n_1 = 9.8$; $n_2 = 8.2$; $n_3 = 1.2$; $n_4 = 80.8$ and

$$\text{Item 33B} = \frac{(11 \times 9.8) + (8 \times 8.2) + 7(1.2 + 80.8)}{3(1.2 + 9.8)} = \frac{747.4}{33} = 22.6 \text{ pounds}$$

Item 34B.—Dry flue gas per pound of combustible consumed.

$$\text{This is given by } \text{Item 33B} \times \frac{\text{Total dry coal used}}{\text{Total combustible consumed.}}$$

$$= \text{Item 35} \times \frac{\text{Item 5B}}{\text{Item 8B}} = 17.3 \times \frac{2874}{2676}$$

$$= 18.6 \text{ pounds.}$$

Item 35B.—Dry flue gas per pound of dry coal.

This is given by $\text{Item 33B} \times \text{carbon per pound of dry coal}$

$$= \text{Item 33} \times \frac{\text{Item 7A}}{100}$$

$$= 22.6 \times 0.767 = 17.3 \text{ pounds.}$$

Item 36B.—Proportion of heat of fuel in escaping dry flue gases.

This is the ratio of the heat carried away by the flue gases, to the heat which would be developed by the complete combustion of the amount of dry coal fired.

The air entering the furnace and combining with the fuel leaves the boiler at the temperature given by Item 19A, the entering temperature being given

by Item 18A. Neglecting the difference between the weight of air entering and the weight of flue gas leaving the boiler, and taking 0.24 as the mean specific heat of the gas, each pound of flue gas carries away

$$0.24 \text{ (Item 19A - Item 18A) B.T.U.}$$

Therefore, for each pound of dry coal the heat carried away is

$$\begin{aligned} & \text{Item 35B} \times 0.24 \times (\text{Item 19A} - \text{Item 18A}) \\ & = 17.3 \times 0.24 (616 - 90.5) = 2180 \text{ B.T.U.} \end{aligned}$$

Expressed as a proportion of the heat value of a pound of dry coal (Item 29B or 8A) this becomes $\frac{2180}{13860} \times 100 = 15.7$ per cent.

REMARKS ON BOILER TRIALS AND THEIR RESULTS

VALUE OF COAL

The actual worth of a given fuel for steam purposes, as has been already pointed out, depends primarily on the amount of heat which can be utilized in the boiler as the result of a given expenditure for fuel, and, secondarily, on the labour and maintenance costs resulting from the use of that fuel. In testing a series of coals it is thus impossible to state definitely their actual or even relative values for steam purposes, unless complete information as to cost of fuel and labour is available, and in the present instance all that can be done is to discuss the leading characteristics of the coals tested, regardless of cost, but taking into consideration the evaporative power and the operating conditions found in working with each coal.

The figures on which the following notes are based will be found in Table IV (Summary Record of Boiler Tests), and it will be observed that the coals are there arranged in geographical order. The Sydney coals are given first, followed by the coals from Inverness and Pictou counties, Nova Scotia, from the Springhill and Joggins coal fields in Nova Scotia, and from the Grand Lake coal field in New Brunswick. The next group is from the west, and includes the bituminous coals, lignites, and lignitic coals of Saskatchewan and Alberta; the Crowsnest coals of British Columbia follow, and next in order are the coals from the Cascade coal field, Alberta; the series is concluded by the remaining British Columbia coals, including those from Vancouver island. Samples from the Yukon could not be included in the series of boiler trials, as a sufficient quantity of coal was not available.

COMPOSITION OF COALS

In the samples on which boiler trials were made, the proportion of ash varied from 2.7 per cent, in a washed Cape Breton coal, to 19.8 per cent, in one of the Alberta coals. Volatile matter ranged from 12.5, in a washed coal from the Cascade coal field, up to 49 per cent, in one of the Saskatchewan lignites. The proportion of fixed carbon was from 42.9 per cent in the coal just mentioned to 78.6 in a washed coal from the Cascade coal field. The moisture content was naturally least (0.6 per cent) in one of the anthracitic coals and largest (29.7 per cent) in one of the lignites. It is probable that

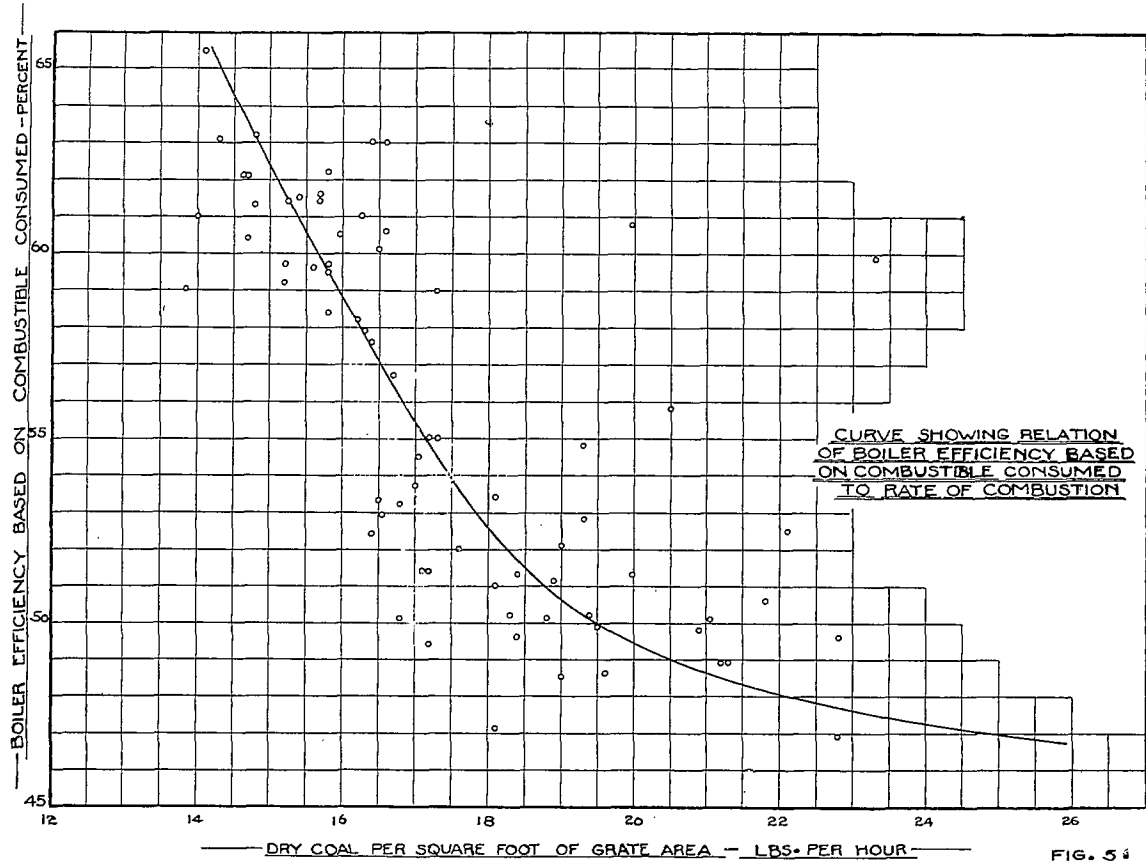

Fig. 35. Diagram showing boiler efficiency and rate of combustion.

the lignites when freshly mined contained even more moisture than is shown in Table IV, a certain amount having been inevitably lost in handling and transportation.

The calorific value will be seen to have had a fairly wide range, that of the dry coal varying from 10,690 to 14,490 B.T.U. per pound, while the calorific value of coal as fired varied from 7,520 to 14,010 B.T.U. per pound.

CONDITION OF COALS WHEN TESTED

The notes in Column 5, Table IV, give some information as to the treatment of the various coals at the colliery, but further details will be found in Part III, Vol. I, of this report. Their treatment after delivery at the University is described in detail in Part IV, Vol. I; but, speaking generally, it may be said that the coal as fired differed only from that delivered in that all lumps were broken to pass through a 3" ring. None of the smalls was removed from the coal, nor was it screened after passing through the crusher. For this reason comparatively small ($\frac{1}{4}$ ") openings between the grate bars were adopted, and, as mentioned elsewhere, in certain trials even this was found too large.

Certain coals (Nos. 23 and 23 SP) were sized at the colliery and were not crushed further after delivery. The briquettes also were fired in exactly the condition in which they were delivered. All of the washed coals when fired were of a fairly uniform, small size; the unwashed bituminous coals and lignites were practically run of mine but with no lumps larger than 3".

GENERAL RESULTS.

With regard to the general results of the boiler tests, it may be noted that the rate of working the boiler, as shown by the equivalent evaporation per square foot of heating surface per hour, was as uniform as could be reasonably expected in such a series of trials; this figure ranged between 2.90 and 3.52 pounds. The lower values of this quantity in general correspond to cases in which the fire was dirty or hard to work, the higher figures to cases where a freer combustion could be used with more satisfactory results. The pressure of draft and the rate of combustion were, of course, varied as little as possible throughout the series, but necessary changes were made for each trial with a view to securing the best possible gas analysis, and their amounts are indicated by the figures representing the weight of dry coal fired per square foot of grate per hour, the minimum for which is 13.8 pounds with a coal of excellent quality, while the maximum is 23.3 pounds in the case of one of the lignites.

The better coals naturally required the lower rates of combustion, and as a rule gave the higher boiler efficiencies. This is well shown by the curve plotted in Fig. 35 (Boiler efficiency based on combustible¹ plotted against dry coal per square foot of grate per hour). In this figure it will be seen that with the exception of four coals which gave apparently an extraordinarily

¹ *i.e.*, Efficiency of boiler only, excluding furnace.

high boiler efficiency, the values fall fairly well around the mean curve. The exceptions are, in fact, the points corresponding to the samples 40, 42, 43, and 44, lignites carrying much moisture, which age rapidly. It seems probable that some change in the quality of these coals, occurring during the time which unavoidably elapsed between the sampling, chemical analysis, and calorimeter determinations, and the boiler trials, affords an explanation of the apparently high boiler efficiencies obtained with them. The equivalent evaporation per pound of coal as fired does not appear to be abnormally high with these coals, which tends to confirm the above view.

It is well known that coals high in fixed carbon are, in general, utilized more efficiently in boiler work than is possible with coals high in volatile matter and low in fixed carbon. Fig. 36 illustrates this by showing the relation (for the particular boiler and rate of working employed in these trials) between the boiler efficiency based on combustible (and therefore excluding grate) and the fixed carbon content of the combustible portion of the fuel. Here, again, the fuels 40, 42, and 43 appear to give somewhat abnormal results, and the boiler efficiencies as plotted are probably higher than the true values for these coals.

The curves of Figs. 35 and 36 have been used in discussing the values of the various coals¹ and as a means of estimating the excellence or otherwise of the combustion in each case, their indications being considered together with those of columns 38 and 40, Table IV. (Flue gas per pound of coal and flue gas temperature) for this purpose.

A general comparison of all the coals is rendered easy by the two diagrams of Fig. 37, which are self explanatory. In studying these diagrams, it should be borne in mind that higher evaporative efficiencies could, of course, be obtained in a larger and more efficient boiler plant.²

RELATIVE MERIT OF THE COALS.

In working out the results of these trials several attempts have been made to determine an index number or figure for each coal, representing its steam-raising value as compared with that of some well known standard fuel. A great objection to the inclusion of such figures in the summary of results is, however, that they would necessarily be calculated without reference to the price of coal to the consumer, or the cost of its transportation, and would, therefore, be misleading to the layman although perhaps instructive to the engineer, who could apply the necessary corrections and modifications. Actually, of course, a coal (A) having an index number of say 40 might be a more economical fuel than one (B) whose number was 60, if the price of A as delivered was less than $\frac{2}{3}$ that of B. It was, therefore, felt that it would be better to let the figures of the boiler trials, as summarized in Table IV, speak for themselves, and only give such index numbers in discussing the various groups of coals.

¹See pp. 34 to 39.

²See also p. 11.

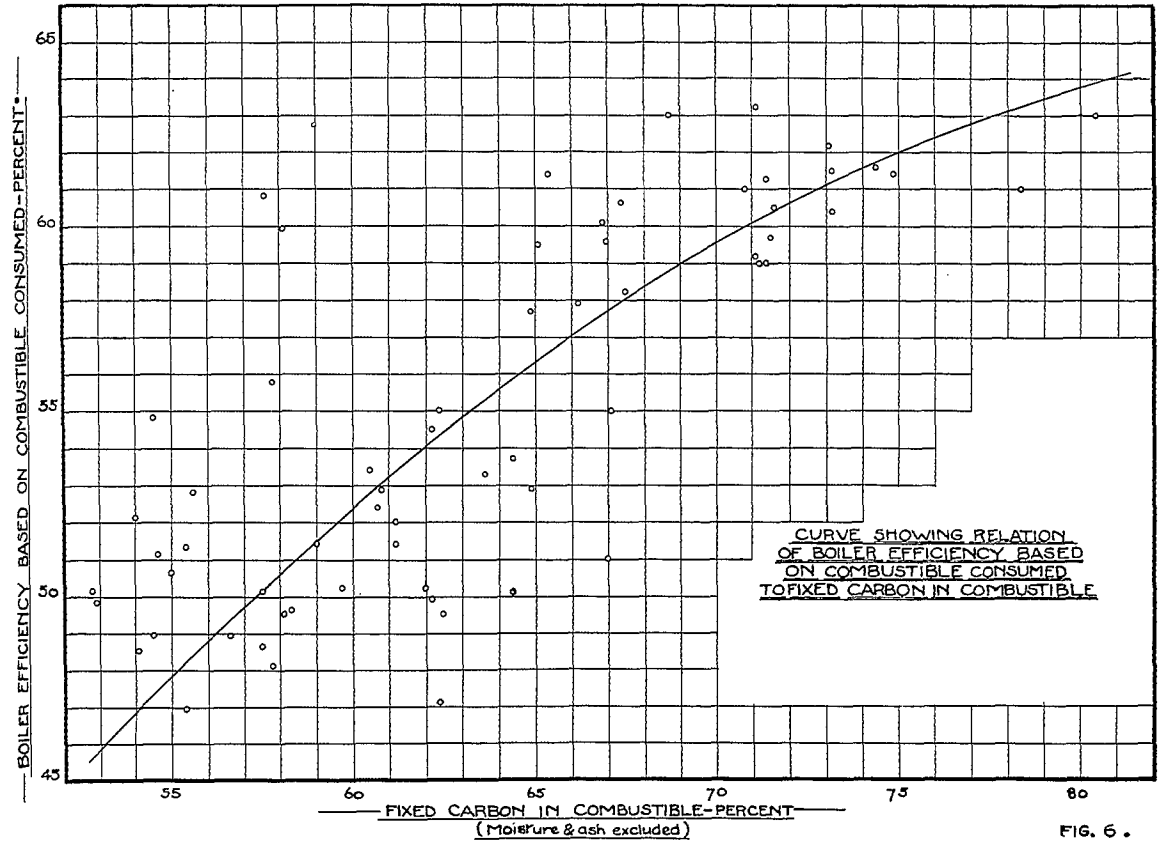
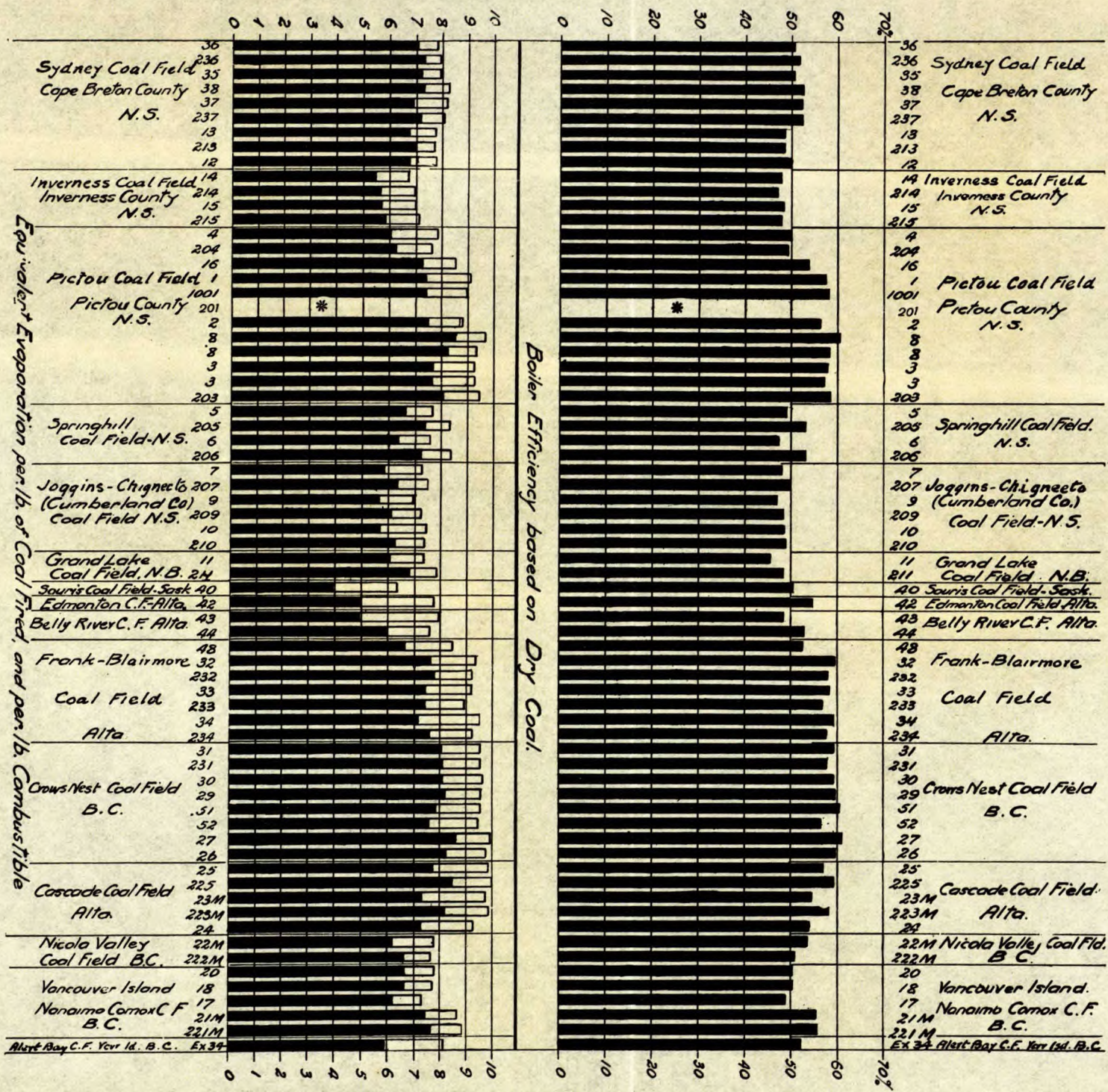

FIG. 6 .

Fig. 36. Diagram showing boiler efficiency and percentage of fixed carbon.

* Results of trial No. 18 rejected on account of error in sampling.

Fig. 37. Diagram showing boiler efficiency and equivalent evaporation.



The method of arriving at an index number which was finally adopted was worked out in the following way:—

The economic value of a steam coal, apart from its cost, was taken as depending on:—

(a) The amount of steam obtained from a given weight of the fuel as fired. This evidently takes account of the effect of the combustible properties of the coal on the boiler efficiency, and also allows for the amount and value of the combustible part of the coal, and for the heat losses due to the high temperature of the flue gases, or due to cleaning fires, removal of ash, and evaporation of moisture in coal. The expense of handling coal in the boiler room for a given production of steam will evidently be least where the evaporation per pound of coal is highest and is, therefore, also taken account of.

(b) The expense of labour for handling ash and refuse will be greatest in clinkering coals producing much refuse which will not pass through the grate. Two coals of equal evaporative power per pound may evidently be of unequal economic value from this cause. The total amount of incombustible matter having been taken account of under (a), a figure based on the ratio—

$$\frac{\text{weight of ash}}{\text{weight of ash and clinker}}$$

would give an idea of the non-clinkering quality of the fuel. The value of this factor, however, should obviously be small as compared with that of (a). Its numerical amount would be highest in a coal forming little or no clinker and in which all or nearly all the refuse could be removed by the use of a shaking grate.

In working out this idea, factor (a) received a value of 95 per cent and factor (b) 5 per cent, these figures indicating their relative importance, as gauged by the following considerations:—

If the cost of labour in hand fired boiler plants is taken at one-fifth the cost of the fuel itself, and if we assume that about one-fourth of the total labour cost is due to cleaning fires and handling ashes, it would appear that to the factor (b) should be assigned about one-twentieth of the weight given to factor (a), and this has accordingly been done. These figures are, however, somewhat arbitrary ones, and the resulting "index numbers" should be taken for what they are worth. Their chief use should be, to compare various coals of the same group, and in particular to illustrate the effect of washing coals more clearly than can be done by simply comparing the equivalent evaporation per pound of coal, washed and unwashed.

In selecting a standard fuel on which to base these index numbers, two kinds of coal naturally present themselves. The first is a Welsh coal of high quality, such as Nixon's Navigation, containing about 3 per cent of ash and having a calorific value of about 15,500 B.T.U. per pound of dry coal, which might be chosen, and given a rating of 100. A series of very careful boiler trials made in England with this coal¹ show a mean value of the ratio

¹ Donkin and Kennedy. Experiments on steam boilers—London, 1897. Office of "Engineering."

ash of about 0.65, and in boilers of about the same efficiency ash and clinker as the Babcock and Wilcox boiler used in the trials here reported, gave an equivalent evaporation (per pound of coal as fired) of about 10.0 pounds.

A high class Welsh coal, however, though widely known, is not easily available in Canada, and its qualities are not so familiar to Canadian power users as those of certain American coals, whose use has become standard in boiler trials in the United States. Such coals are Pocahontas and Georges Creek, from the Maryland and West Virginia coal fields. Trials have been made from time to time in the McGill University experimental boiler plant with the last named of these, and for comparison three additional tests were made on No. 2 Babcock and Wilcox boiler during the progress of the series here reported on, with Georges Creek coal purchased in Montreal. This coal, as placed on the Canadian market, appears to vary somewhat in quality, and the leading results of the three tests are as given below:—

TABLE V
Trials of Georges Creek Coal on No. 2 B. and W. Boiler.

Trial No.	Date	Caloric value per lb. as fired. B.T.U.	Coal as fired per sq. ft. grate per hr. lbs.	Equiv. evap. per lb. as fired. lbs.	Ash. lbs.	Clinker. lbs.	Refuse as weighed %	Moisture in coal as fired. %	Boiler efficiency (dry coal).
1	20/6/07	13810	14.25	8.53	85	136	9.3	1.9	59.6
68	21/9/09	13060	15.07	8.28	77	275	14.2	2.9	61.3
72	15/4/10	13510	14.45	8.91	104	177	11.8	2.0	63.6
Average				8.57	88	196			

This coal, as compared with Nixon's Navigation, would appear to have an index number of about 83.8, the method of calculation being as follows:—

Coal. Georges Creek as purchased in Montreal.

Trials Nos. 1, 68, and 72.

Average equivalent evaporation per pound of coal as fired, 8.57 lbs.

Average weight of ash, 88 lbs.

“ “ clinker, 196 lbs.

$$\text{Ratio} \frac{\text{ash}}{\text{ash} + \text{clinker}} = \frac{88}{284} = 0.31$$

For the Welsh coal, the figures are:—

(a) Average equivalent evaporation per pound of coal as fired 10.0 lbs. Value 95%

(b) Average ratio = $\frac{\text{ash}}{\text{ash} + \text{clinker}} = 0.65$ Value 5%

Hence for Georges Creek the index number as compared with the above would be:—

$$(a) 8.57 \times \frac{95}{10} = 8.57 \times 9.5 = 81.4$$

$$(b) 0.31 \times \frac{5}{0.65} = 0.31 \times 7.7 = 2.4$$

Total 83.8

and for any given coal, the figure as compared with Welsh would be (equivalent evaporation $\times 9.5$ + ash ratio $\times 7.7$) per cent or, if compared with Georges Creek, (equivalent evaporation $\times 11.3$ + ash ratio $\times 9.2$) per cent.

The effect of the term (b) is well shown on comparing, for instance, coals 42 and 43, in which we have

Coal No.	Trial No.	Equiv. Evap.	Ash lbs.	Clinker lbs.	Ash Ratio
42	65	4.98	265	115	0.70
43	64	4.91	119	556	0.18

As compared with the Welsh coal we should have the following rating:—

$$\text{No. 42—} 4.98 \times 9.5 + 0.70 \times 7.7 = 47.3 + 5.4 = 52.7\%$$

$$\text{No. 43—} 4.91 \times 9.5 + 0.18 \times 7.7 = 46.6 + 1.4 = 48.0\%$$

and, as compared with Georges Creek, the values would be:—

$$\text{No. 42—} 4.98 \times 11.3 + 0.70 \times 9.2 = 56.3 + 6.4 = 62.7\%$$

$$\text{No. 43—} 4.91 \times 11.3 + 0.18 \times 9.2 = 55.5 + 1.7 = 57.2\%$$

Nos. 42 and 43 are lignites carrying a high percentage of ash and refuse, but 42 proved considerably easier to work than 43, the benefit being obviously greater than would be shown by merely comparing the figures for equivalent evaporation.

The reader will find the index numbers for each group of coals in the remarks and tables following.

In selecting a coal for steam power purposes, the purchaser should be guided: (1) by the comparison of the costs of the various coals as delivered to his boiler room, (2) by the comparative evaporative efficiencies, and, (3) by the difficulties arising in working the fire and handling refuse as shown by trial logs and results. The cost of ash disposal is often an important factor; but in cases where refuse has not to be carted away, the amount of ash and refuse produced needs comparatively little consideration. Again, circumstances may be such that the emission of smoke cannot be permitted; in other cases, production of smoke causes no trouble. Such factors as these must be considered separately in each case.

The following is a list of the coals tested in order of evaporative efficiency, *i.e.*, equivalent evaporation from and at 212° per pound of coal as fired:—

TABLE VI
Coals in Order of Evaporation

(Equivalent evaporation per pound of coal as fired.)

Coal No.	LOCATION	Equiv. Evap.
27	No. 2 mine, Coal Creek, Fernie, B.C.	8.66
8 (Trial 11)	Main seam, Acadia colliery, Westville, N.S.	8.55
225	Washed, Old mine, Canmore, Alta.	8.44
26	No. 5 mine, Coal Creek, Fernie, B.C.	8.25
8 (Trial 32)	Main seam, Acadia colliery, Westville, N.S.	8.25
29	No. 9 mine, Michel, B.C.	8.24
223 M	Washed, Bankhead colliery, Bankhead, Alta.	8.20
231	Washed, No. 3 mine, Michel, B.C.	8.16
30	No. 7 mine, Michel, B.C.	8.11
31	No. 3 mine, Michel, B.C.	8.08
300	Washed, Main seam, Drummond colliery, Westville, N.S.	8.07
51	No. 2 seam, Hosmer, B.C.	7.84
232	Washed, Hillcrest colliery, Hillcrest, Alta.	7.77
25	Old mine, Canmore, Alta.	7.74
3 (Trial 3)	Main seam, Drummond colliery, Westville, N.S.	7.69
221 M	Washed, Comox colliery, Cumberland, B.C.	7.68
32	Hillcrest colliery, Hillcrest, Alta.	7.63
234	Washed, Denison colliery, Coleman, Alta.	7.60
52	No. 6 seam, Hosmer, B.C.	7.57
3 (Trial 7)	Main seam, Drummond colliery, Westville, N.S.	7.53
2	Cage Pit seam, Albion colliery, Stellarton, N.S.	7.49
21 M	Comox colliery, Cumberland, B.C.	7.41
33	No. 1 seam, Bellevue colliery, Lille, Alta.	7.41
233	Washed, No. 1 seam, Bellevue colliery, Lille, Alta.	7.40
38	Phalen seam, Glace Bay, N.S.	7.40
1	3rd seam, Albion colliery, Stellarton, N.S.	7.38
1001	Washed, No. 2 colliery, Springhill, N.S.	7.38
205	Washed, Hub seam, Glace Bay, N.S.	7.36
236	Washed, Hub seam, Glace Bay, N.S.	7.33
23 M	Bankhead colliery, Bankhead, Alta.	7.30
24.	(Briquettes), Bankhead, Alta.	7.27
16	Foord seam, Allan shaft, Stellarton, N.S.	7.24
35	Harbour seam, Glace Bay, N.S.	7.21
206	Washed, No. 3 colliery, Springhill, N.S.	7.20
237	Washed, Emery seam, Glace Bay, N.S.	7.17
34	Denison colliery, Coleman, Alta.	7.17
36	Hub seam, Glace Bay, N.S.	7.08
213	Washed, No. 1 colliery, Sydney Mines, N.S.	7.01
37	Emery seam, Glace Bay, N.S.	6.90
211	Washed, King's mine, Minto, N.B.	6.80
12	No. 2 colliery, Sydney Mines, N.S.	6.77
20.	Wellington seam, Cumberland, B.C.	6.76
13	No. 1 colliery, Sydney Mines, N.S.	6.74
5	No. 2 colliery, Springhill, N.S.	6.63
48	Leitch colliery, Passburg, Alta.	6.61
18	Upper seam, No. 1 mine, Nanaimo, B.C.	6.59
207	Washed, Chignecto colliery, Chignecto, N.S.	6.31
204	Washed, 6 ft. seam, Vale colliery, New Glasgow, N.S.	6.24
210	Washed, Joggins colliery, Joggins, N.S.	6.22
222 M	Washed, Middlesboro colliery, Coutlee, B.C.	6.22
6	No. 3 colliery, Springhill, N.S.	6.18

TABLE VI (Continued.)

Coal No.	LOCATION.	Equip. Evap.
17	Lower seam, No. 1 mine, Nanaimo, B.C.	6.17
22 M	Middlesboro colliery, Coutlee, B.C.	6.17
209	Washed, Minudie colliery, River Hebert, N.S.	6.09
4	6 ft. seam, Vale colliery, New Glasgow, N.S.	6.04
11	King's mine, Minto, N.B.	6.03
44	Galt colliery, Lethbridge, Alta.	5.92
Ex. 234	Pacific Coast Coal Co., Ltd., Vancouver island	5.92
215	Washed, Port Hood colliery, Port Hood, N.S.	5.85
7	Chignecto colliery, Chignecto, N.S.	5.82
214	Washed, Inverness colliery, Inverness, N.S.	5.67
15	Port Hood colliery, Port Hood, N.S.	5.67
10	Joggins colliery, Joggins, N.S.	5.66
9	Minudie colliery, River Hebert, N.S.	5.61
14	Inverness colliery, Chignecto, N.S.	5.46
42	Parkdale Coal Co., Edmonton, Alta.	4.98
43	Canada West Coal Co., Taber, Alta.	4.91
40	Western Dominion colliery, Taylorton, Sask.	3.91

TREATMENT AND BEHAVIOUR OF COAL IN FIRE

It is often the case that a coal of satisfactory calorific value and reasonably low in ash proves unsuitable as a boiler fuel on account of its behaviour in the fire, and such a coal by reason of the difficulty in working with it may be actually inferior as a practical fuel to another sample of lower evaporative efficiency. The trials here reported included almost every commercial variety of coal. Some were of excellent quality, and gave little trouble either as regards clinkering or smoke. Other samples were troublesome and dirty, requiring steam under the grate and a moderate forced draft to obtain the desired results.

Brief notes as to the treatment and behaviour of the coals will be found in one column in Table IV, and fuller information in the detailed logs of each trial published in Vol. IV, of this report.

For convenience in comparing the coals of each of the principal groups, tables¹ and notes are given below under the various geographical headings embodying the observations made during the trials as to smoke production, trouble from clinker, coking qualities of coal, and possibility of using a shaking grate. These, with information as to the frequency of slicing and cleaning the fire, will enable a judgment to be formed as to the quality of the coals from the fireman's point of view. It should be noted that in order to carry out the trials, it was necessary to clean the fire in every case just before the close of the test; this has, of course, been included in stating the number of times the fire was cleaned.

¹ Tables VII, X, XV, XVII, XIX, XXI, XXIV, and remarks in text.

REMARKS ON COALS AS ARRANGED GEOGRAPHICALLY BY COAL FIELDS

SYDNEY COALFIELD, CAPE BRETON COUNTY, N. S.

Coals from mines of Dominion Coal Co., and Nova Scotia Steel & Coal Co. (Nine boiler trials, six on unwashed samples.)

These are all bituminous coals, giving a long flame and considerable smoke. The equivalent evaporation per pound of dry coal ranged from 6.91 to 7.68, and the steam raising value of the coals, as compared with Welsh of high quality, is estimated at from 67 per cent to 74 per cent, or from 79 per cent to 87 per cent as compared with Georges Creek. The average for the six unwashed coals is 83.2 per cent. Washing improved the evaporation from 5 to 6 per cent. Most of the samples were good steam coals, although several gave trouble from clinker, the worst being those from No. 1 colliery, N. S. S. & C. Co., and the Hub seam, D. C. Co. The first named needed a slight air pressure under the bars; all the rest were burnt with natural draft. The clinker from the Hub Seam coal was found to attack the fire bars. Coals from the Hub and Phalen seams, D. C. Co., appeared to give the best all round results.

TABLE VII.

Remarks on Combustion of Sydney Coals

Coal No.	36	236	35	38	37	237	13	213	12
Draft, natural or forced	N	N	N	N	N	N	N and F	N	N
Smoke	Much	Much	Much	Much	Dense	Much	Much	Much	Much
Flame	Much	Much	Long	Much	Much	Much	Much	Much	Long
Fire sliced . . .	3 times	twice	3 times	3 times	4 times	twice	once	once
Fire cleaned . .	once	once	once	once	twice	once	twice	once	twice
Clinker	easy	hard attacks bars	some trouble	hard	easy	troublesome	some difficulty	easy	some difficulty
Steam under bars	no	yes	advisable	advisable	no	no	yes	yes	no
Does coal cake?	no	good deal	no	slightly	slightly	very little	yes	yes	yes
Could shaking grate be used	no	no	no	no	yes	no	no	no

TABLE VIII.
Evaporation with Sydney Coals.

Coal No.	Description	Cal. value per lb. as fired	Moisture in coal as fired %	Ash and clinker from dry coal %	Index No.	Equiv. evap. per lb. as fired
36	Hub seam, D.C. Co.	13490	2.7	5.64	82.9	7.08
236	" " washed	13670	4.5	3.77	88.3	7.33
35	Harbour seam, D. C. Co.	13750	1.8	6.58	85.2	7.21
38	Phalen seam, D. C. Co.	13620	2.8	5.2	86.7	7.40
37	Emery seam, D. C. Co.	12750	2.8	9.8	80.6	6.90
237	" " washed	13260	4.5	5.95	85.0	7.17
13	No. 1 colliery, N.S.S. & C. Co.	13450	2.3	5.9	79.8	6.74
213	" " washed	14010	3.3	5.0	86.2	7.01
12	No. 2 colliery, N.S.S. & C. Co.	13110	4.2	7.1	79.4	6.77

INVERNESS COAL FIELD, INVERNESS COUNTY, N.S.

Coals from mines of Inverness Ry. & Coal Co. and Richmond Ry. Coal Co., Nova Scotia. (Four boiler trials, two on unwashed samples).

The two coals tested (each washed and unwashed) are bituminous coals somewhat high in ash, and gave an equivalent evaporation per pound of dry coal of from 5.86 to 6.24. The steam raising value of the unwashed coals, as compared with Georges Creek, would be from 66 per cent to 67 per cent. Washing increased the evaporation considerably and improved the index number to 70.0 per cent. Boiler efficiencies with these coals were somewhat low. Natural draft was used, with steam under the grate. The Port Hood coal seems the better of the two.

The unwashed coals were somewhat dirty in the fire, which was cleaned twice in each trial, and the use of the slice was also necessary. Shaking grates could not have been used. All four samples produced a fair amount of smoke. Clinker was adherent in the unwashed coals, but gave much less trouble in the washed samples.

TABLE IX.
Evaporation with Inverness Coals

Coal No.	Description	Cal. value per lb. as fired	Moisture in coal as fired %	Ash and clinker from dry coal %	Index No.	Equiv. evap. per lb. as fired
14	Inverness coll., I. R. & C. Co.	11260	7.3	8.6	65.7	5.46
214	" " washed	11620	9.2	6.0	70.2	5.67
15	Port Hood coll., R.R.C. Co. . .	11380	3.3	12.2	66.8	5.67
215	" " washed	11860	5.5	9.7	70.2	5.85

PICTOU COAL FIELD, PICTOU COUNTY, N. S.

Coals from mines of Acadia Coal Co., Ltd., and Intercolonial Coal Mining Co., Nova Scotia. (Twelve boiler trials, of which nine were on unwashed, and three on washed samples).

These are bituminous coals giving a long flame, and are slightly higher in ash and lower in volatile matter than the Sydney coals; the equivalent evaporation per pound of dry coal ranged from 6.23 to 8.69; most of the samples are good and some were found to be excellent steam coals. The best unwashed samples were worth from 96 to 99 per cent, the remainder from 70 to 89 per cent as compared with Georges Creek. All were burnt with natural draft, and no serious difficulty with clinker was experienced, although a considerable amount was formed in most cases. The beneficial effect of washing on these coals was not very marked. Fairly high boiler efficiencies were obtained. Coal No. 8 from the Main seam, Acadia colliery, gave on the whole the most satisfactory results. The samples of three of these coals were large enough to allow of two trials—coals Nos. 1, 3, and 8.

TABLE X.
Remarks on Combustion of Pictou County Coals

Coal No.	4	204	16	1	1001
Draft, natural or forced	N	N	N	N	N
Smoke				much	much
Flame		much	much	much	much
Fire sliced				3 times	once
Fire cleaned	twice	twice	twice	once	twice
Clinker	not much trouble	some trouble	trouble- some	easy	easy
Steam under bars	no	no	no	no	no
Does coal cake?		no	yes	yes	yes
Could shaking grate be used?				yes	yes

TABLE X.—(Continued)

Coal No.	2	8 (Trial 11)	8 (Trial 32)	3 (Trial 3)	3 (Trial 7)	203
Draft, natural or forced	N	N	N	N	N	N
Smoke			light			
Flame	much	much	much			
Fire sliced				7 times	3 times	3 times
Fire cleaned	twice	once		twice	3 times	once
Clinker	easy	some trouble	easy	some trouble	little trouble	easy
Steam under bars			no			
Does coal cake?	no		no			yes
Could shaking grate be used?			yes			

NOTE.—A boiler trial (No. 18) was made with No. 1 coal after washing, but, on account of an error in sampling, the test had to be rejected, and is, therefore, not published.

TABLE XI
Evaporation with Pictou County Coals

Coal No.	Description	Cal. value per lb. as fired	Moisture in coal as fired %	Ash and clinker from dry coal %	Index No.	Equiv. evap. per lb. as fired
4	Vale colliery, A. C. Co.	11680	2.8	14.3	69.6	6.04
204	" " " washed	12260	3.9	10.3	72.5	6.24
16	Allan Shaft colliery, A.C. Co. .	12990	1.8	9.9	84.5	7.24
1	3rd seam, Albion colliery, A. C. Co.	12330	2.0	10.8	85.9	7.38
1001	" " " "	12210	2.0	12.7	86.2	7.38
2	Cage Pit seam, Albion colliery, A. C. Co.	12880	2.3	11.6	87.2	7.49
8	Main seam, Acadia colliery, A.C. Co.	13640	1.6	8.2	98.8	8.55
8	Main seam, Acadia colliery, A.C. Co.	13660	1.5	8.37	95.8	8.25
3	Drummond colliery, I.C.M. Co.	12820	1.1	12.4	89.2	7.69
3	" " " "	12810	1.2	12.6	87.6	7.53
203	" " " " washed	13320	1.7	9.03	94.3	8.07

SPRINGHILL COAL FIELD, CUMBERLAND COUNTY, N.S.

From mines of Cumberland Railway & Coal Co., Ltd., Nova Scotia. (Four boiler trials, two on unwashed and two on washed samples.)

These are bituminous coals of moderately good steaming quality, not very high in ash and giving considerable smoke. Both were burnt under natural draft, giving an equivalent evaporation per pound of dry coal of from 6.13 to 7.63. Clinker was viscous in all four trials. The No. 2 Colliery coal gave the best evaporation, while that from No. 3 gave least trouble in working the fire. As compared with Georges Creek, these coals appear to have a value of 71 per cent to 77 per cent, which is increased very considerably on washing.

TABLE XII
Evaporation with Springhill Coals

Coal No.	Description	Cal. value per lb. as fired	Moisture in coal as fired %	Ash and clinker from dry coal %	Index No.	Equiv. evap. per lb. as fired
5	No. 2 colliery, C. R. & C. Co.	13120	1.9	7.9	76.7	6.63
205	" " " washed	13330	3.8	5.6	86.0	7.36
6	No. 3 colliery, C. R. & C. Co.	12710	2.2	8.8	71.4	6.18
206	" " " washed	13110	3.4	8.1	85.3	7.20

JOGGINS-CHIGNECTO COAL FIELD, CUMBERLAND COUNTY, N.S.

From mines of Maritime Coal, Ry. & Power Co., Minudie Coal Co., Ltd., and Canada Coal & Ry. Co., Ltd., Nova Scotia. (Six boiler trials, three on unwashed and three on washed samples.)

These are bituminous coals of moderate steaming quality, fairly high in ash, and giving some trouble in working the fire, but are better boiler fuels after washing. Steam under the bars was found necessary, except for No. 210, and forced draft was needed in three of the tests. The equivalent evaporation per pound of dry coal in this group was from 5.78 to 6.67. The washed coal from the Joggins mine gave the least trouble from clinker, although the Chignecto coal gave the best evaporation and boiler efficiency. These coals in the unwashed state appear to have from 65 per cent to 70 per cent of the steaming value of Georges Creek coal.

TABLE XIII
Evaporation with Joggins-Chignecto Coals

Coal No.	Description	Cal. value per lb. as fired	Moisture in coal as fired %	Ash and clinker from dry coal %	Index No.	Equiv. evap. per lb. as fired
7	Chignecto colliery, M.C.R. & P. Co.	11790.	3.0	11.2	70.4	5.82
207	Chignecto colliery, M.C.R. & P. Co.	12210	5.3	7.3	75.9	6.31
9	Minudie colliery, M. C. Co. . .	11500	2.8	12.2	65.4	5.61
209	" " " " "					
	washed	12160	3.5	12.7	71.4	6.09
10	Joggins colliery, C. C. & R. Co.	11250	2.9	14.8	66.2	5.66
210	" " " "					
	washed	12250	3.8	8.2	73.7	6.22

GRAND LAKE COAL FIELD.

Coal from King's mine, Minto, N.B. (Two Boiler Trials.)

A bituminous coal carrying a fair amount of ash and of moderate steaming quality. Considerably improved by washing. The unwashed coal required forced draft, and steam under the bars; fire had to be cleaned three times, and clinker was rather troublesome. Boiler efficiency was rather low.

TABLE XIV
Evaporation with Grand Lake Coal

Coal No.	Description	Cal. value per lb. as fired	Moisture in coal as fired %	Ash and clinker from dry coal %	Index No.	Equiv. evap. per lb. as fired
11	King's mine, Minto, N.B. . . .	12800	0.7	11.3	70.6	6.03
211	" " " " " washed	13590	1.7	9.4	79.3	6.80

SOURIS, EDMONTON, AND BELLY RIVER COAL FIELDS.

Lignites and Lignitic Coals from Saskatchewan and Alberta.

Mined by the Western Dominion Collieries Ltd., Taylorton, Sask., Parkdale Coal Co., Edmonton, Alta., Canada West Coal Co., Taber, Alta., and the Alberta Ry. & Irrigation Co., Ltd., Lethbridge, Alta. (Four boiler trials, all on unwashed samples.)

These very interesting fuels, of low calorific value, are moderately high in ash, and contain much moisture. They weather rapidly on exposure to air, and as some time necessarily elapsed after receipt before they could be tested, the results of the trials can not apply with exactness to freshly mined coal. The tests with No. 44 and No. 40 were unavoidably short, owing to the small amount of fuel available. The unexpectedly high boiler efficiencies apparently obtained may be due to the fact that the real calorific values of the coals when used differed from those found by the chemists at an earlier date. The following table gives an idea of the working qualities of these fuels:—

TABLE XV

Remarks on Combustion of Lignites and Lignitic Coals

Coal No.	40	42	43	44
Draft, natural or forced.	F	N	N and F	F
Smoke.	very little	none	light	none
Flame.	long	long
Fire sliced.	4 times	4 times	once	twice
Clinker.	easy	bad	moderate	bad without steam
Fire cleaned	once	twice	twice	once
Steam under bars	no	yes	yes	yes
Does coal cake?	no	no	no	no
Could shaking grate be used? . . .	yes	yes, with steam	yes, with steam	no

The steaming value of these fuels is estimated at from 48 per cent to 68 per cent of that of Georges Creek coal. Owing to the amount of moisture inseparable from these coals, the evaporation per pound of dry coal is not a satisfactory criterion.

TABLE XVI

Evaporation with Lignites and Lignitic Coals

Coal No.	Description	Cal. value per lb. as fired	Moisture in coal as fired %	Ash and clinker from dry coal %	Index No.	Equiv. evap. per lb. as fired
40	Western Dom. Colliery Co., Taylorton, Sask.	7520	29.7	8.24	48.1	3.91
42	Parkdale Coal Co., Edmonton, Alta.	8760	19.7	11.4	62.7	4.98
43	Canada West Coal Co., Taber, Alta.	9790	11.3	17.3	57.2	4.91
44	Galt colliery, Lethbridge, Alta.	10740	8.3	10.4	68.7	5.92

FRANK-BLAIRMORE COAL FIELD, ALBERTA.

Coals mined by Leitch Collieries Ltd., Hillcrest Coal and Coke Co., Ltd., West Canadian Collieries Co., and International Coal and Coke Co., Ltd. (Seven boiler trials, four on unwashed and three on washed samples.)

These are bituminous coals not very high in volatile matter, but carrying a considerable amount of ash. They are nevertheless good steam coals, giving little trouble in working the fire. They gave good boiler efficiencies, and the equivalent evaporation per pound of dry coal ranged from 6.67 to 7.69 for the unwashed samples.

The following table gives the working qualities of the coals from the Frank-Blairmore coal field:—

TABLE XVII

Remarks on Combustion of Frank-Blairmore Coals

Coal No.....	48	32	232
Draft, natural or forced.....	F and N	N	N
Smoke	moderate	rather heavy	not much
Flame.....	moderate	moderate	moderate
Fire sliced.....		raked	
Fire cleaned.....	twice	twice	twice
Clinker.....		little trouble	little trouble
Steam under bars.....	no	no	no
Does coal cake?.....	considerably	yes	slightly
Could shaking grate be used?.....	yes	yes	yes

TABLE XVII—(Continued)

Coal No.	33	233	34	234
Draft, natural or forced.....	F	F	F	F
Smoke.....	dense	fairly dense	fairly dense	fairly dense
Flame.....	moderate	moderate	moderate	moderate
Fire sliced.....		raked	raked	
Fire cleaned.....	twice	once	twice	twice
Clinker.....	little trouble	hardly any	easy	not much trouble
Steam under bars.....	—	—	—	—
Does coal cake?.....	somewhat	somewhat	yes	slightly
Could shaking grate be used?...	yes	yes	yes	yes

Washing appears of somewhat doubtful value if these coals are intended for steam purposes. The index numbers indicate that the unwashed coals have from 76 per cent to 89 per cent of the value of Georges Creek. No. 48 is the least satisfactory coal but is not so smoky as the others.

TABLE XVIII

Evaporation with Frank-Blairmore Coals

Coal No.	Description	Cal. value per lb. as fired	Moisture in coal as fired %	Ash and clinker from dry coal %	Index No.	Equiv. evap. per lb. as fired
48	Leitch colliery, Passburg, Alta.	12130	0.9	17.0	76.4	6.61
32	Hillcrest colliery, Hillcrest, Alta.	12360	0.8	15.5	89.3	7.63
232	Hillcrest colliery, Hillcrest, Alta., washed.	12900	3.8	9.5	91.3	7.77
33	Bellevue colliery, Bellevue, Alta.	12280	0.8	14.1	85.8	7.41
233	Bellevue colliery, Bellevue, Alta., washed.	12510	3.6	10.5	86.4	7.40
34	No. 2 seam, Denison colliery, Coleman, Alta.	11630	0.8	18.8	83.3	7.17
234	No. 2 seam, Denison colliery, Coleman, Alta., washed.	12690	3.7	10.6	89.8	7.60

CROWSNEST COAL FIELD

Coals mined by Crowsnest Pass Coal Co., Ltd., and Hosmer Mines Ltd., British Columbia. (Eight boiler trials, one only on a washed coal.)

These bituminous coals are somewhat low in volatile matter (21 per cent to 26 per cent) and carry a moderate amount of ash. They rank among the best Canadian steam coals and gave equivalent evaporations per pound of dry coal ranging from 7.68 to 8.75. As compared with Georges Creek their steaming values are estimated at 88 per cent to 101 per cent. Nearly all were burnt with natural draft and gave only a moderate amount of smoke. The most satisfactory all round were perhaps Nos. 26, 29, and 30, although 27 gave the highest evaporation.

TABLE XIX

Remarks on Combustion of Crowsnest Coals

Coal No.	31	231	30	29
Draft, natural or forced.	N	N	N	N
Smoke.	light	moderate	light	moderate
Flame.	a good deal	considerable
Fire sliced.	3 times
Fire cleaned.	once	twice	twice	twice
Clinker.	some trouble	hard	easy to handle	easy to handle
Steam under bars.	at times	no	no	no
Does coal cake?	no	yes	very little	very slightly
Could shaking grate be used?	yes, with steam	no	yes	yes

TABLE XIX.—(Continued)

Coal No.	51	52	27	26
Draft, natural or forced	N and F	N and F	N	N
Smoke	fair amount	good deal	moderate	little
Flame	fair amount	moderate
Fire sliced	sliced twice and raked	raked
Fire cleaned	once	twice	once	twice
Clinker	very little trouble	some trouble	some trouble	very little trouble
Steam under bars	no	no	yes	no
Does coal cake?	slightly	yes	a little	yes
Could shaking grate be used? . . .	yes	possibly	possibly	yes

TABLE XX

Evaporation with Crowsnest Coals

Coal No.	Description	Cal. value per lb. as fired	Moisture in coal as fired %	Ash and clinker from dry coal %	Index No.	Equiv. evap. per lb. as fired
31	No. 3 mine, Michel colliery, C.N.P.C. Co.	13180	0.7	11.4	93.6	8.08
231	No. 3 mine, Michel colliery, C.N.P.C. Co., washed . . .	13610	4.9	7.4	97.1	8.16
30	No. 7 mine, Michel colliery, C.N.P.C. Co.	13230	1.0	12.7	94.4	8.11
29	No. 8 mine, Michel colliery, C.N.P.C. Co.	13350	1.0	10.0	96.6	8.24
51	No. 2 seam, Hosmer mines . .	12570	1.1	15.3	90.2	7.84
52	No. 6 seam, " "	12890	1.5	16.2	87.8	7.57
27	No. 2 mine, Coal Creek, Fernie, B.C., C.N.P.C. Co.	13680	1.0	9.6	101.3	8.66
26	No. 5 mine, Coal Creek, Fernie, B.C., C.N.P.C. Co.	13350	1.0	10.8	95.7	8.25

CASCADE COAL FIELD.

Coals mined by H. W. McNeil Co., Canmore, Alta., and Bankhead Mines Ltd., Bankhead, Alta. (Five boiler trials, two on washed samples.)

These are anthracite coals containing 12 per cent to 17 per cent of volatile matter and (in the unwashed state) are rather high in ash. No. 24 was a sample of briquettes made (with tar) from Bankhead anthracite dust. The briquettes did not seem much (if at all) superior in evaporative efficiency to the plain coal. All the samples proved good steam coals with forced draft, and the unwashed samples gave equivalent evaporations per pound of dry coal of 7.37 and 7.80. Boiler efficiencies were good, and the beneficial effect of washing was very marked.

TABLE XXI

Remarks on Combustion of Cascade Coals

Coal No.	25	225	23 M	223 M	24 (briquette)
Draft, natural or forced.	F	F	F	F	F
Smoke.	none	none	none	practically none	very little
Flame	none	none	none	none	none
Fire sliced	3 times	3 times	twice	3 times
Fire cleaned	twice	once	twice	once	once
Clinker	little trouble	not much trouble	very little and soft	very soft	soft lumps
Steam under bars	yes	yes	none	none	none
Does coal cake?	no	no	no	no	no
Could shaking grate be used? .	yes, with steam	yes, with steam	yes	yes	yes

No. 25 seems the better steam coal of the two, and would be worth about 91 per cent as compared with Georges Creek. No. 23 was easier to work in the fire.

TABLE XXII

Evaporation with Cascade Coals

Coal No.	Description	Cal. value per lb. as fired	Moisture in coal as fired %	Ash and clinker from dry coal %	Index No.	Equip. evap. per lb. as fired
25	No. 1 mine, Canmore, Alta., H. W. McNeil Co.	13100	0.8	15.6	90.6	7.74
225	No. 1 mine, Canmore, Alta., H. W. McNeil, washed . . .	13780	4.3	8.9	98.5	8.44
23 M	Mixed coal, Bankhead colliery, Bankhead, Alta., B.M. Ltd..	13000	0.6	15.6	84.4	7.30
223 M	Mixed coal, Bankhead colliery, Bankhead, Alta., B.M. Ltd. washed	13590	2.7	9.5	94.4	8.20
24	Briquettes from Bankhead colliery	13010	0.7	15.2	84.5	7.27

NICOLA VALLEY COAL FIELD, B.C.

Coal mined by the Nicola Valley Coal and Coke Co. (Two boiler trials, one on unwashed and one on washed coal).

The coal tried was a mixture from the Jewel seam, No. 1 mine, and the Rat Hole seam, No. 2 mine, Middlesboro colliery, Coutlee, B.C. It is a bituminous coal high in volatile matter and containing a fair amount of ash. It was burnt under natural draft, and gave a short flame and considerable smoke. It does not cake and could be worked on a shaking grate.

TABLE XXIII

Evaporation with Nicola Valley Coal

Coal No.	Description	Cal. value per lb. as fired	Moisture in coal as fired %	Ash and clinker from dry coal %	Index No.	Equiv. evap. per lb. as fired
22 M	Mines 1 and 2, Middlesboro colliery, N.V.C. & C. Co.	11160	4.8	14.0	72.1	6.17
222 M	Mines 1 and 2, Middlesboro colliery, N.V.C. & C. Co., washed	11840	6.2	10.4	72.7	6.22

NANAIMO-COMOX AND ALERT BAY COAL FIELDS.

Coals mined by the Wellington Colliery Co., Ltd., at Extension and Cumberland, B.C., by the Pacific Coast Coal Co., Ltd., Alert bay, B.C., and by the Western Fuel Co., Ltd., Nanaimo, B.C. (Six boiler trials, only one on a washed sample.)

These are bituminous coals ranging from 10 per cent to 15 per cent in ash, and most are high in volatile matter. The Nanaimo-Comox coals are fairly good steam coals and may be classed as having from 72 per cent to 86 per cent of the steaming value of Georges Creek. It was found impossible to avoid making considerable smoke. The Comox coal (No. 21 M) gave the most satisfactory results in this group.

TABLE XXIV

Remarks on Combustion of Vancouver Island Coals

Coal No.	20	18	17	21 M	221 M	Ex. 34
Draft, natural or forced ...	N	N	N and F	N	N	N and F
Smoke	dense	medium	heavy	a large amount	medium	black
Flame.	considerable	considerable	much	medium	medium	large amount
Fire sliced.	4 times	5 times	raked	once and raked
Fire cleaned	once	twice	twice	twice	twice	twice
Clinker	a good deal	troublesome	a good deal	much trouble	troublesome	some trouble
Steam under bars.	no	yes	yes	no	yes	yes
Does coal cake?	no	no	slightly	slightly	yes	no
Could shaking grate be used? ..	possibly	no	possibly with steam	yes	possibly with steam	no

TABLE XXV

Evaporation with Vancouver Island Coals

Coal No.	Description	Cal. value per lb. as fired	Moisture in coal as fired %	Ash and clinker from dry coal %	Index No.	Equiv. evap. per lb. as fired
20	Wellington seam, Wellington Extension colliery, W.C. Co., Ltd., Extension, B.C.	12980	1.4	6.3	79.4	6.76
18	Upper seam, No. 1 mine, W.F. Co., Ltd., Nanaimo, B.C.	12540	2.3	8.7	77.5	6.59
17	Lower seam, do.	12210	2.1	11.4	72.2	6.17
21 M	Nos. 4 and 7 mines, Comox colliery, W.C. Co., Ltd., Cumberland, B.C.	12880	1.0	10.8	86.5	7.41
221 M	Do, washed	13180	3.0	9.86	91.2	7.68
Ex. 34	Suquash mine, Alert bay, P.C.C. Co.	10950	5.3	15.86	68.4	5.92

It should be noted that the Alert Bay coal (Ex. 34) does not really belong to the same group as the rest.

THE
COALS OF CANADA:
AN ECONOMIC INVESTIGATION
VOL. II

PART VIII
GAS PRODUCER TESTS
BY
R. J. DURLEY

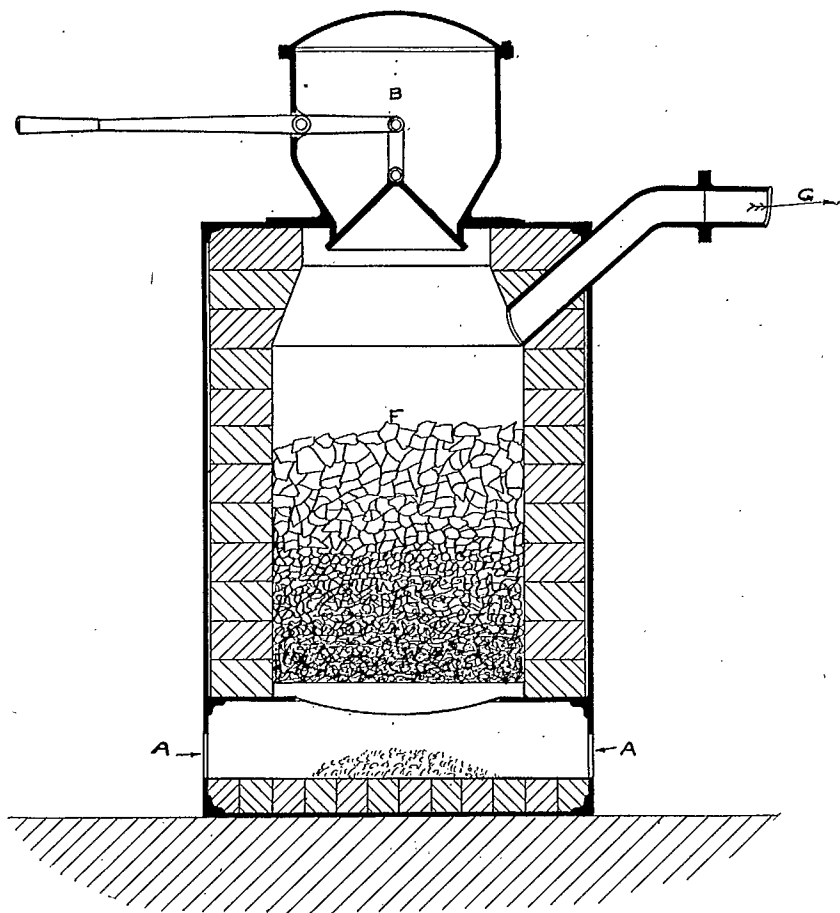

Fig. 38. Diagram of simple form of gas producer.

PART VIII

GAS PRODUCER TESTS

R. J. DURLEY

GAS PRODUCERS AND THEIR METHOD OF WORKING.

As an introduction to the discussion of the trials of Canadian coals made in the experimental producer plant at McGill University, an elementary account of the theory and action of the gas producer will be found useful. Gas producers differ in design according to the fuel with which they are to be operated and the purpose for which the gas is to be employed. Gas for power purposes, to be used successfully in an internal combustion engine, must be cleaner and more uniform in composition than is necessary in the case of gas to be used only for fuel or metallurgical work. The preparation of "coal gas" by distilling highly bituminous coal in air tight retorts is, of course, the usual process for making gas for city supply, and this gas, when properly cleaned, can be used for power purposes. Such gas must be clearly distinguished from that known as "producer gas," and is usually too expensive for use either in gas engines for power purposes or for metallurgical work. On the other hand, certain kinds of producer gas are largely used for city supply when specially treated to render them suitable for this purpose.

The term "producer gas" is used to denote the mixture of gases obtained by passing air, or a mixture of steam and air, through a body of incandescent solid carbonaceous fuel: coal, coke, peat, or wood are all successfully used. A blast furnace producing pig iron is, in fact, an example of such a producer on a large scale, and blast furnace gases can be used either for firing boilers or (after proper cleaning) for supplying gas engines for power purposes.¹ In a blast furnace air alone is passed through the heated coke which forms so large a part of the charge of the furnace.

The simplest kind of gas producer is one using a fuel (such as coke) containing little or no volatile combustible matter and supplied only with air. The arrangement of a simple updraft producer is shown in Fig. 38, and it will be seen to contain a somewhat deep bed of fuel, **F**, surrounded by a gas tight envelope of plate iron, with proper provision for the supply of air at **A**, the introduction of fuel at **B**, and the removal of the resulting gases at **C**.

The general nature of the actions occurring in such a producer can be readily followed by any one having a slight knowledge of chemistry. With a sufficiently deep bed of fuel and a properly adjusted air supply, it will be found that the carbon of the fuel unites with the oxygen of the air to form carbon monoxide (CO), a combustible but poisonous gas, which, if supplied with a further amount of air at a proper temperature, will unite with more oxygen and form carbon dioxide (CO₂), the product of complete combustion of carbon

¹ See, for example, Trans. A.S.M.E., June, 1910, for an account of a very large blast furnace gas engine power plant.

and oxygen. The formation of carbon monoxide in the gas producer thus involves partial combustion of the carbon, and is accompanied by the evolution of only about 30 per cent of the heat which could be produced by burning the same weight of carbon completely to carbon dioxide. This 30 per cent is lost, being dissipated by radiation and carried off as sensible heat in the hot producer gas; the balance (about 70 per cent) can be utilized by burning the producer gas with more air. The efficiency of a producer, such as that just described, can, therefore, not exceed about 70 per cent, since a producer of 100 per cent efficiency is one giving gas which, if burnt, would develop 100 per cent of the calorific value of the fuel employed.¹ The *efficiency of a producer is*, in fact, the ratio
$$\frac{\text{Calorific value of gas produced}}{\text{Calorific value of fuel consumed}}$$

It has been found experimentally that the heat produced by burning one pound of carbon to carbon monoxide (CO) amounts to about 4,200 B. T. U.,² while if the resulting $2\frac{1}{2}$ pounds of carbon monoxide are permitted to unite with a further supply of oxygen so as to produce $3\frac{3}{4}$ pounds of carbon dioxide, an additional 10,450 B.T.U. is generated. The calorific value of one pound of carbon is, therefore, 14,650 B.T.U. when it is completely burnt to carbon dioxide. Hence, as has just been explained, the heat efficiency of the process of formation of carbon monoxide will be $\frac{10450}{14650}$ or 71.3 per cent under ideal or theoretically perfect conditions. In an actual producer of the kind described above even this figure cannot be reached, and it is necessary to adopt some means for utilizing a portion of the heat which would otherwise be wasted. This can be done most simply by mixing a proper amount of steam with the air supply.

If steam be passed over incandescent carbon, a chemical reaction occurs which splits up the steam into its constituents, hydrogen and oxygen, and the oxygen, under suitable conditions of temperature, unites with the carbon, usually forming both carbon monoxide and carbon dioxide. The gas resulting from this process will, therefore, under ideal conditions, be a mixture of hydrogen, carbon monoxide, and carbon dioxide (the latter in small amount if conditions are favourable). The dissociation of the elements of the steam, however, requires more heat than can be furnished by the combustion of carbon with the resulting oxygen; hence, on the whole, the formation of "water gas," by passing steam over red hot carbon, is characterized by the lowering of the producer temperature because of the heat absorbed, and, if heat is not supplied from an external source or from some other chemical reaction, the temperature will soon fall so low that the decomposition of the steam ceases. This necessary supply of heat could evidently be furnished by carrying on the formation of "air gas" in proper quantity, as explained in the preceding paragraph, and in many actual gas producers the two processes are in fact carried on simultaneously, the supply of steam being so

^{1, 2} For notes as to the meaning of terms such as "Calorific Value," "British Thermal Unit," etc., and as to methods and units of heat measurement, see Parts VII and IX, of this volume.

proportioned to that of oxygen that the heat resulting from the formation of "air gas" by burning a portion of the carbon to carbon monoxide by means of the oxygen of the air, is used up in maintaining the "water gas" reaction by decomposing the steam. The resulting gas, is, therefore, composed of hydrogen, carbon monoxide, and a proportion of carbon dioxide, the whole diluted by nitrogen and other inert gases derived from the air supply.

It should be stated that in the formation of "air gas" a proportion of carbon dioxide is always formed, in addition to the carbon monoxide, its amount depending upon various circumstances, one of which is the temperature of the producer. Further, should the fuel used be one which (like anthracite or coke) contains any compounds of hydrogen and carbon, the resulting gas will probably contain a proportion of volatile or gaseous hydrocarbon compounds. The following table gives analyses showing (a) the composition of a sample of gas furnished by a producer using anthracite coal and supplied with both air and steam, which may be taken as typical of ordinary "producer gas" as used for gas engine work; (b) the composition of typical "air gas" in which the supply was air containing only a very small proportion of water vapour and the fuel was coke; (c) the composition of "water gas" made by blowing steam over red hot coke.¹

TABLE XXVI
Composition of Gases by Volume

	(a) Producer gas	(b) Air gas	(c) Water gas
Carbon monoxide	27.6	32.6	44.0
Carbon dioxide	3.9	1.4	3.3
Hydrogen	15.3	1.0	48.6
Methane.....	1.4		0.4
Nitrogen, etc.....	51.8	65.0	3.7
Total combustible gases.	44.3	33.6	93.0
Fuel.	Anthracite	Coke	Coke

Anthracite and coke, the fuels used in generating the gases whose compositions are given above, contain a very large proportion of fixed carbon, typical analyses of these fuels being somewhat as follows:—

TABLE XXVII
Composition of Anthracite and Coke

Fuel	Fixed carbon	Volatile matter	Ash
Pennsylvania anthracite	85.0	8.5	6.5
" coke.....	89.0	1.3	9.7

¹ Taken from Dowson and Larter's "Producer Gas," p. 21, 1906 edition.

It is thus evident that if anthracite or coke of good quality is used in a gas producer, the resulting gas should contain only a very small proportion of hydrocarbon compounds, and this is, in fact, found to be the case.

When gas is to be generated from fuels such as bituminous coal, which contain a considerable amount of hydrocarbon compounds and give off a large quantity of volatile matter on heating, the problem is a much more difficult one, especially if the gas is to be used for power purposes. This is because the working of the producer itself is more complicated than if non-bituminous fuels are used, and the tarry matters and products of distillation, arising when the coal becomes heated, must be dealt with in such a way as to avoid stoppage in the producer itself, in the pipes, and in the passages and valves of the engines. This aspect of the question is considered later, but it may be said here that by adopting special designs of producer and gas cleaning apparatus coals containing as much as 40 per cent of volatile matter have been successfully employed for power gas generation.

GAS PRODUCERS FOR NON-BITUMINOUS FUELS

A sectional view of a gas producer for use with fuel containing little or no volatile matter is given in Fig. 39, from which it will be seen that the arrangement of Fig. 38 is here modified so as to provide for the necessary supply of steam, and the apparatus is intended to be worked as a "suction producer" in which the engine itself draws into the producer the quantity of air needed for its operation. Slight constructive changes would be needed if the producer were of the "pressure" type, in which the air is blown in by a fan, or if the draft were maintained by the suction of an exhauster. The steam needed could, of course, be supplied by a separate boiler, but as this would involve additional expense and would require more or less continuous attention, it is usually desirable, especially in small installations, to arrange the producer so as to generate its own steam. The particular design shown in Fig. 39 is that of Ruston, Proctor, and Co., Ltd., Lincoln, England, but producers of this type are built by many well known firms in Europe and America.

In Fig. 39 the upper part of the producer proper consists of a cast iron vaporizer or boiler, which is heated by the fuel below and is so proportioned as to evaporate as nearly as possible the amount of water required to give steam to the air supply. Fuel is introduced through the hopper **B**. The air enters at **A**, passes over the heated water, and carries the required amount of steam along the pipe **E** leading to the space **C** below the grate. The gas leaving the upper part of the producer passes through a water seal **D** and enters the bottom of a wet scrubber **S** consisting of a cylindrical vessel containing a body of loosely packed coke through which water trickles, thus cooling and washing the gas on its upward passage. From the wet or coke scrubber the pipe **F** conducts the gas into an expansion box **K** and then to the engine. For starting the producer, a small hand fan (not shown) and a waste pipe **G** leading to the atmosphere are provided, so that, when starting, air is blown into the space **C**, the cock **H** is opened to the

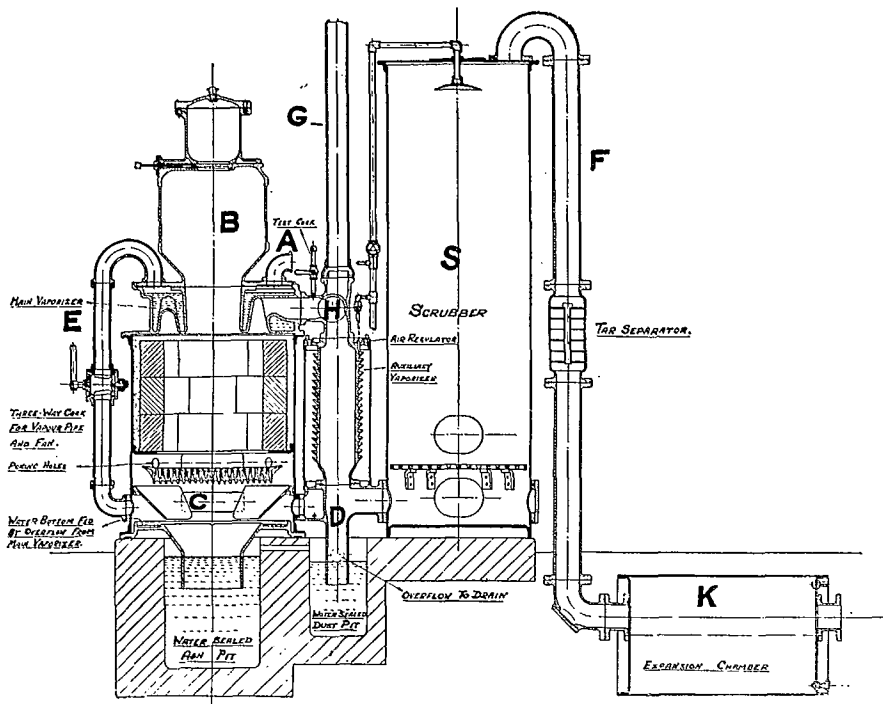

Fig. 39. Suction gas producer.

(Ruston, Proctor and Co., Ltd., Lincoln, England).

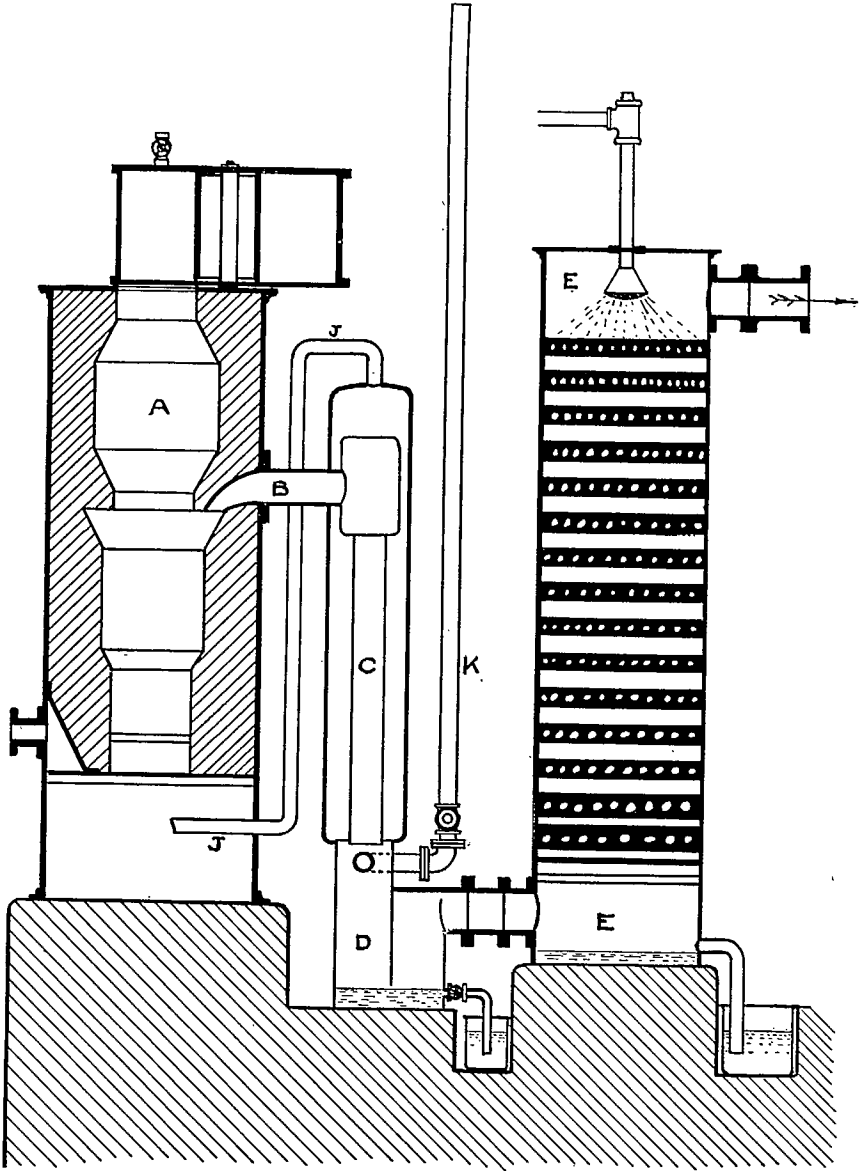

Fig. 40. Suction gas producer (Pintsch).

atmosphere, and the producer works under slight pressure, whereas in regular running the pressure in the whole system is slightly less than atmospheric. Suction producers of this type are in use up to about 500 H.P.; larger producers are usually of the pressure type, in which air is supplied by a blower or steam jet, and the whole apparatus is under a plenum.

It should be noted that in suction gas producers the vaporizer or boiler is frequently placed in the pipe leading to the scrubber, and not in the producer itself. An apparatus of this kind is shown in Fig. 40, which represents the Pintsch suction producer. Here the hot gas from the fuel bed leaving the producer by the pipe **B** passes through a vertical tube **C** in what is really a small boiler, fed by a gravity water supply, and discharging steam at atmospheric pressure by the pipe **J** into the space below the grate of the producer. Automatic adjustment of the steam supply is arranged, so as to suit the requirements of the fuel and load. The producer is provided with a dust trap **D** and the usual wet scrubber **E** and its accessories.

For the operation of an anthracite or coke producer, provision must, of course, be made for poking the fire, for the removal of ash and supply of fresh fuel, and for getting rid of any dust or refuse which may be deposited in the pipes or scrubbers. The chief troubles to be guarded against arise from the formation of clinker in the producer, or from gas explosions in the producer or pipes; also there is the possibility of gas poisoning if any leak or opening permits the escape of gas containing carbon monoxide into the producer room—or engine room. The latter is evidently less likely to occur in a suction plant than in one of the pressure type. A few words regarding these matters will not be out of place.

The term clinker in a gas producer is used to denote the fused ash of the fuel. If the temperature in the incandescent zone of the fuel bed is such that the ash melts as it is formed, there is a tendency for the melted ash or clinker to adhere to the walls of the producer, or to trickle down and cause trouble by solidifying in a cooler part of the fuel bed or in the bed of refuse lying above the grate. Sometimes a ring of clinker grows out from the wall of the producer and seriously interferes with the regular downward movement of the fresh fuel which ought to occur as that below is burnt away. In such a case it is necessary to remove the adherent mass by poking. The trouble may evidently be avoided either by using a fuel whose ash has a high melting point, or by working with a low temperature in the fuel bed. The latter result is easily obtained by increasing the proportion of steam in the air supply, but too low a temperature is undesirable, since it is found that with very low producer temperatures the resulting gas will be high in carbon dioxide and low in carbon monoxide; the calorific value of the gas generated will thus be lessened. The usual temperature in the heated zone of a gas producer is about 1,500° to 2,100° F.¹

The risk of gas explosion in a properly operated gas producer plant is very slight. In order to produce an explosive mixture, the gas after leaving the fuel bed must be mixed with air, and this can only occur through leaky joints

¹ See Bulletin 393, U. S. Geol. Survey, pp. 15-27.

valves, or cocks in a suction plant, or by the improper use of openings, such as ash pit, cleaning, or poke hole doors. The pipe system should always be provided with a sufficient number of water seals, like that shown at the bottom of the gas outlet pipe in Fig. 39, so that the effect of a gas explosion in the piping will simply be to blow out the water in one or more of the seals. When cleaning out a scrubber or gas holder, no fire or light should be allowed in the producer house and all precautions should be taken to avoid possibility of explosion.

Carbon monoxide is the only poisonous constituent of producer gas, but it is inodorous and occurs in sufficient amount to render the gas dangerous to human life if inhaled. Every care should, therefore, be taken to guard against leakage, and the producer house must be well ventilated. When cleaning is to be done it is very imprudent to enter a scrubber, gas holder, or any part of the installation until it is completely cleared of gas, and has been blown out with fresh air. Again, in starting a suction plant care must be taken that the engine is not in such a position that both gas and air inlet valves are open, as in this case gas might possibly be driven through the producer by the starting fan and thence into the engine room. Unburnt gas should not be allowed to escape from test cocks or other orifices into the producer or engine room.

If a man is affected by carbon monoxide poisoning, he should be at once removed into warm fresh air, and if insensible, the first-aid measures required are artificial respiration or the administration of oxygen. Exposure to cold is to be avoided. Although thousands of gas producer plants are in use, few cases of serious poisoning or asphyxiation occur.

On account of the fact that with a suction producer the pressure within the gas system is less than that of the atmosphere, any leakage occurring when the engine is working will be from the air into the producer or piping. With a pressure plant, however, the leakage is outwards, and for this reason such plants require more care to guard against possible leaks.

The efficiency reached by the best gas producers in practice is high. Well designed installations working with suitable fuel have produced gas whose calorific value is as much as 85 per cent of that of the fuel burnt, even in small sizes. It is probable, however, that in every day working the efficiency of the ordinary suction producer does not exceed 75 to 80 per cent, and most installations working with bituminous coal show a considerably lower efficiency than this.

It should be noted that when producer gas containing hydrogen or hydrocarbon compounds is burnt, the heat given up by the products of combustion is greater if the steam formed is condensed than if the steam is not so condensed, because of the relatively large amount of heat given out by each pound of steam in being turned to water. When speaking of the calorific value of such a gas, it is, therefore, necessary to know whether the higher value (allowing for the condensation of any steam formed) or the lower, or effective, value is meant. The two quantities often differ by as much as 10 per cent. It seems right to take the lower value in gas producer

work, since the products of combustion are always above 212°F. when they leave the engine, and the steam they contain, therefore, is not condensed.

GAS PRODUCERS FOR BITUMINOUS FUELS

Gas for use in gas engines must be clean, that is, practically free from dust or tarry matter which will cause obstruction in the passages or undue wear of the working parts of the engine. Such gas should be delivered to the engine at as low a temperature and at as high a density as possible, so that the engine may take in a charge having the greatest possible heat value. The gas should be uniform in quality and uninterrupted in supply, whatever the rate at which the producer is worked, and the operation of the producer plant should involve but little supervision and manual labour on the part of the attendants.

Gas producers using bituminous coals have been successfully used for industrial purposes, such as cement burning, steel melting, and the like, since the introduction of the Siemens producer and furnace in 1861, but such producers are usually of considerable size, and furnish gas which is neither clean nor cool. Freedom from tar, and low temperature of gas, are qualities of little or no advantage for furnace work, and fuel gas producers are, therefore, simpler and less difficult in operation than is the case with producers supplying gas for power purposes. A coal may be capable of giving satisfactory results in a large fuel gas producer, and may nevertheless give trouble when burnt in a producer furnishing gas for power purposes, especially if the producer is a small one. Fuel gas producers¹ will not be discussed here, but the construction and operation of a few leading types of power gas producers will be described, in order to illustrate the special difficulties involved in the use of bituminous fuels. Such fuels form the major part of the world's fuel supply, and power gas plants must be capable of utilizing bituminous coals if they are to compete successfully with steam plants under any but exceptional circumstances. As will be seen from the following notes, however, the design of power gas producers for bituminous fuel is still undergoing development.

The composition of certain typical gases made from bituminous coal for power purposes is shown below:—

TABLE XXVIII

Composition of Typical Gases from Bituminous Coal.

Type of Producer	R. D. Wood	Westinghouse	Mond
Fuel—Moisture	4.21	1.39	2.0
Fixed carbon	53.16	74.28	65.0
Volatile matter	35.41	16.01	27.0
Ash	7.22	8.32	6.0

¹ For a description of typical forms of fuel gas producers see Sexton, Fuel and Refractory Materials (Pub. Blackie and Son), Chap. VII.

TABLE XXVIII—(Continued)

Type of Producer	R. D. Wood	Westinghouse	Mond
Gas (per cent by volume)—			
Carbon monoxide	23.4	18.1	15.3
Carbon dioxide	7.9	7.9	13.2
Hydrogen	17.1	12.6	19.35
Methane.....	2.1	2.6	3.85
Oxygen		0.5	
Nitrogen, etc.....	49.5	58.3	48.3
Calorific value (lower)B.T.U. per cub. ft.	150.0	117.8	141.7

These figures may be compared with those of Tables XXVI and XXVII and with the analyses given later in Table XXXIII (Summary Record of Gas Producer Tests).

If attempts are made to use bituminous coal in producers of such types as are shown in Figures 38, 39, and 40, the first effect of the introduction of a portion of fresh fuel is that a quantity of the volatile matter is driven off by the heat of the already incandescent fuel bed. The resulting gas is then charged with hydrocarbons, the products of partial distillation of the fresh fuel, as well as with dust arising from the ash of the fuel bed. The tarry matter and dust are partly deposited in the pipe system, and partly removed in the scrubber, which rapidly becomes clogged, but a large amount of objectionable material passes over to the engine, where it soon makes its presence manifest by obstructing the ports and passages, and especially the gas and air valves, so that in a short time the engine ceases to work.

But this is not all; if the bituminous coal employed is of a caking quality the fresh fuel will tend to form a more or less solid layer adhering to the walls of the producer, and permitting the formation of a hollow space as the rest of the fuel burns away below. This layer has to be broken down by poking, a process which disturbs the regular operation of the producer, and is liable to cause rapid changes in the quality and composition of the gas generated, even if it does not render the supply insufficient for the engine. The resistance of the fuel bed to the passage of the gas will also change, and this change will be shown by an increase or diminution of the pressure in the producer and pipe system. In fact, it will be found that an ordinary suction producer equipment which will work perfectly with coke or anthracite fails entirely when tried with bituminous coal, even of non-caking quality. Difficulty from the sticking or hanging of the fuel bed will, of course, be more serious in a small producer than in a large one, for if the producer is of sufficiently large diameter the fuel layers will tend to break down under their own weight without the use of the poker.

Successful power gas producers for bituminous coal must, therefore, provide means for:—

(1) Destroying or removing the tarry matter arising from the fresh fuel charged.

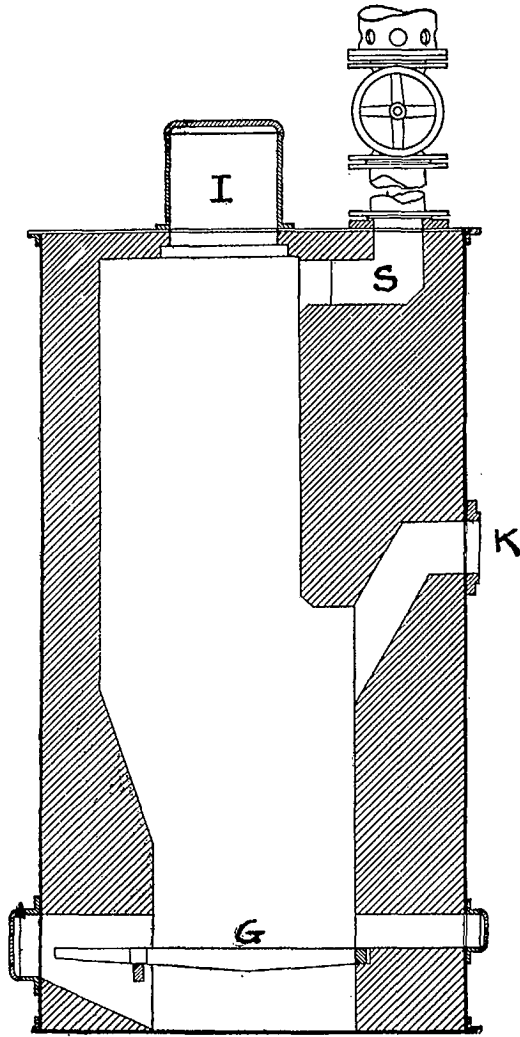

Fig. 41. Gas producer for lignite briquettes (Koerting).

(2) Ensuring a uniform downward movement of the charge as the fuel is consumed, without excessive manual labour, thus obtaining continuous and uniform quality of gas.

(3) Avoiding the loss arising from unburnt carbon in the refuse, and

(4) Removing refuse without disturbing the operation of the producer.

The methods by which these ends have been more or less completely attained in actual producers will be seen from the descriptions which follow.

The products of distillation from bituminous coal, wood, peat, or other non-anthracitic fuel contain various hydrocarbon compounds, which tend to break up into simpler forms, chiefly methane or marsh gas (CH_4), when heated to a temperature corresponding to a bright red heat, this process being often accompanied by the deposition of carbon in the form of lamp black or soot. Hence, if the vapours arising from the fresh fuel in a bituminous producer be drawn through the most highly heated zone of that or of a second producer, the whole or the greater part of the tar will be decomposed or burnt and further difficulty avoided¹ unless the lamp black gives trouble.

The only other alternative is to remove the tar by some kind of washing or cleaning process applied to the gas after it leaves the producer.

The Koerting producer (Fig. 41) is designed for use with briquettes made from lignite, and may be taken as an example of the type in which the tarry matter is destroyed by exposure to a high temperature within the producer. This apparatus is similar in general principle to a producer patented by Dowson in 1903, and consists of a vertical body some 8 or 10 feet in height, arranged as shown, with a grate **G** at the bottom, and a gas outlet **K** about half way up. Air is admitted both at the top and bottom of the producer, and when running on lignite, which contains from 15 per cent to 30 per cent of moisture, good gas can be obtained with fair efficiency without the admission of additional steam. The gas outlet is so formed that as much as possible of the air entering at the fuel inlet **I** must pass through the heated zone of the fuel before reaching **K**. A passage **S** which leads from the top of the producer to the atmosphere is used for starting, and is closed by a valve during regular running. Provision is made for judging the condition of the fire and for poking, as required, by means of proper sight holes and poke holes. The position of the zone of highest temperature can be regulated by varying the relative amounts of air admitted at the top and bottom openings, in such a manner that the products of distillation from the freshly charged fuel are properly decomposed. The lower portion of the producer when working well contains only coked fuel resting on a bed of ash. The whole apparatus may be regarded as a combination of the so-called up-draft and down-draft systems, the passage of the gases being downwards in the upper and upwards in the lower portion. Such a producer would probably not work equally well with caking bituminous coal, as this fuel sticks or hangs in the producer much more than lignite, and poking in a deep producer of comparatively small diameter is not easy.

¹ For a discussion of various methods of dealing with the tar difficulty in bituminous producers, see "Engineering," Jan. 31, and Feb. 7, 1908.

A producer plant in which the tar is decomposed in a second separate bed of hot fuel is shown in Fig. 42, which represents the Power and Mining Machinery Co.'s arrangement of twin producers—known as the “Loomis-Pettibone” system—a scheme very similar to that originally proposed in England by Sutherland in 1882, and since tried by many other experimenters.

In this arrangement two producers or generators, connected at the top, have valves **A** and **B** leading from the spaces beneath the grates to a boiler or vaporizer. From the top of the vaporizer valves **C** and **D** conduct the cooled gas to either of two gas holders. Fuel is introduced through the hoppers **E** and **F**. The producers are worked in such a way that the products of distillation from the generator that has last been cooled have to pass through the hot coked fuel in the other generator. There are several ways of doing this. One method is to work the two generators in parallel, with down-draft, supplying air only, until the temperature rises sufficiently. During this period the tar from the top of each producer is decomposed in its own heated zone of coked fuel (anthracite or coke can be used for starting). The valves are then manipulated so that on supplying steam (without any air) to the base of (say) producer No. 1 and thus running it for water gas with up-draft, all gases distilled pass downwards through producer No. 2 and are there freed from tar. During this “water-gas run” both producers will fall in temperature, as the reactions occurring absorb heat instead of developing it, and the water gas produced, which is rich in hydrogen,¹ is usually led to a separate gas holder. When the action has proceeded sufficiently, steam is shut off and air admitted to both producers, which are worked down-draft as before, so that an “air-gas run” is made during which the producer temperatures rise, but will evidently be higher in No. 2 than in No. 1 where the water-gas has been made. A second “water-gas run” is then made, but this time the steam is supplied to the base of No. 2, while the gases pass downwards through No. 1 where the tar is dealt with. Another air blow follows, and the process is repeated indefinitely. Fuel can be charged into either producer while it is working with open top during the “air blow” period.² Installations of this type have given excellent results, but there is often some difficulty in effecting the proper removal of ash and clinker without interference with continuous operation, and close attention is required in order to maintain the uniform quality of gas and regular sequence of operations. The gas produced from bituminous coal is, however, of a good quality, and such plants are capable of economic working and good efficiency.

As an example of another arrangement for dealing with bituminous coal by destroying tar, the Westinghouse “double zone” producer, introduced in 1909, may be selected. This apparatus, like the Koerting producer, is generally similar in principle to the Dowson producer of 1903, but contains means for generating the steam it requires. It has no grate, the refuse being removed through a water seal at the base, and the plant includes many novel accessories

¹ See p. 57.

² For an account of a test on a producer plant of this kind see Trans. A.S.M.E., Vol. 29, p. 725.

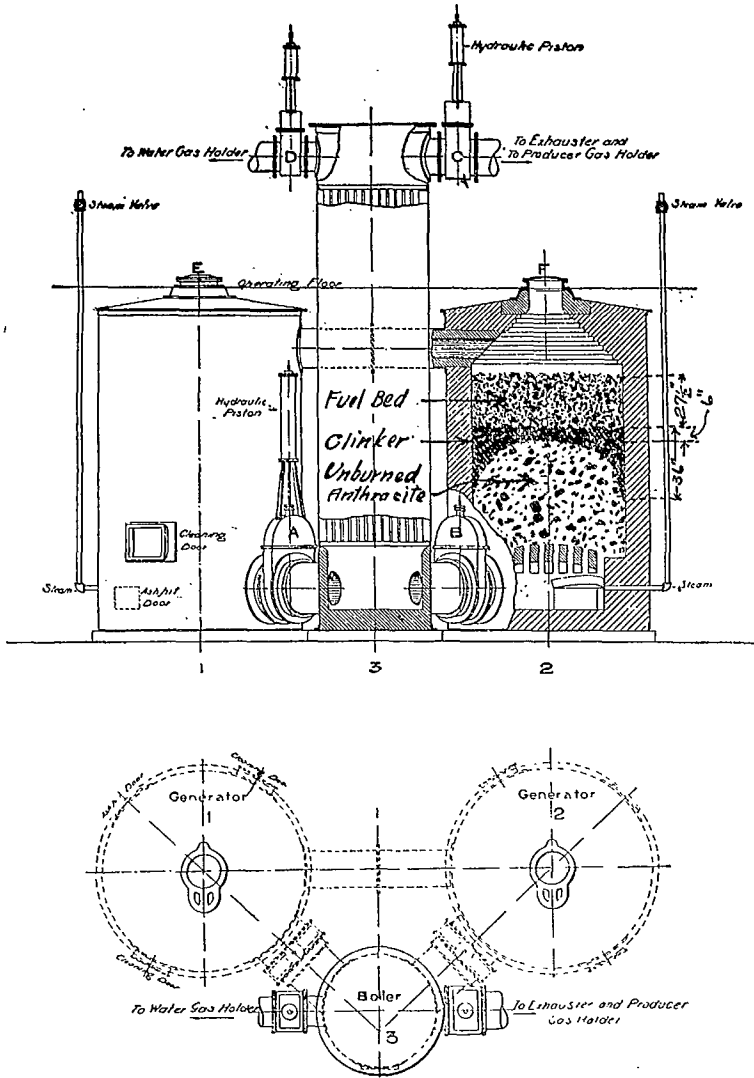

Fig. 42. Twin down draft gas producers. (Power and Mining Machinery Co.).

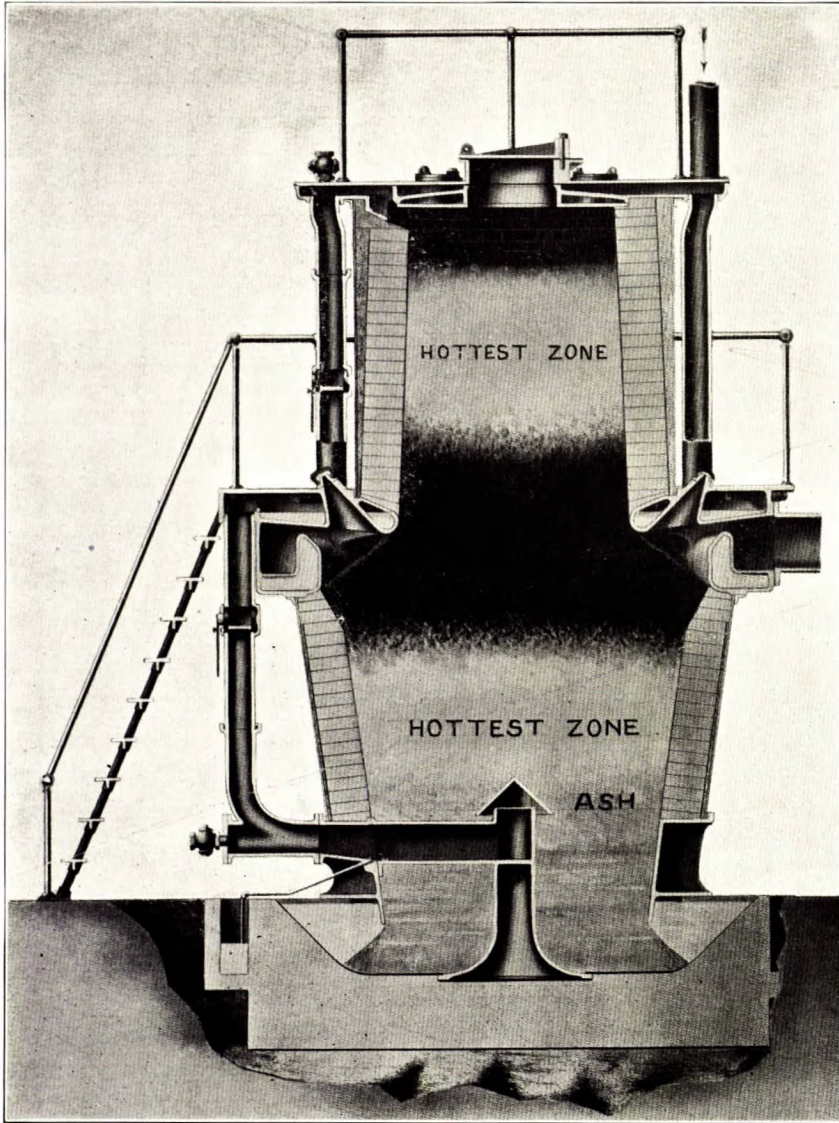

Diagram of Westinghouse double zone producer vertical section.

and features of construction. The producer is shown in Plate XLVII and in Fig. 43¹ from which it will be seen that the cast iron vaporizer, containing the gas outlet passage and a series of poke holes, divides the producer into an upper and a lower portion of different diameters. An air inlet pipe admits air to the steam space of the vaporizer, and vapour pipes, provided with supplementary air admission cocks, lead respectively to the spaces at the top of the upper portion of the producer and to the ash bed just above the water seal. Air and steam in any desired mixture can, therefore, be supplied to the fuel bed either at top or bottom, or at both, and the gas produced is drawn off by an exhauster from the central zone to the gasholder (if used) and engine. Sight holes enable the operator to judge of the condition and location of his fire. When in regular operation freshly charged fuel forms the top of the fuel bed, and rests on a layer of incandescent coked fuel through which the products of distillation pass. Towards the middle level of the producer the fuel is at a lower temperature, while the coke is completely burnt and another zone of combustion occurs near the bottom of the lower part of the producer. In connexion with this make of producer, a gas-washer of special type designed for the removal of dust, a mixing header, and a special pressure regulator are employed.

The producers so far described are of the type in which the tarry matter is destroyed by exposure to a high temperature or burnt by a special air supply. Many successful power gas plants, however, are in use in which the tar is removed from the gas, together with the dust, by power driven washing and cleaning apparatus. The producer plant successfully used by the U.S. Geological Survey in their St. Louis tests² was of this kind.

Probably the largest and most highly specialized power gas installations now at work are those using the Mond process,³ in which the gas is mechanically cleaned, and this system is of considerable interest, especially as provision can be made for recovering certain of the by-products (such as ammonium sulphate) which are of commercial value. The Mond producer is of the up-draft type with a water sealed bottom. It is worked under slight pressure from a blower, and the entering air is mixed with a large amount of steam (about $2\frac{1}{2}$ times the weight of coal burnt), with the object of keeping down the producer temperature, so that any ammonia formed may be recovered and there may be no trouble from clinker. The hot gas leaving the generator is, therefore, mixed with much undecomposed steam, and this mixture gives up its heat in a regenerator to the incoming blast. The gas is then passed through a mechanical washer, and enters special cooling towers where the ammonia is abstracted. Ammonia recovery is not usually practised in plants burning less than 30 tons per day, and the system as a whole is not easily applicable to small powers.

¹ Taken from the Westinghouse Machine Co.'s circular W.M. 503.

² See U. S. Geol. Survey., Professional paper No. 48, Report of Coal Testing Plant, Part III.

³ See Humphrey, Power Gas and Large Gas Engines for Central Stations: Proc. Inst. Mech. Eng., 1901, p. 41. Also Case, Jour. Soc. Chemical Industry, 1905, p. 596.

There are many designs of mechanical gas washers, most of which appear to be completely effective only within a somewhat narrow range of speed and temperature. All involve the expenditure of a considerable amount of water and power, and their use takes from the gas a portion of its combustible matter. The gas is cleaned by means of a modified fan or corresponding centrifugal apparatus in which finely divided spray catches the dust particles and carries them off, the spray and refuse being separated from the gas by centrifugal action. These machines are used on a large scale for cleaning blast furnace gas¹ for power purposes, as well as for producer gas.² For satisfactory use in an engine, power gas should not contain more than 0.03 grain of solid matter per cubic foot, and the gas ought, at least, to be purified to this degree.

In large installations gas can be thus cleaned at an expenditure of about 2 per cent of the power to be developed by the gas dealt with.

In several types of gas plant (as for example the Wilson producer plant) a thorough cooling of the dry gas is carried out and is found to facilitate the removal of tar and dust by subsequent washing, because the particles to be dealt with are more readily wetted and entangled in the spray when the gas is cool than when hot. The tar and dust are, of course, partially deposited in the cooling pipes, which are so designed as to permit of easy and frequent cleaning.

GAS PRODUCER TESTS AND METHODS OF TESTING

The selection of proper and reliable methods in gas producer tests is one of the most difficult problems which confront the gas engineer,³ and when such tests are to be used, not to determine the efficiency of a given producer, but to investigate the relative suitability of various coals for gas producer use, as in the case covered by this report, the difficulty is not at all diminished. As in the case of boiler trials, it seems at first sight a simple task to measure the fuel supplied to, and the heat value of the product delivered from, the apparatus under test, in a given time, but when the work is attempted practical difficulties at once present themselves, and with a gas producer using bituminous coal troubles inherent in the nature of the work to be done render the matter still more complex.

The main objects of a gas producer test, for whatever purpose it is made, must be to measure or determine:—

- (1) The amount and calorific value of the fuel consumed by the producer in a given time;
- (2) the amount of the heat value of this fuel actually utilized and available in the gas supplied during the test interval to an engine or furnace;
- (3) the amounts or items by which the loss or difference between (1) and (2) can be accounted for;

¹ For a description of a large installation of "Theisen" washers for a blast furnace gas power plant, see Trans. A.S.M.E., June, 1910.

² For satisfactory use in an engine, power gas should not contain more than 0.03 grain of solid matter per cubic foot, and the gas ought, at least, to be purified to this degree.

³ The whole question of standardizing gas producer tests is now (1910) under consideration by a Committee of the American Society of Mechanical Engineers.

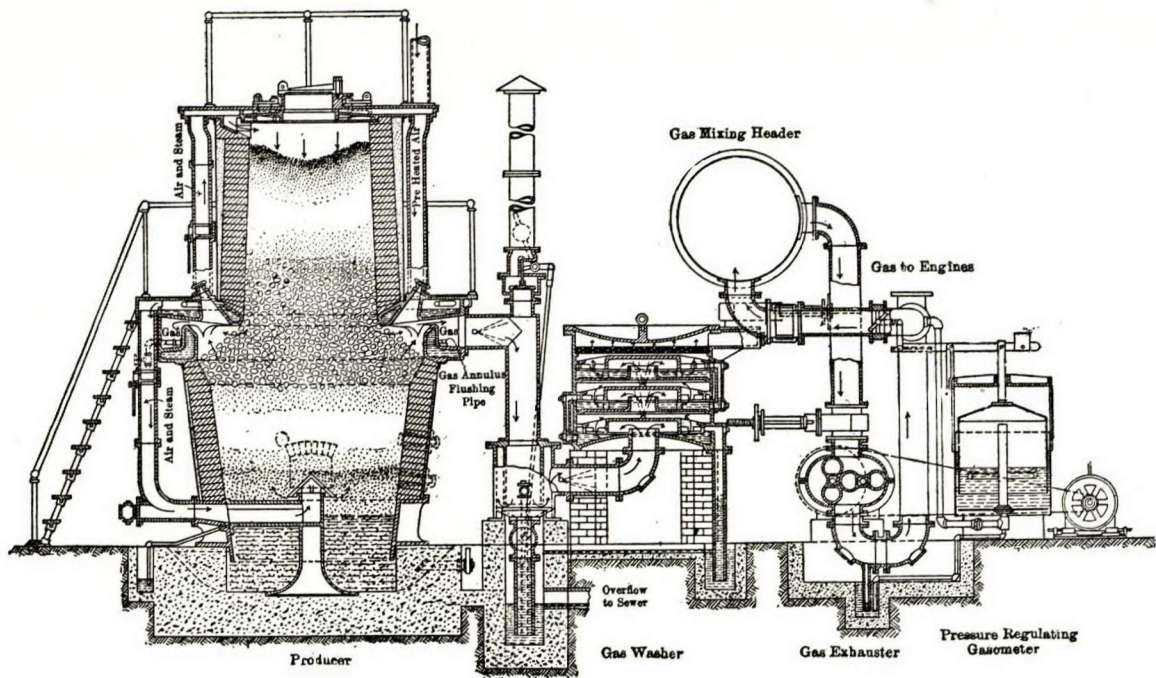

Fig. 43. Double zone gas producer (Westinghouse).

(4) the suitability of the gas for its intended use and the reliability and freedom from trouble of the producer when in service with the fuel to be employed.

The first difficulty occurring is that of determining the coal consumption, for a producer contains a deep bed of fuel, which as a rule can only be seen imperfectly at a few small sight-holes, and which may be composed to an unknown degree of red hot ash and refuse indistinguishable to the sight from good fuel. If at the end of a run one could judge the state of the fuel bed, and could be certain that its condition was exactly the same as at the commencement, this difficulty would disappear, and the coal fired or charged into the producer would be the same thing as the coal consumed. Actually there may be considerable discrepancy between these quantities, even in a comparatively long test, and the gas delivered by the producer may have been derived from a quantity of fuel greater or less than the amount actually charged into the producer.

The *rate of fuel consumption* may be computed in three ways:—

(a). From the weight of coal fired, and an estimate of the difference between the fuel value of the contents of the producer at the beginning and at the end of the test period. In this estimate some assistance may be obtained from chemical analyses giving the composition of the ash and refuse drawn from the producer during the test and of the fuel bed (including its ash and refuse) at the end of the test.

(b). From a sufficiently complete analysis of the gases produced, a measurement of their amount, and a knowledge of the chemical composition of the fuel, a calculation can be made showing the amount of fuel required to produce the known quantity of gas, assuming that all of the carbon in the fuel consumed reappears in the gas generated.

(c). In a small producer, which can be mounted on a weighing machine and weighed continuously during the trial, the total weight lost between the times at which fuel is added indicates the amount of combustible consumed and moisture driven off; from this and other considerations the fuel consumed may be estimated.

Each of these methods has its drawbacks, but on the whole if a trial of sufficient length can be made it seems best to use (a), with proper precautions as to treatment of refuse, etc., although this method involves several serious sources of error, and correct judgment of the fuel bed conditions is almost impossible. The method (b) of working from gas and fuel analyses necessitates arduous and accurate chemical work, and even when correct and complete analyses are available, an unknown amount of volatile or gaseous constituents derived from the fuel may have been dissolved in and carried off by the scrubber or washer water, or may have been condensed or deposited in the pipe system. Tests of considerable length worked out in this way often yield results not in good agreement with the known rate of fuel weighing, and it is seldom possible in commercial tests to measure the amount of gas produced. The third method can obviously only be used with small producers; it is still necessary to allow for differences in the condition of the fuel bed,

and a long run is needed in this case also, since the total weight of the producer and charge is great as compared with the small losses or gains in weight which have to be determined.

In order to carry out method (a) in a satisfactory manner, the following points must receive careful attention.

(1) When the trial begins the producer must have been running at its intended rate of working, and with the fuel to be employed during the test, for a length of time sufficient to get the fuel bed into regular working condition. This will usually need from three to ten hours, depending on the rate of working and amount of fuel in the producer.

(2) Fuel must be added, and refuse removed, at stated intervals and in uniform quantities, so as to ensure as constant a condition of fuel bed as possible. The level of the fuel in the producer must be kept as uniform as possible throughout the trial. It is not sufficient simply to have the level of the fuel the same at the end as at the beginning of the test; for example, if this result is obtained by filling in a lot of fresh coal just at the conclusion of the trial period, there will evidently be a great difference in the fuel bed condition at the end as compared with that at the beginning.

Poking or disturbance of the fuel bed must be avoided as much as possible. This rule is often very difficult to carry out, especially with small producers and those using bituminous coal, on account of irregularities in operation due to sticking of the fuel bed or formation of hollows within it, in which case poking and irregular charging are unavoidable.

The length of test should be such that the possible error due to wrong estimation of the fuel content of the producer is small, say $2\frac{1}{2}$ per cent to 5 per cent. This can seldom be arranged for, and it is doubtful whether many published tests of gas producers are accurate within these limits. In order to form an idea of the length of continuous run required, we may take, for example, a gas producer like that used in the U.S. Geological Survey tests,¹ having a fuel bed 7 feet diameter and containing about 160 cubic feet (or 8,000 pounds) of coal, excluding the volume of the ash bed. It is evident that in this case when working at a rate of about 15 pounds of coal per square foot of cross section of fuel bed per hour, or 570 pounds per hour, no less than 14 hours run will be required to consume a weight of coal equal to the fuel content of the bed. An error of 20 per cent, or 1,600 pounds, may easily be made in assuming the combustible content of the fuel bed to be the same at the beginning and at the end of the trial; hence, if the final coal consumption is to be correct within ± 5 per cent, at least 32,000 pounds must be fired, or the test run must be continued for about 56 hours. On a 24 hour run the possible error would then be nearly ± 12 per cent, and similar figures hold for producers of other sizes,² the possible error depending on the rate at which the producer is worked.

¹ U. S. Geol. Survey, Professional Paper No. 48, Report of Coal Testing Plant, 1906, part III, p. 984.

² See also U. S. Geol. Survey Bulletin 393, "Factors affecting proper length of tests."

The input of the producer having been determined in the form of the number of pounds of fuel consumed, multiplied by its calorific value¹ per pound, the test must also include the measurement of the output, which is evidently the quantity of gas produced (usually in cubic feet) multiplied by its calorific value per cubic foot.

The *quantity of gas* may be found either (a) by passing it through a meter, which should be calibrated before and after the trial, at the proper rate and under the proper conditions of working; or (b) by a Venturi meter or by a Pitot tube; both these methods involve very careful and troublesome work if reliable results are to be obtained. A third method (c) requires the use of a gas holder of known capacity, the rise of which is noted over a period during which the whole of the gas from the producer is being discharged into it. The gas holder method is apparently simple, but very few gas plants are equipped with holders containing more than a few minutes supply, and difficulties are liable to arise from the bulging of the gas holder drum, rapid and uneven changes of temperature and pressure of the gas while the measurements are made, time lost in working valves, and from other causes, all of which may militate against the accuracy of the results. The meter method is usually the most satisfactory, although the cost of an efficient and accurate meter is large and the difficulty of calibrating it is considerable.

The *quality of gas* as indicated by its calorific value is best determined for practical purposes by burning the gas in an apparatus, such as the Junker or Boys' calorimeter, in which a metered volume of gas gives up practically all the heat generated to a continuous stream of cooling water, and this heat is measured by the rise in temperature of the cooling water as it passes through the calorimeter. Special difficulties arise when dealing with weak gas of low calorific value, in which case it is not easy to ensure complete combustion.² A description of such a calorimeter is given later. The calculation of the calorific value from the chemical composition of the gases is useful as a check, although difficulties in obtaining frequent and representative samples and the laborious nature of a complete analysis, render this method of comparatively little use in commercial work.

In connexion with the quality of the gas furnished by a producer, a satisfactory test should give complete information as to the suitability of the gas for its intended purpose, and this is not necessarily obtainable merely from the calorific value or chemical analysis. Among the points on which observations may be made are:—

(1) Amount of tar carried by gas and deposited in pipe system or entering engine.

(2) Kind and quantity of dust, collected in pipe system, removed by scrubber, and carried over to engine.

¹ Methods of determining the calorific value of fuels are discussed in Part IX of this Volume. See also Part VII.

² For example of calculations with, and operation of, the Junker calorimeter, see Proceedings Inst. Mech. Engineers for 1908, Third Report to Gas Engine Research Committee, Appendix II. This also gives valuable information as to gas analysis methods for gas engine work.

- (3) Amount of soot or lampblack formed or carried by gas.
- (4) Temperature of gas supplied to engine, and leaving producer.
- (5) Pressure or vacuum in producer and in various parts of pipe system; fluctuations in pressure during operation.
- (6) Uniformity in amount and quality of the gas.

Tar and dust are most readily measured by filtering a measured quantity of gas through special filter shells or papers. The amounts deposited in the pipe system can only be determined by periodical cleaning.

Observations of *temperature of gas leaving the producer* are extremely valuable as an aid to effective control of the producer's working. Sudden or gradual changes in this temperature indicate alterations in the working condition of the fuel bed, which can then usually be dealt with in time to avoid trouble from considerable variation in calorific value or pressure of gas. Fluctuations in calorific value or gas pressure are especially troublesome when they necessitate continual alterations in the adjustment of the engine valves.

When testing various coals in a gas producer, it is necessary not only to make such observations as are possible on the efficiency and economy of the producer with the various coals tested, but also to record any information obtainable as to the relative adaptability of the various samples for operation in the producer. Experience gained in regard to the following points is valuable:—

- (1) Labour required to handle the coal and work the fire in the producer. This is affected by the caking and clinkering qualities of the coal itself, and by the fact that the producer may be operated with fuel bed conditions unsuited to the particular fuel under test. For instance, an insufficient supply of steam may lead to trouble from clinkering with a coal which would work well with a lower producer temperature. Or, the producer used may be of a design unsuited to the particular fuel.

- (2) Labour required to handle ashes and refuse.

- (3) Trouble arising from tar and volatile matter in coal.

- (4) Trouble arising from packing of the fuel bed, due to necessity for excessive local poking, or due to the particular size and nature of the pieces of fuel. For example, with certain lignites, which break up into small pieces on heating, or with certain sizes and kinds of anthracite, trouble from packing may easily occur.

- (5) Effect of depth of fuel bed on the working of the producer with each coal. Fuels such as peat will require for efficient working a depth of fuel bed very different from that which will give good results with a fuel such as hard coal.

- (6) Trouble arising from deposition of soot or lampblack. This material, if deposited in the producer, often seems practically incombustible, and is very difficult to deal with.

- (7) Difficulties due to nature and amount of sulphur in coal. These have been occasionally manifested in prolonged runs with certain coals, and have caused corrosion of iron work exposed to the moist gas.

(8) Effect of inherent moisture of coal on the amount of steam required. This is very marked in lignites, many of which work well in a producer without any steam supply at all.

The accurate estimation of the various individual *heat losses* in a gas producer test is almost impossible, as will be seen when we consider the difficulties surrounding the measurement of the various quantities on which such estimation depends. For the ordinary commercial testing of producers, or for a series of tests like that now reported, intended as a basis of comparison of various coals, such detailed results are fortunately not necessary. The losses in question may, however, be indicated below. The chief items are:—

Losses in producer itself:—

Radiation.

Heat lost in ash and refuse withdrawn.

Heat lost in evaporating moisture in coal.

Heat value of combustible in ash and refuse withdrawn.

Heat value of carbon or soot deposited in producer.

Losses in piping, vaporizer, scrubbers, and gas cleaning apparatus:—

Radiation.

Heat used in warming water in scrubber and washer and in saturating gas with water vapour.

Heat value of combustible deposited in vaporizer and piping.

Heat value of combustible dissolved and carried off by scrubber and washer water.

And finally:—

Heat carried away to gas holder or engine due to high temperature of gas.

The heat expended in the formation of the necessary steam supply would be a loss if the producer did not generate its own steam. The heat value of gas or coal corresponding to the power used in driving, washing, blowing, or exhausting machinery should, of course, also be taken into account.

The practical results obtained with actual producers show that having regard to all these losses, their total amounts appear to be about as follows:—

Kind of Producer.	Total losses in producer plant per cent of calorific value of coal fired, full load
Suction producer, small size, using anthracite	15% to 25%
Suction producer, large size	10% to 20%
Small producer using bituminous coal	25% to 45%
Large producer using bituminous coal with regenerative plant, etc.	20% to 30%

When the producer is worked below its proper capacity, the efficiency is, of course, appreciably diminished.¹

¹ Very complete tests (under varying conditions of output) on a Mond bituminous coal producer are given by Professor Bone in the Journal of the Iron and Steel Institute, 1907, p. 126, 1908, p. 206.

In practice, the quantity which is of paramount interest to the power user is not the efficiency of his producer alone, but the overall efficiency of power production from coal pile to engine shaft, and this is fortunately measured more easily than the separate efficiencies on which it depends.

EQUIPMENT OF EXPERIMENTAL PLANT FOR GAS PRODUCER TESTS OF CANADIAN COALS

From the preceding paragraphs it is possible to obtain some idea of the difficulties which have been encountered in successfully operating an experimental gas producer plant while testing samples of all types of coal and lignite now worked commercially in the Dominion of Canada. These fuels differ widely in composition, and vary in character from a true lignite containing 10 per cent of ash, 30 per cent of volatile combustible, and 25 per cent of moisture, to an anthracite with 78 per cent of fixed carbon, only 12 per cent of volatile matter, and hardly any moisture. Samples from the extreme west of the Dominion and from the Maritime Provinces, as well as from intermediate regions, had to be treated, and questions of transportation, storage, and handling had to be considered.

The conditions of the case were, therefore, such that it was necessary to use quantities only just large enough to be capable of giving the required results, and in settling the capacity of the experimental producer plant it was decided to work on a comparatively small scale. Each lot of coal had to furnish sufficient material for chemical work, boiler tests, and, in many cases, coal washing and coking tests, as well as for the producer work. It is well known that operating difficulties are less noticeable in a large than in a small producer plant, and it was desired, if possible, to test the suitability of the various Canadian coals for use in a producer plant of a size beyond the needs of the small power consumer. The installation of an engine and producer plant capable of giving 30 to 40 B.H.P. was, therefore, resolved upon, and at the end of 1906, a 40 B.H.P. four cycle horizontal engine was ordered from the National Gas Engine Co., Manchester, England, together with a suction producer, known as No. 1, and the necessary scrubbers and accessories. All were of standard commercial type, and designed for use with anthracite coal. On delivery, the machinery was installed in a building erected for the purposes of the tests, and orders were placed for the gas washer, gas holder, exhauster, gas meter, and other apparatus required for test purposes. In the meantime the question of a producer of a type capable of dealing with the various bituminous coals was carefully considered, and after communicating with leading builders on both sides of the Atlantic, proposals were submitted (among many others) from such makers as Crossley Brothers Ltd., Manchester, Koerting Bros., Hanover, the Gas Motoren Fabrik, Deutz, the De La Vergne Machine Co., New York, and the R. D. Wood Co., Philadelphia. None of these firms were prepared to give a definite undertaking that their producers would handle all the coals to be dealt with during the tests, although several were ready to guarantee success with lignite only.

One company (not named above) finally offered to build an experimental producer (No. 2) which was to be accepted if it met the test requirements. This producer was, therefore, built and tried in March, 1907, with encouraging but not completely satisfactory results, trouble being experienced from tar. The builders then announced that they were unable to expend any more money in experimental work and it was necessary to reject the producer. Later, a communication was received from a Canadian firm, stating that they were prepared to furnish a 100 H.P. suction plant to handle any grade of coal, the producer to be built by Julius Pintsch, of Berlin, Germany. Although this would have involved working on a larger scale than was intended, the proposition was considered; but in February, 1908, after much correspondence and inquiry, the Pintsch Company refused to guarantee results unless they had a large sample of each kind of coal delivered to them in Berlin, so that the producer might be specially designed. It was obviously impossible to comply with this requirement.

In the meantime, further correspondence was carried on with certain American companies, who claimed to have been making and working with success small bituminous producers, but investigation was followed by no useful result, as the claims made were in no case substantiated.

At the beginning of 1908, it seemed impossible to obtain from any responsible builder a small producer which would be capable of dealing with all the bituminous coals likely to be submitted for test, but it was known that a number of experimenters were at work on the problem and that successful developments were likely soon to take place. In these circumstances a new specification for a small bituminous producer was drawn up and sent out to a number of leading manufacturers. As a result, in February, 1908, a Canadian firm undertook the construction of a 40 H.P. producer which would successfully handle bituminous coals of certain specified grades, they agreeing to supply and erect the producer in Montreal and to remove the plant at their own expense if the results were not in accordance with their guarantee.

This producer (No. 3) was submitted to a series of tests extending over the period from June to September 1908. Alterations were made from time to time with a view to obviating the various troubles experienced with poor gas, tar, dust, and soot; but although dealing with a non-caking coal containing only a moderate amount of volatile matter and low in ash, it was found impossible to undertake continuous running with this producer, and the apparatus was finally removed from the laboratory.

The time spent in experimenting with and trying producer No. 3 was thus wasted, as far as the prosecution of the series of tests on Canadian coals was concerned; the period was, however, utilized as far as possible in getting the remainder of the plant into thorough running order. Changes were made in the gas washer, improving its performance and reliability, the pipe arrangement was modified, the meter system calibrated, and a series of tests run with the suction producer on anthracite and coke to accustom the staff to test conditions, and to make sure that a good working arrange-

ment had been installed. The apparatus for gas analysis and calorimetry was also fitted up and adjusted.

During the long period of correspondence and inquiry, it had become evident that no builder could be found who was able to guarantee the satisfactory operation of so small a producer with bituminous coal, although several would have undertaken the task if a plant of larger capacity could have been installed. Careful study of the various designs submitted, however, seemed to indicate that it would be possible to design a simple producer more suited for the special conditions of this case than any of those offered. In January, 1908, it was felt that a producer of the down-draft water-seal type should be tried (in spite of the low efficiency to be expected with some coals with a producer of this kind), inasmuch as this type of producer is the only one which can be worked with an open top and which affords complete facility for poking and thus dealing satisfactorily with caking coals. Such a producer (No. 4) was accordingly designed by Professor Durley.¹ It was ordered on March 26, 1908, was built in Montreal, and delivered and erected within five weeks. Satisfactory preliminary trials were made in May, 1908, and after some delay caused by the unsuccessful experimental work on producer No. 3, four satisfactory runs, each of twenty-four hours duration, were made with producer No. 4 on two purchased samples of bituminous coal, of which one contained 36 per cent of volatile matter and 11 per cent of ash.

During these trials good gas was made, the engine carried its load well and continuously, and the scrubbing and washing apparatus dealt satisfactorily with the comparatively small amounts of tar and dust which left the producer. In order to avoid further delay, it was, therefore, decided to run the official coal tests on producers Nos. 1 and 4, the former being used only for anthracite and the latter for all other fuels. It may here be said that No. 4 producer was found to work satisfactorily with all of the coals tested, although its efficiency was lower with caking coals than with non-caking coals on account of the considerable proportion of unburnt fuel which passed through the water-seal when continual poking had to be resorted to.

In the case of the anthracite samples, it was, of course, advantageous to be able to run tests on a suction producer of standard design in order to test the suitability of these coals for use with an apparatus of this type.

Building.—In order to accommodate the gas producer and engine equipment, a light and well ventilated building 75 feet \times 18 feet was erected, having 16 feet clear head room and provided with a hand crane of 2,000 pounds capacity. The producers were installed at the west end, and the engine, gas holder, and auxiliaries were arranged so as to leave the necessary room for access and attendance. The building had a steel frame, with walls of two thicknesses of wire lath coated with cement plaster. The roof was of the usual wood, tar, and gravel construction, and the floor of cement.

¹ Drawings and a description of this producer are given later, see p. 75, Plate XLVIII and Fig. 45.

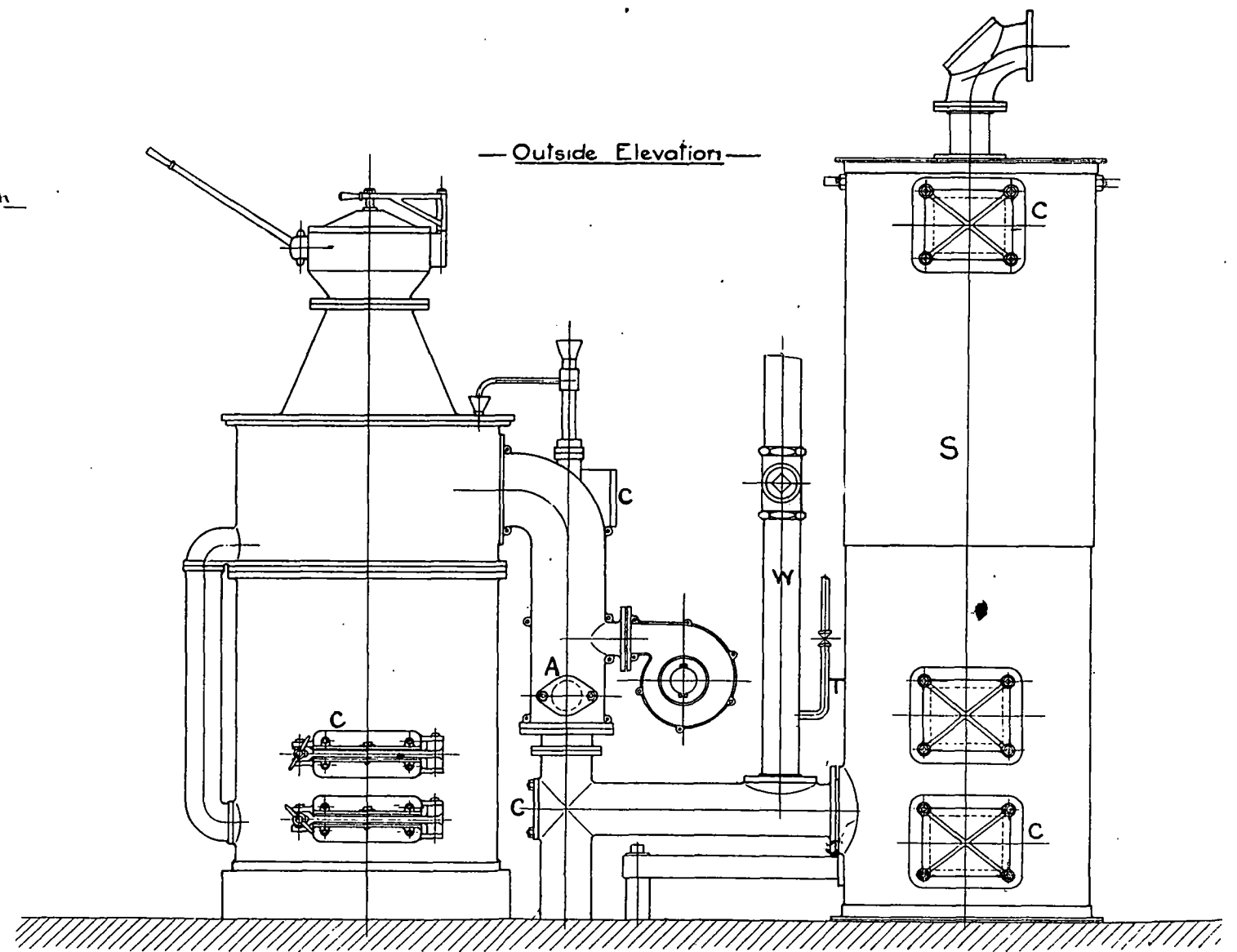
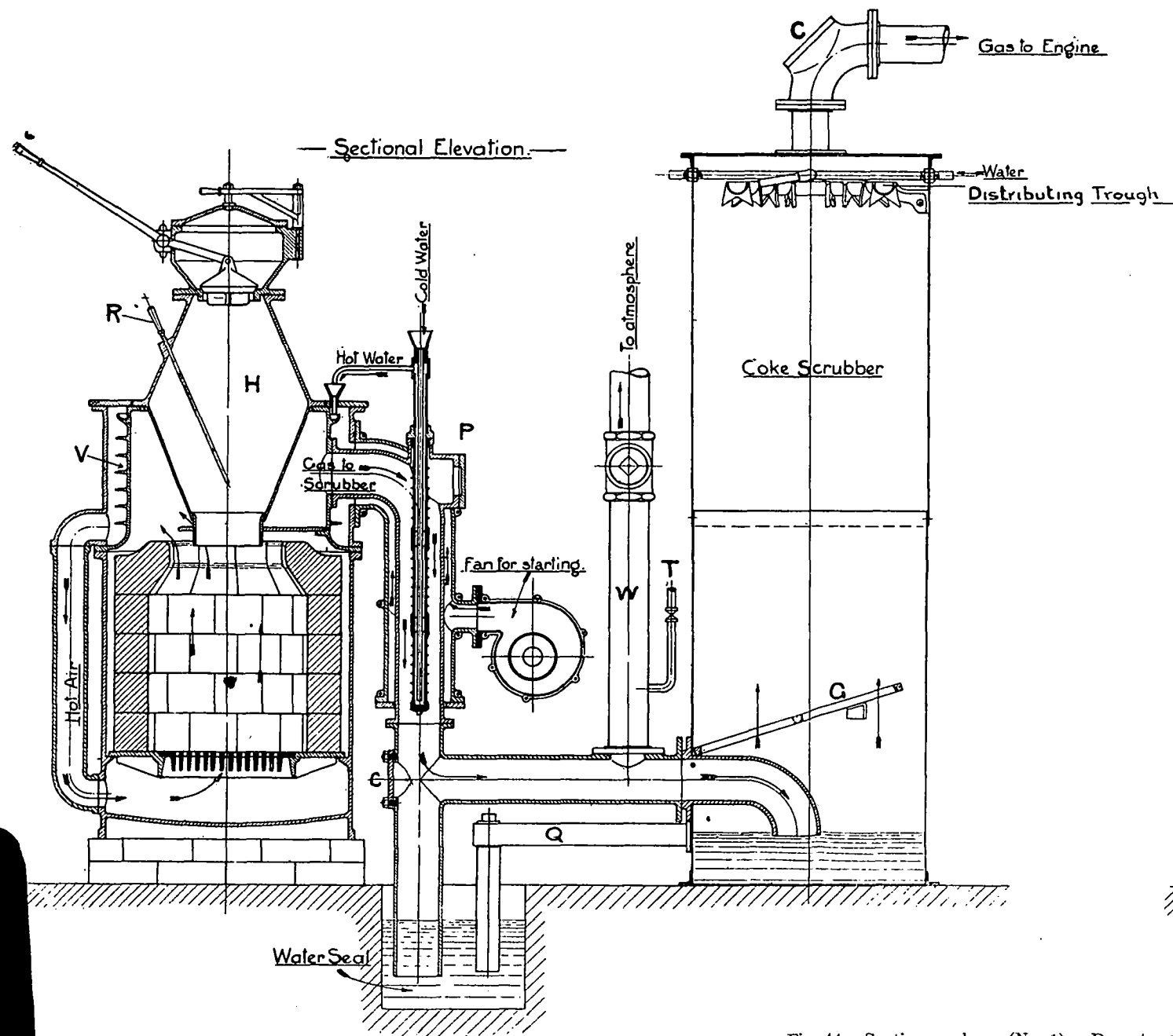
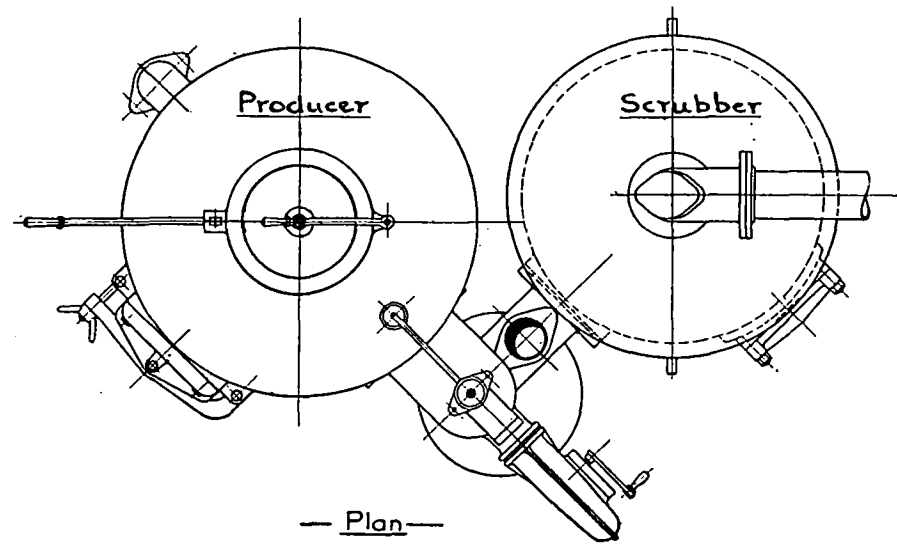

Fig. 44. Suction producer (No. 1). Department of Mechanical Engineering, McGill University.

Producers.—The final equipment of the plant thus included two producers: (a) a suction producer of the Dowson type, built by the National Gas Engine Co., Manchester, England, here referred to as No. 1, and suitable for burning anthracite or coke; and (b) a down-draft water-sealed producer designed by Professor Durley, built to his drawings by Alexander McKay of Montreal, and known as No. 4. These producers are shown in Figs. 44 and 45, and their leading dimensions are as follows:—

	No. 1.	No. 4.
Diameter of producer shell	2'-7"	3'-7"
Inside diameter of brick lining	2'-0½"	2'-6"
Area of fuel bed	2.3 sq. ft.	4 sq. ft.
Effective maximum possible depth of fuel bed	2'-3"	5'-6" with extension 4'-0" without "
Thickness of fire brick lining	4"	6"
Overall height of producer from floor to highest point	8'-0"	8'-8" with extension 7'-2" without "
Diameter of gas outlet pipe	5"	4"
Height and diameter of wet scrubber	8'-0" × 2'-10"	8'-0" × 2'-6¾"
Area of cross section of wet scrubber	5.9 sq. ft.	4.92 sq. ft.
Height and diameter of dry scrubber		8'-0" × 2'-9½"

The suction producer (No. 1), and its vaporizing apparatus as shown in detail in Fig. 44, is rather different in design from the types shown in Figs. 39 and 40. Referring to Fig. 44, the fuel hopper **H**, grate, and producer lining are somewhat similar to those already illustrated, while the wet scrubber **S** presents no special features. The necessary amount of water for the steam supply is dropped into a tube leading to the bottom of a heating pipe **P** having ribs on its outer surface, which is exposed to a current of warm gas leading to the scrubber. The upper part of the producer forms the vaporizer proper **V**, and the hot water from **P** trickles down from a circular trough over ribs past which the air from the inlet is also led. The air entering the producer is thus heated, and the water evaporated by the heat from the gases arising from the fuel bed. These are made to pass round the fuel hopper and inside the vaporizer casting on their way to the gas outlet. Air for starting is supplied by a hand fan; when running, the fan suction is closed and the air regulated by an adjustable inlet opening **A**. Cleaning doors **CC** are provided for the spaces above and below the grate, and at necessary points in the pipe system. The waste pipe **W** is opened to the atmosphere while starting up, and the combustible quality of the gas tried at the test pipe **T**. The coke in the scrubber is supported by the grating **G** and the scrubber water runs off through a water sealed pipe **Q**.

The down-draft producer (No. 4) is illustrated in Fig. 45, in which the wet or coke scrubber and connexions are not shown, as they were of the same construction as for producer No. 1. No vaporizer was used with No. 4 producer, nor was any provision made for preheating the air supply. It was

felt that with some of the coals tested trouble from tar was almost certain to arise in a vaporizer of the kinds shown in Figs. 39 or 44, and owing to the late date at which producer No. 4 was available, it was impossible to fit up a vaporizer, either of coiled pipe embedded in the brickwork, or of the water jacket type, such as has been found successful in bituminous producers of well known makes. It was also desired to obtain a measurement of the steam used in each test; for these and other reasons the steam supply was taken from a separate boiler and led into the top of the producer by a ring pipe just below the top plate, the amount supplied being estimated from pressure readings on the two sides of a calibrated orifice placed in the steam main. A separate additional ring of plate, together with the necessary firebricks for lining, was provided and could be placed on top of the producer, so that the depth of the fuel bed could be increased if found necessary. All the coals tested were, however, used successfully without having recourse to this additional section. The firebrick lining of the producer was carried on a cast iron bottom plate and was separated from the shell by about 1" of asbestos packing, and the shell and lining could be removed by the crane without disturbing any pipe joints. The fuel in the producer rested on a heap of ash around which sufficient space was left to permit the exit of the gases; the direct draft to the outlet pipe was screened by a firebrick baffle **B**, supported by brick and iron and protected by its position from damage by poking. The burnt fuel was held up by a rocking grate **G** at the bottom of a firebrick slope, the grate having cooling prongs dipping down into the water-seal **W**. The open top of the producer could be wholly or partly covered by a sliding plate, and three sight holes (available also for poking if necessary) were placed in the shell of the producer.

Plate XLVIII is a photograph of the down-draft producer No. 4 with its charging platform, the hood and piping for starting on up-draft, the atmospheric waste pipe **A**, the starting fan **F**, the wet scrubber **W**, and the 4" pipe **B** leading to the gas washer and exhauster.

For starting this producer the water in the seal at the bottom was lowered, and the open top connected by a portable pipe and hood with a small exhaust fan; the producer was then worked with up-draft until a satisfactory fuel bed was obtained, after which a short run on down-draft was usually necessary before starting the engine, the small fan or the exhauster being used for this purpose, and the gas discharged to the atmosphere. With some coals it was found that this procedure could be somewhat shortened by starting with coke, but when this was done it was necessary to run on down-draft for a longer time before steady test conditions were established.

Engine.—The engine installed was of the regular horizontal four cycle type, built by the National Gas Engine Co., Manchester, England, having a single cylinder 12" diameter \times 20" stroke, designed to run at 220 R.P.M. and capable at that speed of developing 40 B.H.P. with gas of 120 to 140 B. T.U. per cubic foot. Its construction and arrangement are shown in Fig. 46, and it was provided with a water cooled flywheel and rope brake, and with magneto ignition. It was fitted with indicator gear, including a special water

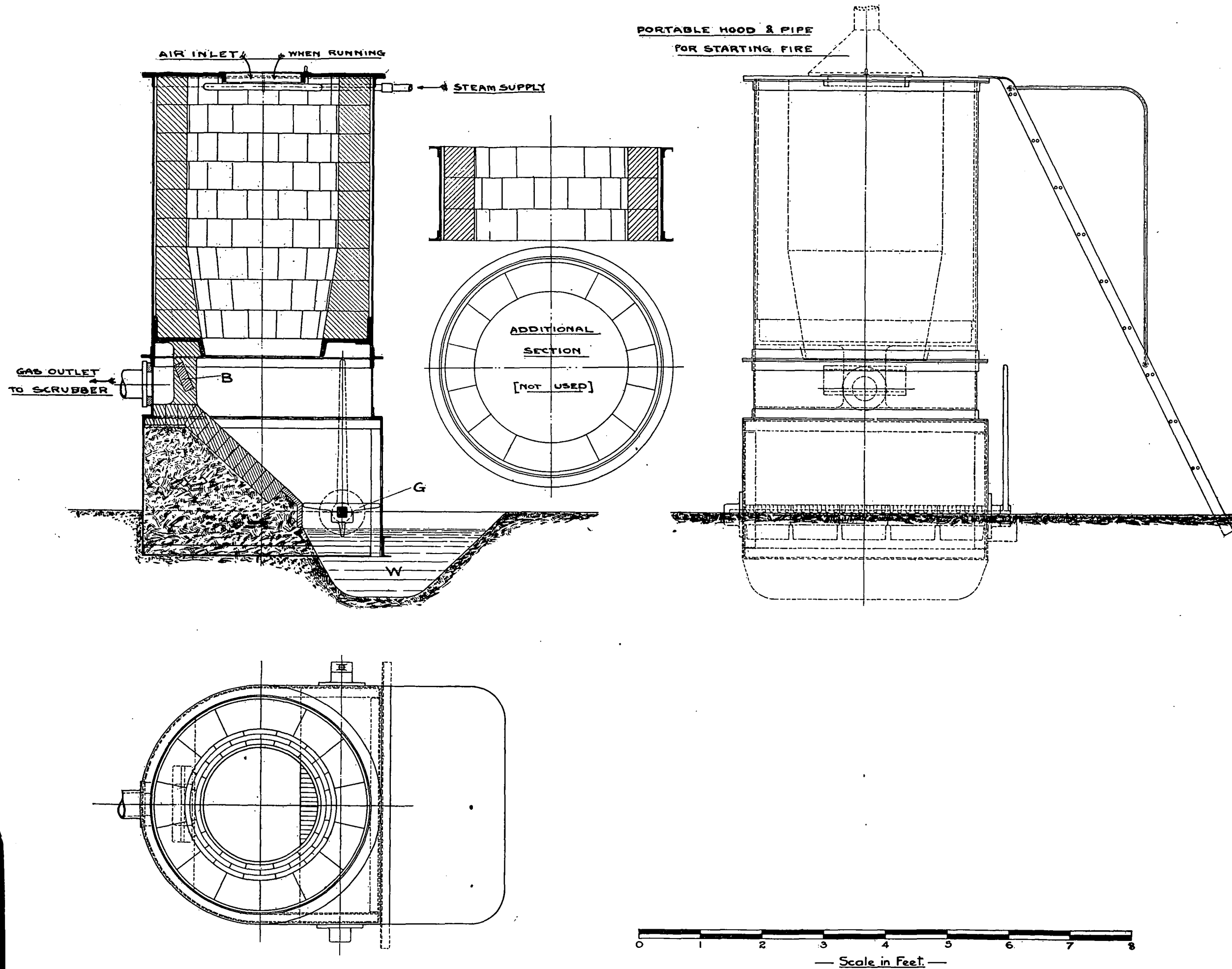
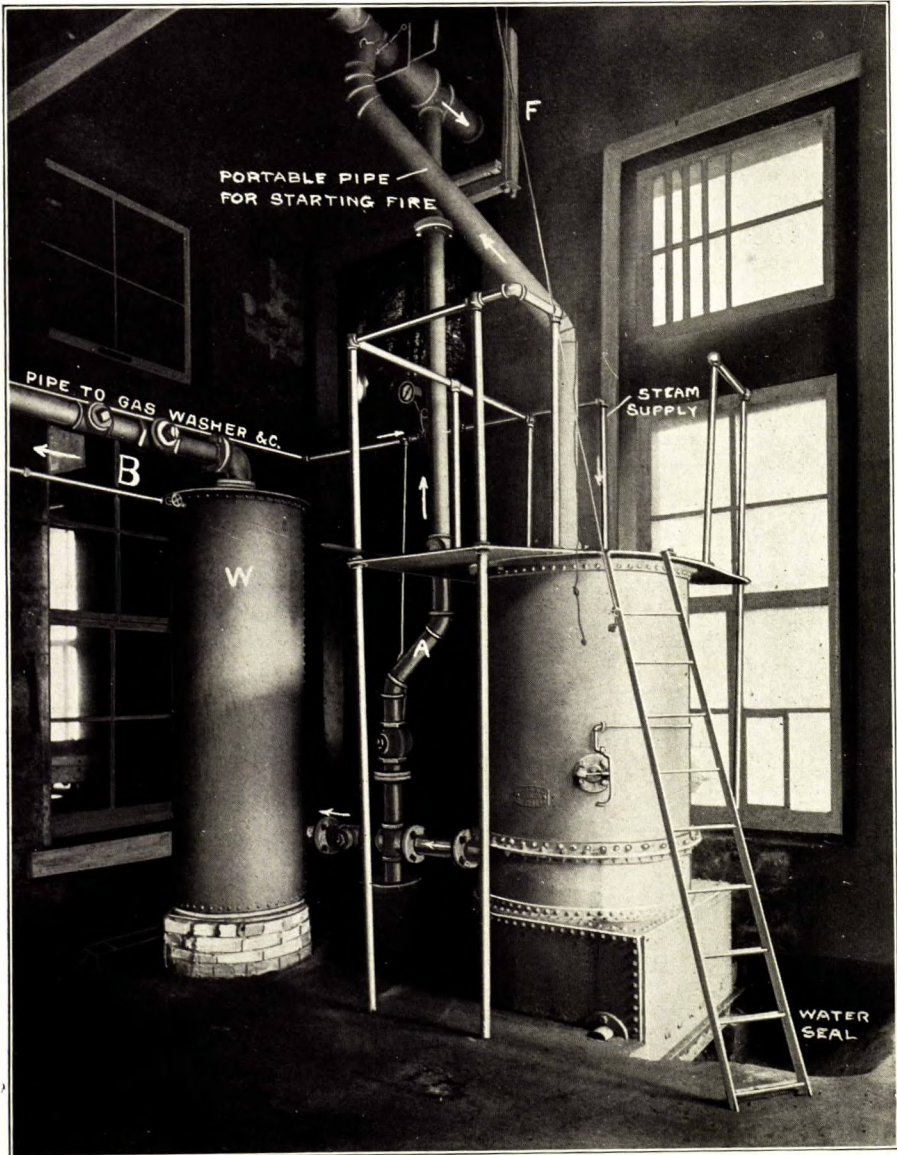

Fig. 45. Down-draft producer, No. 4. Department of Mechanical Engineering, McGill University.



Down-draft producer (No. 4). Department of Mechanical Engineering,
McGill University.

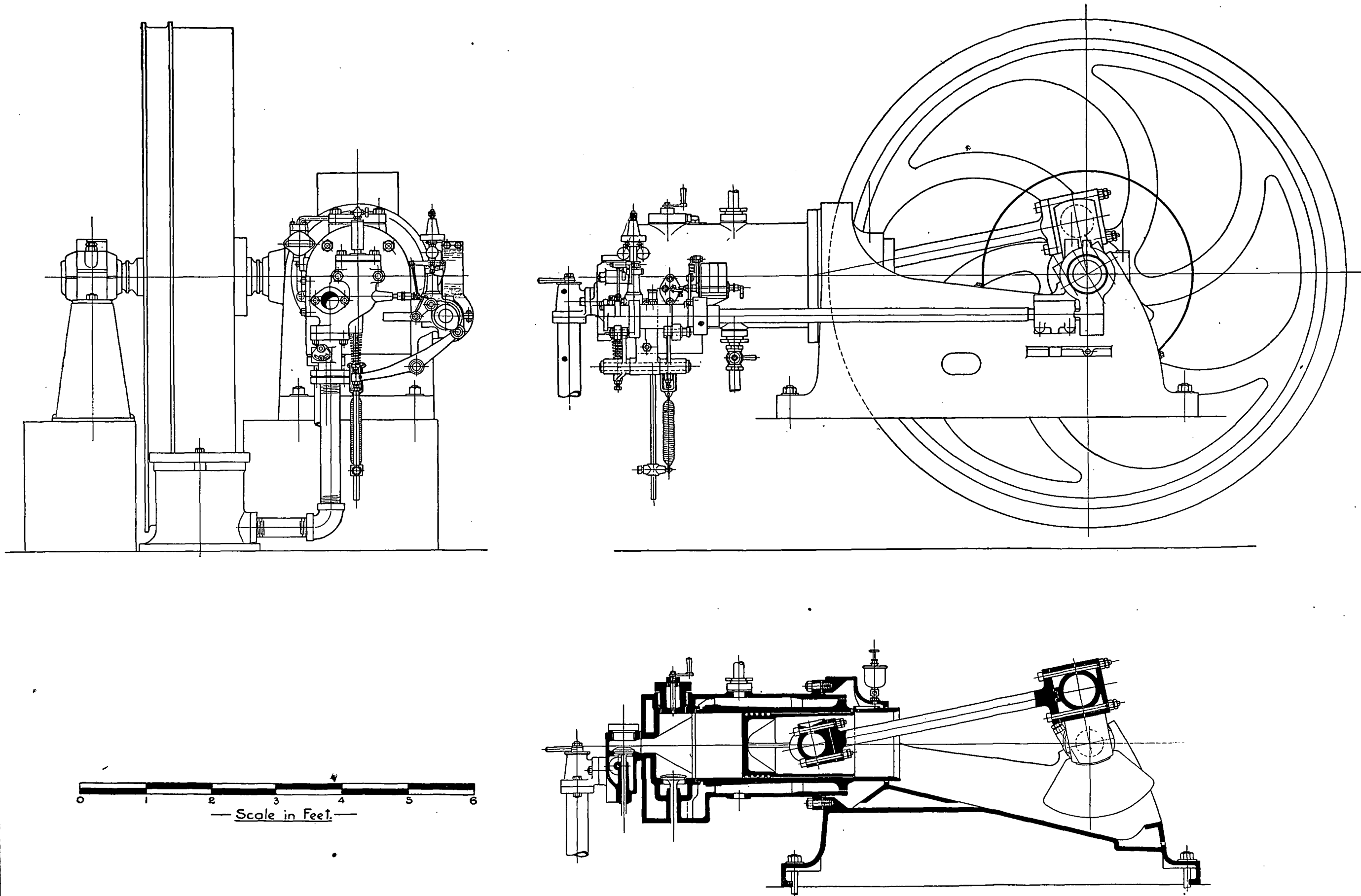

Fig. 46. Forty horse-power gas engine. Department of Mechanical Engineering, McGill University.

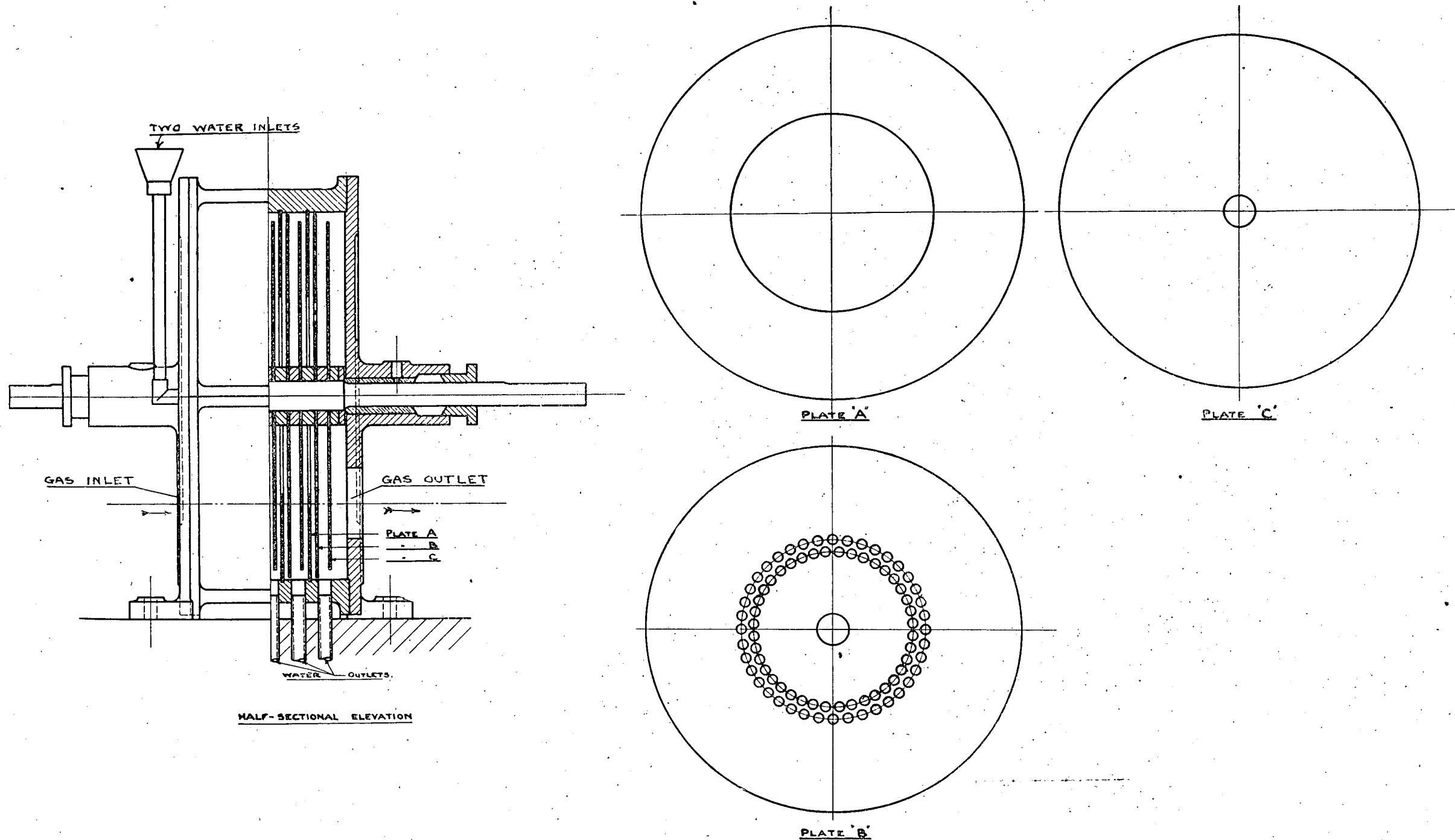

Fig. 47. Section through gas washer. Department of Mechanical Engineering, McGill University.

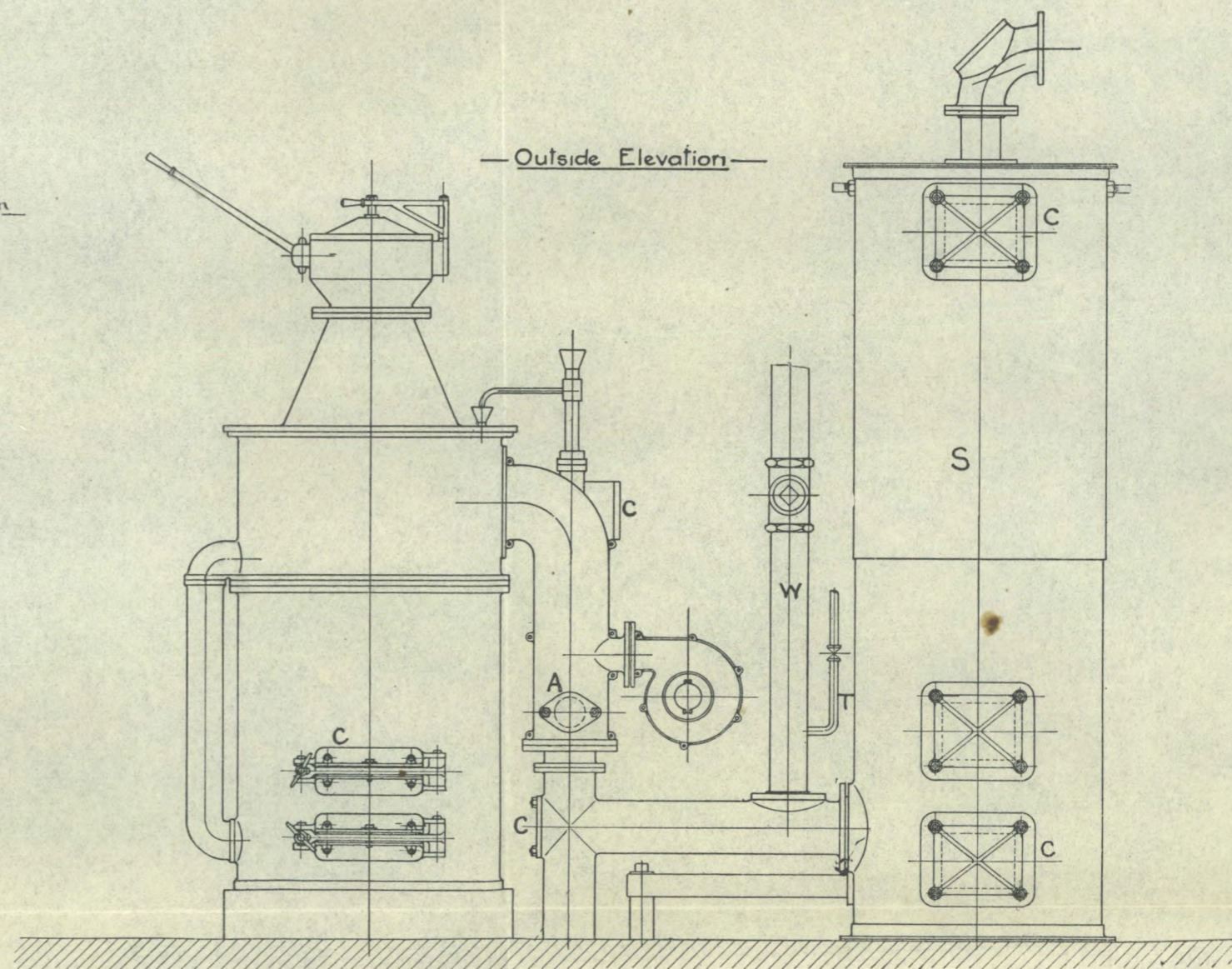
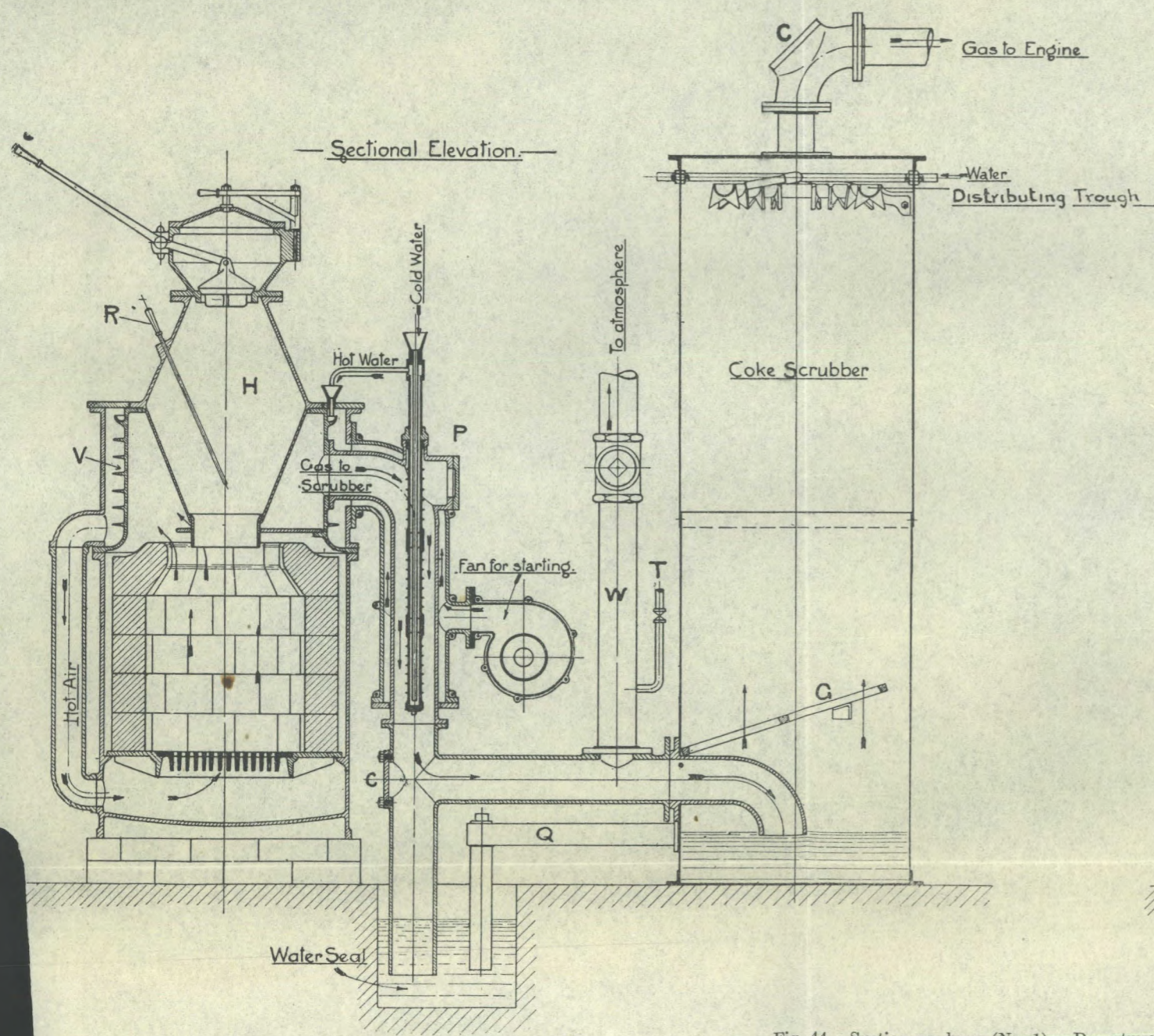
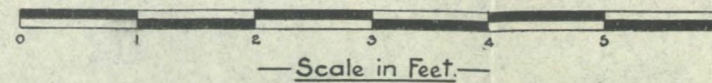
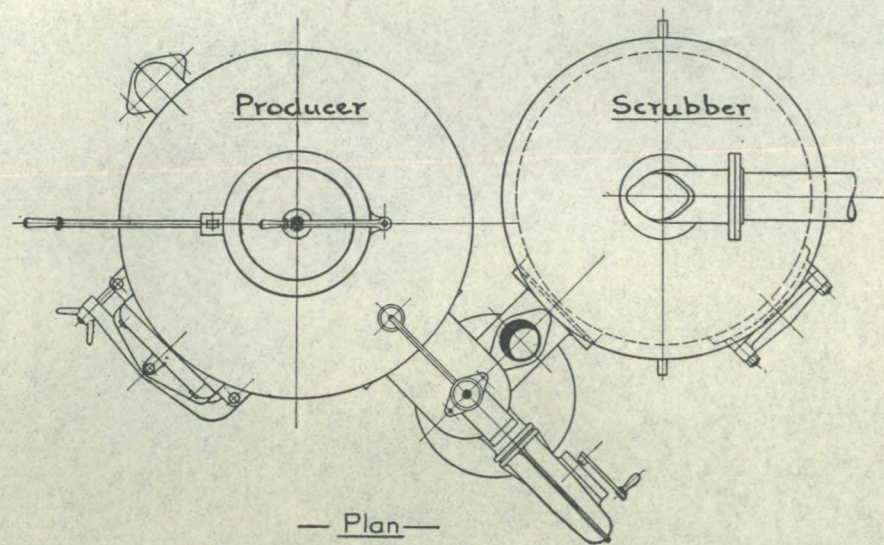

Fig. 44. Suction producer (No. 1). Department of Mechanical Engineering, McGill University.

cooled indicator connexion, and with means for weighing the jacket cooling water when required. Starting was effected by pumping up the compression space with explosive mixture and igniting this charge when the crank was placed a little past the dead centre and the piston was on the explosion stroke. The governor was of the hit and miss type, regulating speed by cutting out the gas charge entirely when in action.

Gas Holder.—A gas holder of 400 cubic feet capacity was provided. It was loaded so as to give a pressure of about $3\frac{1}{2}$ " of water, and was constructed of No. 17 sheet steel, stiffened with angles as required. An escape pipe to the atmosphere was arranged so that the rising of the gas holder bell above a certain point automatically opened a relief valve. In this way a sudden stoppage of the engine, or unexpected diminution in its rate of gas consumption, need not cause any interruption of the working of the producer. On leaving the gas holder the gas passed direct to the suction of the engine. It will be readily understood that the use of the gas holder was necessary in all cases where the gas had to be metered, and it was, indeed, used in all the official trials, although in several cases it would have been quite feasible to work with the suction of the engine only without the exhauster, had it not been for the necessity of measuring the gas.

Exhauster.—Gas was withdrawn from the producer through the scrubbers and gas washer by means of a Sturtevant gas exhauster (a machine of the Root blower type), and was delivered through the meter to the holder. The exhauster required little attention beyond occasional lubrication with coal oil. It was provided with a by-pass and relief valve connecting its discharge and suction, so that the amount of gas actually delivered to the gas holder could be easily adjusted.

Gas Meter.—The meter used was a No. 50 Westinghouse of the standard oil sealed type. It was calibrated periodically by the aid of the gas holder, and gave satisfactory service; its rated capacity was 8,500 cubic feet per hour.

Gas Washer.—A gas washer furnished by the National Gas Engine Co. was placed between the coke scrubber and the exhauster. Considerable trouble was experienced at first with this machine, the shaft and bearings being too light for hard service and the balance defective. Its construction is shown in Fig. 47. The gas was passed from end to end of a cylindrical casing in which rotated a horizontal shaft fitted with ten revolving plates of which five were perforated. Stationary plates (A) secured to the casing separated the successive pairs of rotating plates (B and C), and water was admitted at the inlet end of the casing. The tarry overflow water escaped through five outlet pipes at the bottom of the casing and passed into a wooden trough fitted with baffles, in which practically all of the tar washed out by the apparatus was collected. A similar tar box dealt with the tarry water from the coke scrubber.

GENERAL ARRANGEMENT OF PLANT AND ACCESSORIES

As will be seen from the general arrangement of the installation, as shown in Fig. 48, the piping system was so laid out that the gas could be taken either:

(a) from the suction producer (No. 1) through its coke scrubber direct to the engine; (b) from No. 1 producer through the scrubbers, gas washer, exhauster, meter, and gas holder to the engine or atmosphere; (c) from the down-draft producer (No. 4) through its coke scrubber direct to the engine; or (d) from No. 4 producer through the scrubbers, gas washer, exhauster, meter, and gas holder to the engine or atmosphere. Provision was also made on the pipe lines for by-passing any of the scrubbers, the gas washer, the meter, the gas holder, or the exhauster. Separate electric motors were provided for the gas washer and for the exhauster—a third small motor and exhausting fan were used for starting up No. 4 producer in the manner already described.

On leaving either producer, the gas was first passed through a coke scrubber, through which a stream of water was dripping, this water being then delivered to a settling box in which as much as possible of the tar carried off was collected. The gas then passed through the washer. After leaving the washer, the gas could be passed if necessary through a sawdust scrubber (a rectangular steel box provided with trays and packed with sawdust). On leaving this, the gas entered the exhauster and went through a dry scrubber filled with excelsior; it was then delivered to the meter and thence entered the gas holder. The gas main was 4" diameter throughout.

It will be noted that when working with the exhauster, the producer, wet scrubber, gas washer, and sawdust scrubber were under a pressure slightly less than atmospheric, the remainder of the apparatus being under a slight plenum.

The whole system was provided with water-seal boxes at intervals, so arranged as to act as tar drips and also as safety valves in the case of an excess of pressure in any portion of the gas piping. Cleaning doors and connexions for pressure gauges, gas sampling pipes, and thermometers were fitted wherever necessary.

Pressure gauges on the gas piping were of the ordinary U tube type, reading in inches of water, and were arranged so that the losses of pressure could be traced along the whole system, and any obstruction could thus be located.

The gas samples for analysis and calorimeter determinations were drawn from a sampling pipe connected to the 4" gas main just after leaving the dry scrubber, and a test flame pipe was also provided. The gas was, therefore, analysed after passing through the wet scrubber, gas washer, sawdust scrubber (when this was used), and dry scrubber.

The gas calorimeter was of the Boys' pattern, as described in Part IX of this volume.

The calorimeter as set up for use in the laboratory is seen in Plate XLIX. The calorimeter C, with its two thermometers, and water measuring vessels stands next to its gas meter M. On the left is the gas governor G, which maintains a steady and uniform flow of gas to the meter.

The gas analysis apparatus and methods are described in Part IX of this volume.

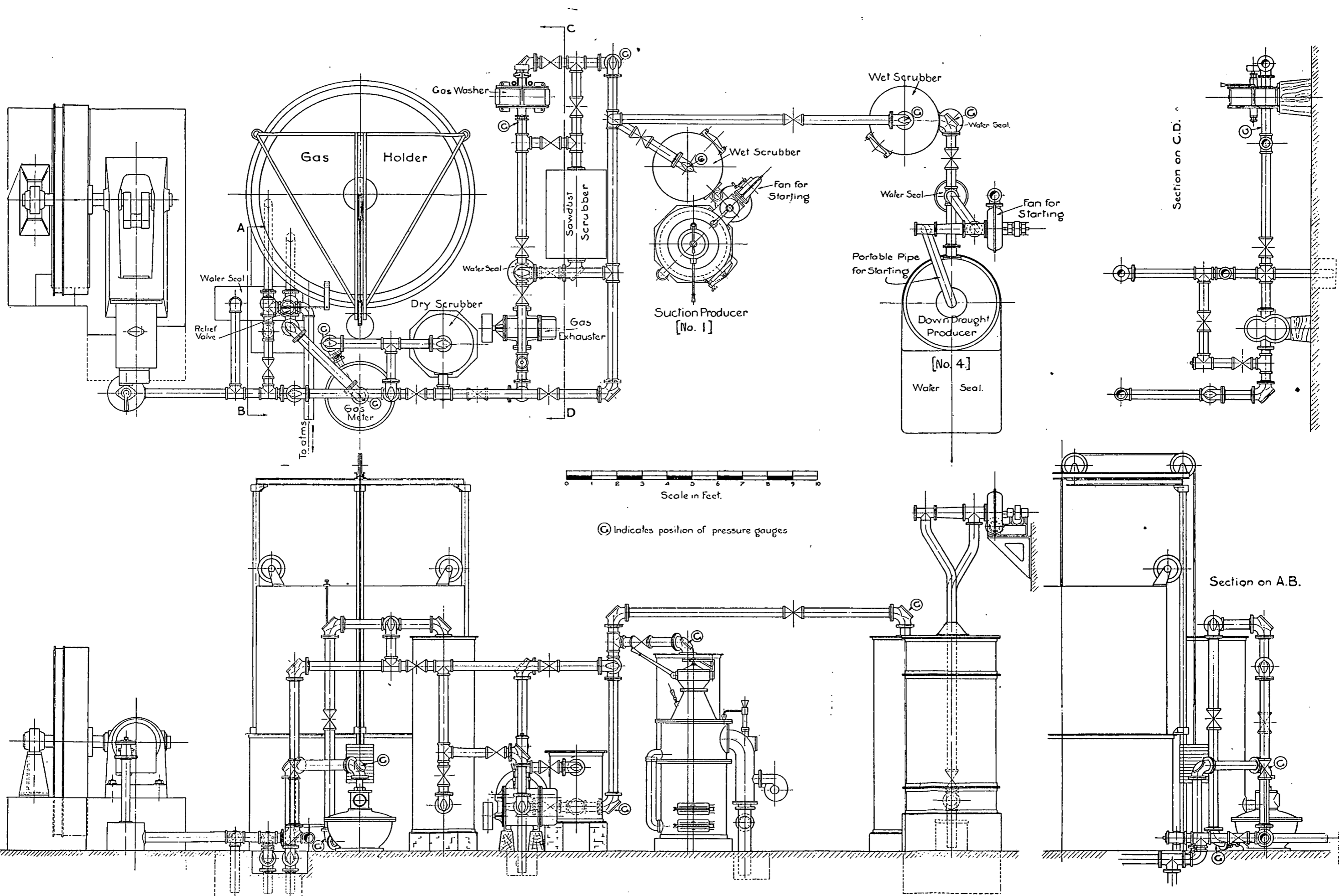

Fig. 48. General arrangement of experimental producer gas plant. Department of Mechanical Engineering, McGill University.

Boys' gas calorimeter as set up for producer tests. Department of Mechanical Engineering, McGill University.

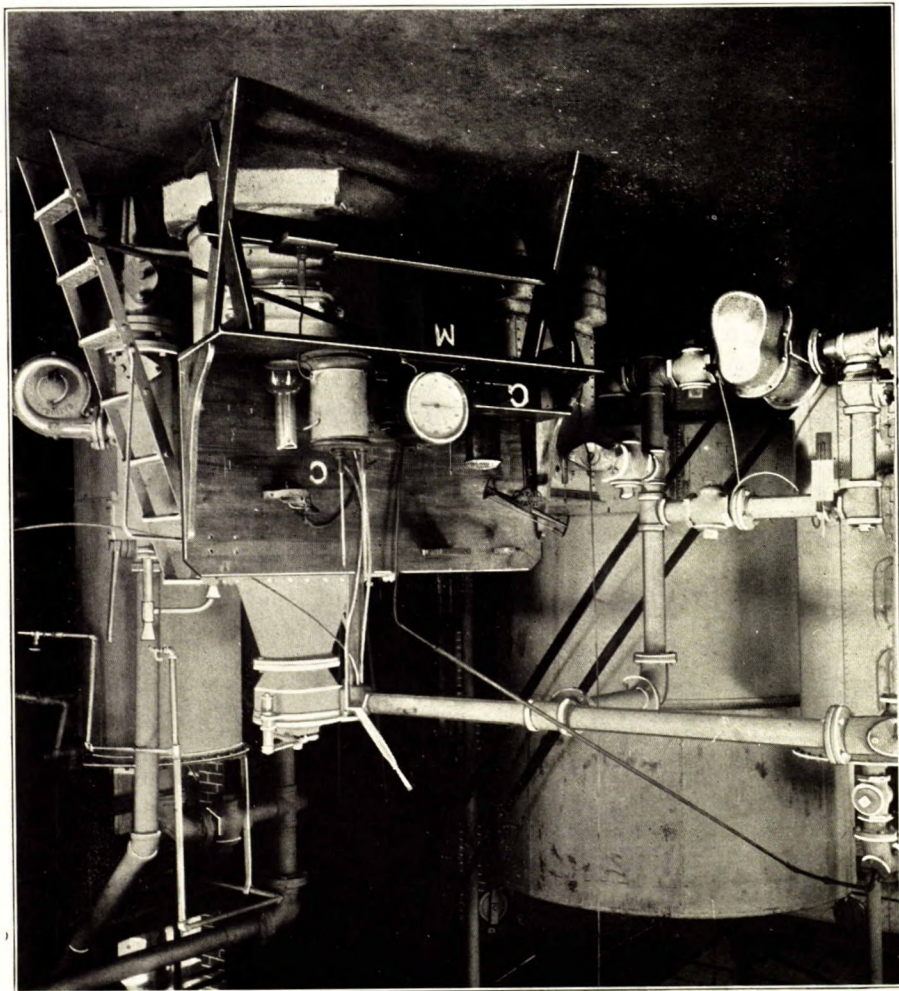

Plate XLIX.

Fairbanks standard scales were used for coal and ash weighing. Water used by the scrubbers and gas washer was metered.

Plate L shows the interior of the producer house, with the engine, brake, gas holder, and dry scrubber, the view being taken from the east end. The view from the west end is given in Plate LI. In this photograph will be seen the suction producer **P**, with its starting fan **F**, and wet scrubber **W**, the sawdust scrubber **S**, the exhauster **E** with its by-pass, the gas holder **G**, the dry scrubber **D**, and the gas meter **M**.

METHODS OF CONDUCTING TESTS AND MAKING MEASUREMENTS:
LOG AND CALCULATIONS FOR ONE TRIAL.

GENERAL PLAN OF TESTS.

As in the case of the boiler trials reported in Part VII, the object of the work was to compare the behaviour of, and the economic results obtained from, various samples of Canadian fuel; for this purpose only enough material was available for one run with each coal, including a reasonable preliminary period for adjusting the working conditions at the beginning of the test. In one or two cases, however, it was found possible to make longer tests or repeat tests, and these are duly recorded. In order to obtain more complete information as to the characteristics of each coal, it would have been desirable to make a series of three or four tests with each fuel, but the expense and time involved rendered such a course quite impossible. The length of continuous run necessary to obtain a close measurement of coal consumption in a gas producer test (under ordinary conditions as to rate of combustion) is at least 100 hours, if the result is to be correct within less than $2\frac{1}{2}$ per cent,¹ and a complete series of tests of this length could not be carried out with the staff or in the time assigned for the work. With the shorter tests actually made a high degree of accuracy in the measurement of coal consumption is not claimed, but the judgment on the performance of a coal in a gas producer depends not only on this quantity but also on such practical details as the amount of labour required in handling the coal and refuse, the uniformity or quality of the gas produced, and the trouble experienced with tar or dirt, points on which a 24 hour run gives sufficient information. The behaviour of each coal in these respects was carefully observed.

It may be noted that the preliminary period above mentioned was found in practice to be too short, and it is, therefore, certain that many of the coals tested could have been utilized to better advantage than was actually the case. For example, three of the samples were large enough to make repeat runs, under somewhat different conditions from those obtaining in the original trials; with two of these samples the second test gave much better results than were reached in the original tests; in the third case (a lignite) the fuel had apparently altered by keeping.

In the circumstances, it was decided that in each case a continuous run of 24 hours should be aimed at, with a preliminary period of from 4 to 5

¹ See p. 68.

hours, during which the best available working conditions for the fuel under test should, if possible, be found; the proper depth of fuel bed and amount of steam to be supplied being determined during this time and before the commencement of the trial proper. In one case, by mixing the remainders from two samples of somewhat similar coal, it was found possible to make a run of 100 working hours, working 10 hours per day and banking the producer at night. This test was made chiefly to demonstrate the capacity of the installation for work under conditions similar to those of commercial practice, and as a check on other tests in the same group.

The unavoidable delay in the installation of a satisfactory producer for bituminous coals left so short a time available for the whole series of tests, that two had to be made each week during the period from November 1908 to March 1909, and this programme was duly carried out, with the exception of an intermission at Christmas. It was thought desirable to clean out the producer completely after finishing the work with each coal, in order that information might be obtained not only from the analysis of the refuse withdrawn during each test, but also from the composition of the fuel bed as drawn when each trial was completed. As will be seen, the results of these analyses were of considerable utility, and the adoption of this system (as compared with the method of continuous running or banking fires between the tests) rendered it certain that no material from previous tests remained in the producer, and that each fuel received exactly the same treatment so far as starting and stopping the tests were concerned. The actual running period for each coal (except where otherwise stated) was about 30 hours, during about 26 to 28 hours of which the engine was working as nearly as possible at its intended load.

During all tests it was desired to produce gas which would give 30 B.H.P. at the engine, but owing to difficulty in working and the necessity for the use of large amounts of steam some of the coals yielded a poor gas and a lower output. As different fuels gave gases of different calorific values, this involved working at somewhat different rates of combustion, as in the case of the boiler tests.

*Duties of Staff.*¹—The available operating and observing staff was not sufficiently numerous to work in two complete shifts. It was, however, possible to arrange that the men whose duties were most laborious should be relieved at least once during each thirty hour run. Four men were on duty at a time; their work was as follows:—

Operator No. 1. (In charge of operation of plant.) Attended to working of engine, producer, and auxiliary machinery, took counter readings, directed charging fuel into, and removal of ashes from, the producer.

Operator No. 2. (Fireman.) Charged coal into producer, removed ashes, worked fire in producer, collected tar for weighing.

Observer No. 1. Weighed coal, observed pressures, temperatures, and load on brake, took meter readings and indicator diagrams.

Observer No. 2. Worked gas calorimeter and sampled gas and fuel for analysis.

¹ See Vol. I, p. 4 and 5.

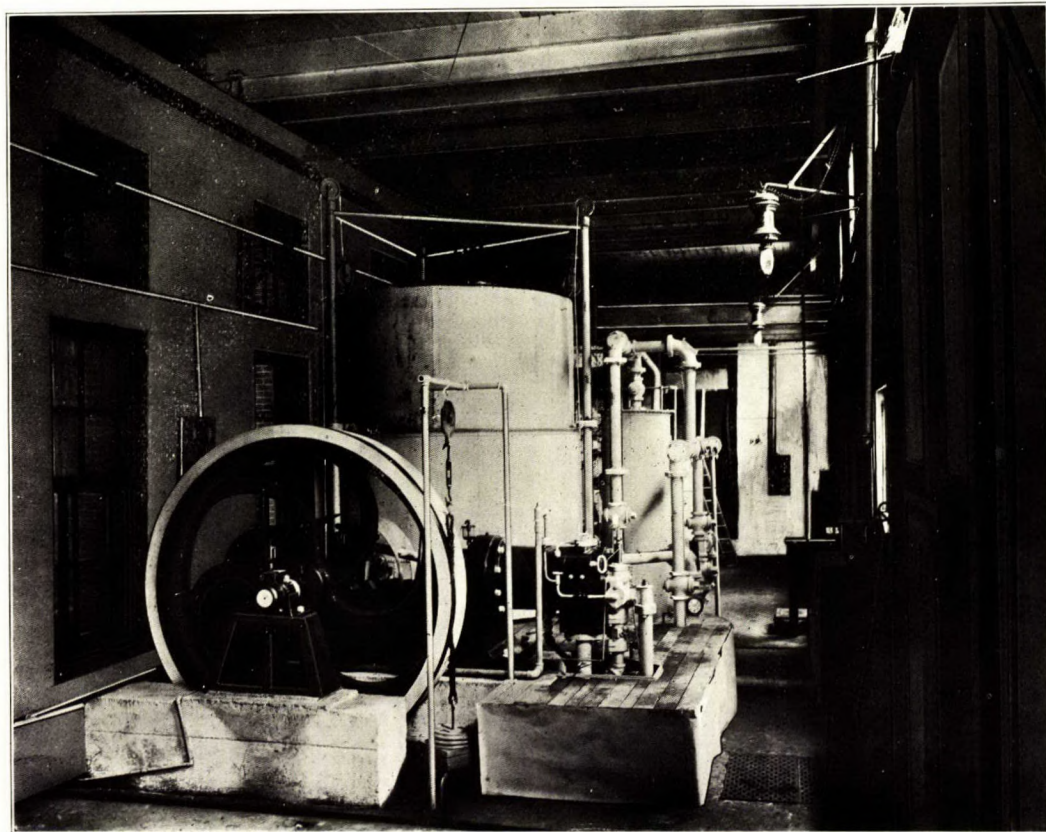

Interior of gas producer laboratory, looking west. Department of Mechanical Engineering,
McGill University.

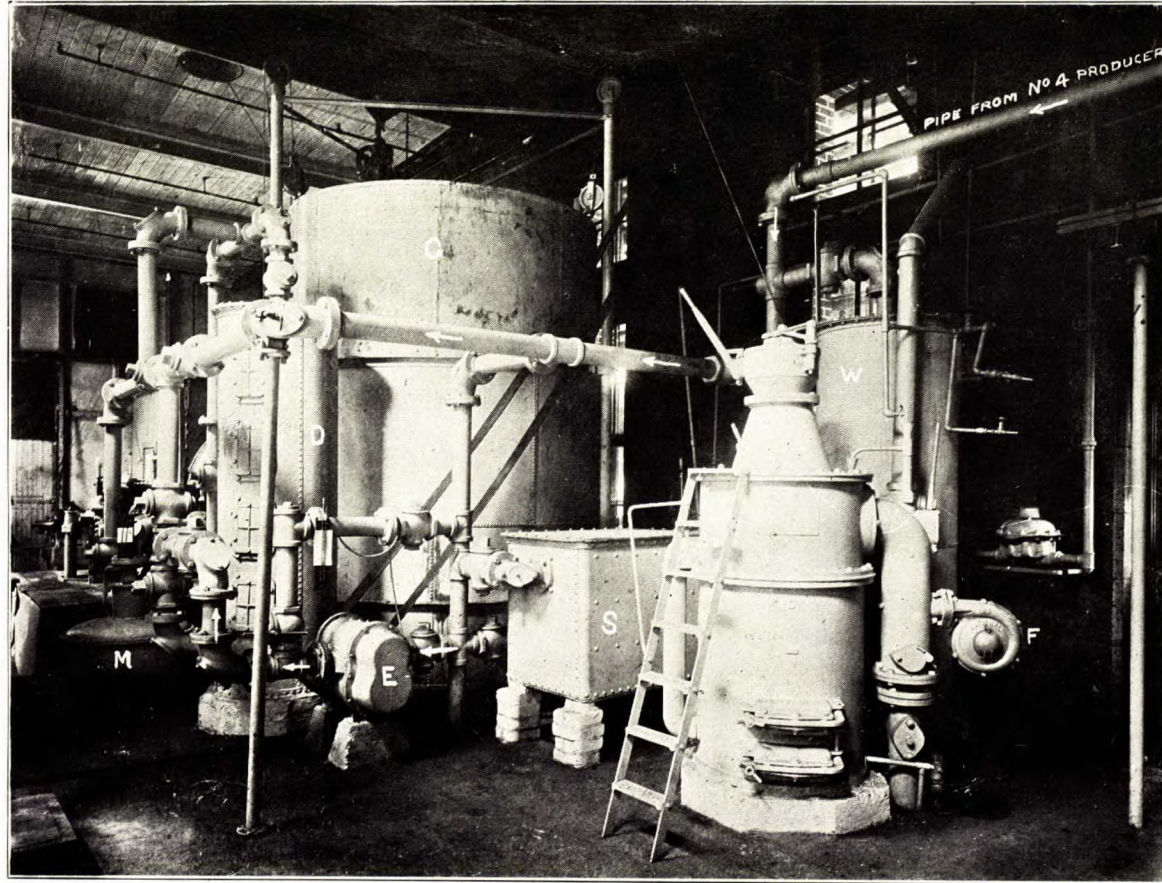

Interior of gas producer laboratory, looking east. Department of Mechanical Engineering, McGill University.

These observers interchanged duties occasionally, as was found convenient.

In addition to the above duties, one member of the chemical staff was continuously engaged in making analyses of gas, fuel, and refuse samples. Observations were taken at 30 minute intervals.

General Precautions.—The producer and tar boxes were cleaned out after each trial to ensure that no clinker, tar, or refuse from one trial should be charged to the next. All pipes and joints were tested for leaks periodically. No trial was begun until the engine had been carrying its load satisfactorily for a sufficient period to ensure good working conditions in the fuel bed. The engine valves were not cleaned before each trial, but were taken out when attention was needed, usually after about 60 to 120 hours running. The main gas meter and the calorimeter gas meter were calibrated at intervals of about a week. Coke in scrubbers was renewed once during the series. Scales were tested with standard weights before and after the series.

METHOD OF HANDLING FUEL AND STARTING AND STOPPING TRIALS.

The producer having been cleaned, the space above the grate was filled up to the level of the bottom of the gas outlet (see Fig. 45) with clean broken brick, free from dust, and of such size that it would pass through the grate when shaken; about 800 pounds were usually required for this purpose, the amount depending on the size and dryness of the pieces. The fire was then started with about 50 pounds of wood and 100 to 150 pounds of screened gas coke, air being admitted from the grate and the products of combustion exhausted by the small fan (Fig. 47). The coal to be tested was then charged until the proper depth of fuel bed was reached and the fire was well alight, when the producer was put on down-draft. As soon as good and uniform gas was obtained at the producer, usually about one to two hours after lighting up, the exhauster was started and the small exhausting fan stopped, the gas being then discharged to the gas holder and thence to the atmosphere. The engine was started and load put on at a convenient time thereafter, and meanwhile the steam supply was adjusted in accordance with preliminary calorimeter determinations. After running thus for a period of from three to five hours, and when constant conditions were obtained, the trial was commenced; at the same time all ash and refuse were cleaned out from the water-seal and any broken brick and ashes brought down by shaking the grate or poking were removed and put aside. Owing to the arrangement of the producer bottom, and to the necessity (with some coals) of poking unequally in different parts of the producer bed, it was usually found that some of the refuse formed during the early part of the run would come through the grate before all the brick had passed. Some of the brick would then come through during the trial. The carbonaceous refuse (excluding brick) coming through during the test was put aside, weighed, and sampled. During the trial weighed amounts of coal were added to the producer and corresponding amounts of refuse removed at as regular intervals as possible, but it was found that with a coal which gave any trouble from clinker or hanging of the fuel bed, the

regular rate of charging coal had often to be departed from to make up for the effect of poking. The same circumstances rendered it impossible to maintain an absolutely constant depth of fuel, and in many trials the depth varied some inches; it was, however, brought back to the end of the trial as nearly as possible to the original depth. Fortunately, the open top producer enabled a very close measurement of the fuel level to be made.

At the conclusion of each test the whole contents of the producer were removed as quickly as possible through the water-seal. An endeavour was made at first to keep separate the portion below the gas outlet, in order to estimate the combustible value therein, but this was found to be impossible and the attempt was abandoned. The contents of the producer, freed from any brick by hand picking, were weighed wet, a known proportion, say 100 pounds, was then taken, dried, weighed again, and sampled for analysis. The same treatment was accorded to the refuse withdrawn during the test. It may be noted that in the first three trials of the series (Nos. 8, 9, and 10) the refuse withdrawn during the trial was inadvertently mixed with the producer contents; for these trials, therefore, it is not possible to give the composition of the refuse formed during the test (See Table XXXIII, Part VIII.)

The coal for each trial was delivered to the gas producer laboratory by the staff in charge of the coal sampling, each bag being tagged with the serial number of the coal (See Column 2, Table XXXIII.) All coal for the gas producer tests was freed from dust before delivery to the producer laboratory by passing over a $\frac{1}{2}$ " screen, but beyond this received no special treatment. Coal samples during the trial were taken from each bag, for check analyses, and especially for moisture determinations.

TEMPERATURES, PRESSURES, AND OTHER DETAILS OF TEST.

Steam Supply.—The steam supply was taken from a well lagged pipe carrying about 80 pounds pressure per square inch, and after going through a separator, reducing valve, and gauging orifice, was admitted as required to the ring inlet pipe surrounding the opening at the top of No. 4 producer. The pressure gauges at the gauging orifice were tested periodically, and the gauging apparatus was calibrated by allowing it to discharge under as nearly as possible working conditions into a surface condenser from which the discharge was weighed. The amount of steam passed by the orifice with any given readings of the two pressure gauges was thus determined.

Temperatures.—The temperature of the gas leaving the producer was taken by a thermo-junction electrical thermometer, the indications of which were used as a guide in operating the producer. Gas temperatures at other points were taken with standard mercurial thermometers, as was also the temperature of the warm jacket water of the engine, the latter serving as general indication of the satisfactory and uniform operation of the engine.

Pressures.—The differences of pressure existing between the atmosphere and the interior of the gas main were taken by means of ordinary U water gauges at the following points, and, during regular running, had approximately the following values:—

Pressure leaving gas meter and entering gas . . .
holder 3" to 3½" of water.

Pressure entering gas meter.	4 $\frac{1}{4}$ to 4 $\frac{3}{4}$	ins. of water.
Pressure leaving exhauster.	4 $\frac{1}{2}$ to 5	“ “
Suction entering exhauster.	6 to 7	“ “
Suction leaving gas washer.	5 $\frac{1}{4}$ to 6 $\frac{1}{4}$	“ “
Suction entering gas washer.	3 $\frac{1}{2}$ to 4	“ “
Suction leaving wet scrubber.	3 $\frac{1}{4}$ to 3 $\frac{3}{4}$	“ “
Suction leaving producer.	1 $\frac{1}{4}$ to 1 $\frac{3}{4}$	“ “

The resistance of the fuel bed was thus usually from 1" to 2" of water, that of the wet scrubber about 2", that of the gas washer about 2", and that of the meter about 1 $\frac{1}{4}$ "; the exhauster took about 2 $\frac{1}{2}$ H.P. and worked against a total difference of from 10" to 14", depending on the conditions of the pipes, passages, scrubber, and producer, and the volume of gas dealt with.

Gas Meter.—As already stated, this was of the standard Westinghouse oil-sealed type; it was calibrated after every four trials by comparing its indications with those shown by the rise of the gas holder whose capacity had been carefully determined. The error in every case was found to be insignificant.

Gas Calorimeter.—This was of the Boys' type (see Plate XLIX, and Part IX), and was calibrated by the chemical staff before being set up in the laboratory. During the progress of the tests, in order to guard against errors due to the effect of tar and dirt on the pressure regulator and calorimeter gas meter, these were cleaned frequently and the meter checked by passing through it a known volume of air from an aspirator bottle.

Fuel, Refuse, and Gas Analysis.—The methods of chemical analysis and the apparatus employed are fully discussed in Part IX, and, therefore, need not be dealt with here.

Gas Sampling.—Gas samples were collected over water in bottles holding about 300 c.c. These were sealed with paraffin wax, labelled, and sent to the chemical laboratory for analysis.

Collection and Measurement of Tar.—The series of tests commenced with the western lignites, to which the down-draft producer seemed well suited, practically no tar being found in the gas as it left the producer. With these coals, in fact, the scrubber seemed to take little or no tar out of the gas, and the same remark applies to the gas washer, and in some trials with these coals the latter apparatus was not used at all. When bituminous coals began to be used, however, it was found that while the scrubber and tar washer were certainly cleaning the gas, but little tar was found in the water seals into which their discharges flowed. Steps were taken, at once, therefore, to devise a settling box in which the tar could be more completely separated from the washing water, and after some experiments satisfactory tar boxes were made and placed in service in 1909. In trials made before that date, therefore, figures as to tar are not so complete as in the later tests. The use of steam in the pipes was found a considerable aid in the collection of tar after a test, and in some cases with very sticky tar it was necessary to by-pass the gas washer and clean it out with a steam jet before starting it again.

Measurement of Water Used.—The water used by the wet scrubber was metered, and taken from the city mains. That used by the gas washer was estimated from the results of a series of special experiments. No particular attempt was made to economize in the use of water.

Engine Measurements.—The engine brake horse-power was measured by a rope brake (seen in Plate L) in which a dead weight was kept floating between stops. The load on the slack side of the rope was measured by a spring balance. Revolutions and ignitions were taken by two Crosby counters connected to the valve shaft and the governor gear respectively, and indicator diagrams were taken every hour (chiefly as a check on the satisfactory working of the engine) by a Crosby gas engine indicator. It must not be forgotten that the tests were really on the gas producer, the engine being run to demonstrate the suitability of the gas for power purposes rather than as a part of the coal test. In some of the earlier trials when working with free burning coals, and especially if gas of low calorific value resulted, it was found difficult to regulate the working of the producer so as to avoid making rather more gas than the engine could take at its regular speed, even when firing every cycle. In such a case, the whole of the gas produced was, of course, metered, but a small amount passed to the atmosphere through the relief valve instead of to the engine. Allowance was made for this in the calculations for B.H.P., by taking the B.H.P. as that which would have been maintained had all the gas metered been sent to the engine, the engine consumption per B.H.P. per hour with approximately the same load being known from a period during which all gas metered had passed through the engine. In later trials, when the staff were more familiar with the operation of the producer, this trouble did not arise.

DETERMINATION OF RATE OF FUEL CONSUMPTION.

This quantity, as distinguished from the rate at which coal is *charged* into the producer, is perhaps the most difficult to establish accurately, and is certainly the most important in a gas producer test.¹ The various possible methods of determining the actual rate of fuel consumption have already been discussed. It was hoped that in working out the results of the trials here reported, the fuel actually consumed could have been closely estimated from the coal charged, by the aid of data derived from the chemical analyses of the gas produced, the refuse removed during the trial, and the contents of the producer at the conclusion of the trial. This was felt to be especially desirable, because the length of each trial was limited to 24 hours, and any difference in condition of fuel bed, as between the beginning and end of a trial, would, therefore, have a comparatively large influence on the apparent value of the producer efficiency.

On proceeding to work out the trials in this manner, it was found that in certain of the trials somewhat inconsistent results were obtained, although in most cases a fair agreement was found with the known amounts of carbon dealt with and the fuel bed conditions which probably existed. It was, there-

¹ See p. 67.

fore, considered better to state only the coal actually charged, using the analyses of the refuse and producer contents simply as an indication of the similarity or otherwise of fuel bed conditions at the beginning and end of the trial. This has been done in discussing the trial results in subsequent pages.

DETAILED RESULTS OF PRODUCER TRIAL NO. 32.

In order to exemplify the methods adopted and the observations taken during the gas producer tests, the log and observation sheets for one trial (No. 32) are annexed, together with the resulting calculations worked out in detail. This test was made on a sample of bituminous coal from Cape Breton, and is here given as a fairly representative one, and as being made with the same coal as that for which complete calculations are given in the report of the boiler tests.

Similar detailed information as to the logs and observation sheets of the whole series of trials is given in Volume V of this report.

Log of Events.

Trial of No. 4 producer with No. 36 coal.
Date March 8 and 9, 1909. Trial number 32.
Observations of general conditions.
Observers: J. S. Cameron and G. Killam.

General Notes.

Barometer at beginning	29.83 inches.
“ “ 8.20 p.m.	29.88 “
“ “ end	29.97 “
mean	29.89 “
Water meter 9 a.m.	96877 imp. gallons.
Water meter 8 a.m.	99765 imp. gallons.
Difference	2888 imp. gallons in 23 hours
Brick in producer base.935 lbs.
Average level of coal surface below top plate of producer, 17".	
2.40 a.m. March 8	Fire lighted. Charged 5 lbs. shavings, 40 lbs. wood, 120 lbs. coke.
3.20 “ “	Down draft. Charged 131 lbs. coke.
4.30 “ “	120 lbs. coke.
5.40 “ “	100 lbs. coal.
7.00 “ “	100 lbs. coal.
8.15 “ “	Started engine. Full load applied.
8.20 “ “	Trial commenced.
11.30 “ “	Cleaned regulator of calorimeter and steamed gas washer.
4.00 p.m.	“ Steamed gas washer.
5.20 “ “	Gas washer running hot. Stopped and passed gas through dry scrubber.

- 6.20 p.m. March 8 Started gas washer, but trouble continued so stopped it again for remainder of trial.
- 8.20 a.m. March 9 Trial finished. Drew fire. Engine valves in good order except for a little soot. Heavy suction during early morning due to dirt in long pipe.

Summary of Observations.

Date, March 8 and 9, 1909. Producer No. 4 at McGill University.

Time of lighting up 2.40 a.m. Trial commenced 8.20 a.m. Ended 8.20 a.m.

Duration of trial 24 hours. Kind of fuel: coal No. 36.

Observers and staff during trial: Killam, Cameron, Gardiner.

Computers: Killam, Cameron, Ford.

Chemists: Stansfield, Nicolls, Campbell.

Fuel—

- | | | |
|----|--|--------------|
| 1. | Total coal charged during trial. | lbs. 1450 |
| 2. | Moisture in coal as charged. | % 2.4 |
| 3. | Calorific value of coal as charged, per lb. | B.T.U. 13520 |
| 4. | Calorific value of dry coal per lb. | B.T.U. 13860 |
| 5. | Proximate analysis of coal as charged (by weight): fixed carbon 57.6; volatile matter 35.0; ash 5.0; moisture 2.4% | |
| 6. | Combustible in dry refuse removed during trial: fixed carbon 38.1; volatile matter 4.7% | |
| 7. | Average depth of fuel bed (measured from centre of gas outlet). | ins. 43 |

Gas—

- | | | |
|------|--|----------------|
| 8. | Total gas produced during trial (from meter readings) | cub. ft. 79240 |
| 9. | Average temperature of gas leaving producer | °F. 783 |
| 10. | Average temperature of gas at meter. | °F. 66 |
| 11. | Average temperature of air in producer house | °F. 64 |
| 12a. | Average higher calorific value of gas per cub. ft. by calorimeter (as observed). | B.T.U. 112.8 |
| 12b. | Average higher calorific value of gas per cub. ft. by calorimeter (gas dry at 60° and 14.7 lbs. per sq. in.) | B.T.U. 115.7 |
| 13. | Average lower calorific value of gas per cub. ft. by calorimeter (gas dry at 60° and 14.7 lbs. per sq. in.) | B.T.U. 106.5 |

14.	Average barometric pressure	lb. sq. in. 14.65
15.	Average suction at producer.	ins. 0.98
16.	Average suction at exhauster.	ins. 9.10
17.	Average pressure of gas at meter.	ins. 4.62

Steam, Water, Etc.—

18.	Total steam used in producer during trial.	lbs. 2160
19.	Total water used in scrubber and gas washer. . .	lbs. 35910
20.	Total tar extracted in scrubber and gas washer .	lbs. 94
21.	Average power required to drive exhauster	H.P. 2.5
22.	Average power required to drive gas washer . . .	H.P. 1.5

Engine—

23.	Total revolutions during trial (from counter) . .	320198
24.	Total explosions during trial (from counter) . . .	145794
25.	Average effective load on brake.	lbs. 155.5
26.	Effective radius of brake wheel	ft. 3.836
27.	Average mean effective pressure from indicator diagrams	lbs. sq. ins. 69.6

28. NOTES.—Fire poked at: 8.20, 8.50, 9.20, 9.40, 9.55, 10.50, 11.15, 11.55 a.m., 12.05, 12.45, 1.05, 1.45, 2.40, 3.50, 4.50, 5.05, 7.10, 8.30, 10.50, 11.40 p.m., 2.10, 4.40, 5.40, 6.25 a.m.

Refuse removed at: 8.50, 9.55 a.m., 12.45, 2.45, 5.25, 8.30 p.m., 2.30, 3.50, 5.40 a.m.

Behaviour of coal: required considerable attention—cakes.

Average time between poking: one hour.

Clinker: little trouble. Tar: a good deal.

State of engine valves at end of trial: good condition except for a little soot.

Valves last cleaned: February 23, 1909.

29. ANALYSIS OF DRY COAL.

Hydrogen	5.0
Carbon	76.7
Nitrogen	
Oxygen.	
Sulphur	2.4
Total carbon con- tained by dry coal 1085 lbs.	

30. ANALYSIS OF GAS BY VOLUME.

Carbon dioxide	10.9
Oxygen.	0.5
Carbon monoxide	11.4
Hydrogen.	11.4
Methane	3.2
Ethylene.	0.1
Nitrogen.	62.5

Remarks—

A satisfactory trial considering the nature of the coal. A rather deep fuel bed was maintained which destroyed a good deal of the tar. This coal gives some trouble in the producer but the gas was uniform enough to avoid any engine trouble.

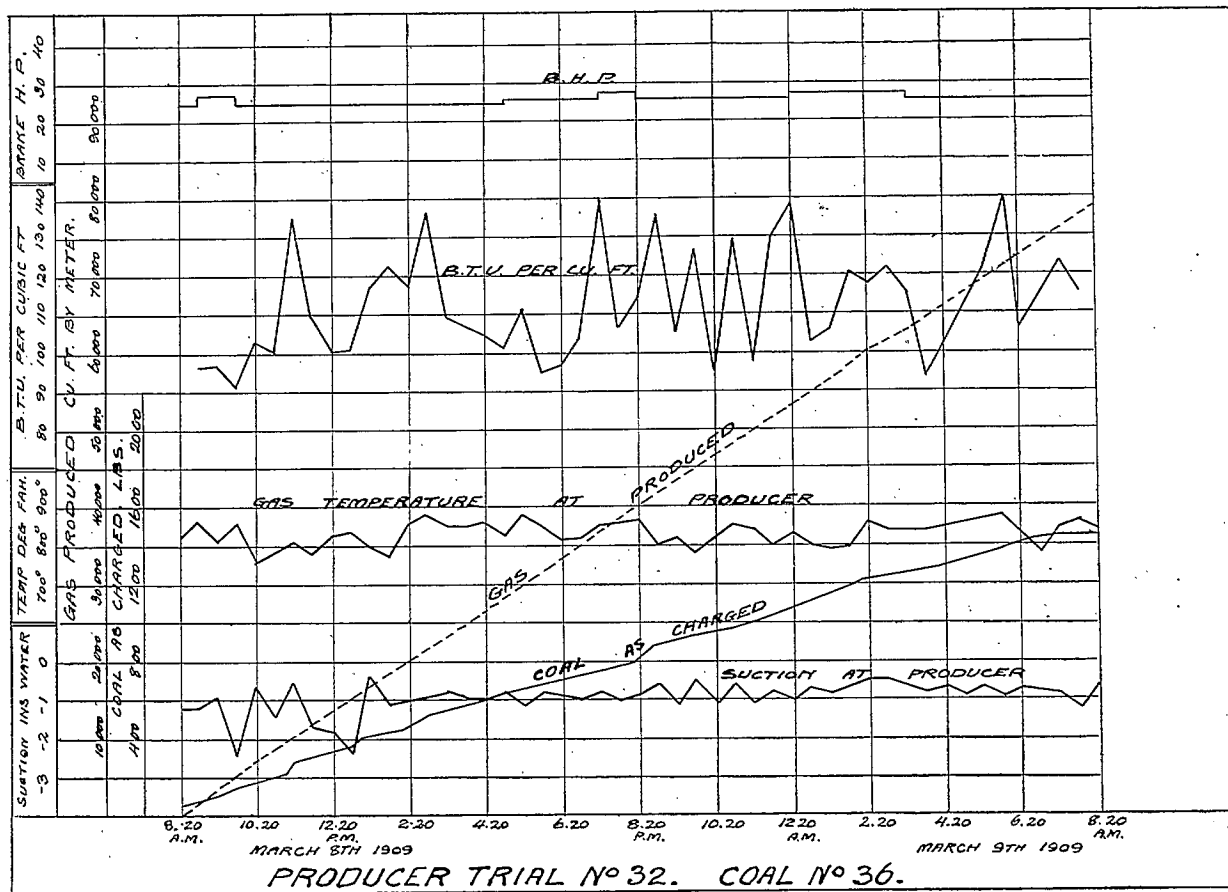

Typical Example of the 32 Sheets of Curve Diagrams of Gas Producer Tests in Appendix III, Vol. V.

Summary of Results

Total Quantities—

31.	Dry coal charged during trial	lbs. 1415
32.	Combustible charged during trial	lbs. 1343
33.	Average B.H.P. of engine during trial	H.P. 25.2
34.	Average indicated H.P. of engine during trial . .	H.P. 40.3
35.	Average H.P. taken by exhauster and gas washer	H.P. 4.0
36.	Average B.H.P. while gas consumption of engine was taken	H.P. 25.2
37.	Average B.H.P. corresponding to total gas produced	H.P. 25.2
38.	Average B.H.P. corresponding to total gas produced and available for outside use, allowing for power used.	H.P. 21.2

Hourly Quantities—

39.	Coal charged per hour	lbs. 60.4
40.	Dry coal charged per hour	lbs. 59.0
41.	Combustible charged per hour	lbs. 55.9
42.	Coal charged per sq. ft. of fuel bed per hour . . .	lbs. 15.1
43.	Dry coal charged per sq. ft. of fuel bed per hour	lbs. 14.7
44.	Combustible per sq. ft. of fuel bed per hour . . .	lbs. 14.0
45.	Coal (as charged) per hour equivalent to power used for auxiliaries.	lbs. 9.6
46.	Coal (as charged) per hour equivalent to steam used in producer.	lbs. 11.1
47.	Gas (by meter) supplied by producer per hour .	cub. ft. 3302
48.	Gas (dry at 60° and 14.7 lbs. per sq. in.) supplied by producer per hour	cub. ft. 3220
49.	Gas (by meter) supplied to engine per hour while gas consumption was taken	cub. ft. 3302
50.	Gas (dry at 60° and 14.7 lbs. per sq. in.) supplied to engine per hour while gas consumption was taken	cub. ft. 3220
51.	Calorific value of coal charged per hour	B.T.U. 817000
52.	Calorific value of gas produced per hour (lower value).	B.T.U. 342930
53.	Steam used in producer per hour.	lbs. 90.1

Economic Results—

54.	Gas (dry at 60° and 14.7 lbs. per sq. in.) produced per lb. of coal charged	cub. ft. 53.3
-----	--	---------------

55.	Gas (dry at 60° and 14.7 lbs. per sq. in.) produced per lb. of dry coal charged	cub. ft. 54.6
56.	Gas (dry at 60° and 14.7 lbs. per sq. in.) produced per lb. of combustible charged	cub. ft. 57.6
57.	Gas (dry at 60° and 14.7 lbs. per sq. in.) used per I. H.P. per hour	cub. ft. 79.9
58.	Gas (dry at 60° and 14.7 lbs. per sq. in.) used per B.H.P. per hour	cub. ft. 127.7
59.	Steam used in producer per lb. coal charged . . .	lbs. 1.49
60.	Water used in scrubber and gas washer per lb. coal charged	lbs. 24.77
61.	Water used in scrubber and gas washer per 1,000 cub. ft. gas produced	lbs. 453.5
62.	Efficiency of process of gas production and cleaning based on coal charged	0.42
63.	Efficiency of producer plant allowing for power used for auxiliaries.	0.35
64.	Efficiency of producer plant allowing for power used for auxiliaries, and for steam used in producer	0.30
65.	Thermal efficiency of engine based on B.H.P. . .	0.187
66.	Over all efficiency of producer and engine plant.	0.078
67.	Calorific value of gas supplied to engine per B.H.P. per hour	B.T.U. 13600
68.	Calorific value of coal charged into producer per B.H.P. per hour	B.T.U. 32450

		Coal as charged	Dry coal	Combustible
69	Pounds per hour charged into producer per B.H.P. developed by engine	2.40	2.34	2.22
70	Pounds per hour charged into producer per B.H.P. allowing for power used by auxiliaries.	2.85	2.78	2.64
71	Pounds per hour charged into producer per B.H.P. allowing for power and also for steam used by producer	3.37	3.29	3.12

TABLE XXIX.
Observations of Composition of Gas by Volume.

Trial of No. 4 producer with No. 36 coal.

Date, March 8 and 9, 1909. Trial number—32.

Observer: (Chemist) W. B. Campbell.

NOTES.—R.B. apparatus used. Samples taken on pressure side of exhauster.

Sample No.	Time of sampling	Amt. taken c.c.	Carbon dioxide	Oxygen	Ethylene	Carbon monoxide	Methane	Hydrogen	Nitrogen	Inflam- mable gas %
	a.m.									
1	9.05	100	8.9	0.8	0.3	8.6	4.4	11.7	65.3	25.0
2	10.00	100	9.7	0.5	0.1	14.4	3.2	10.4	61.7	28.1
3	11.00	100	9.1	0.6	0.0	13.4	2.6	7.5	66.8	23.5
4	12.00	100	10.0	0.5	0.2	8.4	4.2	9.8	66.9	22.6
	p.m.									
5	1.00	100	10.0	0.3	0.0	13.9	2.5	4.1	69.2	20.5
6	2.00	100	10.9	0.4	0.1	10.0	3.2	7.6	67.8	20.9
7	3.00	100	12.3	0.2	0.2	10.4	3.3	14.4	59.2	28.3
8	4.00	100	12.9	0.3	0.0	11.6	2.0	14.4	58.8	28.0
9	5.00	100	13.7	0.2	0.0	10.4	2.9	12.2	60.6	25.5
10	6.30	100	10.6	0.7	0.0	13.3	2.7	11.8	60.9	27.8
11	8.00	100	10.7	0.5	0.2	12.7	3.1	9.8	63.0	25.8
12	9.30	100	10.3	0.6	0.0	15.1	2.5	9.6	61.9	27.2
13	10.50	100	8.8	0.6	0.4	11.2	4.4	16.0	58.6	32.0
	a.m.									
14	12.30	100	10.3	0.5	0.0	10.7	3.6	13.2	61.7	27.5
15	1.50	100	12.0	0.8	0.0	10.1	2.8	14.4	59.9	27.3
16	3.50	100	12.4	0.5	0.0	12.8	1.9	9.7	62.7	24.4
17	4.50	100	13.4	0.7	0.0	10.1	2.4	14.4	59.0	26.9
18	5.50	100	10.8	0.7	0.3	8.7	5.6	14.3	59.6	28.9
19	6.50	100	10.1	0.6	0.1	9.9	4.2	10.9	64.2	25.1
Averages			10.9	0.5	0.1	11.4	3.2	11.4	62.5	

TABLE XXX

Observations of Gas Meter and B. H. P.

Trial of No. 4 producer with No. 36 coal.

Date, March 8 and 9, 1909. Trial number—32.

Observers: J. S. Cameron and G. Killam.

NOTES.—All gas produced was taken by engine, relief valve on gas holder remained closed throughout trial.

Time	Main gas meter reading	Cub. feet in interval	Cub. feet Total gas by meter	Loads on tight and slack side of brake		Net load on brake	Revolution counter reading (on side shaft)	Explosion counter reading
				lbs.	lbs.			
a.m.								
8.20	2430300	250	100	150	060961	064083
8.50	2432190	1890	1890	275	110	165	
9.20	2433890	1700	3590	275	110	165	
9.50	2435710	1820	5410	250	100	150	
10.20	2437355	1645	7055	250	100	150	
10.50	2439080	1725	8780	250	100	150	077700	079393
11.20	2440990	1910	10690	250	100	150	
11.50	2442130	1140	11830	250	100	150	
p.m.								
12.20	2443800	1670	13500	250	100	150	
12.50	2445500	1700	15200	250	100	150	
1.20	2447240	1740	16940	250	100	150	
1.50	2448700	1460	18400	250	100	150	
2.20	2450240	1540	19940	250	100	150	
2.50	2451985	1745	21685	250	100	150	
3.20	2453540	1555	23240	250	100	150	
3.50	2455070	1530	24770	250	100	150	
4.20	2456900	1830	26600	250	100	150	
4.50	2458685	1785	28385	250	95	155	
5.20	2460310	1625	30010	250	95	155	
5.50	2462080	1770	31780	250	95	155	
6.20	2463845	1765	33545	250	95	155	
6.50	2465460	1615	35160	250	95	155	
7.20	2467280	1820	36980	275	108	167	
7.50	2468765	1485	38465	275	108	167	
p.m.								
8.20	2470550	1785	40250	250	95	155	
8.50	2472220	1670	41920	250	95	155	
9.20	2473750	1530	43450	250	95	155	
9.50	2475355	1605	45055	250	95	155	
10.20	2477080	1725	46780	250	95	155	
10.50	2478960	1880	48660	250	95	155	
11.20	2480430	1470	50130	250	95	155	
11.50	2482160	1730	51860	250	95	155	
a.m.								
12.20	2483740	1580	53440	250	85	165	168030	161570
12.50	2485340	1600	55040	250	85	165	
1.20	2486790	1450	56490	250	85	165	
1.50	2488500	1710	58200	250	85	165	
2.20	2489950	1450	60650	250	85	165	
2.50	2491550	1600	61250	250	85	165	
3.20	2493220	1670	62920	250	95	155	187940	179360
3.50	2494980	1760	64680	250	95	155	
4.20	2496760	1780	66460	250	95	155	
4.50	250	95	155	
5.20	2499900	3140	69600	250	95	155	
5.50	2501500	1600	71200	250	95	155	
6.20	2503200	1700	72900	250	95	155	
6.50	2504660	1460	74360	250	95	155	
7.20	2506240	1580	75940	250	95	155	
7.50	2507910	1670	77610	250	95	155	
8.20	2509540	1630	79240	250	95	155	221060	209877

TABLE XXXI

Observations of Gas Calorimeter and Coal Weighed

Trial of No. 4 producer with No. 36 coal.

Date, March 8 and 9, 1909. Trial number—32.

Observers: J. S. Cameron and G. Killam.

NOTES.—Boys' calorimeter used.

Time	Gas Temp. Deg.	Cub. ft. gas	Water Deg.		C. C. of water	B.T.U. per cub. ft.	Re- marks	Time	Coal charged	Total Coal	Time of poking	Time removing refuse
			Inlet	Outlet								
Regulating Calorimeter												
a.m.								a.m.				
8.20								8.20	50	50	8.20	
8.50	59	5/12	6.00	11.58	1810	96.0	8.50	25	75	8.50	8.50
9.20	58	"	5.57	10.97	1880	96.5	9.20	25	100	9.20	
9.50	59	"	5.65	10.62	1930	91.3	9.40	25	125	9.40	
10.20	60	1/3	6.05	11.09	1710	102.4	9.55	25	150	9.55	9.55
10.50	60	"	6.09	11.09	1770	105.2	10.20	25	175	
11.20	59	1/4	6.57	11.87	1600	134.7 ¹	10.50	25	200	10.50	
11.50 p.m.	60	5/12	6.52	12.90	1790	108.7	11.05	25	225	
								11.15	50	275	11.15	
								11.35	25	300	11.55	
12.20	61	1/3	6.25	11.54	1600	100.5	12.05	25	325	12.05	
12.50	61	1/3	6.18	11.15	1710	101.0	12.45	25	350	12.45	12.45
1.20	62	"	6.52	11.60	1910	115.4	1.05	50	400	1.05	
1.50	62	1/2	6.31	15.71	1650	122.8 ¹	1.45	25	425	1.45	
2.20	63	5/12	6.55	13.29	1830	117.1	2.10	25	450	
2.50	63	"	6.70	14.82	1770	136.5					
3.20	63	"	6.96	13.60	1730	109.1					
3.50	64	"	7.45	13.62	1820	106.9	2.45	75	525	2.40	2.45
4.20	64	1/3	7.51	13.01	1600	104.5	3.50	50	575	3.50	
4.50	66	"	11.95	16.77	1770	101.2					
5.20	65	"	7.89	13.18	1770	111.1					
5.50	65	"	8.70	12.98	1870	95.2	5.05	75	650	4.50	
6.20	65	1/2	8.60	15.63	1735	96.6	6.05	50	700	5.05	5.25
6.50	65	"	8.98	16.47	1750	104.0					
7.20	65	"	8.92	19.21	1725	140.5	7.10	50	750	7.10	
7.50	64	5/12	9.35	16.40	1600	107.0	8.10	50	800	
8.20	64	"	9.37	16.11	1790	114.6	8.40	75	875	8.30	8.30
8.50	63	7/12	9.32	20.33	1830	136.8					
9.20	63	1/2	9.42	17.42	1660	105.2					
9.50	63	"	9.47	18.90	1695	127.1	9.40	50	925	
10.20	63	"	9.82	16.98	1690	95.8	10.50	50	975	10.50	
10.50	63	"	10.02	20.05	1625	129.0	11.40	50	1025	11.40	
11.20	63	"	10.23	17.39	1755	98.7					
11.50	64	"	10.00	19.22	1780	130.0 ¹					
a.m.												
12.20	64	5/12	7.59	16.70	1600	138.1	12.15	50	1075	
12.50	63	"	7.29	14.01	1610	102.9	12.55	50	1125	12.55	
								1.35	50	1175	
1.20	63	"	7.02	13.67	1660	105.0	2.10	50	1225	2.10	2.10
1.50	63	"	7.09	14.81	1650	121.0					
2.20	63	"	7.05	14.74	1620	118.4					
2.50	63	"	6.27	14.07	1640	121.5					
3.20	64	"	7.48	14.74	1670	115.3					
3.50	64	"	7.31	12.85	1800	94.5 ²	3.50	50	1275	3.50
								4.40	50	1325	4.40	
4.20	63	"	7.20	12.88	1900	102.5	5.40	50	1375	5.40	5.40
4.50	62	"	6.71	13.36	1950	123.0 ³					
5.50	63	1/3	7.15	14.56	1600	141.0 ³					
6.20	63	1/3	6.97	12.95	1640	106.5					
6.50	63	"	6.99	12.75	1690	115.7	6.25	50	1425	6.25	
7.20	63	5/12	7.00	14.06	1850	124.0	7.20	25	1450	
7.50	63	"	7.10	13.80	1840	117.0					

¹ After cooling and poking.

² Before cooling.

³ After cooling.

TABLE XXXII

Observations of Temperatures and Pressures

Trial No. 4 producer with No. 36 coal.

Date, March 8 and 9, 1909. Trial number—32.

Observers: J. S. Cameron and G. Killam.

Time	Temperatures of				Pressure, Inches of water				Suction Inches of water		Steam pressure. lbs. sq. in.	
	Pro-ducer outlet deg. F.	Gas at meter deg. F.	Room deg. F.	Engine cooling water deg. F.	Meter		Exhauster		Gas washer inlet	Pro-ducer outlet	Inlet gauge	Outlet gauge
					Outlet	Inlet	Outlet	Inlet				
a.m.												
8.20	820	64	60	103	3.7	7.2	7.4	9.2	3.4	1.2	74	70
8.50	810	65	59	143	3.6	7.0	7.2	10.5	4.7	1.2	73	69
9.20	810	65	58	141	3.4	5.7	5.9	7.6	3.4	0.9	70	66
9.50	860	65	61	140	3.7	6.6	6.8	11.0	5.3	2.5	74	70
10.20	760	66	62	138	3.4	5.3	5.5	7.0	3.2	0.7	72	68
10.50	780	66	62	136	3.5	5.8	6.0	8.8	4.1	1.4	74	70
11.20	810	66	62	140	3.0	5.7	5.9	5.8	2.7	0.5	57	53
11.50	780	66	61	137	3.1	5.7	5.9	7.8	4.0	1.7	75	72
p.m.												
12.20	820	70	64	128	3.7	6.6	6.8	10.3	4.8	1.8	72	68
12.50	840	70	64	127	3.6	6.3	6.5	10.7	5.5	2.4	70	66
1.20	800	69	65	128	3.4	5.5	5.7	7.8	3.3	0.6	70	67
1.50	770	68	62	140	3.1	4.6	4.8	7.5	3.7	1.1	70	66
2.20	850	67	63	140	3.4	6.4	6.8	9.5	4.6	1.0	74	71
2.50	880	64	65	139	3.4	6.3	6.5	9.6	4.7	0.9	74	70
3.20	850	67	65	145	3.2	5.4	5.6	8.0	3.7	0.8	73	69
3.50	850	67	67	138	3.6	6.4	6.6	10.4	4.8	1.0	73	68
4.20	860	67	66	140	3.6	6.5	6.7	11.1	4.9	1.0	71	69
4.50	830	68	70	138	3.3	5.3	5.5	7.4	4.0	0.8	65	60
5.20	880	71	67	139	3.5	6.2	6.4	9.8	5.3	1.1	68	64
5.50	850	71	67	138	3.4	6.1	6.3	8.5	4.7	0.8	69	65
6.20	820	70	66	139	3.3	5.3	5.5	8.7	4.6	0.9	70	66
6.50	820	68	65	143	3.5	6.0	6.2	8.8	5.1	1.0	54	50
7.20	850	66	64	141	3.6	6.4	6.6	9.6	4.1	0.8	42	38
7.50	860	66	64	140	3.6	6.7	6.9	9.6	5.4	1.0	78	74
8.20	810	64	63	152	3.4	5.4	5.6	9.2	5.2	0.9	56	61
8.50	800	63	63	141	3.1	5.7	5.9	7.2	3.8	0.6	54	50
9.20	820	63	63	136	3.6	6.6	6.8	9.5	5.5	1.0	55	51
9.50	780	62	63	132	3.0	5.5	5.7	8.0	4.2	0.5	50	45
10.20	820	62	64	132	3.4	6.1	6.3	9.4	5.4	1.0	52	48
10.50	850	62	65	133	3.6	6.6	6.8	8.5	5.0	0.6	52	48
11.20	840	63	65	130	3.6	6.6	6.8	9.9	5.9	1.1	50	46
11.50	800	64	65	135	3.0	5.0	5.2	7.8	4.6	0.8	61	57
a.m.												
12.20	830	64	64	132	3.2	5.3	5.5	9.5	5.4	2.0	55	52
12.50	800	65	64	132	3.3	5.3	5.5	10.0	5.9	0.7	44	40
1.20	790	65	63	133	3.1	5.1	5.3	10.2	6.0	0.8	60	57
1.50	800	65	64	132	3.1	4.8	5.0	7.8	4.7	0.6	50	47
2.20	860	66	65	129	3.3	5.3	5.5	7.8	4.7	0.5	60	56
2.50	840	66	65	130	3.2	5.7	5.9	7.0	4.6	0.5	58	55
3.20	840	66	65	132	3.3	5.4	5.6	8.7	5.2	0.7	65	62
3.50	840	67	66	131	3.4	6.0	6.1	9.4	5.8	0.8	64	61
4.20	850	67	65	130	3.4	6.0	6.1	9.4	6.0	0.7	55	52
4.50	860	66	64	128	3.5	6.1	6.3	9.7	6.0	0.9	51	48
5.20	870	66	64	132	3.2	5.8	6.0	9.5	5.9	0.7	50	47
5.50	880	66	64	130	3.3	6.0	6.2	9.4	6.0	0.7	54	50
6.20	820	66	64	132	3.4	6.4	6.8	11.0	7.0	0.9	61	58
6.50	780	66	64	135	3.2	5.5	5.7	10.0	6.0	1.0	63	60
7.20	840	66	62	134	3.3	5.5	5.7	12.5	7.0	0.9	59	55
7.50	860	66	62	131	3.2	5.4	5.5	11.6	7.1	1.2	48	45
8.20	840	66	63	133	3.4	5.6	5.8	10.9	7.1	0.7	60	57

**Calculations for Trial 32 Leading to Figures Given in Summaries of
Observations and Results, pp. 86 to 90.**

Item 3. Calorific value of coal as charged, per pound.

This is obtained from Item 4 and from the known amount of moisture in the coal as sampled during the trial and given in Item 5.

Item 4. Calorific value of dry coal per pound.

This was measured directly in each case by the chemical staff. For details of coal calorimeter methods, see Part IX.

Item 12a. Higher calorific value of gas per cubic foot by calorimeter (as observed). This was taken directly every 30 minutes during the trial, by means of a Boys' calorimeter.

The average in this case was 112.8 B.T.U. per cubic foot at 63°F. and 1" of water.

Item 12b. Higher calorific value of gas per cubic foot by calorimeter (gas dry at 60° and 14.7 lbs. per sq. inch.)

The average pressure of gas and vapour at calorimeter meter was barometric + 1" of water. One inch of water being equivalent to 0.0361 lbs. per sq. in., the total pressure of the gas and vapour at calorimeter meter was then

$$\text{Item 14} + 0.0361 = 14.65 + 0.036 = 14.686 \text{ lbs. per sq. in.}$$

From this pressure we must deduct the pressure of water vapour, in order to find the pressure of the gas itself.

From tables (Kent's Mechanical Engineers' Pocket Book, Ed. 1904, p. 484) we find that the pressure of saturated water vapour corresponding to 63° F. is 0.56 inches of mercury or 0.274 lbs. per sq. in.

Hence the gas pressure at calorimeter meter was

$$14.686 - 0.274 = 14.412 \text{ lbs. per sq. in.}$$

And one cubic foot of gas at 60° and 14.7 lbs. per sq. in. becomes

$$1 \times \frac{524}{521} \times \frac{14.70}{14.41} = 1.026 \text{ cubic feet at } 63^\circ \text{ and } 14.41 \text{ lbs. per sq. in.}$$

The higher calorific value of 1 cubic foot of gas dry at 60° and 14.7 lbs. per sq. in. is then

$$\text{Item 12b} = 112.8 \times 1.026 = 115.7 \text{ B.T.U.}$$

Item 13. Lower calorific value of gas per cubic foot (dry at 60° and 14.7 lbs. per sq. in.)

From observations it appears that in this test the heat given up by condensation of steam formed by the hydrogen in 1 cubic foot of standard gas (at 60° and 14.7 lbs. per sq. in.) was 9.2 B.T.U.

The lower calorific value is then

$$\text{Item 13} = \text{Item 12b} - \text{heat corresponding to condensation of steam} \\ 115.7 - 9.2 = 106.5 \text{ B.T.U.}$$

Item 19. Total water used in scrubber and gas washer.

From experiment 240 lbs. of water per hour were found to be used in the gas washer, hence during trial $240 \times 24 = 5760$ lbs. were used.

From observation 28880 lbs. of water were used in the wet scrubber during

23 hrs. of the trial and hence $\frac{24}{23} \times 28880 = 30150$ lbs. were used during the whole trial.

Total water used in gas scrubber and washer, therefore, is

$$\text{Item 19} = 5760 + 30150 = 35910 \text{ lbs.}$$

Item 31. Dry coal charged during trial. This is found from the total weight of coal fired, less weight of moisture, and is equal to

$$\text{Total coal fired (Item 1)} \times (1 - \text{moisture per lb. coal [from Item 2]}) \\ = 1450 (1 - 0.024) = 1415 \text{ lbs.}$$

Item 32. Combustible charged during trial.

This is found from the total weight of coal fired, and the known composition of the coal (Item 5) and is equal to

$$\text{Total coal fired} \times \frac{\% \text{fixed carbon} + \% \text{volatile matter}}{100} \\ = 1450 \times \frac{57.6 + 35.0}{100} = 1450 \times 0.926 = 1343 \text{ lbs.}$$

Item 33. Average B.H.P. of engine during trial.

This is found as follows:—

Work done on brake per minute = effective load on brake \times effective circumference of brake wheel \times revolutions per minute

$$= \text{Item 25} \times 6.28 \times \text{Item 26} \times \frac{\text{Item 23}}{\text{duration of trial}}$$

$$= 155.5 \times 6.28 \times 3.836 \times \frac{320198}{24 \times 60}$$

$$= 833500 \text{ ft. lbs.}$$

$$\text{Hence B.H.P.} = \frac{833500}{33000} = 25.2$$

Item 34. Average indicated horse-power of engine during trial.

This is found from the work done on piston per minute = area piston \times mean effective pressure on piston \times stroke \times number of explosions per minute.

$$= 113 \times \text{Item 27} \times 1.666 \times \frac{\text{Item 24}}{\text{duration of trial}}$$

$$\text{Hence I.H.P.} = \frac{132600}{33000} = 40.3$$

Item 35. Taken from ammeter and voltmeter readings on the motors driving the exhauster and gas washer respectively, and given in Items 21 and 22.

$$\text{Item 35} = \text{Item 21} + \text{Item 22} = 2.5 + 1.5 \\ = 4.0$$

Item 36. Average B.H.P. during time when gas consumption of engine was taken.

Worked out from the readings of revolution counter and load on brake taken during a period in which all gas metered was delivered to the engine, and none escaped through the relief valve on the gas holder. In this trial the relief valve remained closed during the whole 24 hours. Items 36 and 37 are, therefore, the same as Item 33.

If, however, (as in some of the trials), gas had been wasted through the relief valve, Item 37 would have been found as follows: choosing a period of at least an hour, during which the engine had taken all the gas produced, the meter readings give Item 49, gas (as metered) supplied to engine per hour; and Item 50 [gas (dry at 60° and 14.7 lbs. per sq. inch) supplied to engine per hour] can be calculated from Item 49 in the manner explained below. In a similar manner Items 47 and 48 are found. Then assuming the gas consumption per B.H.P. per hour to remain constant during the trial,

Item 37. Average B.H.P. corresponding to total gas produced.

$$= \text{Item 36} \times \frac{\text{Item 48}}{\text{Item 50}}$$

$$= \text{B.H.P. while gas consumption} \times \frac{\text{total gas furnished by producer per hour}}{\text{gas per hour supplied while consumption of engine was taken}}$$

Item 38. Average B.H.P. corresponding to total gas produced and available for outside use.

If the exhauster and gas washer had been driven directly by the engine, the plant would have been able to supply an amount of power represented by

$$\begin{aligned} \text{Item 38} &= \text{Item 37} - \text{Item 35} \\ &= 25.2 - 4.0 = 21.2 \end{aligned}$$

In this item no allowance is made for power equivalent to steam used by producer.

Item 39. Coal charged per hour.

$$\text{Item 39} = \frac{\text{Item 1}}{\text{duration of trial}} = \frac{1450}{24} = 60.4 \text{ lbs.}$$

Item 40. Dry coal charged per hour.

$$\text{Item 40} = \frac{\text{Item 31}}{\text{duration of trial}} = \frac{1415}{24} = 59.0 \text{ lbs.}$$

Item 41. Combustible charged per hour.

$$\text{Item 41} = \frac{\text{Item 32}}{\text{duration of trial}} = \frac{1343}{24} = 55.9 \text{ lbs.}$$

Item 42. Coal charged per square foot of fuel bed per hour

$$\text{Item 42} = \frac{\text{Item 39}}{\text{cross section of producer}} = \frac{60.4}{4.0} = 15.1$$

In the same way Items 43 and 44 are found from Items 40 and 41.

Item 45. Coal (as charged) per hour equivalent to power used for auxiliaries.

Item 35 gives the amount of power used for auxiliaries. If this power had been furnished by the engine, the corresponding amount of coal charged would have been

$$\begin{aligned} \text{Item 45} &= \frac{\text{Item 39}}{\text{Item 37}} \times \text{Item 35} \\ &= \frac{60.4}{25.2} \times 4.0 = 9.6 \text{ lbs.} \end{aligned}$$

Item 46. Coal as charged (per hour) equivalent to steam used.

Here it is assumed that each pound of steam supplied to the producer needs 1000 B.T.U. for its production, and that a boiler efficiency of 60 per cent is possible; hence that each pound of steam corresponds to the consumption of an amount of coal whose calorific value is $\frac{1000}{0.6}$ or 1666 B.T.U.

These assumed conditions correspond nearly to the generation of steam at atmospheric pressure from feed water at 180°F. We have then

Coal per hour equivalent to steam used

$$\begin{aligned} &= \frac{\text{lbs. steam used (Item 18)}}{\text{duration of trial}} \times \frac{1666}{\text{Cal. value of coal (Item 3)}} \\ &= \frac{2160}{24} \times \frac{1666}{13520} = 11.1 \text{ lbs.} \end{aligned}$$

Item 47. Gas (by meter) supplied by producer per hour.

$$\text{Item 47} = \frac{\text{Item 8}}{\text{duration of trial}} = \frac{79240}{24} = 3302 \text{ cub. ft.}$$

Item 48. Gas (dry at 60° and 14.7 lbs. per sq. in.) supplied by producer per hour.

The gas passing through the meter was, of course, saturated with water vapour from the scrubber and washer, and under a total pressure somewhat greater than that of the atmosphere. This pressure is Item 14 + Item 17. The temperature is given by Item 10.

Since 1" of water corresponds to a pressure of 0.0361 lbs. per sq. inch, the total pressure in the gas main at the meter was

$$\text{Item 14} + 0.0361 \times \text{Item 17} = 14.65 + 0.0361 \times 4.62 = 14.816 \text{ lbs. per sq. in.}$$

The pressure of saturated water vapour at a temperature of 66° F. (Item 10) is given by tables ¹ as 0.647 inches of mercury or 0.317 lbs. per sq. in. Hence the pressure of the dry gas is 14.816 - 0.317 = 14.499 or say 14.50 lbs. per sq. in.

The gas produced per hour, if at 66° F. and at a pressure of 14.70 lbs. per sq. in. instead of 14.50, would have a volume given by Item 47 $\times \frac{14.50}{14.70}$

Further, if the temperature had been 60° F. (521° absolute) instead of 66° (527° absolute) the volume of gas per hour would have been

$$\begin{aligned} \text{Item 48} &= \text{Item 47} \times \frac{14.50 \times 521}{14.70 \times 527} \\ &= 3302 \times \frac{14.50 \times 521}{14.70 \times 527} = 3220 \text{ cub. ft.} \end{aligned}$$

¹ Kent's Mechanical Engineers' Pocket Book, Ed. 1904, p. 484.

Item 49. Gas (by meter) supplied to engine per hour while consumption was taken.

This is evidently obtained from the meter readings taken during a period in which the whole of the gas produced went to the engine (in this case the whole trial may be taken) and in this trial is the same as Item 47.

Item 50. Is obtained from Item 49 by exactly the same method as that used in getting Item 48 from Item 47. Evidently in this case Item 50 = 3220 cub. ft.

Item 51. Calorific value of coal charged per hour.

$$\begin{aligned}\text{Item 51} &= \text{Item 39} \times \text{Item 3} \\ &= 60.4 \times 13520 = 817000 \text{ B.T.U.}\end{aligned}$$

Item 52. Calorific value of gas produced per hour.

The calorific value of gas as measured by the calorimeter (Item 12) is not quite the same as that of the gas as it passes through the main gas meter, on account of differences in pressure and temperature. Item 52 is, therefore, to be obtained from the gas produced per hour reduced to 60° and 14.7 pounds per sq. in. (Item 48) and its calorific value (Item 13).

$$\begin{aligned}\text{Item 52} &= \text{Item 48} \times \text{Item 13} \\ &= 3220 \times 106.5 \\ &= 342,930 \text{ B.T.U.}\end{aligned}$$

The lower value is used because the engine exhausts at such a high temperature that none of the heat given out in condensation can be utilized.

Item 53. Steam used in producer per hour.

$$\text{Item 53} = \frac{\text{Item 18}}{\text{duration of trial}} = \frac{2160}{24} = 90.1 \text{ lbs.}$$

Item 54. Gas (standard conditions) per pound of coal charged.

$$\text{Item 54} = \frac{\text{Item 48}}{\text{Item 39}} = \frac{3220}{60.4} = 53.3 \text{ cub. ft.}$$

Item 55.

$$\begin{aligned}\text{Item 55} &= \frac{\text{Item 48}}{\text{Item 40}} = \frac{3220}{59.0} = 54.6 \text{ cub. ft.} \\ \text{and}\end{aligned}$$

Item 56.

$$\text{Item 56} = \frac{\text{Item 48}}{\text{Item 41}} = \frac{3220}{55.9} = 57.6 \text{ cub. ft.}$$

Item 57. Gas (standard conditions) consumed per I.H.P. hour.

$$\begin{aligned}\text{Item 57} &= \frac{\text{Item 48}}{\text{average I.H.P. corresponding to total gas produced}} \\ &= \frac{\text{Item 48}}{\text{Item 37} \times \frac{\text{Item 34}}{\text{Item 33}}} \\ &= \frac{3220}{25.2 \times \frac{40.3}{25.2}} = 79.9 \text{ cub. ft.}\end{aligned}$$

Item 58. Gas (standard conditions) consumed per B.H.P. hour.

$$\text{Item 58} = \frac{\text{Item 49}}{\text{Item 36}} = \frac{3220}{25.2} = 127.7 \text{ cub. ft.}$$

Item 59. Steam used in producer per pound of coal charged.

$$\text{Item 59} = \frac{\text{Item 18}}{\text{Item 1}} = \frac{\text{Item 53}}{\text{Item 39}} = \frac{90.1}{60.4} = 1.49 \text{ lbs.}$$

Item 60. Water used in scrubbers and gas washer per pound of coal charged.

$$\text{Item 60} = \frac{\text{Item 19}}{\text{Item 1}} = \frac{35910}{1450} = 24.77 \text{ lbs.}$$

Item 61. Water used in scrubbers and gas washer per thousand cubic feet of gas produced.

$$\text{Item 61} = \frac{\text{Item 19} \times 1000}{\text{Item 8}} = \frac{35910 \times 1000}{79240} = 453.5 \text{ lbs.}$$

Item 62. Efficiency of process of production and cleaning gas, based on coal charged.

$$\text{Item 62} = \frac{\text{Item 52}}{\text{Item 51}} = \frac{342930}{817000} = 0.42$$

Item 63. Efficiency of producer plant allowing for power used for auxiliaries.

Here the B.H.P. available for outside use (Item 38) is 21.2 and the gross B.H.P. (Item 37) was 25.2. The gas expended per hour in producing the 21.2 B.H.P., therefore, had a calorific value.

$$\begin{aligned} \text{Item 52} \times \frac{\text{Item 38}}{\text{Item 37}} &= 342930 \times \frac{21.2}{25.2} \\ &= 288,400 \text{ B.T.U.} \end{aligned}$$

The efficiency required will then be

$$\begin{aligned} \text{Item 63} &= \text{Item 52} \times \frac{\text{Item 38}}{\text{Item 37}} \div \text{Item 51} \\ &= \frac{288400}{817000} = 0.35 \end{aligned}$$

Item 64. Efficiency of producer plant allowing for power used for auxiliaries and for steam used in producer.

Here the heat expended per hour is the calorific value of coal charged in producer (Item 51) + calorific value of coal equivalent to steam used (Item 46 + Item 3), and the efficiency required will be

$$\begin{aligned} \text{Item 64} &= \frac{\text{Item 52} \times \frac{\text{Item 38}}{\text{Item 37}}}{\text{Item 51} + (\text{Item 46} \times \text{Item 3})} \\ &= \frac{288400}{817000 + 150000} = \frac{288400}{967000} \\ &= 0.30 \end{aligned}$$

Item 65. Thermal efficiency of engine based on B.H.P.

This is taken as the ratio

$$\begin{aligned} & \frac{\text{Work done at the shaft of engine per hour}}{\text{Work corr. to calorific value of gas supplied per hour}} \\ &= \frac{\text{Item 37} \times 33000 \times 60}{778 \times \text{Item 52}} \\ &= \frac{25.2 \times 33000 \times 60}{778 \times 342930} = 0.187 \end{aligned}$$

Item 66. Over all efficiency of producer and engine plant.

This is the ratio

$$\begin{aligned} & \frac{\text{Heat corresponding to gross B.H.P.}}{\text{Heat expended}} \\ &= \frac{25.2 \times 33000 \times 60}{778 \times 13520 \times 60.4} = \frac{49,900}{635,000} = 0.078 \end{aligned}$$

Item 66 can evidently also be found as the product of Items 62 and 65.

$$0.42 \times 0.187 = 0.078$$

Item 67. Calorific value of gas supplied to engine per B.H.P. per hour.

$$\begin{aligned} & \text{This is evidently Item 58} \times \text{Item 13 or } \frac{\text{Item 52}}{\text{Item 33}} \\ &= 127.7 \times 106.5 \text{ or } \frac{342930}{25.2} \\ &= 13600 \text{ B.T.U.} \end{aligned}$$

Item 68. Calorific value of coal charged into producer per B.H.P. per hour.

$$\text{This is } \frac{\text{Item 51}}{\text{Item 33}} = \frac{817000}{25.2} = 32450 \text{ B.T.U.}$$

Item 69. The figures in line 69 will be respectively

$$\begin{array}{ccc} \frac{\text{Item 39}}{\text{Item 33}} & \frac{\text{Item 40}}{\text{Item 33}} & \text{and } \frac{\text{Item 41}}{\text{Item 33}} \\ \text{or } \frac{60.4}{25.2} & \frac{59.0}{25.2} & \frac{55.9}{25.2} \\ \text{or } 2.40 & 2.34 & \text{and } 2.22 \text{ lbs.} \end{array}$$

Item 70. The coal charged contained 0.976 of its weight of dry coal and 0.926 of its weight of combustible (Items 2 and 5), hence the items in line 70 will be respectively

$$\begin{array}{ccc} \frac{60.4}{21.2} & \frac{60.4 \times 0.976}{21.2} & \text{and } \frac{60.4 \times 0.926}{21.2} \\ \text{or } 2.85 & 2.78 & \text{and } 2.64 \text{ lbs.} \end{array}$$

Item 71. The coal per hour including that equivalent to steam used is 71.5 pounds, hence the Items in line 71 will be respectively

$$\begin{array}{ccc} \frac{71.5}{21.2} & \frac{71.5 \times 0.976}{21.2} & \text{and } \frac{71.5 \times 0.926}{21.2} \\ \text{or } 3.37 & 3.29 & \text{and } 3.12 \text{ lbs.} \end{array}$$

REMARKS ON GAS PRODUCER TRIALS AND THEIR RESULTS. VALUE
OF COALS FOR GAS PRODUCER WORK.

A fuel which gives satisfactory results when burnt under a steam boiler is not necessarily so suitable for gas producer purposes. The economic value of a coal when used in a power gas producer will depend on:—

(a). The heat efficiency obtainable in the producer, or, that proportion of the heat value of the coal which can be obtained in the gas produced.

(b). The uniformity in quality of gas, and the suitability of the gas for engine use, as evidenced by its freedom from dust and tar, and its calorific value.

(c). The amount of labour required to handle the coal and resulting refuse, and to work the fire in the producer.

(d). The cost of the coal delivered at the producer house.

The results of the trials here reported give information from which an opinion may be formed as to the first three of these items, but have no connexion with the fourth. Such results can, therefore, only be of use to the reader in judging of the quality of a coal for producer work when they are taken in connexion with correct data as to the price of coal and the cost of labour at the place where it is intended to use the fuel.

TREATMENT AND CONDITION OF COALS WHEN TESTED

The treatment of the various coals before delivery to the producer house is given in Column 5, Table XXXIII. In general it may be said that all coal was passed over a $\frac{1}{2}$ " screen before use in the producer, so that smalls and dust were not used. This does not apply to the anthracite (No. 23 M), which was a mixture of buckwheat and pea sizes, or to the coal used in the two long trials, Nos. 16 and 42.

No washed coal was tested in the gas producer as there is no commercial justification for such an experiment.

GENERAL RESULTS

The leading figures of the whole series of tests will be found in Table XXXIII (Summary Record of Gas Producer Tests) in which the coals are arranged in a geographical order corresponding to that used in stating the results of the boiler trials.¹ In selecting the coals to be tested in the gas producer, it was thought advisable to choose at least one representative coal from each group, and this was done so far as the size of the samples permitted. It will be noted, therefore, that not all the coals tried under the boiler were tested in the producer. Fortunately, sufficient of nearly all the lignites was available to allow of a fairly complete series of gas producer tests being made with these fuels.

The remarks in Part VII² on the general composition of the coals will also apply to the fuels used in the gas producer.

¹ See Part VII, Table IV.

² See p. 32.

1		2		3		4		5		6		7		8		9		10		11		12		13		14		15		16		17		18		19		20		21		22		23		24		25		26		27		28		29		30		31		32		33		34		35		36		37		38		39		40		41		42		43		44		45	
No. of Line	No. of Coal	No. of Trial	NAME OF COLLIERY AND COMPANY	TREATMENT AT THE MINES. ALL SAMPLES WERE ALSO SCREENED THROUGH 3 INCH AND OVER 1/2 INCH AT MCGILL UNIVERSITY	Date of Trial	Duration of Trial	Proximate Analysis of Coal as Charged				Calorific Value of Coal as Charged	Weight of Coal Charged	Weight of Dry Coal Charged	Refuse Removed During Trial		Average Depth of Fuel Bed Above Orifice	Total Gas as Metered During Trial	Average Temp. of Gas Leaving Producer	Average Higher Calorific Value of Gas (As Metered) By Calorimeter	Average Lower Calorific Value of Gas (Corrected from gas analyses)	Analysis of Gas by Volume						Average Sulfur at Producer	Average Mean Eff. Pressure Gas Engine (Indicator)	Average B.H.P. Core. for Gas Blown Off	Average B.H.P. (Net) (Col. 32 Less Power For Auxiliaries)	Coal Charged Per Hour	Coal Charged Per Hour	Coal Per B.H.P. (Gross) Per Hour	Coal Per B.H.P. (Net) Per Hour	Standard Gas (at 14.7 Lbs. Sq. In. and 60°F.) Per Lb. of Coal	Standard Gas (at 14.7 Lbs. Sq. In. and 60°F.) Per Lb. of Coal	Steam used Per Lb. of Coal	Water used Per Lb. of Coal	Efficiency of Producer based on Cal. Value of Gas and of Coal Charged	B.T.U. In Coal Charged Per B.H.P. Hour	REMARKS	No. of Late																																															
							Fixed Carbon	Volatile Matter	Ash	Moisture				Fixed Carbon	Volatile Matter						Inches	Cubic Feet	%	%	%	%																	%	%	%	%	%	%	%	%	%	%	%	%	Inches of Water	Lbs. Per Sq. In.	Lbs.	Lbs.	Lbs.	Cubic Feet	Cubic Feet	Lbs.	Lbs.	%																									
1	36	32	Dominion No. 7, Hub seam. Dominion Coal Co., Ltd., Glace Bay, N.S.	Over 2 1/2" shaking screen and picking belt.	8-9-3-09	24	57.6	35.0	5.0	2.4	13,520	1,450	1,415	38.1	4.7	43.0	79,240	783	112.8	115.7	106.5	10.9	0.5	11.4	11.4	3.2	0.1	62.5	1.0	69.6	25.2	21.2	60.4	15.1	2.40	2.85	3,220	53.3	1.5	24.8	42.0	32,450	Gas washer gave trouble; 94 pounds of tar removed; engine valves in good condition at end of trial; fuel required much attention; fire poked 24 times.	1																																													
2	35	31	Dominion No. 9, Harbour seam. Dominion Coal Co., Ltd., Glace Bay, N.S.	Over 2 1/2" bar screen and picking table.	4-3-3-09	24	52.6	35.1	10.9	1.4	13,800	1,400	1,380	64.1	4.4	40.0	77,530	785	110.3	116.4	107.3	10.0	0.4	11.8	10.5	3.7	0.2	63.4	1.6	70.1	26.3	22.3	58.3	14.6	2.21	2.61	3,058	52.5	1.5	23.7	40.8	30,500	Gas washer blown through with steam 6 times; gas delivered to atmosphere directly twice during trial to enable the pipes to be cleaned; 148 pounds tar removed; fuel required much attention; fire poked 25 times.	2																																													
3	38	34	Dominion No. 1, Phalen seam. Dominion Coal Co., Ltd., Glace Bay, N.S.	Over 1" screen and picking table.	15-16-3-09	24	58.8	32.5	6.5	2.2	13,700	1,650	1,613	67.3	7.7	42.0	81,840	716	116.3	120.0	110.0	10.1	0.8	10.7	12.5	3.3	0.2	62.4	1.8	67.1	26.2	22.2	68.75	17.2	2.63	3.10	3,303	48.1	1.3	23.7	38.5	36,030	Gas washer blown through with steam once; 137 pounds of tar removed from wet scrubber pipes and troughs; fire was poked 24 times.	3																																													
4	37	33	Dominion No. 10, Emery seam. Dominion Coal Co., Ltd., Glace Bay, N.S.	Run of mine.	11-12-3-09	24	52.6	34.2	11.1	2.1	12,840	1,450	1,420	47.6	3.6	43.0	82,330	812	105.9	108.9	100.3	10.8	0.4	11.9	11.4	2.7	0.0	62.8	1.5	61.6	25.2	22.7	60.4	15.1	2.39	2.66	3,333	55.2	1.5	19.9	43.2	30,690	Sawdust scrubber used in place of gas washer; 97 pounds of tar removed; fuel required little attention.	4																																													
5	12	30	No. 3 colliery. Nova Scotia Steel & Coal Co., Sydney Mines, N.S.	Over 1" screen and picking belt.	1-2-3-09	24	53.2	35.4	7.8	3.6	13,180	1,200	1,156	45.0	7.2	43.7	81,920	732	105.7	108.3	98.0	12.5	0.4	11.2	13.7	3.4	0.1	59.0	0.8	70.3	28.4	24.4	50.0	12.5	1.76	2.05	3,300	66.0	1.8	30.0	49.1	23,200	Gas washer blown through with steam 4 times; 83 pounds of tar removed; fire poked 14 times.	5																																													
6	15	21	Port Hood colliery. Richmond Ry. Coal Co., Port Hood, N.S.	Over 1 1/2" shaking screen and picking belt.	17-18-1-09	24	49.2	35.3	12.7	2.8	11,440	1,950	1,895	57.5	5.4	38.0	76,650	789	125.2	125.0	116.1	11.0	0.8	11.9	11.0	2.8	0.4	62.1	1.5	68.2	29.2	25.2	81.25	20.3	2.78	3.22	3,196	39.4	1.0	18.2	39.8	31,703	Gas washer found to be packed with tar at end of trial and was cleaned with steam 4 times; 70 pounds of tar was removed; engine valves in dirty condition; fire poked 9 times.	6																																													
7	2	24	Cage Pit seam. Albion colliery. Acadia Coal Co., Ltd., Stellarton, N.S.	Run of mine.	28-29-1-09	24	56.3	30.9	10.9	1.9	12,920	1,175	1,152	47.8	4.3	42.0	89,085	875	99.3	102.7	93.6	11.8	1.1	11.2	12.1	2.6	0.2	61.0	1.8	61.6	26.8	22.8	49.0	12.2	1.83	2.15	3,065	73.7	2.2	35.0	53.3	23,650	Very little trouble from tar or clinker; 7 pounds of tar removed from wet scrubber; fire poked 10 times.	7																																													
8	8	26	Main seam, Acadia. Acadia Coal Co., Ltd., Westville, N.S.	Over 1" screen and picking belt.	15-16-2-09	24	61.6	27.5	9.0	0.9	13,600	1,450	1,422	63.8	2.7	43.0	85,630	827	99.8	101.3	91.9	10.8	0.7	10.2	11.9	3.1	0.2	63.1	1.5	62.3	26.5	22.5	60.4	15.1	2.28	2.68	3,510	58.2	1.4	26.6	39.3	31,010	Gas washer cleaned with steam twice; pipes cleaned out twice; 55 pounds of tar removed; fire did not arch or clinker and was poked 17 times; engine valves in good condition at end of trial.	8																																													
9	3	23	Main seam, Drummond colliery. Intercolonial Coal Co., Westville, N.S.	Over 1 1/2" screen and picking belt.	25-26-1-09	23	62.7	24.0	12.0	1.3	12,780	1,100	1,086	53.1	4.8	40.0	86,600	824	101.5	106.0	97.7	11.4	0.5	12.2	11.6	2.2	0.2	61.9	2.2	64.5	27.1	22.1	47.8	11.9	1.76	2.16	3,605	75.5	1.9	36.5	57.8	22,493	Steam used in gas washer; no trouble from tar; 35 pounds of tar removed; engine valves were in good condition; fire poked 11 times.	9																																													
10	5	22	No. 2 colliery. Cumberland Ry. & Coal Co., Springhill, N.S.	Over 1" screen and picking belt.	21-22-1-09	24	50.4	31.4	7.3	1.9	13,120	1,375	1,348	55.8	6.0	42.0	87,535	757	100.7	104.0	93.8	11.7	1.2	10.4	12.4	3.5	0.2	60.6	0.9	63.8	27.7	23.7	57.3	14.3	2.67	2.42	3,512	61.3	1.7	29.5	43.8	27,160	Gas washer blown through with steam 5 times; 33 pounds of tar removed from wet scrubber and 1 pound from gas washer; fire poked 23 times; engine valves in good condition at end.	10																																													
11	10	27	Joggins colliery. Canada Coal & Ry. Co., Ltd., Joggins, N.S.	Over 1 1/2" screen and picking belt.	18-19-2-09	24	45.0	34.4	18.1	2.5	11,390	1,425	1,389	43.0	5.8	42.0	86,530	769	105.5	107.2	98.9	10.4	0.8	12.1	10.6	2.7	0.1	63.3	1.8	67.2	28.2	24.2	59.4	14.9	2.45	3.304	56.6	1.5	25.3	48.6	23,840	Gas washer blown through with steam 3 times; 41 pounds of tar removed; engine valves slightly tarred; fire did not arch or clinker, was poked 13 times.	11																																														
12	11	29	King's mine. S. H. King, Minto, N.B.	Over 1 1/2" screen, no picking belt.	25-26-2-09	24	53.3	32.7	12.7	1.3	12,720	1,125	1,110	49.8	5.7	43.3	89,170	773	101.5	108.2	98.3	9.2	0.6	13.7	12.1	3.4	0.2	60.8	1.0	60.8	27.7	23.7	46.8	11.7	1.69	1.98	3,225	69.0	1.9	28.1	53.1	21,497	Gas washer blown through with steam 4 times; 119 pounds of tar removed; fire poked 12 times.	12																																													
13	2010	8	Western Dominion Collieries Ltd., Tylerton, Sask.	Run of mine coal.	16-17-11-08	24	36.7	32.8	7.2	23.3	8,300	1,625	1,247	Analysis Not Taken	35.0	11.595	529	118.0	122.4	112.7	11.7	0.9	15.05	11.48	3.75	0.00	57.12	3.3	65.2	29.7	26.2	67.7	16.9	2.28	2.58	2,875	42.5	**	16.3	37.8	18,924	Very little tar formed; slight tendency of fuel to arch; fire poked 5 times.	13																																														
14	2010	17	Western Dominion Collieries Ltd., Tylerton, Sask.	Run of mine coal.	4-5-1-09	19	32.2	43.3	11.1	13.4	9,370	1,475	1,278	38.0	9.8	34.0	59,200	529	124.2	128.3	117.4	11.6	1.0	13.3	11.0	3.6	0.1	56.4	1.7	73.1	31.3	28.8	77.7	19.4	2.48	2.70	3,019	38.8	0.0	11.1	48.8	23,210	No tar removed; neither gas washer nor sawdust scrubber used, 2 hours before the end the baffle brick broke causing a high suction; fire poked 4 times.	14																																													
15	42	15	Parkdale Coal Co., Ltd., Edmonton, Alta.	Over bar screen 1 1/2" openings.	10-11-12-08	24	42.8	28.7	11.2	17.3	8,940	1,925	1,590	28.9	8.4	29.6	75,375	594	128.1	139.0	119.5	11.02	0.93	14.5	12.9	3.7	0.05	5.72	1.5	72.1	30.7	28.2	80.2	20.1	2.61	2.84	3,086	38.5	0.0	15.6	51.4	23,330	No tar removed; neither gas washer nor sawdust scrubber used; fire poked 11 times.	15																																													
16	45	10	Standard Coal Co., Edmonton	Over short bar screen 1 1/2" openings.	23-24-11-08	20	46.0	31.2	7.5	15.3	9,610	1,201	1,070	Analysis Not Taken	44.0	60,135	517	124.5	129.5	118.6	11.16	0.92	15.07	13.76	3.68	0.0	55.71	1.8	61.7	29.6	26.1	63.0	15.8	2.13	2.42	2,890	45.7	0.0	13.2	56.6	20,470	No difficulty from tar; fire showed a tendency to clinker and was poked 5 times.	16																																														
17	46	11	Strathcona Coal Co., Strathcona, Alta.	15 sacks over 2 1/2" bar screen and 10 sacks over 1 1/2" bar screen; representing screened coal over 1 1/2" screen.	26-27-11-08	17 1/2	41.4	30.9	11.9	16.1	9,010	1,132	950	27.9	6.5	40.0	59,018	581	124.3	130.2	119.0	12.0	0.4	14.08	15.0	3.3	0.02	54.6	1.0	67.0	34.8	31.3	63.7	15.9	1.83	2.04	3,175	49.8	0.8	19.6	65.7	16,490	No difficulty from tar; fire showed a tendency to arch and clinker a little; fire poked twice.	17																																													
18	43	12	Canada West Coal Co., Ltd., Taber, Alta.	53 sacks of lump and 22 sacks of nuts; representing screened coal over 1 1/2" shaking screen.	30-11-08-1-12-08	24	44.5	26.6	16.3	12.6	9,650	1,725	1,508	47.7	5.7	43.5	77,705	557	124.1	131.0	120.0	11.53	0.65	12.79	15.22	3.08	0.00	56.73	1.5	68.7	29.5	26.0	71.9	18.0	2.42	2.76	3,065	42.6	1.0	17.4	53.4	23,350	Traces of tar from wet scrubber; coal shows a tendency to form clinker; fire poked 14 times.	18																																													
19	44	13	Galt colliery. Alberta Ry. & Irrigation Co., Ltd., Lethbridge, Alta.	Over 1 1/2" screen and picking table.	3-4-12-08	24	47.6	35.2	9.4	7.8	10,800	1,550	1,430	31.5	9.1	47.8	74,663	572	128.3	134.0	122.4	10.9	0.42	13.46	14.74	3.87	0.10	56.51	1.0	70.1	30.4	26.9	64.6	16.1	2.13	2.40	2,975	46.0	1.1	15.5	52.2	23,000	No difficulty from tar; fire poked 13 times.	19																																													
20	49, 42, 43, 44, 46	16			15-17-12-08	28	40.8	31.1	6.6	18.6	8,900	2,365	1,922	40.0	35.1	46.7	86,760	524	131.3	133.8	122.2	12.14	0.36	14.38	14.98	3.61	0.1	54.6	1.1	74.7	30.3	27.8	84.5	21.1	2.79	3.04	3,050	36.0	0.0	10.3	49.5	24,830	Commercial test lasting 3 days; fire banked at night; neither gas washer nor sawdust scrubber used; fire poked 8 times while running, these figures do not include coal for banking and starting (550 lbs.).	20																																													
21	48	14	Leitch colliery. Leitch Collieries Ltd., Passburg, Alberta.	Run of mine coal.	7-8-11-08	24	51.1	29.2	18.7	1.0	12,120	1,683	1,700	50.8	3.3	40.0	81,840	743	108.0	112.2	103.9	8.9	2.0	10.3	8.0	4.1	0.1	64.6	2.0	67.0	25.8	22.3	70.8	17.7	2.74	3.17	3,280	46.3	1.2	26.0	39.7	33,210	Gas washer shut down for 3 hours for cleaning; much trouble from tar at engine; 26 pounds removed from wet scrubber; fire poked 25 times.	21																																													
22	34	36	No. 2 seam. Denison colliery. International Coal & Coke Co., Coleman, Alta.	Run of mine coal.	22-23-3-09	24	56.4	24.4	18.1	1.1	11,500	1,325	1,310	29.2	4.2	41.7	86,080	739	102.3	105.8	97.3	11.7	0.5	12.3	11.7	2.4	0.1	61.3	1.2	64.2	25.7	21.7	55.2	13.8	2.14	2.54	3,47																																																				

The rate of working of the producer, as judged by the amount of coal actually *burnt* per hour per square foot of cross-section of the producer, probably did not exceed about 16 pounds per hour per square foot in the case of any of the bituminous coals tested. Higher figures than this are given in some cases for the coal *charged* into the producer per hour, but in many of the trials it will be found that owing to difficulty in working the coal, and the consequent necessity for poking, a considerable quantity passed through the producer partially unconsumed. With the lignites, higher rates of combustion, up to 20 pounds per hour per square foot, were reached without trouble from clinker.

It was desired to generate gas from each coal at a rate sufficient to enable the engine to develop 30 B.H.P., the engine being easily capable of giving 40 B.H.P. with gas of sufficiently high calorific value. With many of the coals, however, it was either impossible to make sufficiently rich gas, or the quality varied too much to enable this average power to be developed, and it will be seen that while the average B.H.P. through the 24 hours was as high as 34.8 in one trial, in others it fell as low as 23.8. It is probable that if repeat trials could have been made with many of the samples, a greater average power could have been maintained with them, and gas of a higher and more uniform calorific power generated. In some few cases it was necessary to limit the output of the producer in order to avoid excessive trouble from clinker. The results thus indicate that with many Canadian coals, producers should receive a very conservative rating, and that about 15 pounds per square foot of fuel bed per hour is a rate of combustion which should not be exceeded in estimates of the probable continuous output for a producer of a given size.

It will be noted that the amount of steam used in most of the trials was from one to three times the weight of coal charged. Of course, only a portion of this steam was decomposed by the fuel, and the remainder, by keeping the producer temperature lower than would otherwise have been the case, contributed to the somewhat high percentage of carbon dioxide in the resulting gas, and accounted to a certain extent for the low producer efficiencies attained. The large amount of steam was, however, used purposely, because it was felt that continuous operation (only to be obtained if there is no serious trouble from clinker) was the first consideration, compared to which high calorific value of gas must be a secondary matter. There is no doubt that with more practice in handling the coals most of the samples could have been worked successfully with much less steam than was actually supplied.

PRODUCER EFFICIENCY

In attempting to examine and classify the thirty two trials whose results are given in Table XXXIII, the question at once arises as to how far differences in producer efficiency (and, therefore, in economic value), as shown by the experiments, are really due to causes inherent in the coals themselves, and to what extent they are accounted for by differences in the method of working

the producer and operating the plant during the tests. Since the trials were unavoidably too short for extremely accurate results, some discussion of this point is desirable.

It has already been shown that the rate at which fuel is charged into a producer on a short trial is not the same thing as the rate at which the fuel is consumed. The apparent efficiency of the producer (as based on coal charged and given in Column 42 of Table XXXIII) is, therefore, influenced by the following considerations:—

(a). The fuel bed at the end of the trial may be poorer in combustible, and contain more ash and refuse, than was the case at the beginning. If the fuel bed is thus burnt down too much, the apparent efficiency will be too high and the coal consumption too low, since the coal fired is credited with having generated gas which was really obtained by impoverishing the fuel bed. Or, the reverse may have happened, and the apparent efficiency may be lower than the real. Variation in apparent efficiency from this cause has evidently no connexion with the nature of the fuel used.

(b). By more or less continuous working of the grate, poking, or disturbance of the fuel bed, refuse containing an undue proportion of carbon or combustible may be passed through the producer. This refuse has, of course, given up the greater part of its volatile combustible constituents, but is replaced by the addition of fresh fuel, in such a way that the combustible charged in a given time is evidently greater than the combustible consumed and actually utilized for gas-generation during the same period.

The necessity for this disturbance of the fuel bed, and consequent waste of fuel, may arise either from the nature of the coal, whose caking and adhesive qualities when heated have caused hanging of the fuel layers, or simply from the small size or improper design of the producer. Since it is hardly ever possible to utilize the combustible value of refuse removed during the working of the producer,¹ the effect in either case is to lower the efficiency.

(c). A third source of error in the experimental results is due to the fact that the producer may have been improperly worked, since it is impossible to be certain (with one or two trials only) that the working conditions best suited to each particular coal have been actually attained. Apparent efficiencies will, therefore, in most cases be too low from this cause also.

In order to illustrate this aspect of the series of trials, Table XXXIV (Proportion of combustible in coal, in refuse, and in contents of producer at end of trial) has been prepared, and will be considered in connexion with Fig. 49 in analysing the trial results. For example, it appears from Table XXXIV that in trials 24, 13, 40, 38, and 41 the contents of the producer when drawn at the end of the trial had only from 50 per cent to 60 per cent of the proportion of combustible which was originally contained in the coal as charged, whereas an average value of this ratio for all the trials was about 72 per cent. The fuel bed, then, at the end of the tests enumerated above, was relatively

¹ Except for banking fires at night, as in the special trials 16 and 42.

TABLE XXXIV

Proportion of Combustible in Coal, in Refuse, and in Producer Contents.

Coal No.	Trial No.	Coal as charged			Fixed carbon in combustible %	Combustible in refuse %	Combustible in producer contents %	Ratio		Efficiency based on coal charged %
		Fixed carbon %	Volatile matter %	Combustible %				b/a	c/a	
				a		b	c			
36	32	57.6	35.0	92.6	62.0	42.8	79.5	0.46	0.86	42.0
35	31	52.6	35.1	87.7	60.0	68.5	73.6	0.78	0.84	40.8
38	34	58.8	32.5	91.3	64.5	75.0	72.1	0.82	0.79	38.5
37	33	52.6	34.2	86.8	61.0	51.2	59.8	0.59	0.69	43.2
12	30	53.2	35.4	88.6	60.0	52.2	70.7	0.59	0.80	49.1
15	21	49.2	35.3	84.5	58.0	62.9	63.8	0.74	0.75	39.8
2	24	56.3	30.9	87.2	65.0	42.1	53.7	0.48	0.61	53.3
8	26	61.6	27.5	89.1	69.0	66.5	71.3	0.74	0.80	39.3
3	23	62.7	24.0	86.7	72.5	57.9	67.7	0.67	0.78	57.8
5	22	59.4	31.4	90.8	65.5	61.8	65.1	0.68	0.72	43.8
10	27	45.0	34.4	79.4	57.0	48.8	64.0	0.61	0.81	43.6
11	29	53.3	32.7	86.0	62.5	55.5	61.5	0.65	0.71	53.1
2040	8	36.7	32.8	69.5	53.0	*	53.0	...	0.76	57.8
2040	17	32.2	43.3	75.5	42.5	47.8	61.0	0.63	0.80	48.8
42	15	42.8	28.7	71.5	60.0	37.3	58.0	0.52	0.81	51.4
43	12	44.5	26.6	71.1	62.5	53.4	54.2	0.75	0.76	53.4
44	13	47.6	35.2	82.8	57.0	40.6	49.1	0.49	0.59	52.2
45	10	46.0	31.2	77.2	59.5	*	56.7	...	0.73	56.6
46	11	41.1	30.9	72.0	57.0	34.4	54.2	0.48	0.75	65.7
48	14	51.1	29.2	80.3	63.5	54.1	61.9	0.67	0.77	39.7
Mixed**	16	40.8	31.1	71.9	57.0	49.0	49.1	0.68	0.68	49.5
34	36	56.4	24.4	80.8	70.0	33.4	50.5	0.41	0.62	52.9
29	35	67.8	25.1	92.9	73.0	66.1	60.4	0.71	0.65	45.7
27 and 30	42	64.6	24.8	89.4	72.0	66.0	64.8	0.74	0.72	59.9
26	40	62.7	25.6	88.3	71.0	39.5	43.9	0.45	0.50	67.6
25	37	70.5	15.6	86.1	82.0	61.8	69.6	0.72	0.81	43.4
25	38	70.3	16.7	87.0	81.0	44.7	51.3	0.51	0.59	60.0
23 M	41	77.7	11.4	89.1	87.0	50.6	51.0	0.57	0.57	59.8
22 M	18	47.8	36.2	84.0	57.0	70.4	50.9	0.84	0.61	36.6
22 M	25	46.9	36.9	83.8	56.0	51.4	57.3	0.61	0.68	58.2
18	20	44.5	40.3	84.8	52.5	63.0	72.5	0.74	0.85	51.5
17	19	41.5	39.7	81.2	51.0	71.8	60.6	0.88	0.75	39.0

* In these tests the refuse was not analysed separately.

** A mixture of coals Nos. 40, 42, 43, 44, and 46 used in this test

poor in combustible, indicating that it was partially burnt out and contained less combustible than should have been the case; the fuel consumptions (given in Columns 36 and 37, Table XXXIII) for the coals used in these trials (coals Nos. 2, 44, 26, 25, and 23 M) are, therefore, probably too low and the efficiencies too high. It is, of course, possible that this impoverishment of the fuel bed may also have occurred in some other trials and that its effect may have been masked by some other condition of the trial. Further, it seems likely that the efficiencies given for the producer for trials 32, 31, 30, 26, 27, 15, 17, 37, and 20 (coals 36, 35, 12, 8, 10, 42, 2040, 25, and 18) are somewhat too low, because in these cases the fuel bed at the end of the trial appears to have been relatively rich in combustible.

In certain other cases (for instance, trial 18, coal 22 M) a low efficiency was obtained because a large amount of refuse rich in combustible was passed through the producer. This is evident on comparing trial 18 with trial 25 (made with the same coal). These instances are all discussed in detail in the following notes:—

Since the actual composition of the fuel bed at the commencement of any particular trial is unknown, it is impossible to give the exact amount by which the coal charged (as given in Column 34, Table IV), was greater or less than the amount really consumed. It will be of interest, however, to inquire what is the probable maximum value of this difference, and an estimate of this can easily be made.

For example, taking coal No. 36 (Trial 32) for which the log and observation sheets have already been given, we find that the contents of the producer at the end of the trial contained 79.3 per cent of combustible by weight, whereas the original coal contained 92.6 per cent. This corresponds to a ratio of 0.857, whereas the average value (for all the tests) of this ratio

$$\frac{\% \text{ combustible in fuel bed at end}}{\% \text{ combustible in coal charged}}$$

was 0.72 nearly. At the end of trial 32, 665 pounds of fuel and ash were removed, corresponding, therefore, to $(0.793 \times 665) = 527$ pounds of combustible. If the fuel bed at the beginning had been of the same weight as at the end, and if we assume that it should have contained 72 per cent of the combustible value of the coal as charged, its combustible content would have been $(0.72 \times 0.926 \times 665) = 444$ pounds of combustible. The difference, $(527 - 444) = 83$ pounds of combustible, corresponds to $\frac{83}{0.926}$ or 90 pounds of coal.

In this case, on the above assumptions the coal charged would be greater than the coal actually consumed by about 90 pounds, or the coal consumed would be $(1450 - 90) = 1360$ pounds. The real efficiency, instead of being 42 per cent, would then be $0.42 \times \frac{1450}{1360} = 0.448$ nearly, an increase of about $6\frac{1}{2}$ per cent.

The above estimate having been made for one of the most noticeable cases, it seems probable that efficiencies as given in Column 42, and coal consumptions as taken from Column 34, of Table XXXIII are not likely to be in error

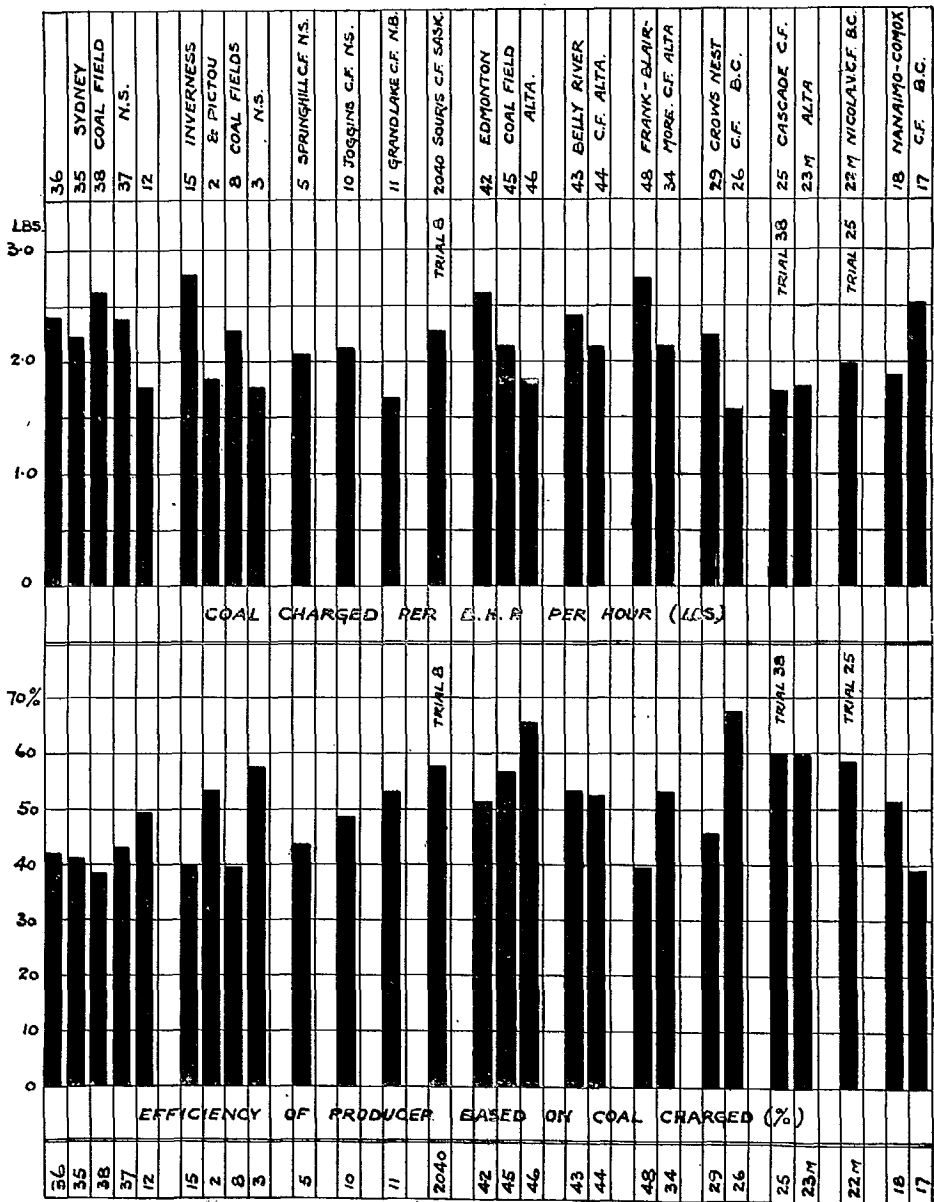

Fig. 49. Diagram showing producer efficiency and coal consumption per B. H. P. per hour.

more than 7 to 10 per cent on account of the burnt down or overcharged condition of the fuel bed at the end of the test as compared with the condition at the beginning.

The lower diagram of Fig. 49 shows in graphic form for purposes of comparison the producer efficiencies based on the coal charged and on the lower calorific value of the gas generated. The upper diagram enables a comparison to be made between the coal charged per B.H.P. per hour in the different cases. Where two tests have been made with the same coal, the better result of the two is given.

RELATIVE MERIT OF THE COALS

For various reasons it has not been thought advisable to assign any index number as a guide to the relative merit of the various coals tested in the producer, the chief difficulty in assigning such numbers arising from the uncertainty as to whether the best results were obtained in each case, and from the fact that one producer had to be used for all the bituminous coals, to some of which its design was better suited than to others. Further, there is at present no standard coal occupying the same well known position with regard to gas producer work as is held by Welsh coal, Pocahontas, or Georges Creek in connexion with boiler tests. Comparisons, where made, must, therefore, be more general in their nature than in the work of Part VII, and it must also be borne in mind that the economic results given would have been considerably higher if the work could have been done on a larger scale.

In the following notes the coals are taken by geographical groups, and it is believed that the information given is sufficient to enable the reader to form an opinion as to the difficulties of working a given coal in the producer as well as to its probable economic performance in producer work.

Fuller details as to the tests with each coal will be found in Vol. V, where the complete logs and observation sheets are reproduced for the whole series.

REMARKS ON COALS AS ARRANGED GEOGRAPHICALLY BY COAL FIELDS.

SYDNEY COAL FIELD, CAPE BRETON COUNTY, N.S.

Four gas producer trials were made on coals from the mines of the Dominion Coal Co., and one trial on a coal from one of the Nova Scotia Steel & Coal Co.'s mines.¹

These are all bituminous coals containing from 50 to 60 per cent of fixed carbon, 32 to 35 per cent of volatile matter, and varying amounts of ash. They gave gas somewhat low in calorific value, and the producer efficiency was rather low with the D. C. Co.'s samples on account of the amount of poking required, and the

¹ NOTE.—All the tests, except where otherwise specified, were made with Producer No. 4.

combustible wasted in the refuse. Coal No. 12 was the most satisfactory, and next, coal No. 37. Results from Nos. 36, 35, and 38 are probably slightly too low, as the fuel bed was found to be rich in combustible at the end of the trial in each of these cases. The coals Nos. 12 and 37 are fairly suitable for power producer work; the others involve considerable labour in a small producer, but would probably do better on a larger scale.

TABLE XXXV
Performance with Cape Breton Coals

Coal No.....	36	35	38	37	12
Description	Hub seam D. C. Co.	Harbour seam D. C. Co.	Phalen seam D. C. Co.	Emery seam D. C. Co.	No. 2 Colliery, N.S.S. & C. Co.
Volatile matter	35.0	35.1	32.5	34.2	35.4
Ash	5.0	10.9	6.5	11.1	7.8
Moisture	2.4	1.4	2.2	2.1	3.6
Cal. value of coal as charged B.T.U.	13520	13800	13700	12840	13180
Cal. value of gas (lower) per cub. ft. B.T.U.	106.5	107.3	110.0	100.3	98.0
Producer efficiency	0.420	0.408	0.335	0.432	0.491
Coal per B.H.P. per hr. lbs.	2.40	2.21	2.63	2.39	1.76
Caking of coal	tends to cake	some trouble	tends to cake	slight	no trouble
Average interval between pok- ing	1 hour	55 mins.	1 hour	2 hours	1½ hours
Clinker	no trouble	trouble from arching	small amount	no trouble	no trouble
Tar	94 lbs. rather variable	148 lbs. variable	137 lbs. rather variable	97 lbs. rather variable	83 lbs. fairly uniform
Amount of steam used	moderate	moderate	small	moderate	moderate
Combustible in refuse.	low in combus- tible	high in combus- tible	very high in combus- tible	moderate	moderate
Remarks	consider- able at- tention needed, but should have done better	great deal of atten- tion needed but should have done better	good deal of atten- tion, not very good for pro- ducer work	not much attention, fairly suit- ed for pro- ducer work	not hard to work, fair- ly well suited for producer work

INVERNESS AND PICTOU COAL FIELDS, N.S.

One trial with coal from the Port Hood colliery, Richmond Railway & Coal Co., Inverness county, two from mines of the Acadia Coal Co., and one from the Intercolonial Coal Co., Pictou county, N.S.

These are bituminous coals somewhat high in ash; the Port Hood coal is rather high in volatile matter, and appears the least suitable for power-gas

work. Coal No. 3 (Drummond colliery), in spite of its ash, gave the most satisfactory results. All four coals were easily worked in the producer. The economic results from coal No. 8 are probably slightly too low, as the fuel bed was rich in combustible at the close of the trial. A repeat of this test would have been made if sufficient material had been available. On the whole, these coals gave very good results.

TABLE XXXVI
Performance with Inverness and Pictou Coals

Coal No.	15	2	8	3
Description	Port Hood colliery, Richmond Ry. & Coal Co., Inverness co., N. S.	Cage Pit seam, Albion colliery, Acadia Coal Co. Stellarton, Pictou co., N. S.	Main seam, Acadia colliery A. C. Co., Westville, Pictou co., N. S.	Main seam, Drummond Colliery I. C. Co., Westville, Pictou co., N. S.
Volatile matter%	35.3	30.9	27.5	24.0
Ash%	12.7	10.9	9.0	12.0
Moisture%	2.8	1.9	1.9	1.3
Cal. value of coal as charged B.T.U.	11440	12920	13600	12780
Cal. value of gas (lower) per cub. ft. B.T.U.	116.1	93.6	91.9	97.7
Producer efficiency	0.398	0.533	0.393	0.578
Coal per B.H.P. per hr. lbs	2.78	1.83	2.28	1.76
Caking of coal	very little	no trouble	no trouble	no trouble
Average interval between poking	2½ hours	2½ hours	2 hours	2½ hours
Clinker	no trouble	no trouble	no trouble	no trouble
Tar	70 lbs.	7 lbs.	55 lbs.	45 lbs.
Uniformity in gas quality	fairly uniform	fairly uniform	moderate	fairly uniform
Amount of steam used . .	small	considerable	small	considerable
Combustible in refuse . .	rather high in combustible	low in combustible	high in combustible	moderate
Remarks	fairly suitable for producer work	easily worked, good for producer work	easily worked, but made poor gas, should have done better	very little attention, good for producer work

SPRINGHILL AND JOGGINS COAL FIELDS, N.S., AND GRAND LAKE COAL FIELD, N.B.

Three trials were made, one coal from each field being taken. These bituminous coals are of fair quality for producer use, although rather high in ash. Coal No. 11 gave the most satisfactory results, but yielded much tar. All three were readily worked in the producer and gave gas of low calorific value. With coal No. 10 the fuel bed was somewhat rich in combustible at the end of the trial, and the efficiency given is, therefore, slightly lower than the real value.

TABLE XXXVII

Performance with Springhill, Joggins, and Grand Lake Coals

Coal No.....	5	10	11
Description	No. 2 colliery, Cumberland Ry. & Coal Co., Springhill, N.S.	Joggins colliery, Canada Coal & Ry. Co., Joggins, N.S.	King's mine, Minto, N.B.
Volatile matter.....%	31.4	34.4	32.7
Ash.....%	7.3	18.1	12.7
Moisture.....%	1.9	2.5	1.3
Cal. value of coal as charged B.T.U.	13120	11300	12720
Cal. value of gas (lower) per cub. ft. B.T.U.....	93.8	98.9	98.3
Producer efficiency.....	0.438	0.486	0.531
Coal per B.H.P. per hour... lbs.	2.07	2.11	1.69
Caking of coal.....	no trouble	no trouble	very little trouble
Average interval between poking.	1 hour	1 hr. 50 min.	2 hours
Clinker.....	no trouble	no trouble	no trouble
Tar.....	34 lbs.	41 lbs.	119 lbs.
Uniformity in gas quality.....	rather variable	variable	fairly uniform
Amount of steam used.....	moderate	moderate	moderate
Combustible in refuse.....	moderate	moderate	moderate
Remarks.....	gave poor gas, but easily worked in producer	gave poor gas, but worked well in producer	gave poor gas and a good deal of tar, but very easy to work in producer

SOURIS COAL FIELD, SASK., EDMONTON AND BELLY RIVER COAL FIELDS,
ALTA.

Seven ordinary gas producer trials (one a repeat) and one special test were made with the lignites and lignitic coals from Saskatchewan and Alberta. The samples were mined by the Western Dominion Collieries Ltd., Taylorton, Sask.; Parkdale Coal Co., Ltd., and Standard Coal Co., Ltd., Edmonton, Alta.; Strathcona Coal Co., Ltd., Strathcona, Alta.; Canada West Coal Co., Taber, Alta.; and the Alberta Railway & Irrigation Co., Ltd., Lethbridge, Alta.

These fuels all proved excellent for use in the down-draft producer, most of them required no steam at all, and some gave so little tar that the gas washer could be dispensed with. They all have low calorific values, are moderately high in ash, and contain much intrinsic moisture. They weather rapidly and break up in the producer. Good efficiencies were obtained in each case, with gas of high calorific value and uniform in quality. Very little attention to the fire was needed, and with most of the samples the producer could have been run without the exhauster as a suction producer. The Belly River coals (Nos. 43 and 44) required slightly more attention than the others, and on the whole No. 46 (Strathcona) gave the best results.

In connexion with coal No. 2040 (Taylorton lignite) it should be noted that seven weeks (during which the fuel was kept in bags in a dry store) elapsed between trial 8 and trial 17. The change in composition of the lignite during this time is well shown, but the ageing process did not seem to make it less suitable for use in the producer.

TABLE XXXVIII
Performance with Lignites and Lignitic Coals

Coal No.	2040	2040	42	45	46	43	44
Description.	Lignite from Western Dominion Collieries Ltd., Taylorton, Sask.		Lignite from Parkdale Coal Co., Ltd., Edmonton, Alta.	Lignite from Standard Coal Co., Ltd. Edmonton, Alta.	Lignite from Strathcona Coal Co., Ltd., Strathcona, Alta.	Lignitic coal from Canada West Coal Co., Ltd., Taber, Alta.	Lignitic coal from Galt colliery, Alta. Ry. and Irrigation Co., Ltd. Lethbridge, Alta.
Vol. matter%	Trial 8 32.8	Trial 17 43.3	28.7	31.2	30.9	26.6	35.2
Ash%	7.2	11.1	11.2	7.5	11.9	16.3	9.4
Moisture%	23.3	13.4	17.3	15.3	16.1	12.6	7.8
Cal. value of coal as charged. B.T.U.	8300	9370	8940	9610	9010	9650	10800
Cal. value of gas (lower) per cub. ft. B.T.U.	112.7	117.4	119.5	118.6	119.0	120.0	122.4
Producer efficiency . . .	0.578	0.488	0.514	0.566	0.657	0.534	0.522
Coal per B.H.P. per. hr. lbs.	2.28	2.48	2.61	2.13	1.83	2.42	2.13
Caking	none	none	none	none	none	none	very slight
Average interval between poking.	5 hours	6 hours	2½ hours	5 hours	12 hours	2¼ hours	1¾ hours
Clinker	very slight	none	none	slight	slight	slight	none
Tar	none	gas washer not used, no tar	none	none	none	very little from scrubber	none
Uniformity in gas quality	very uniform	very uniform	very uniform	fairly uniform	fairly uniform	very uniform	fairly uniform
Amount of steam used	very little	none	none	none	very little	small amt.	small amt.
Combustible in refuse.	(not analysed)	moderate	moderate	(not analysed)	little combustible	rather rich in combustible	little combustible
Remarks	very suitable fuel for producer, easy to work	very suitable for producer, easy to work, no trouble	easily worked very suitable for producer	easily worked very suitable for producer	very easy to work in producer	very little trouble, easy to work	good for producer work, very little trouble

In view of the good results obtained with these fuels and the fact that a few bags of Nos. 40, 42, 43, 44, and 46 were left, it was decided to mix these and to run the plant 10 hours a day until they were used up, banking the fire at night, as would be done in a commercial installation. Trial 16 was run under these conditions and lasted three days (28 hours running time, 28½ hours with fire banked). Part of the refuse removed during the day runs was used for banking, together with 200 pounds of fresh fuel. The gas was not washed during the test, nor was the sawdust scrubber used. No steam was supplied to the fuel. No difficulty was experienced from tar or clinker, the fire required very little attention, and gas for starting was easily obtained after standing during the night.

The leading particulars of this trial are:—

Special Trial No. 16 with a mixture of lignites (Nos. 40, 42, 43, 44, and 46) (28 hours running, 28½ hours banked.)

Composition of coal:—

Fixed carbon 40.8; volatile matter 31.1; ash 9.6; moisture 18.6%.

Calorific value as charged, 8,900 B.T.U. per pound.

Gas: calorific value (lower) 122.2 B.T.U. per cub. ft. at 60° and 14.7 lbs. per sq. in.

Steam: no steam supplied.

Total coal charged during running time. 2365 lbs.

“ “ used for banking. 200 lbs.

“ “ “ “ restarting. 350 lbs.

Average B.H.P. during running time. 30.3

	Running time only	Including coal used for banking and restarting
Coal charged per B.H.P. per hr.	2.79 lbs.	3.44 lbs.
Efficiency of producer and gas cleaning apparatus	0.495	0.401

Remarks: fuel very suitable for use in a producer of the down-draft type, without the supply of any steam.

All the fuels tried in this group proved easy to work and gave good results. No. 46 showed the best efficiency. They appear much more suitable for use in a properly designed gas producer than in an ordinary steam boiler. The fuel bed analysis indicates that somewhat too much fuel was charged in the case of Nos. 42 and 2040 (trial 17), while in coal No. 44 the bed was poor in combustible; the apparent efficiency given is, therefore, probably too low for No. 42 and (trial 17) No. 2040, and slightly too high for coal No. 44.

FRANK-BLAIRMORE COAL FIELD, ALTA.

Two producer tests were made, on coals mined respectively by the Leitch Collieries Ltd., Passburg, Alta., and the International Coal & Coke Co.,

Coleman, Alta. These are bituminous coals high in ash (18 per cent); the latter seems the more suitable for gas producer work. Both yielded gas of rather low calorific value. The apparent efficiency given for No. 48 is probably slightly too low, as the fuel bed was rather rich in combustible at the end of the test. These coals do not work so easily in the producer as the coals of the last group, and No. 48 seems better as a steam coal than for producer use.

TABLE XXXIX

Performance with Frank-Blairmore Coals

Coal No.	48	34
Description	Leitch colliery, Passburg, Alta.	No. 2 seam, Denison colliery, Coleman, Alta.
Volatile matter %	29.2	24.4
Ash %	18.7	18.1
Moisture %	1.0	1.1
Calorific value of coal as charged . . . B.T.U.	12120	11590
Calorific value of gas (lower) per cub.ft. B.T.U.	103.9	97.3
Producer efficiency	0.397	0.529
Coal per B.H.P. per hr. lbs.	2.74	2.14
Caking of coal	cakes considerably	cakes slightly
Average interval between poking	55 mins.	2½ hours
Clinker.	troublesome	no trouble
Tar	26 lbs.	45 lbs.
Uniformity in gas quality	not very uniform	rather variable
Amount of steam used	moderate	moderate
Combustible in refuse	moderate	low
Remarks	Scrubbers and washers did not completely re- move tar, which was sufficient to render engine valves sticky. Coal needed much attention in producer.	No trouble from tar, fairly suitable for producer work

CROWSNEST COAL FIELD, B.C.

Two regular gas producer tests were made on representative Crowsnest coals (Nos. 29 and 26) from the Michel and Fernie mines of the Crowsnest Pass Coal Co., Ltd. In addition, a long trial (100 running hours) was made with Nos. 27 and 30. All these are coals of high quality, and worked well in the producer. No. 26 gave the best results and a very high apparent efficiency (67.6 per cent). The fuel bed analysis, however, shows that at the end of the trial the combustible content was low, and it is, therefore, likely that the real efficiency was less than 67 per cent. Probably the efficiency shown on the long trial (with very similar coal composition) is a more correct one (59.9 per cent). All the Crowsnest coals tested seem very well suited for power gas producer work.

TABLE XL

Performance with Crowsnest Coals

Coal No.....	29	26
Description	No. 8 mine, Michel colliery, Crowsnest Pass Coal Co., Ltd., Michel, B.C.	No. 5 mine, Coal Creek, Crowsnest Pass Coal Co., Ltd. Fernie, B.C.
Volatile matter	25.1	25.6
Ash	6.0	10.9
Moisture	1.1	0.8
Calorific value of coal as charged, B.T.U. ...	13330	13370
Calorific value of gas (lower) per cub. ft.	102.3	95.2
Producer efficiency	0.457	0.676
Coal per B.H.P. per hour, lbs.....	2.23	1.53
Caking of coal	Very slight	a little
Average interval between poking	2 hours	3½ hours
Clinker.....	no trouble	very slight
Tar	50 lbs.	24 lbs.
Uniformity in gas quality	fair	very uniform
Amount of steam used.....	moderate	considerable
Combustible in refuse	rather high	moderate
Remarks.....	worked well in producer	very good and easy to work

A sufficient quantity of two of the other Crowsnest coals (Nos. 27 and 30) was available for about 100 hours run, and instead of making ordinary tests with these coals, it was decided to use them for a special test under ordinary commercial conditions, running 10 hours per day and banking at night and on Sundays. This test was accordingly made from April 13 to April 24, 1909, and the results are given below. The coals used were very similar in character to Nos. 29 and 26 and to each other. The composition given in Table XXXVIII is the average of samples collected during the trial, but as the coals were not mixed, and No. 30 was used after all of No. 27 had been burnt, it may be noted that the calorific values of these two coals (as fired in the boiler trials) were respectively 13680 and 13230 B.T.U. The principal results of this test are as follows:—

Special Test No. 42 with Crowsnest Coals, Nos. 27 and 30.

(100 hours running, 162½ hours banked.)

Coal used:—

No. 27—from No. 2 mine, Coal Creek, Fernie, B.C., and

No. 30—from No. 7 mine, Michel colliery, Michel, B.C.

The first named coal was fired on April 13, 14, 15, 16, 17, 19, and 20, (70 hours running time), and coal No. 30 on the 22nd, 23rd, and 24th (30 hours running). The fire was banked at night, and all day on the 18th (Sunday) and 21st. (A defect in the exhaust piping, discovered on starting

the engine on the morning of the 21st, required so long to repair that it was impossible to get a full day's run and the fire was, therefore, banked for that day.) The two coals were so alike in quality, and received such similar treatment in the producer, that it has not been thought advisable to attempt to separate their economic results.

Composition of coal: (average of the two kinds)

Fixed carbon 64.64; volatile matter 24.82; ash 9.57; moisture 0.97%.

Calorific value as charged, 13580 B.T.U. per lb.

Gas:—Calorific value (lower), 89.9 B.T.U. per cub. ft. at 60° and 14.7 lbs. per sq. in.

Steam:—2.6 lbs. of steam per lb. of coal charged during running time.

	No. 27	No. 30	Total
Total coal charged during running time.	2875	1375	4250 lbs.
Total coal used for starting, banking, and restarting fire.	1225	275	1500
			5750
Average B.H.P. during running time			27.75
			Whole trial
Average coal per hour while running	41.1	45.8	42.5
Average coal per hour while banked	9.13	9.82	9.24
Gas per hour (60° and 14.7 lbs. per sq. in.) cub. ft.			3840
	Running time only	Whole trial including coal used for banking, and restarting fire	
Coal charged per B.H.P. per hour. . .	1.53	2.07	
Efficiency of producer and gas cleaning apparatus.	0.599	0.442	

Remarks:—So little tar that gas washer was shut down as being unnecessary after running 6 days. The gas was passed through the sawdust scrubber for the rest of the run. Some of the refuse contained enough combustible to be used for banking at night. Calorific value of gas rather low, but quality uniform. Both coals were easily worked and gave no trouble from clinker. Condition of fuel bed at end of test (as judged from analysis) was normal. Fire was poked at intervals of about 2½ hours. The engine valves were quite free at end of test.

CASCADE COAL FIELD, ALTA.

Three regular trials and one special test were made on two samples (Nos. 25 and 23 M), mined respectively by H. W. McNeil Co., Ltd., Canmore, and by the Bankhead Mines Ltd., Bankhead, Alta. These are anthracitic

coals containing 10 to 13 per cent of ash and 11 to 16 per cent of volatile matter. 23 M is a more typical anthracite than the other and can be used successfully in a regular suction producer.

Both coals worked well in Producer No. 4 and gave no trouble from tar or clinker. The first trial (No. 37) with No. 25 was somewhat unsatisfactory at first, on account of irregularity in the quality of the gas, but on using more steam a great improvement was found. The second trial (No. 38) was more satisfactory as to gas quality, but the fuel bed was rather poor in combustible at the end of the test, so that the efficiency given is probably somewhat too high. That given for trial 37 (in Table XXXIII) is probably too low.

TABLE XLI
Performance with Cascade Coals

Coal No.....	25 (Trial 38)	23 M (Trial 41)
Description	No. 1 mine, H. W. McNeil Co., Ltd., Canmore, Alta.	Mixed Pea and Buckwheat, Bankhead Mines, Ltd., Bankhead, Alta.
Volatile matter	16.7	11.4
Ash	12.3	9.9
Moisture	0.7	1.0
Calorific value of coal as charged, B.T.U. ...	13120	12950
Calorific value of gas (lower) per cub. ft. B.T.U.	87.2	102.1
Producer efficiency	0.600	0.598
Coal per B.H.P. per hr., lbs.....	1.72	1.78
Caking of coal	none	none
Average interval between times of poking	3½ hours	8 hours
Clinker	very little, gave no trouble	no trouble
Tar	20 lbs.	6 lbs. from scrubber (gas washer not used)
Uniformity in gas quality	fair	very uniform
Amount of steam used	large	large
Combustible in refuse	low	low
Remarks.....	worked well, but gave gas of very poor calorific value, no trouble, good producer coal.	fire quite free, coal worked well, no trouble.

The remainder of coal No. 23 M after trial 41 was unfortunately small in amount, but was used in a test, No. 43, with the suction producer (No. 1). The run was unavoidably too short to measure the coal consumption with any accuracy, but gas of good calorific value was obtained (considerably higher than with the larger producer No. 4), and the engine carried 35.8 B.H.P. The gas was not metered, as the producer was used on direct suction. No trouble was experienced with clinker, and this coal can be used successfully in a regular suction producer if it is not burnt at too high a rate per square foot of fuel bed. A small amount of tar began to appear at the engine towards the end of the six hours.

(8) COALS FROM THE NICOLA VALLEY AND THE NANAIMO COAL FIELDS, B.C.

Four regular tests (one a repeat) were made on coals Nos. 22 M, 18, and 17 from the mines of the Nicola Valley Coal and Coke Co., Ltd., Coutlee, B.C., and the Western Fuel Co., Ltd., Nanaimo, Vancouver island, B.C.

These are bituminous coals, high in volatile matter (35 to 40 per cent) and carrying a considerable amount of ash (12 to 16 per cent). Two appeared fairly suitable for producer work, the third (No. 17) gave some trouble.

The first trial with No. 22 M (trial 18) (see Table XXXIII) showed a low efficiency, the fire having been disturbed and worked too much and a large amount of refuse high in combustible value having been withdrawn. The repeat trial (No. 25) gave satisfactory results and the fuel bed at the close appeared normal. The refuse in trial 19 with No. 17 coal was relatively high in combustible, but heavy poking seemed unavoidable with this coal.

TABLE XLII
Performance with Nicola Valley and Nanaimo Coals

Coal No.	22 M (Trial 25)	18	17
Description	Mixture of coal from Jewelseam, No. 1 mine, and a small amount from Rat Hole seam, No. 2 mine, Middlesboro colliery, Nicola Valley Coal & Coke Co. Ltd., Coutlee, B.C.	Upper seam, No. 1 mine, Western Fuel Co., Ltd., Nanaimo, Vancouver island, B.C.	Lower seam, No. 1 mine, Western Fuel Co., Ltd., Nanaimo, Vancouver island, B.C.
Volatile matter %	36.9	40.3	39.7
Ash %	12.0	13.7	16.8
Moisture %	4.2	1.5	2.0
Calorific value of coal as charged, B.T.U.	11220	12640	12220
Calorific value of gas (lower) per cub. ft., B.T.U.	99.3	124.5	130.4
Producer efficiency	0.582	0.515	0.390
Coal per B.H.P. per hour, lbs.	1.98	1.88	2.52
Caking of coal	practically none	slight	trouble
Average interval between times of poking	4 hours	53 mins.	1½ hours
Clinker	no trouble	no difficulty	very little trouble
Tar	30 lbs.	48 lbs.	17 lbs.
Uniformity in gas quality	fair	fair	medium
Amount of steam used	moderate	moderate	moderate
Combustible in refuse	low	moderate	high
Remarks	worked easily, no trouble from tar or clinker.	needed attention, but fire was not hard to work. Trouble with tar in engine valves	required much attention. Trouble from tar, which gas washer did not remove properly.

HEAT EXPENDITURE WITH VARIOUS COALS

In Table XLIII the fuels tested have been arranged in order of the heat value of the amount of coal charged per B.H.P. per hour. This table gives the figures of Column 43, Table XXXI, but in a different order, and would give the proportional cost for fuel, assuming that all the coals were sold at the same price per thousand B.T.U. This order of arrangement is not quite fair to some coals, and gives others some slight undue advantage, but affords a general idea of the relative performance of the various groups.

TABLE XLIII

Heat Value of Coal Charged per B.H.P. per Hour

(Coals arranged in order of apparent economy.)

Coal No.	Trial No.	Description of Coal	B.H.P./hr. B.T.U.per
46	11	Lignite, Strathcona Coal Co., Edmonton, Alta.....	16490
2040	8	Lignite, Western Dominion Collieries, Ltd., Taylorton, Sask.	18924
26	40	Coal, Crowsnest Pass Coal Co., Fernie, B.C.....	20460
45	10	Lignite, Standard Coal Co., Edmonton, Alta.....	20470
27 and 30	42	Coal, Crowsnest Pass Coal Co., Fernie and Michel, B.C.....	20780
11	29	Coal, King's mine, Minto, N.B.....	21497
22 M	25	Coal, Nicola Valley Coal Co., Coutlee, B.C.....	22200
3	23	Coal, Intercolonial Coal Co., Westville, N.S.....	22493
25	38	Coal, H. W. McNeil Co., Ltd., Canmore, Alta.....	22566
23 M	41	Coal, Bankhead Mines Ltd., Bankhead, Alta.....	23000
44	13	Lignitic coal, Alberta Ry. & I. Co., Ltd., Lethbridge, Alta...	23000
12	30	Coal, Nova Scotia S. & C. Co., Sydney Mines, N.S.....	23200
42	15	Lignite, Parkdale Coal Co., Ltd., Edmonton, Alta.....	23330
43	12	Lignite, Canadian West Coal Co., Ltd., Taber, Alta.....	23350
2	24	Coal, Acadia Coal Co., Ltd., Stellarton, N.S.....	23650
18	20	Coal, Western Fuel Co., Nanaimo, B.C.....	23760
10	27	Coal, Canada Coal & Ry. Co., Ltd., Joggins, N.S.....	23840
34	36	Coal, International Coal & Coke Co., Coleman, Alta.....	24800
5	22	Coal, Cumberland Ry. & Coal Co., Springhill, N.S.....	27160
29	35	Coal, Crowsnest Pass Coal Co., Fernie, B.C.....	29730
35	31	Coal, Dominion Coal Co., Ltd., Glace Bay, N.S.....	30500
37	33	Coal, Dominion Coal Co., Ltd., Glace Bay, N.S.....	30690
17	19	Coal, Western Fuel Co., Nanaimo, B.C.....	30790
8	26	Coal, Acadia Coal Co., Ltd., Westville, N.S.....	31010
15	21	Coal, Richmond Ry. & Coal Co., Port Hood, N.S.....	31703
36	32	Coal, Dominion Coal Co., Ltd., Glace Bay, N.S.....	32450
48	14	Coal, Leitch Collieries, Ltd., Passburg, Alta.....	33210
38	34	Coal, Dominion Coal Co., Ltd., Glace Bay, N.S.....	36030

Perhaps the most striking result of the series of tests is the excellent performance of the lignites, which is well seen in this table, all the lignites taking good places. The Crowsnest coals, and Alberta anthracites are also seen to have given good results. The lower places in the table are taken (generally speaking) by coals whose caking qualities render them difficult to handle in a gas producer of small size.

THE
COALS OF CANADA:
AN ECONOMIC INVESTIGATION
VOL. II

PART IX
WORK OF THE CHEMICAL LABORATORY
BY
EDGAR STANSFIELD

PART IX

WORK OF THE CHEMICAL LABORATORY

EDGAR STANSFIELD

INTRODUCTION

The Chemical Laboratory was required to make full analyses of all coals sampled and of all products obtained in tests carried out in the different sections of the investigation. The work that had to be done was thus very considerable, especially as all methods and apparatus had to be tested and standardized, and in a number of cases new methods had to be devised and new or modified apparatus designed and built. All materials, whether raw, intermediate, or final products, had to be analysed, and although no attempt was made to keep count of the number of analyses made, a rough idea of the amount of work done can be got from the fact that a complete test of a single coal involved over four hundred separate determinations, and that over one hundred distinct consignments of coal were more or less fully tested. These facts, together with the following enumeration of the different analyses, determinations, and investigations carried out, will give some impression of the magnitude of the work involved.

Materials Analysed.—Coal samples: main, mine, weathering, boiler trial, gas producer trial, coking test, final washed coal, and separate products of washery, specific gravity tests, screen analyses, etc. Coke samples: from coking tests and special samples. Gas samples: from boiler trials, gas producer trials, and coking tests. Ash samples: from boiler trials, gas producer trials, and laboratory combustion of raw and washed coal.

Chemical Determinations Made.—Carbon, hydrogen, oxygen, sulphur, nitrogen, moisture, ash, volatile matter, fixed carbon, and combustible matter, in solids; and carbon dioxide, ethylene, oxygen, carbon monoxide, methane, hydrogen, nitrogen, sulphur dioxide, and hydrogen sulphide in gases.

Physical Determinations Made.—Fusion temperatures of ashes; specific gravity, porosity, and strength of cokes; calorific values of solid and gaseous fuels; vapour pressures; calibration of gas meters, ammeters, voltmeters, pyrometers, calorimeters, etc.

Special Investigations have been made on: the determination of sulphur in coal, determination of volatile matter in coal and also in coke, solubility of coal in water, determination of physical values of coke, weathering of coal, etc.

The analytical work was mainly carried on in the private chemical laboratory of the Professor of Mining Engineering at McGill University; this room was conveniently situated and well equipped, and proved satisfactory in most respects, but it only afforded space for two chemists at work at once without

inconvenience, and therefore, during the summer months, when the samples came in most rapidly, a second and larger room adjoining it was also used and the staff increased. A number of gas analyses and ultimate analyses were made in the special rooms set apart for these operations in the Department of Chemistry; other gas analyses were made in rooms conveniently near to the experimental boilers and gas producers; crushing tests on coke were made in the testing laboratory of the Department of Civil Engineering; fusibility tests of ashes, and some other tests, were made in the furnace room of the Department of Metallurgy; and certain physical instruments were calibrated in the laboratories of the Department of Physics. Thanks are due to the heads of the above departments of McGill University for their courtesy in allowing the use of their rooms and equipment.

The actual work of sampling, mechanical purification, and of boiler trials, was mainly done in the summer months when the several laboratores were not required for educational purposes, but the private chemical laboratory, above mentioned, was placed exclusively at the service of the coal tests staff, and in it work was carried on continuously from the spring of 1907 to the spring of 1910. During the summer months of each year, the preparation of samples, and work on certain urgently required analyses kept the staff fully occupied, and at the end of each summer there were considerable arrears of work which had to be made up later. It would have been more satisfactory to have made a complete analysis of each coal sample when received, but this would have necessitated a far larger staff and equipment than circumstances permitted.

The regular methods of analysis adopted in the routine tests are described below; the preliminary investigations carried out before deciding on these methods, together with other special investigations, will be found described in Appendix V. Vol. VI. A summary of results of analyses of all regular coal samples is given in Tables LIV to LXXI, following page 184; other analyses will be found in Parts V, and VI, Volume I, Parts VII and VIII, Volume II, and in the several appendices to the subsequent volumes.

The following trained chemists have assisted in the work: Mr. J. H. H. Nicolls, Mr. R. T. Mohan, Mr. P. H. Elliott, Mr. E. J. Conway, Mr. W. B. Campbell, Mr. W. B. Meldrum, Mr. R. S. Boehner, Mr. H. Hartley, and Mr. H. G. Morrison.

COLLECTION AND TREATMENT OF SAMPLES

COAL SAMPLES.

Regular Sample.—Each main consignment of coal was carefully sampled on arrival at the plant. In the case of the first few samples, which were dealt with in 1907, the method of coning and quartering was used, but subsequently the three shovel method was adopted and carried out as indicated in the accompanying flow sheet. The weights shown are approximate only, and are estimated for a ten ton sample.

FLOW SHEET SHOWING ORDINARY TREATMENT OF MAIN SAMPLE

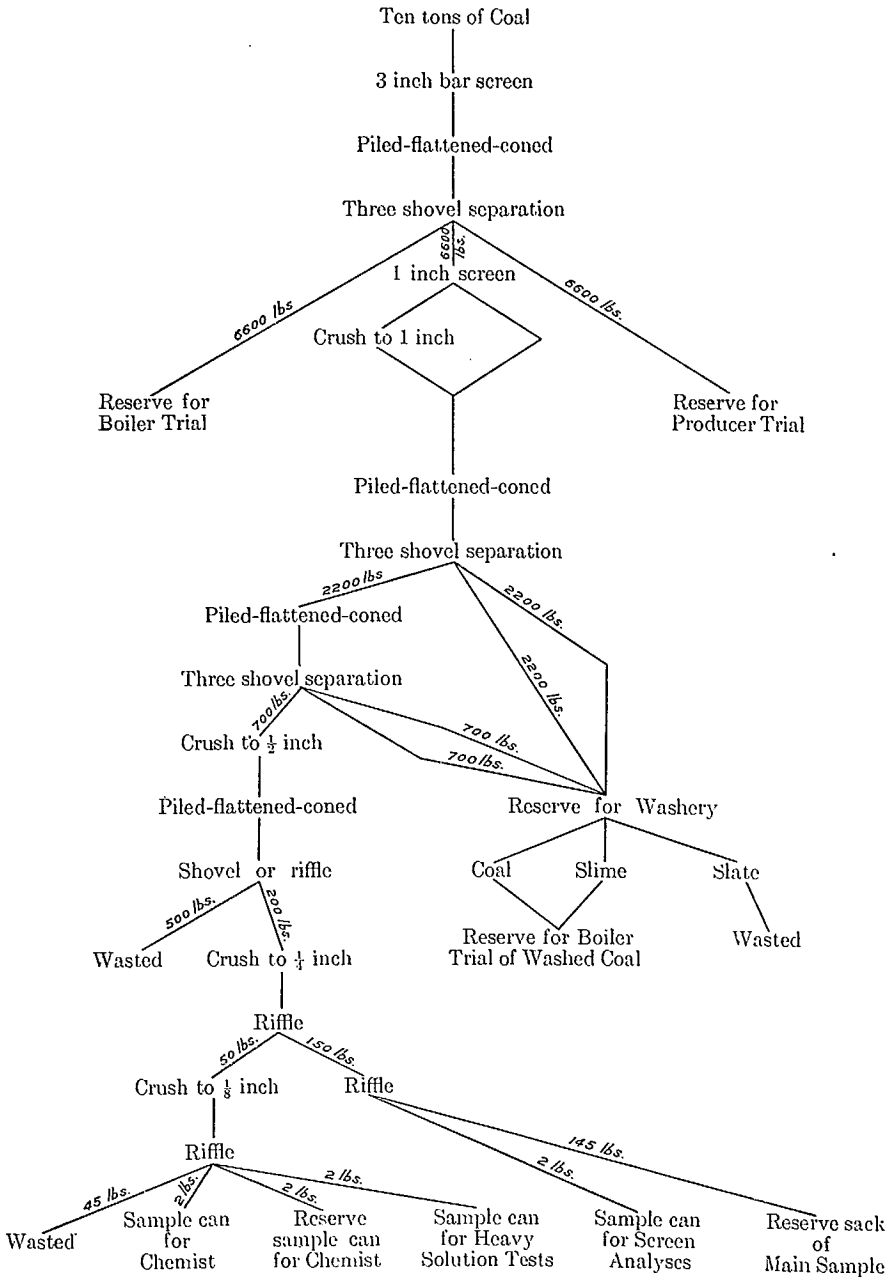

The *Regular Chemist's Sample* was placed in a sample can, carefully marked, and sent immediately to the laboratory, where the whole lot was ground for three or four hours in a small iron ball mill of 8" diameter by 5" deep, inside measurements, see Plates LII and LIII. The ordinary charge was: 4 hardened steel balls of $1\frac{3}{4}$ " diameter, 16 of $1\frac{1}{2}$ ", and 4 of 1", and 2 pounds of crushed coal; with smaller samples fewer balls were used. In all cases the mill was operated at about 100 revolutions per minute. The coal, thus ground to an almost impalpable powder, was passed through a 30 mesh sieve to ensure there being no unground nodules of pyrites; in the very few cases in which these were found they were ground up in an agate mortar and carefully remixed with the sample.

This ground sample was cut down by means of a riffle; about 200 grams were burned to furnish a sample of ash, from 50 to 100 grams were spread out on a tray 12" by 10" and dried in an oven at 105°C. for an hour, and the remainder was returned to the can and stored. The dried coal was taken out of the oven at the end of the hour, and, whilst still hot, about fourteen specimen tubes were filled with it; the coal being taken with a small spatula from several parts of the tray for each tube. The tubes were at once corked and placed in a bottle which was also corked, the tubes and bottle were carefully labelled "Dry coal No.," the label on the bottle being also dated. Two of the above specimen tubes held about two grams each, the others about one gram; the coal from one of the larger tubes was briquetted for the calorimeter, the other tubes of coal were used for the regular analyses, a fresh tube being used for each determination. Beside the above, three or four 1 gram sample tubes were filled with coal from the ball mill directly it was opened; these were stored in another bottle and labelled "Raw coal No."

The Mine Sample of coal usually arrived at the laboratory by express, in a sample can, considerably earlier than the main consignment which came by freight, in sacks; after opening the can, the coal was rapidly passed through a jaw crusher set at about $\frac{1}{4}$ ", and then spread out on a couple of trays 12" by 10", weighed, and dried in the air drying box as described later. The air dried coal was all ground in the ball mill and sample tubes were filled with air dry coal directly after opening the ball mill, and with dry coal from a tray of coal, obtained by riffing down the air dried coal from the mill, after drying in an oven for one hour at 105°C.

Samples of Coal for Weathering Tests.—The way in which these were treated will be described in Appendix V, Vol. VI.

Washed Coal Sample.—A sample can of coal was obtained from the final product of each washing either by coning and quartering or by the three shovel method, and then ground in the ball mill, etc., etc., exactly as with the main sample, except that in cases where a coal was perceptibly damp it was given a preliminary drying on a tray with gentle heat before grinding; the water driven off in this way was determined and its weight added to that found in the ground sample to give the total water in the original sample.

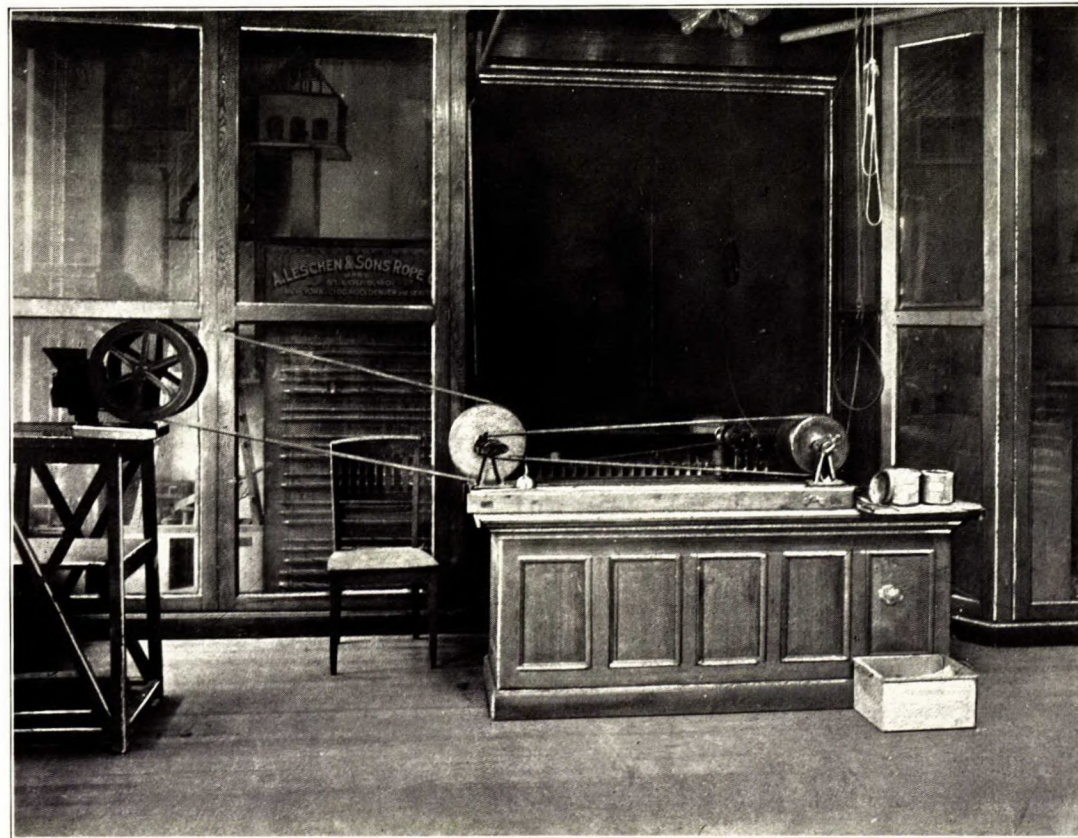

Small ball mill for grinding samples. Department of Mining and Ore Dressing, McGill University.



Small ball mill opened for cleaning. Department of Mining and Ore Dressing, McGill University.

The following example will make clear the calculation necessary:—

947 grams of coal lost 87 grams of water in the preliminary drying, that is 9.19 per cent. 0.9815 grams of the partially dried coal, after grinding, lost 0.0274 grams of water when heated for one hour at 105°C., that is 2.79 per cent.

2.79 per cent of the partially dried coal is equivalent to $2.79 \times \frac{100 - 9.19}{100}$ per cent of the original sample, that is to 2.53 per cent. Therefore, the total water in the original sample is $9.19 + 2.53 = 11.72$ per cent.

Samples of the different products of the washery, and portions obtained from heavy solution tests and screen analyses, etc., were ground on a bucking board or in an agate mortar instead of in the ball mill, and the ground samples were stored in 2 ounce bottles instead of in small specimen tubes.

Samples of Coal from Boiler and Producer Trials.—These samples were taken during the course of a trial; one shovel full of coal being taken from each lot weighed out in the case of a boiler trial, or each time of charging in the case of a producer trial, and put in a large galvanized iron receptacle with a close fitting lid. At the end of the trial the whole sample collected was sent to the sampling room where it was crushed to $\frac{3}{8}$ " and riffled down to fill a sample can; this operation could be completed within five minutes so that any moisture change would be inappreciable. This can sample was sent to the laboratory where it was ground in the ball mill, and some sample tubes filled with the fine coal direct from the mill. In some cases of boiler trials of washed coal a preliminary drying was necessary before grinding; the moisture driven off being determined and added to that subsequently found.

These boiler trial samples were "grab samples" primarily intended for determination of the moisture in the coal as fired, although ash and sometimes volatile matter and fixed carbon were also determined. The regular samples of the original and of the washed coal were so much more carefully taken and analysed that it was considered that the results obtained, corrected for the moisture found in the coal samples as taken above, would be more uniformly close to the true analysis of the coal as fired than results obtained from the product of any method of grab sampling possible during the course of a trial.

The sample cans referred to above were made of stout tinned iron and had pelly lever lids, i.e., tight fitting lids of the type commonly used for paint cans; they were 5" diameter and 5" high and held about a kilogram of crushed coal. Each can was enclosed in a slightly larger one with a slip on cover, the purpose of the outer can being to protect the inner one from physical damage. It was found that even these double cans did not entirely prevent moisture changes in the contained coal, but the loss of moisture between the mine and the laboratory could only be small. The lids of the cans containing the later mine samples, amongst which were the lignites, were sealed with paraffin wax. The can samples were marked by having their number stamped on the bottom and lid of both inside and outside cans.

All bottles and specimen tubes were closed with corks which had been impregnated with paraffin wax.

ASH SAMPLES

Regular Ash Samples were obtained by burning about 200 grams of the finely ground coal sample on roasting dishes in a muffle furnace.

Samples of Ash from Boiler and Producer Trials were obtained by taking all the ash and clinker removed during the trial and successively crushing and quartering or riffing until a small sample was obtained, which was finally ground on a bucking board to pass an 80 mesh screen, and sent to the chemist in a bottle.

COKE SAMPLES

Representative pieces of coke were chosen, as described in Part VI, Vol. I: these were crushed and riffed down to a small size and then ground on a bucking board to pass an 80 mesh screen, the product, which would weigh about 100 grams, was put in a bottle, labelled, and sent to the chemical laboratory.

It was found undesirable to grind coke in an iron ball mill as the abrasion of both the mill and the steel balls was quite noticeable.

GAS SAMPLES

Flue Gas Samples were taken from the back of the boiler in front of the opening into the flue leading to the chimney, full details being given in Part VII. For the first thirty boiler trials the flue gases were drawn off through an iron tube; this was afterwards replaced by a steel tube, enamelled both inside and out, which was used in all subsequent trials. As certain constituents of these gases react together when passed over the surface of strongly heated iron, the change to the enamelled tube was made to prevent any possibility of the gas being changed in composition when passing through the sampler tube, which is exposed to the heat of the boiler flue.

During the summer of 1907, the flue gas analyses were made in an Orsat-Muncke apparatus, and the gas was aspirated from the flue through the sampler tube and the connecting tubes and through a three-way cock in the apparatus itself. When all air had been displaced by flue gas the three-way cock was turned, thus admitting the sample directly into the measuring vessel of the apparatus. In all later boiler tests the gases were drawn through the sampler tube and through connecting tubes and a T tube to a water jet exhaust. A couple of 500 c.c. aspirator bottles, shown in Plate LVII, containing a mixture of equal parts of glycerine and water, and connected together through the side tube at the bottom of each bottle by rubber tubing, were used to collect the sample. One of the bottles was connected to the T tube mentioned above, by rubber tubing, with a spring clip on it; by raising the second bottle and opening the spring clip, the first bottle and connecting tubes were filled with

glycerine and water, up to the junction of the T tube past which the stream of flue gas was flowing. A sample of gas was then drawn into the bottle by lowering the second one, the spring clip closed, the tube disconnected from the T tube and the sample taken to the laboratory. The gas was kept under pressure, by keeping the second bottle uppermost, until it was transferred to the Randall and Barnhart apparatus for analysis, all possibility of leaks of air into the gas being thus avoided.

A mixture of glycerine and water has only slight solvent action on gases of the character tested and is probably the best substitute for mercury when collecting gas samples.

Producer Gas Samples were taken from a stop-cock tapped into the gas main on the pressure side of the blower. Aspirator sampling bottles like those described above were used, and the sample taken to the gas laboratory and transferred to the gas analysis apparatus; but at night, when it was not possible to proceed at once with the analyses, the samples were collected over water in 250 c.c. bottles, the water being driven as completely as possible out of the bottles which were then corked, labelled, and stored neck downwards in a tray of water. When the gas was required for analysis the bottles were uncorked under water and the gas withdrawn into an aspirator sampling bottle by means of a suitably bent glass leading tube.

Coke Oven Gas Samples were taken from the top of coke ovens at the Nova Scotia Steel and Coal Co., and also from the flues between the ovens and the chimney. An iron pipe of about $\frac{3}{8}$ " bore and 20 feet long was passed through the observation hole in the top of the door of an oven, in order to withdraw the gases from the top of the charge; a shorter pipe was used to take samples from the underground flues, special holes being drilled through the brickwork of the tunnel to admit the pipe. Gas was aspirated through the pipe and connecting tubes, and through a glass sample tube of about 20 c.c. capacity, by means of a rubber hand pump or by a couple of large bottles used as an aspirator, at least 5 litres of gas being drawn through. The gas sample tubes were shaped like a cylindrical pipette for liquids, but had a constriction in the tube on either side of the bulb; when they were filled with the required gas they were temporarily closed by spring clips on the connecting rubber tubes, taken to the laboratory close by and at once sealed off at the constrictions by means of a gas flame. When the samples were required for analysis the ends of the tubes were broken off under mercury in a deep trough and the gas transferred to hard glass test tubes in which it could be stored over mercury until transferred to the Bone and Wheeler gas analysis apparatus; one tube full of gas was sufficient for at least two complete analyses in this apparatus.

NUMBERING OF SAMPLES

Owing to the large number of samples, of one sort and another, which were derived from the coal taken from each particular colliery or seam sampled, it was necessary to devise a system of numbering which would at once indicate the relation of each sample to its fellow and still preserve its

individuality. The scheme adopted, which was found to work very well, can be best explained by the following illustrations:—

When a regular sample or main sample was taken at the colliery it was put into sacks marked with leather tags having a serial number—which ran from 1 up—stamped on them; this number was incorporated in the laboratory number of all samples from this mine.

An example will make this clear:—

Suppose the main sample of coal was.	33
The mine sample would be numbered.	133
The final sample of washed coal.	233
The coal sample from boiler trial of the original coal.	333
The ash sample " " " " " " " "	433
The coal sample from the boiler trial of the washed coal.	533
The ash sample " " " " " " " "	633
The coal sample from producer trial of the coal.	733
The ash sample " " " " " " " "	833
If the remainder of the original coal were resampled at a later date the resulting laboratory sample would be.	1033
A boiler trial sample after this resampling would be.	1333
A second consignment of coal from the same mine and seam would be.	2033
And a third consignment.	3033

If the original coal were, for example, 3, then the mine sample would be 103 and so on.

In some cases a sample of coal was sent from the mine in two parts, these were sampled separately then mixed and re-sampled; all three samples were analysed, but boiler trials, etc., were carried out on the mixed coal only. These two parts of the sample were originally distinguished by the labels of the one having been split with a knife. Suppose the number on the tags to be 22, then:—

Coal from the sacks with the whole tags would be.	22
" " " " " " split tags.	22 SP
And the mixed coal.	22 M
A coal sample from the boiler trial of the mixed coal.	322 M

and so on.

Samples of coal from heavy solution tests, etc., bore the number of the original coal, followed by distinctive letters and numbers.

Extra samples of coal which had not been included in the original scheme were numbered Ex. 1, Ex. 2, etc.

A sample of coke made from coal 33 if it were made in:—

An Otto-Hoffman oven at Sydney would be	C1/33
A beehive oven at Bridgeport	C2/33
A Bernard oven at Sydney Mines.	C3/33
A Bernard oven at Lille.	C4/33
A beehive oven at Coleman.	C5/33

Special samples of coke were marked C1, C2, etc.

Samples were marked dry, air dry, or raw according to the drying treatment they had, or had not received.

RECORDS AND CALCULATIONS

All records were kept, and weighings, etc., entered as made, by each chemist in his laboratory book; the calculations necessary for a determination were made from the weighings and entered in the same book. From time to time this work was transferred to the regular record books, a separate book being kept for each class of work; one, for example, was used for keeping a record of samples received, another for moisture determinations, and so on. This writing was made with a hard pencil, carbon duplicates being made which were filed away in the University vaults. Only the original, essential figures were copied from the laboratory books when transferring analyses, all subtractions and other calculations were made afresh from the original data as copied and the results were then compared with those previously obtained; this method checking both the copying of the data and the accuracy of the calculations. When the first calculations were made with four figure logarithms, a 10" slide rule was used, if possible, for checking, and vice versa; but the fourth significant figure of the result, if required, was always entered as found by the logarithms. The results obtained were also entered on record sheets, one of which was kept for each coal; it will be seen from the sample sheet appended that the results of the actual determinations are entered in the first three columns, the final analysis as reported being given in the last column. Most determinations were carried out, and calculations made, to give one more significant figure than in the result finally reported.

TABLE XLIV

Reports of Analysis of Coal—Coal Testing Laboratory.
MCGILL UNIVERSITY, DEPARTMENT OF MINING ENGINEERING.

	1	2	3	Final
1 SAMPLE 27. <i>No. 2 mine, Coal Creek colliery Crownsnest Pass Coal Co., Fernie, B.C. "Commercial screened coal." Dumped on 2" shaking screens and passed over a 70 ft. picking belt running 80 feet per minute.</i>				
2 MOISTURE--In Mine Sample—loss on air drying.....	0.90			0.9 %
—further loss at 105°C. (221°F.) (<i>ash in sample = 5.13%</i>).....	1.34			1.3 %
—total moisture.....	2.23			2.2 %
5 In Coal as charged into Boilers—Boiler Test No. <i>G. C. T. 37</i> (<i>ash in sample = 9.41%</i>).....	0.97			1.0 %
6 In Coal as charged into Producers—Pro- ducer Test No.				%
PROXIMATE ANALYSIS OF DRY COAL				
7 Fixed carbon (by difference).....				64.7 %

method of air drying, one which would be independent of variations in the atmospheric conditions. The method decided upon was that of exposing the crushed coal to air moistened by means of calcium chloride solution of specific gravity 1.30, until it ceased to lose weight, and the convention is adopted that air dried coal is coal that has been treated in this manner.

Calcium chloride solution of the above strength has a vapour pressure which is approximately 0.58 times that of water, so that air standing in contact with the solution has a humidity of 58 per cent, this not being affected by small changes of temperature. Fifty-eight per cent humidity was chosen as being an average atmospheric condition.

This process of air drying was only carried out on the mine samples sent direct in the double sample cans as described above. The cans were opened and the coal rapidly crushed to $\frac{1}{4}$ " size in a jaw crusher, spread out on two 12" \times 10" trays and weighed, the trays were then placed in a special box made reasonably air-tight, in which small laths took the place of shelves to allow free air circulation, and in which were also placed a number of trays containing lumps of pumice stone standing in the calcium chloride solution (1.30 specific gravity determined at 15°C.) See Plate LIV. The trays of coal were weighed from time to time: it was generally found that they lost in weight for about a week or ten days and then began to gain slightly, this gain was probably due to oxidation; the maximum loss was taken as the water lost on air drying. The air dried coal was ground in the ball mill and the moisture left in the ground sample determined as usual. Some lignites were found not to give a minimum weight as above even after six weeks, so the air drying was stopped when the rate of loss became very slow; but results obtained on high moisture coals are not likely to be very consistent.

The coal as charged into the boilers or producers (excluding washed coals and lignites) would ordinarily be described as dry coal. An examination of 35 coals showed the average water in the coal as charged into the boiler to be 2.14 per cent and in the corresponding mine samples air dried, to be 1.95 per cent; twenty of these coals had an average of 1.72 per cent water as charged into the producers and 1.60 per cent in the corresponding air dried mine samples. The agreement is only fairly close, but at the same time the figures given show that the water left in coal air dried as above, is approximately the same as that found in what may be described as commercial dry coal. The average moisture in the above 35 mine samples as received, and before air drying, was 2.94 per cent, the average loss in air drying was, therefore, 1.0 per cent.

ANALYTICAL METHODS AND DERIVED RESULTS

GENERAL REMARKS

The equipment of the laboratory included the following apparatus not elsewhere described in this report: a Sartorius balance and weights; a power driven agate mortar grinder; a specially designed hot air oven; a Mason hygrometer; a gas heated hot plate; an electrically

heated plate; and the usual apparatus and fittings of a chemical laboratory. None of these requires description except the oven which was about 24" × 12" × 12" inside dimensions with six shelves, heated by gas from the sides, and arranged so that it was impossible for the burnt gases to enter the oven, and so that the air which entered at the bottom passed over each shelf in order before it escaped through vent holes in the roof. The temperature of the oven was regulated by means of a gas pressure regulator "Model A," see Fig. 50 (described in paper by E. Stansfield read before the Faraday Society, May 2, 1911).

It was found to be quite impossible to be consistent in the use of units; some chemical apparatus is graded and catalogued in metric units by the dealers, and other in British units. It was not thought necessary to give the equivalents in each case, as the units given in this report are those in most common use for that particular case, e.g., an 18 mm. bore combustion tube is referred to, and so is a 6" U tube. Chemists use metric weights and measures almost exclusively; but results which are to be employed by engineers are ordinarily reported in British units.

When portions of coal samples required for any determination are weighed from a bottle into a counterpoised scoop, a pre-determined weight (e.g. 1 gram) can be taken; but there is a liability to moisture change in the sample during weighing, and, especially with coals high in sulphur and ash, there is danger of the heavier material accumulating towards the bottom of the sample bottle so that a representative portion is not obtained. If the sample is mixed on a sheet of paper before removing a portion for an analysis the latter danger is obviated, but the liability to moisture change is greater; and as the whole sample is thus exposed to the air each time a portion is removed for analysis, the difference between the moisture content of the first and last portions taken may be considerable. It was in order to overcome the above difficulties that the method of filling a large number of specimen tubes with the sample was adopted. The sample was well mixed, as already described, and each tube was filled with a thoroughly representative portion; a fresh tube was used for each determination, and its contents were weighed out without appreciable exposure to the atmosphere. When a portion of a coal sample was required for an analysis, a suitably sized sample tube of it was taken, wiped with a duster, weighed, the coal emptied into the crucible or vessel in which it was wanted, and the tube at once re-corked and re-weighed, the difference in weight giving the exact weight of coal taken; it was, of course, impossible to take a predetermined weight of the sample. The above method was used for all regular coal samples; but for coke and ash samples, and for the less important coal samples, the usual method of weighing from a bottle into a counterpoised scoop was employed. To avoid the repetition of explanations, the phrase "one gram of the sample was taken" has been used in this report to cover both the weighing of exactly one gram in a scoop, and the use of the contents of an approximately one-gram sample tube; the exact weight of the latter was, of course, employed in making the necessary calculations for the determination in question.



Drying apparatus, chemical laboratory. Department of Mining and Ore Dressing
McGill University.

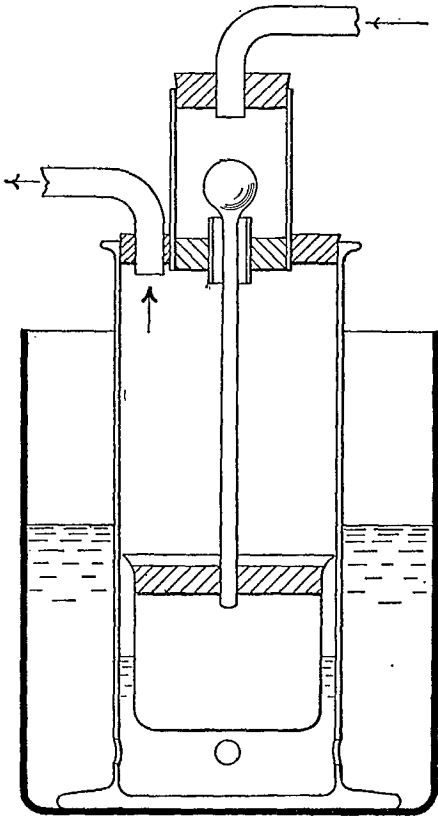

MODEL A.

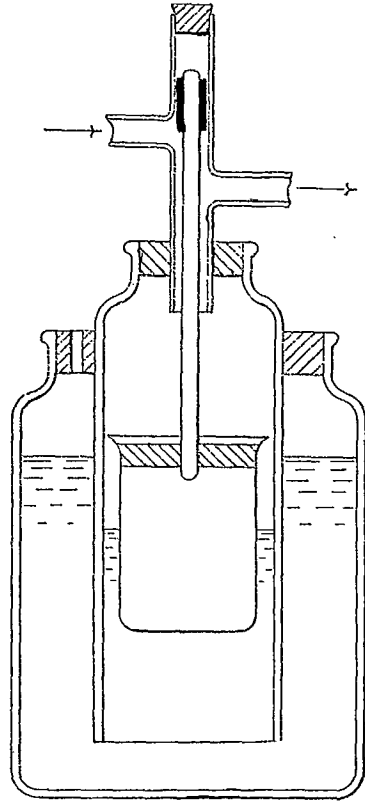

MODEL B.

Fig. 50. Stansfield pressure regulators.

When a fuel is burned in an ordinary calorimeter the products of combustion are cooled down to ordinary temperatures, and thus give up all their readily available heat. In a steam boiler or gas engine the products of combustion always escape at a temperature above that of boiling water; there is thus wasted not only the sensible heat of the gases but also the latent heat of vaporization of any steam present. The sensible heat wasted will vary with the conditions, but, as the latent heat of the steam produced is a definite and quite considerable amount and is almost inevitably wasted, it is often subtracted from the calorific value of the fuel, the result being called the net or lower to distinguish it from the determined calorific value which is called the gross or higher. The gross calorific value of a fuel can be defined as the heat evolved by the complete combustion of unit weight (or volume), when the products of combustion are cooled to water, etc., at ordinary temperatures; the net calorific value is the heat evolved by the complete combustion of unit weight (or volume), when the products of combustion are cooled to water vapour, etc., at ordinary temperatures. Throughout this report the gross values only are given, except in the case of calorific values of gases calculated from analysis where both values are given. If the latent heat of steam at ordinary temperatures is taken as 596 calories per gram (or 1073 B.T.U. per pound), then 6 calories per gram (or 11 B.T.U. per pound) have to be subtracted from the gross calorific value of a coal for each per cent of water it contains when burned, and 53 calories per gram (or 96 B.T.U. per pound) for each per cent of hydrogen it contains (other than hydrogen in the water) in order to obtain the net calorific value.

An example will show the method of calculation, and the magnitude of the correction which may be expected.

Coal No. 14, when dry, contains 4.8 per cent hydrogen and has a gross calorific value of 6750 calories per gram. As fired into the boiler it contained 7.3 per cent of water; its hydrogen content was, therefore, $4.8 \times \frac{100-7.3}{100}$ that is 4.5 per cent (not counting the hydrogen in the water), and its gross calorific value $6750 \times \frac{100-7.3}{100}$ that is 6258 calories.

Correction for water in coal is $7.3 \times 6 = 44$ calories.
 " " hydrogen in coal is $4.5 \times 53 = 239$ "

Total correction. 283 calories
 $6258 - 283 = 5975$

The gross calorific value of the coal as fired into the boiler is, therefore, 6260 calories, and the net value 5980 calories per gram, or $4\frac{1}{2}$ per cent less.

For solid fuels, calorific values are given both in calories per gram and also in British Thermal Units per pound; for gaseous fuels, they are given in British Thermal Units per cubic foot of the gas measured moist at 60°F., and under a pressure of 30" of mercury.

The current International Atomic Weights have been used throughout the work (oxygen = 16.00.)

MOISTURE.

A porcelain crucible or capsule was ignited, cooled, and weighed, one gram of the sample was taken and placed in the crucible, which

was then heated in a hot air oven to 105°C. (221°F.) for one hour. At the end of the hour the crucible was transferred to a desiccator, where it was allowed to cool over strong sulphuric acid; when cold it was again weighed, being covered during weighing by a counterpoised watch glass. The difference between the final weight and the sum of the original weights of the crucible and the coal or coke, is the loss in weight due to the water having been driven off, and from this the percentage of moisture in the sample can be calculated.

FIXED CARBON AND VOLATILE MATTER.

The volatile matter in coal was determined by heating one gram of the sample in a 20 c.c. platinum crucible having a well fitting lid, for seven minutes over the full flame of a Chaddock porcelain burner; the loss in weight gave the volatile matter. The crucible was supported by a platinum triangle resting on the top of a fireclay chimney, the triangle being about 9 cm. above the orifice of the burner; the crucible was surrounded by an iron chimney, lined with asbestos, 3.4 cm. high and 7 cm. diameter. The free flame of the burner was about 20 cm. high, the air supply being so adjusted that the inner cone of the flame just did not touch the crucible; the outside of the lid always burnt clean, but the inside was left covered with carbon.

Fixed carbon was calculated by subtracting from one hundred the sum of the percentages of volatile matter and ash.

The above method is practically that recommended by the American Chemical Society, except that dry coal is here used instead of undried coal; it was not until 1909, two years after the above method was adopted, that the method of the American Chemical Society was given international recognition. The latter method is described as follows: "Volatile Combustible Matter—Place one gram of fresh, undried, powdered coal in a platinum crucible, weighing 20 or 30 grams and having a tightly fitting cover. Heat over the full flame of a Bunsen burner for 7 minutes. The crucible should be supported on a platinum triangle with the bottom 6 to 8 cm. above the top of the burner. The flame should be fully 20 cm. high when burning free, and the determination should be made in a place free from draughts. The upper surface of the cover should burn clear but the under surface should remain covered with carbon. To find the 'Volatile Combustible Matter' subtract the percentage of moisture from the loss found here."¹

The above methods are not suitable for samples high in volatile matter such as lignites or peat, as the rapid escape of gases causes solid matter to be thrown out of the crucible. Lignites were given seven minutes heating, exactly like coal samples, except that the heating was very gentle at first until most of the volatile matter had been driven off. A few coals exploded when heated by the regular method and so had to be treated like lignites.

¹ Jour. Am. Chem. Soc., Vol. XXI (1899), p. 1122.

The above methods are also unsuited for coke, which does not generate sufficient gases to exclude the air from the crucible during the heating process; there is, in consequence, an inevitable loss of coke by oxidation, which loss must not be credited to volatile matter. A number of methods, old and new, were tested. The results of these tests are given in Appendix V, Vol. VI, the one finally adopted is as follows:—

A porcelain boat was ignited, cooled, and weighed, and filled with coke ground to pass an 80 mesh screen; it was then dried in an oven for an hour at a temperature between 105° and 115°C., cooled, and re-weighed; the increase in weight being the weight of dry coke taken. The boat was then ignited for 15 minutes, at a temperature of approximately 900°C. in an atmosphere of nitrogen in a platinum combustion tube. When cold, the boat was re-weighed, and the loss in weight taken as volatile matter.

The platinum tube was about 12" long and $\frac{1}{2}$ " diameter, it had long platinum caps at each end to which rubber tubing could be attached. A twenty-burner combustion furnace was used for heating, only those burners which were under the tube were lit and the taps for these burners, having been once adjusted to give a suitable flame, were never altered; the gas pressure at the furnace was kept at 1.6" by means of a Stansfield pressure regulator, Model B, See Fig. 50. The temperature to which the tube was heated under these conditions was determined by means of a Morse optical pyrometer to be approximately 900°C.: 1" gas pressure gave a temperature of 810°C. and 2" gave 922°C. The ends of the tube were protected from the flames by passing through pieces of asbestos, and the caps were kept cool by a strip of cloth wrapped round them down which water was slowly siphoning from a small bottle. The porcelain boats were 4" long and $\frac{1}{4}$ " wide and held about 0.6 gram of coke; larger boats would have been better, but these were the largest procurable that would go into the platinum tube. The nitrogen was generated by heating a solution of equal weights of sodium nitrite and ammonium chloride, and was stored in a large copper gas holder weighted to give about 5" of water pressure. The nitrogen was purified by passing over yellow phosphorus and through strong sulphuric acid; any oxides of nitrogen present were removed by a spiral of reduced copper placed in a porcelain boat at the front end of the platinum tube. In each experiment two boats containing dry coke and a smaller boat containing the reduced copper were placed in the tube; a moderate current of nitrogen was passed in for two minutes, the gas escaped at the back end through a glass tube which dipped under the surface of strong sulphuric acid. The nitrogen current was then reduced to a very slow stream and the furnace lit; at the end of fifteen minutes the heat was cut off and the tiles of the furnace opened to allow the tube to cool; ten minutes later the nitrogen was stopped altogether and five or ten minutes after this the porcelain boats were cold enough to take out and weigh. The copper spiral was as a rule partially oxidized, so it was reduced afresh between the experiments by being heated to redness and dropped into a test-tube containing a few drops of alcohol.

One gram of the sample was taken and put into a previously weighed crucible, which was placed in a gas-fired muffle furnace and heated, gently at first and then more strongly, until it became a fairly bright red. One hour's heating was usually sufficient to burn the coal; but to ensure complete combustion two to three hours heating was generally allowed. The muffle had a hole at the back and the door was left slightly open during the process. The crucible was then transferred to a desiccator, cooled and weighed; the weight of ash left was thus determined.

In the case of samples of refuse (ash and clinker) from boiler or producer trials; the same procedure was followed; but in this case the percentage loss, due to the ignition of the sample in the muffle, was reported as combustible matter in refuse.

The amount of ash was sometimes also determined by burning the coal in a crucible over a Bunsen burner; the muffle method, however, was preferred as the results seemed more reliable, twelve crucibles could be heated at once, and the initial heating was more easily regulated, so that there was less risk of coal being blown out of the crucible by too sudden combustion.

CARBON AND HYDROGEN

The usual method was adopted for the determination of carbon and hydrogen in coal. A weighed quantity of coal is burnt in a current of oxygen in a hard glass tube heated in a combustion furnace, the products of combustion are then passed over strongly heated copper oxide to complete their oxidation and over gently heated lead chromate which retains the sulphur. The water and the carbon dioxide thus produced are collected in suitable absorbents and weighed. The weight of the hydrogen in the coal is calculated as 0.1119 ($\log. = \bar{1}.0487$) times that of the water produced, and the carbon as 0.2727 ($\log. = \bar{1}.4357$) times the carbon dioxide.

Two important modifications of the general method were employed; the first of these modifications was practically that adopted by Prof. N. W. Lord for the work of the U. S. Coal Testing plant at St. Louis.¹ A twenty-five burner Bunsen combustion furnace was used to heat a Bohemian or Jena glass combustion tube about 100 cm. long and 20 mm. outside diameter in which there were, beginning from the outlet end (where the products of combustion leave the tube): (1), a loose plug $1\frac{1}{2}$ cm. long formed by a spiral of copper gauze placed 6 cm. from the end; (2), 14 cm. filled with lumps of fused lead chromate; (3), a second copper gauze plug, (4), 35 cm. of the wire form of copper oxide; (5), a third copper gauze plug, after which was a space of 38-40 cm. at the inlet end in which was a spiral of copper gauze about 5 cm. long. The tube projected about 10 cm.

¹ U.S. Geol. Survey, Prof. Paper 48 (1906), p. 184.

beyond each end of the furnace and was closed at both ends by well fitting, single bored, rubber stoppers which were protected from the heat of the furnace by asbestos screens. Oxygen and air were supplied from gas holders and were purified by passing through a Traubers drying apparatus which consisted of a wash bottle containing strong sulphuric acid, another containing a one to one solution of caustic potash, and a 13" U tube the first limb of which was filled with granulated soda lime and the second with granulated calcium chloride; this purifying train was in duplicate so that oxygen could be passed through one half and air through the other. The two halves were connected by a T to a glass stop-cock tube, one end of which passed through the rubber stopper into the inlet end of the combustion tube.

The absorption train at the outlet end of the combustion tube consisted of a 6" Marchand U tube filled with calcium chloride to absorb moisture, and a Geissler or a Geissler-Wetzel potash bulb, with guard tube containing soda lime and calcium chloride, to absorb carbon dioxide. After the Marchand U tube had been filled with calcium chloride, the open limb was sealed off and a stream of carbon dioxide passed through it for an hour in order to convert any oxide present into carbonate; the carbon dioxide was swept out with dry air before the tube was used. One side tube was passed through the outlet cork of the combustion tube, a bulb between this and the limb of the U tube caught most of the water produced, and as this was shaken and boiled out of the bulb at the end of each experiment, one filling of calcium chloride (about 35 grams) lasted for a large number of determinations; the other side tube was connected with the potash bulb by rubber tubing, which was wired on during each experiment. The potash bulb was filled afresh for each experiment with a solution of two parts of caustic potash in three parts of water. The U tube and potash bulbs were fitted when not in use with end caps of rubber tubing with glass rod plugs, they were weighed before and after every experiment and were left at least a quarter of an hour in the balance case before each weighing; the caps of the tube or bulb were removed, the ends where the rubber caps had been, carefully wiped with a clean duster, and the whole brushed with a camel's hair brush just before they were put on the pan of the balance. Sometimes they were weighed alone and at other times each was weighed against a similar dummy tube or bulb on the other pan and the difference in weight recorded.

The absorption train was followed by a final guard tube of soda lime and calcium chloride which was connected to a Marriott bottle that supplied a constant head of suction. The suction was adjusted to be nearly but not quite sufficient to draw air through the whole apparatus, air or oxygen was then supplied to the purifying train under slight pressure so that it could pass through the whole apparatus, and as the interior of the combustion tube was under slight suction there was less danger of leaks than if it had been under pressure. When the absorption train was not in position the guard tube was used to protect the outlet end of the combustion tube.

Before any experiments were made with a combustion tube it was strongly heated and a stream of oxygen passed through it in order to burn out

any organic matter from the tube or its contents. The whole apparatus was also carefully tested for leaks.

In an actual experiment that part of the tube containing the copper oxide was heated to a bright red, with the exception of the first few centimetres which were left cool, the part containing the lead chromate was heated to a barely visible red. Meanwhile the calcium chloride tube and potash bulb of the absorption train were weighed and set aside, and a platinum or porcelain boat, which had been ignited and cooled, was weighed and about 0.2 gram of the sample to be analysed introduced into it as follows: the sample tube containing the coal was weighed and a suitable amount of coal poured out into the boat which was resting on a cork which had a groove cut to fit the boat and was covered with tin foil; the tube was at once recorked, the boat put into a desiccator and the tube then re-weighed, the difference in weight was the exact weight taken for analysis. When the combustion tube was properly heated the absorption train was connected up to the outlet end, the inlet cork was taken out, the copper spiral temporarily removed and placed on a clean watch glass, and the boat of coal introduced and pushed nearly up to the plug confining the copper oxide; the copper spiral was then put back and the cork replaced. A very slow current of oxygen was then caused to pass through the whole apparatus; the burners at the inlet end of the tube were now lit up, but until the copper spiral was at a bright red heat no heat was allowed near the boat. The most critical part of the experiment is in the gradual heating of the coal in the boat to drive off the volatile matter. This must be done very slowly otherwise methane and other hydrocarbons may escape unburnt from the tube; the heating was done by progressively lighting the burners under the boat, approaching it from both sides before any burners immediately underneath were lit, the flames were kept very low at first and then turned up little by little, and finally, when the flames were full up, the tiles for this part of the furnace were closed one by one to further increase the temperature. At no part of the experiment, if properly carried out, should there be more than a gentle succession of bubbles through the potash bulbs. When all the volatile matter had been driven off, the oxygen current was slightly increased and maintained until the coke left in the boat was completely burned: the progress of the combustion could be watched by observing the glow in the boat; this was regulated in intensity by means of the oxygen and was never allowed to become at all bright as there might be fusion of the ash. The oxygen was cut off some five or ten minutes after the combustion appeared to be completed, and air was then passed through until air only was left in the absorption train: each cubic centimetre of oxygen unreplaced by air in an absorption tube causes it to weigh about $1\frac{1}{3}$ tenths of a milligram too much. The air current was very gentle at first but was increased later; about a litre of air was drawn through in an hour. During the latter part of the experiment care was taken to see that any moisture which had condensed in the cool part of the tube by the outlet cork was driven on into the calcium chloride tube; if necessary that part was heated by means of a hot tile. The diffusion of water, etc., into the

inlet end of the tube past the copper spiral, which was intended to stop such diffusion, was always prevented if possible; but if water did condense there it also was driven forward by means of a hot tile.

At the end of the experiment the burners under the inlet end were turned out and the tiles opened; the absorption train was disconnected and the caps put on the tubes which were then put in the balance case to stand before weighing; and the boat was taken out and put in a desiccator ready to weigh in order to determine the weight of ash left.

The furnace was then ready for another determination, and if meanwhile a second set of absorption tubes had been prepared and weighed, and another boat of coal weighed, it was commenced at once.

From one to two hours were taken in bringing the furnace up to full heat after the boat was introduced, oxygen was passed through for about an hour longer at full heat, and then air was passed through for another hour to sweep out the oxygen. Two complete combustions with one furnace took as a rule eight or nine hours, but with two furnaces it did not take much longer for one operator to make four determinations.

An analysis of lignite was found to require great care in the initial heating; with coke or even anthracite this could be hurried.

W. Pollard, of the Geological Survey of England and Wales, recommends that the boat should rest on a strip of platinum foil in the combustion tube; "this prevents any chance of its sticking to the tube, and diminishes the chance of any copper oxide adhering to it."

The plugs and diffusion spiral are described as being spirals of copper gauze; it will, of course, be easily seen that in use the copper is rapidly oxidized and that after a few experiments they will be almost entirely copper oxide, although retaining their original shape.

The oxygen used was supplied by the Dominion Calcium Light Co., of Montreal. It was prepared, chiefly for medical use, by heating potassium chlorate. Blank experiments were made on sugar to test the purity of the oxygen and the accuracy of the apparatus before beginning the regular series.

The second modification of the general method of determination of carbon and hydrogen differed mainly from the above in the following points:—

(1.) The oxygen and air were passed through the apparatus under pressure, no suction was employed.

(2.) The absorption train consisted of (a) a 5" U tube packed with pumice stone soaked in concentrated sulphuric acid, after each experiment the tube was re-filled with acid and the excess poured off before the next experiment; (b) a U tube packed with small pieces of stick caustic potash; and (c) a guard tube of soda lime and calcium chloride.

(3.) The purifying train was modified to match the absorption train; the order was caustic potash solution, calcium chloride, soda lime, and, lastly, concentrated sulphuric acid at the furnace end of the train.

SULPHUR

Sulphur was determined in regular coal and coke samples by the Eschka method, and as a check on this, it was also determined in the rinsings from the bomb calorimeter; at first gravimetrically by precipitation as barium sulphate, but later volumetrically by the more rapid benzidine method. A few unimportant samples were treated by burning with sodium peroxide and afterwards precipitating the sulphur with barium chloride.

Eschka Process

The reagents required were: (1) Eschka mixture, composed of two parts by weight of light magnesium oxide and one part of sodium carbonate mixed well together. (2) A saturated solution of bromine water, made by putting bromine into a bottle of distilled water: more water can be added from time to time as long as there remains any liquid bromine in the bottom of the bottle. (3) Dilute hydrochloric acid, approximately five times normal, (5N HCl) prepared by diluting the pure concentrated acid with its own volume of water. (4) Half normal barium chloride solution, which is a solution containing 61 grams of the crystallized salt per litre.

The determinations were as a rule carried out in batches of five or six and in addition a blank experiment was made with each batch. About $1\frac{1}{2}$ grams of Eschka mixture were placed in a weighing bottle ($3'' \times 1\frac{1}{2}''$) and one gram of the sample added; the contents of the bottle were well mixed by shaking, and then placed in a No. 2 (50 c.c.) porcelain crucible the bottom of which had been lined with a little of the Eschka mixture. The weighing bottle was rinsed out with half a gram more of the Eschka mixture and the rinsings were spread as a covering layer over the contents of the crucible: the crucible was kept on a sheet of glazed paper whilst being filled so that anything spilt could be recovered. The crucible for the blank was filled with the same quantity of Eschka mixture but without any coal or coke. In order to save weighings, marks were kept on the weighing bottles to show the heights to which they were filled with $\frac{1}{2}$ gram and $1\frac{1}{2}$ grams of the Eschka mixture. When a batch of crucibles was ready it was put into a cold, gas muffle furnace. The muffle was heated up to a dull red heat—greater heat would cause objectionable sintering or even fusion of the charge—and kept at that heat for about two hours; this time was usually sufficient to burn off the coal (or coke) completely, after which the crucibles were taken out and allowed to cool. The contents of each crucible were transferred to a 350 c.c. casserole and the soluble matter thoroughly extracted with distilled water; to do this about 75 c.c. of water were put into the casserole which was then heated on a hot plate until the water boiled, when it was taken off, the contents allowed to settle, and the clear solution filtered through an 11 cm. filter (C.S. and S.No. 597) in a long stemmed funnel, into a 400 c.c. beaker; more water was then put into the casserole and the boiling, settling, and filtering process repeated two or three times; the residue was still further washed with hot water until

the total filtrate amounted to about 300 c.c. Ten c.c. of bromine water were added to the filtrate in order to oxidize any sulphide or sulphite to sulphate, and the solution was made acid by the addition of about 4 c.c. of the hydrochloric acid. The beaker was then heated on the hot plate and its contents kept very gently boiling until rendered colourless by the removal of the excess of bromine. The solution was allowed to cool slightly, 12 c.c. of hot barium chloride solution were added slowly from a pipette with a fine jet, the whole well stirred, and then left to stand in a warm place for at least an hour. The barium sulphate precipitate was filtered through a 9 cm. filter (C. S. and S. No. 589, white ribbon) carefully folded to fit a 2 $\frac{1}{4}$ " funnel: the clear solution was poured off through the filter, hot distilled water added to the precipitate, which after stirring was allowed to settle, and the clear liquid poured through the filter; this process was repeated a number of times. The precipitate was then washed on to the filter: after all that could be moved by the jet of the wash bottle was on the filter, the beaker and stirring rod were thoroughly cleaned by alternately rubbing with a rubber tipped glass rod and rinsing on to the filter with water from the wash bottle. The precipitate on the filter was then washed with hot water until the water passing through no longer showed milkiness when dilute silver nitrate solution was added. The filter containing the barium sulphate was then folded up and put in a weighed platinum crucible, this was heated very gently until its contents were dry, rather more strongly until the filter paper was completely charred, and then to a bright red heat until ten or fifteen minutes after the carbon of the paper had been burned off; this ignition in an open crucible would ensure the complete re-oxidation to sulphate, of any barium sulphide which might have been formed by the reducing action of the carbon of the paper on the barium sulphate. The crucible was then cooled and weighed; the increase in weight was the weight of the barium sulphate plus the filter ash. In the blank experiment the weight found was that of the barium sulphate produced from sulphur in the reagents or absorbed from the gas of the muffle furnace, together with the filter ash. The weight found in the blank experiment was subtracted from that found in the other determinations in the same batch. The weight of sulphur corresponding to this net weight of barium sulphate was calculated by multiplying the latter by the factor 0.1374 (log. = $\bar{1}$.1378); from the weight of sulphur thus found in the coal, the percentage was easily calculated.

All weighing bottles, crucibles, casseroles, funnels, and beakers were numbered 1, 2, etc., or B, for the blank, and a record kept of the number of the sample corresponding to each number; great care was taken in all the transferences, filterings, etc., to see that everything was kept in order. Whenever possible the vessels were kept covered with watch glasses. Filtering was usually done on a special stand of adjustable height, made to hold seven funnels; but it was found that time could be saved without loss of accuracy by filtering the barium sulphate precipitate through a funnel passing through a cork in the neck of a tubulated bell jar in which a suction of about 6" of water was maintained by a water pump and a safety valve, although each determination was then carried on singly at this stage instead of the

seven being filtered simultaneously. In order to prevent any possible passage of the barium sulphate precipitate through the pores of the filters, the latter were prepared for use after they were put in the funnels by pouring a small quantity of paper pulp into them, filling up with water, and allowing to drain. The paper pulp was made by cutting up a few of the No. 589 filter papers and shaking them in a large bottle with a considerable quantity of water until thoroughly disintegrated.

Sulphur in Calorimeter Rinsings

The rinsings from the bomb calorimeter, when ready for the sulphur determinations to be made on them, were either neutral or alkaline, as they had been previously titrated with sodium carbonate to determine their acidity. They were filtered into a beaker and, in the gravimetric method, they were made acid with 1 c.c. of hydrochloric acid (5 Normal) and heated, hot barium chloride solution was added and the determination completed as described above.

For the volumetric determination by the benzidine method the following solutions were required (cf. F. Raschig. *The Chemical Engineer* Vol. IV. No. 2. June 1906, p. 76): (1) Benzidine chloride; 40 grams of benzidine were well rubbed up with 40 c.c. of water, the pulp brought with $\frac{3}{4}$ litre of water into a litre flask, 50 c.c. of concentrated hydrochloric acid (specific gravity 1.19) added, water added to the mark and the whole thoroughly mixed; a brown solution was produced which was filtered if necessary. (2) A 1 per cent solution of hydroxylamine hydrochloride. (3) A standard solution of caustic potash, approximately tenth normal, the strength of which is expressed as the weight of sulphur, in the form of sulphuric acid, equivalent to each cubic centimetre. (4) Phenolphthalein solution made by dissolving 1 gram of the solid in 100 c.c. of 86 per cent alcohol.

The cold filtered calorimeter rinsings, which would have a volume of from 300 to 400 c.c., were made acid in the benzidine method with a few drops of dilute nitric acid; 10 c.c. of the hydroxylamine hydrochloride solution were added and 25 c.c. of benzidine solution diluted to 100 c.c. with water; the solution was stirred and the beaker set aside for 15 to 30 minutes to allow the silky, flaky precipitate of benzidine sulphate to settle. The precipitate was filtered off, with suction, through two 5.5 cm. filter papers in a Büchner funnel of a size to just allow the filter papers to lie flat on the filter disc. The suction was stopped just before the funnel was quite dry and any precipitate left in the beaker was washed out on to the funnel with some of the filtrate from this or a previous experiment: as the precipitate has very little tendency to stick to the glass a couple of rapid rinsings suffice to completely clean the beaker. The suction was again put on, and as soon as the last of the solution had passed through the filter, the precipitate was twice washed with a few cubic centimetres of cold water, and the suction again stopped when the precipitate was just dry. The precipitate is perceptibly soluble even in cold water so that very little should be used and this drawn

through at once. Keeping the suction on too long causes the precipitate to contract to a dry, silvery skin which is only slowly attacked by the caustic potash in the subsequent titration.

The precipitate and paper were then transferred to a 200 c.c. Erlenmeyer flask, the funnel was wiped out with a little paper and any precipitate still left was rinsed into the flask with hot water; a little phenolphthalein was added, the flask closed with a rubber cork and violently shaken until the filter paper was thoroughly disintegrated. The cork and the walls were then rinsed down, and the solution in the flask titrated with the standard caustic potash solution; it was kept hot whilst the caustic potash was being added, and the end point was only reached when the pink colour produced was permanent on boiling.

The number of cubic centimetres of caustic potash solution required, multiplied by the weight of sulphur to which each cubic centimetre is equivalent, gave the weight of sulphur in the coal taken, from which the percentage could be calculated.

It is advantageous to employ three wash bottles for the above determination: one for cold water, one for hot, and one to contain some of the filtrate. One filtration can be carried out whilst the previously filtered precipitate is being heated and titrated in the conical flask.

By the benzidine method as above it is possible to determine the sulphur in a batch of seven calorimeter rinsings in three or four hours. The method appears to give consistent results. Five pairs of readings by the barium chloride and the benzidine methods gave the following differences: 0.11, 0.06, 0.02, 0.04, and 0.11, the latter method always gave the higher result. The percentage of sulphur determined in the calorimeter rinsings was always found to be slightly less than by the Eschka process; this was probably largely due to the sulphuric acid produced in the calorimeter attacking the lead gasket of the bomb; if the washing out of the calorimeter were delayed, or a fresh gasket employed, the difference was found to be greater than usual.

NITROGEN

Nitrogen was determined in all regular coal samples by the Kjeldahl method. In this method a definite weight of coal is dissolved in concentrated sulphuric acid with the addition of a little mercury, the nitrogen in the coal is thus converted into ammonium sulphate; the mercury is then precipitated as mercury sulphide, the solution made alkaline with caustic soda, and the ammonia thus set free distilled over into a definite quantity of standard sulphuric acid, part of which it neutralizes; the quantity of acid neutralized by the ammonia is determined by titrating the excess with standard caustic soda solution, and from this the weight of nitrogen in the coal can be calculated.

The following solutions were employed: (1) Concentrated caustic soda solution, 1,200 grams of soda to 2,000 c.c. of water. (2) Potassium sulphide solution, 40 grams per litre. (3) Cochineal solution, prepared by digesting

1 part of powdered cochineal with 10 parts of 25 per cent alcohol and then filtering. (4) Approximately decinormal (0.1 N) sulphuric acid solution; and (5) approximately 0.1 N caustic soda solution, the exact strength of which had been determined, and was recorded as the weight of nitrogen (as ammonia) to which each cubic centimetre of the solution was equivalent.

One gram of the coal was weighed out into a 200 c.c. Kjeldahl flask—a pear shaped flask with long neck—a drop of clean mercury weighing about 0.7 gram was added from a burette, the glass stop cock of which had its bore partially filled with plaster of Paris so that it delivered the correct amount each complete revolution; 25 c.c. of concentrated sulphuric acid were also added, and the flask then heated to boiling over a small flame (without the interposition of wire gauze) in a fume cupboard. The mixture was kept gently boiling until the fumes of sulphur trioxide were no longer evolved; 10 grams of potassium sulphate were then added in order to raise the boiling point of the mixture, and the whole kept boiling until the solution was practically colourless: the average time taken to get the coal completely dissolved was about 1½ hours, but with high ash coals the product was always rather dark in colour, however long the boiling was continued. The contents of the flask were then allowed to cool, sufficient water was added to completely dissolve any salts that had crystallized out, and the solution thoroughly rinsed out into a 750 c.c. Erlenmeyer flask; 25 c.c. of the potassium sulphide solution were then added to precipitate the dissolved mercury, some fragments of unglazed porcelain and a small lump of paraffin wax were added to prevent bumping and frothing, and, when everything was in readiness to proceed with the distillation, 150 c.c. of the concentrated caustic soda solution were added and the flask at once closed by the cork through which the delivery tube passed to the absorption flask (see Plate LV). The flask was then heated and the contents kept briskly boiling until one-half had boiled away. A large bulb splash head on the delivery tube caught any alkali splashed from the boiling liquid and returned it to the distillation flask, the steam and ammonia passed through and along the tube which was bent round and down through a two-holed cork into the absorption flask: the stem of a bulb tube filled with glass beads passed through the other hole in the cork. Before the distillation was begun 25 c.c. of the 0.1 N sulphuric acid were run down through the beads into the absorption flask and a little cochineal solution also poured on the beads. The end of the delivery tube came to within about half an inch of the surface of the acid in the flask which was kept cool by being immersed in a water bath; any ammonia which escaped absorption by the acid in the flask was caught by the acid moistening the lower beads, and the cochineal always showed that the upper layer of the beads at any rate, remained acid. When the distillation was finished the end of the delivery tube and also the tube of beads were thoroughly rinsed into the absorption flask, and the excess of acid left in that flask was then titrated with the 0.1 N caustic soda; the cochineal present served as indicator for the titration.

From time to time, whenever any fresh reagent or solution was employed,

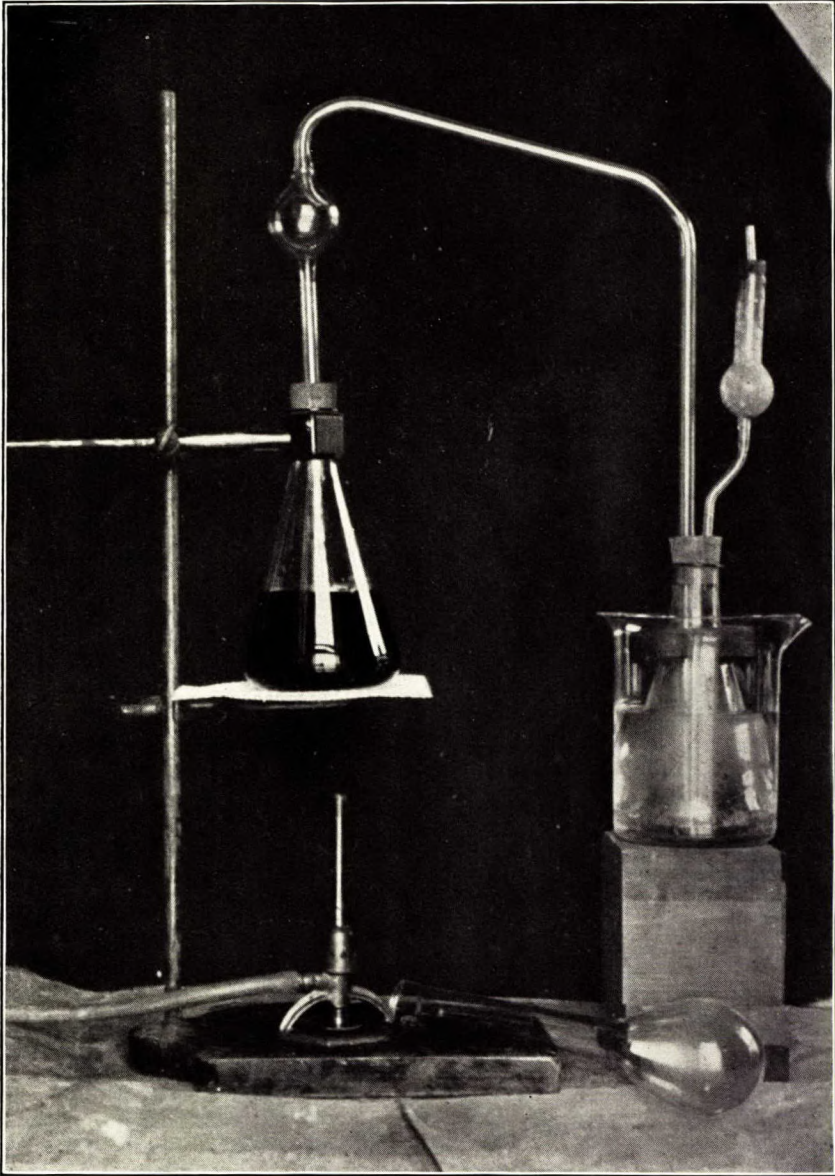

Kjeldahl nitrogen distillation apparatus. Chemical Laboratory, Department of Mining and Ore Dressing, McGill University.

a blank experiment was carried out; the number of cubic centimetres of caustic soda required in any determination subtracted from the number required in the blank experiment in which the same solutions were employed, gave the number of cubic centimetres corresponding to the ammonia produced from the nitrogen in the coal taken; this number multiplied by the weight of nitrogen to which one cubic centimetre of the caustic soda was equivalent gave the weight of nitrogen in the coal taken, from which the percentage could be calculated.

OXYGEN

As no method has yet been devised for the direct determination of oxygen in coal, the sum of the determined percentages of carbon, hydrogen, sulphur, nitrogen, and ash in the sample was subtracted from 100 and the result reported as the percentage of oxygen present.

This method throws upon the oxygen the sum of the errors of all the other determinations, not only errors of manipulation, etc., but also errors inherent to the methods employed. Various possible errors will be discussed more fully later, but as an example, a very common one may be given here. When coal contains iron pyrites (FeS_2), the sulphur is determined as such, but when the coal is burnt for the determination of ash, the pyrites becomes oxidized to ferric oxide, by absorption of atmospheric oxygen, so that the recorded weight of ash includes, besides the iron, the oxygen of the ferric oxide which was not in the coal at all; the reported percentage of ash in the coal will, therefore, be too great by this amount, and the percentage of oxygen, in consequence, too small.

Various possible corrections have been suggested; but it was felt to be advisable to keep to the simple method given above, rather than to adopt doubtful methods of correction. If it is clearly understood that "ash per cent" and "oxygen per cent" are conventional terms, representing results obtained in a certain standard way, rather than percentages of definite constituents of the original sample, then the chemical analysis of a coal loses little of its value as a guide to the nature of the coal, by reason of errors of the above character. Corrections are apt to introduce a personal element, which is undesirable, and also to give rise to an unwarranted feeling of accuracy of result.

The simple method adopted has also the great advantage that it is the one in most general use, in spite of the following recommendation made by the Committee on Coal Analysis of the American Chemical Society¹:—

"The method to be used in calculating the oxygen of the coal presents, perhaps, the question of greatest difficulty. If we could be sure that all of the sulphur is present in the form of pyrites, and that this is converted into ferric oxide in the ash, the oxygen should be found by subtracting from 100, the sum of carbon, hydrogen, nitrogen, ash, and $\frac{2}{3}$ of the sulphur. This is probably the safest rule which can be given for general use, and especially for coals high in sulphur. The operator should, however, satisfy himself as

¹ Jour. Am. Chem. Soc., Vol. XXI, p. 1129, 1899.

to whether the ash is practically free from sulphates, and, if possible, whether the sulphur is mainly in the form of pyrites. If necessary, the rule should be modified, in particular cases, accordingly."

CALORIFIC VALUE OF SOLID FUELS

The calorific value of solid fuels was determined by burning a weighed quantity of the fuel in an atmosphere of compressed oxygen inside a bomb immersed in water, and noting the rise in temperature of the water: the rise in temperature multiplied by the number of heat units required to raise the bomb, water, containing vessel, etc., one degree (a number which is known as the water equivalent of the calorimeter), gave the number of heat units evolved by the complete combustion of the sample taken.

The bomb calorimeter used was an improved form of the Mahler instrument, made by Fritz Köhler of Leipzig. It consists of the following principal parts: (A) The bomb with accessories, pressure gauge, and conducting tubes. (B) The calorimeter with three heat protecting jackets, mechanical stirrer, and Beckmann thermometer.

The bomb, shown in section in Fig. 51, is a steel vessel of 275 c.c. capacity, tested to 300 atmospheres, with a screwed-on brass cover. The bomb is lined with enamel, the cover is plated on the inside with platinum to a thickness of 0.2 mm., and the outside of both bomb and cover, and all the metal parts of the calorimeter, are nickel plated. There are two openings through the cover into the bomb $S K$ and $S' K'$, these can be closed by the needle valves c and c_1 : c is the inlet valve through which oxygen is admitted to the bomb, the oxygen passes down through the platinum tube R to the bottom of the bomb, so that all risk of the contents of the crucible C being blown out by a rush of gas is obviated; c_1 is the outlet valve, it was usual to leave this open for a short time when the bomb was being charged with oxygen, in order that the air in the bomb might be swept out. In the centre of the cover is an insulated standard with a binding screw, this standard is connected with the platinum rod d inside the bomb; the standard and rod are so arranged that, although they are electrically insulated from the rest of the bomb, no gas can escape around them. In the preliminary experiments trouble was caused by the heat of the combustion inside the bomb burning the electric insulation in spite of the protection of a mica washer; the mica washer was, later, protected and kept in position tightly against the cover by means of a heavy platinum washer screwed on the platinum rod. The platinum crucible or capsule C has a sleeve which slips on the tube R and holds the crucible in the desired position. The coal or other fuel in the crucible C was fired by a small fuse of fine iron wire passing from Z to Z_1 , and having one or two loops in it which were arranged to touch the coal, the fuse was electrically heated by a current through wires connected to the two binding screws E and F , the binding screw E was connected to one end of the wire fuse through the standard and rod insulated from the rest of the cover, and the binding screw F was connected to the other end of the fuse through the valve C , the cover, and the tube R ; the current was taken from

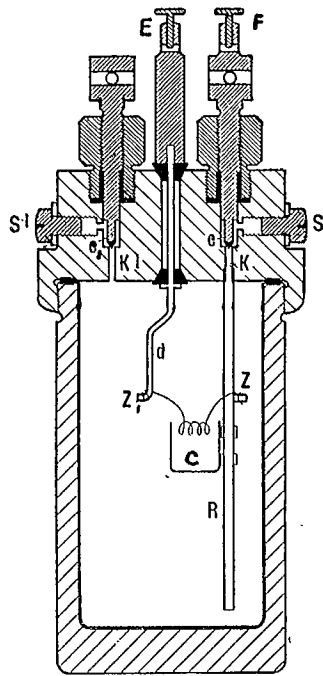

Fig. 51. Vertical section, K  hler calorimeter bomb.

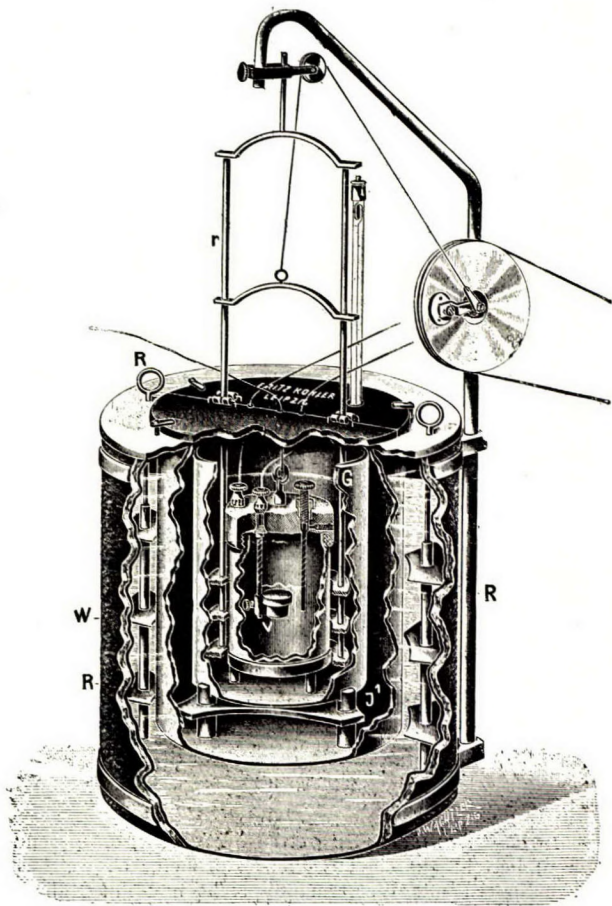

Fig. 52. Vertical section, Koehler calorimeter.

a 110 volt supply and passed through two or three 32 candle power lamps—or their equivalent—arranged in parallel; this gave a current of 2·3 amperes which sufficed to almost instantly heat the wire fuse up to the temperature at which it caught fire and burned in the oxygen, and thus stopped the current. When the bomb was in the calorimeter the openings *S* and *S*¹ were closed with screw plugs. The junction between the bomb and its cover is made gas tight by means of a lead gasket or washer; care had to be taken to keep this clean and in good condition, and from time to time the gasket and the different screws were smeared with a trace of vaseline. The bomb has three pegs on the bottom, not shown in the figure, which fit into three holes in a special stand screwed down to the top of a table (see Plate LVI); when the bomb is placed on this stand the cover can be screwed down by means of a special double-ended spanner which fits over it. It is very undesirable to use excessive force when closing either the cover or the needle valves; if care is taken to keep these clean and in good condition, no great force is required.

The pressure gauge is graduated in kilograms per square centimetre (kg./cm².) —1 atmosphere=1·033 kg./cm². The gauge was connected on the one side to a high pressure oxygen cylinder, and on the other it could be connected to the bomb, by capillary copper tubes fitted at the ends with suitable screw connectors.

The calorimeter is a nickel plated, brass vessel of about 5 litres capacity, with a stand inside, supported on three non-heat-conducting legs, on which the bomb can be placed. The calorimeter vessel itself also rests on three insulating legs in a much larger double-walled vessel; there is an air space between the calorimeter and the outer vessel, which latter has water between its double walls, is covered with a layer of felt, is closed with a vulcanite lid, and stands on three hard rubber legs. The general arrangement is shown in Fig. 52 where the stirrer in the outer jacket and the stirrer in the calorimeter can be clearly seen; the latter was raised and allowed to drop by being connected, by a piece of string passing over a pulley, to a crank driven by an electric motor: the rods of the stirrer pass between anti-friction rollers on the vulcanite lid, which allow the stirrer to move freely up and down, but prevent it from touching the walls of the calorimeter or bomb; each rod is made in two pieces connected by vulcanite sleeves to prevent the escape of heat along the rods. A small thermometer records the temperature of the water in the outer jacket, and a Beckmann thermometer, which is supported at a fixed height by a clamp (not shown), records the temperature of the water in the calorimeter vessel.

The Beckmann thermometer is made of Jena glass, and has a scale which reads from $-0\cdot25^{\circ}$ to $+6\cdot20^{\circ}$: each degree is divided into hundredths and the total length of scale is 24·6 c.m., so that with the reading lense, attached by a clip carrier to the thermometer, it is possible to read to the thousandth of a degree. The thermometer has a certificate from the Physikalisch-Technische Reichsanstalt (dated Aug. 21, 1906), which shows that the following corrections have to be applied:—

- (a). Calibration corrections in $\frac{1}{1000}$ of a degree at $0^\circ \dots 0$, at $1^\circ \dots 0$, at $2^\circ \dots + 2$, at $3^\circ \dots + 3$, at $4^\circ \dots -18$, at $5^\circ \dots -6$, at $6^\circ \dots 0$.
- (b). Corrections for the mercury in the top bulb, etc., for different settings of the thermometer.

TABLE XLV
Recorded Temperature of Water in Calorimeter Vessel.

Setting of thermometer.	Mean temperature of outside portion of thermometer	Value of scale.
When 0° on scale corresponds to $\dots 0^\circ\text{C}$.	15°C .	$1^\circ\text{B.} = 0.999^\circ\text{C}$.
When 0° on scale corresponds to $\dots 10^\circ\text{C}$.	17°C .	$1^\circ\text{B.} = 1.004^\circ\text{C}$.
When 0° on scale corresponds to $\dots 20^\circ\text{C}$.	20°C .	$1^\circ\text{B.} = 1.008^\circ\text{C}$.

For intermediate temperatures and settings proportional corrections were made. As the calibration corrections above 3° (Beckmann) are rather serious, the upper half of the scale was avoided. When the thermometer was in use a small electric buzzer was clamped on the top; the vibration prevented the mercury from sticking in the capillary and moving jerkily in consequence.

The briquetting press supplied with the calorimeter was modified so that it could make a larger briquette in a shorter time; the coal briquettes made were 6 mm. diameter and averaged such a length that four or five weighed one gram. It was found possible to briquette every coal sample examined, but the anthracite coals and some of the lignites required to be ground very finely, and to be compressed as much as was possible with the small press.

The water put in the calorimeter vessel was measured and not weighed. The measuring vessel used was a large bottle having a cork cemented in the neck, through which passed an inlet tube for air and a delivery tube for water, the bottle was filled to a mark on the tubes half an inch above the cork, and when being emptied it was always drained for about the same time; it delivered, under these conditions, at 15°C . 3549 grams, at 16°C . 3548 grams, at 17°C . 3548 grams, at 18°C . 3547 grams, and at 19°C . 3546 grams of water.

The method of carrying out a determination was as follows: the temperatures of the room and of the water in the outer jacket of the calorimeter were adjusted, if necessary, to be within 2 or 3 degrees of each other, and the temperature of about four litres of water which had been put in a flask was adjusted to be about 1 degree cooler than the jacket water: if the room temperature was greater than the jacket temperature, the flask of water would be made slightly less than one degree cooler than the jacket, and vice versa; the Beckmann thermometer was also re-set, if necessary, so that the temperature of the water would register on the lower part of the scale. As a general rule the water temperature alone would need to be adjusted. A piece of iron fuse wire was cut about 10 cm. long and weighed, a loop was made in the middle (round a piece of glass rod), and the two ends twisted round Z and Z₁. The crucible, previously ignited and cooled, was weighed, about a gram of the sample in the form of briquettes was introduced;

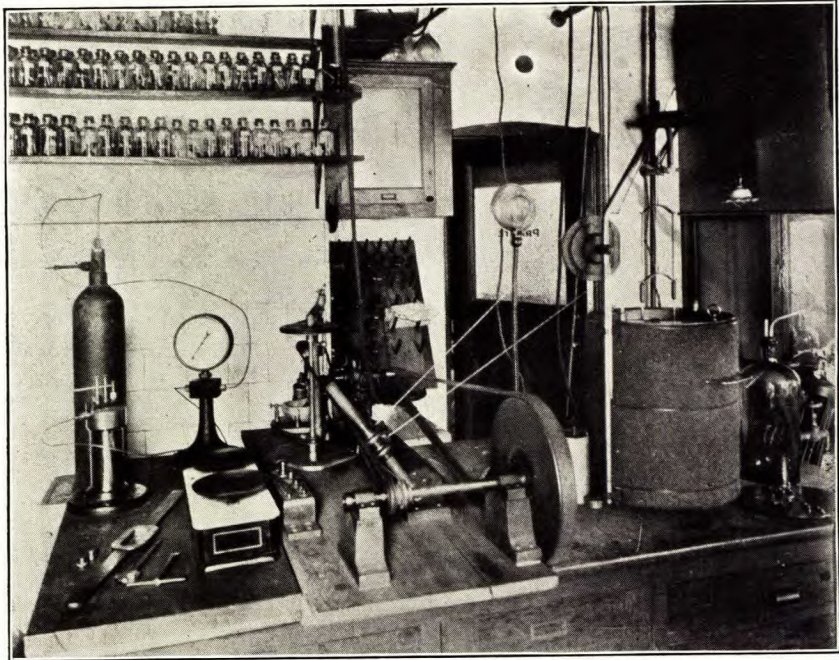

Köehler bomb calorimeter: general view. Department of Mining and Ore Dressing, McGill University.

it was then re-weighed and fixed to the platinum tube of the bomb in such a position that the loop of the wire fuse touched one or more briquettes. When the crucible and fuse were in position the cover was put on the bomb and screwed tight, the oxygen supply tube was connected to S, and, with the valves *c* and *c*₁ open, the valve of the oxygen cylinder was opened a little; after enough oxygen had been admitted to drive most of the air from the bomb the outlet valve was closed; when the pressure in the bomb rose to 22 kg/cm², as registered by the pressure gauge, the oxygen cylinder was closed, the inlet valve closed, the oxygen cylinder supply tube disconnected, and the two plugs S and S' put in; the bomb was then put into the calorimeter and two insulated copper wires, connected to the firing switch at one end, were connected to the binding screws on the bomb at the other end. Meanwhile the measuring bottle had been filled with water from the flask by means of a siphon; this water was then run into the calorimeter, the bomb was thus immersed except for the tops of the standard and the valve spindles. The lid was then put on the calorimeter, the Beckmann thermometer put in position, and the stirrer set in motion. About five minutes later the buzzer was started on the Beckmann thermometer, and thereafter readings were taken every minute to determine the rate at which the temperature of the water in the calorimeter was rising. If the rate of increase was found to be steady the firing switch was turned on after the sixth reading, and turned off again as soon as the lamps went out showing that the fuse had burned; if, however, the rise was not steady the readings were continued until it became so before the fuse was fired. For the first two minutes after firing readings were taken every half minute, and afterwards every minute until the expiration of five minutes after the temperature attained to a steady rate of change; this final steady period was usually reached five minutes after the firing. The first reading of this period was taken as the final temperature when calculating the rise of temperature of the calorimeter during the combustion period. The calorimeter was then taken out of the jacket, the bomb was taken out of the calorimeter, dried, opened, and thoroughly rinsed out with hot water into a beaker, and any fuse wire left unburnt was dried and weighed; any readily detachable ash was removed from the crucible which was ignited and put in a desiccator to cool, the calorimeter water was returned to the flask, the different parts of the bomb and calorimeter were dried, and the apparatus was then ready for another determination. The rinsings from the calorimeter were titrated with standard sodium carbonate solution, methyl orange was used as indicator. One hour was sufficient for a complete determination, excluding briquetting the coal and making the necessary calculations.

The actual rise of temperature recorded during the combustion period—that is from the time of firing at the end of the first steady period to the beginning of the second steady period—required to be corrected for heat transmitted to or from the calorimeter by radiation or conduction from outside; this radiation correction was calculated from the observed rates of change of temperature during the steady periods, it was kept as low as possible by

the suitable preliminary adjustment of the temperatures of the water and jacket, etc., so that heat gained during the earlier part of the combustion period was neutralized by heat lost during the later part, when the temperature of the calorimeter had risen above that of its surroundings. The recorded temperatures had also to be corrected for errors of calibration of the thermometer, and the corrected rise of temperature converted to the equivalent degrees Centigrade by means of corrections found from the thermometer certificate. The corrected rise in temperature, expressed in Centigrade degrees, multiplied by the water equivalent of the calorimeter system, gives the total heat, in calories, generated by the combustion in the bomb; in order to obtain the true calorific value of the fuel, this had to be corrected for accessory combustions; i.e., heat is given out by the iron wire fuse in burning, nitrogen in the bomb is liable to be burned to nitric acid, and sulphur in the fuel, which normally, when burning in air, burns to sulphur dioxide, burns in the compressed oxygen in the bomb to sulphur trioxide which combines with water present to form sulphuric acid, thus giving out an extra quantity of heat which cannot be legitimately included in the calorific value of the fuel. The above accessory heats have, therefore, to be subtracted from the total heat, and the net heat thus found, divided by the weight, in grams, of fuel taken, in order to obtain the calorific value of the fuel in calories per gram.

The methods employed for recording the readings and calculating the result of a determination are illustrated by the following example, to which explanatory notes have been added.:-

Method of Recording the Readings and Calculations of Determinations.

Dec. 7, 1907. Coal No. 1 (dry). Determination 1, Batch 1.
 Crucible + coal = 5.2290 wire (1) = 0.0106
 " = 4.1808 " (2) = 0.0000

Coal No. 1 taken = 1.0482 grams. Fuse wire burned = 0.0106 grams.

Bomb: air swept out; charged to 25 kg/cm²; slight leak.
 Temperatures: water = 16°C.; jacket = 16.88°C.; room = 17.4°C.
 Beckmann setting: 16.88°C. = 1.32°B., see note (a).

Time	Temperature readings.			
11.44 a.m.	0.453°B	} -15(h).	(f) 2.262 + 0.002 = 2.264	
45	0.455		(g) 0.462 + 0.000 = 0.462	
46	0.456			1.802
47	0.458			(h) 0.002
48	0.459			
49	0.460			(i) 1.804 × 1.006
50	0.462			11
		(d) - 15	(e) - 6	
½	0.98	8	1	1.815°C.
51	1.98	+ 4	+ 3	
½	2.23	8	4	
52	2.26	8	8	
53	2.26	8	8	
54	2.262	8	8	
55	2.262	} + 8 (c)	8	
56	2.261		+ 0.0024	
57	2.260			
58	2.259			
59	2.258	(j) Total heat evolved: 1.815 × 4065 = 7378		
12.00 noon	2.258	(k) Fe: 1.06 × 17 = 18		
01 p.m.	2.257	HNO ₃ : = 17		
		H ₂ SO ₄ : 1.048 × 1.4 × 13 = 19		54
				<u>7324</u>

Rinsings to beaker 1, 17c.c. required
 (of the sodium carbonate solution).
 All seemed well.

$$\frac{7324}{1.0482} = 6988 \text{ calories per gram.}$$

Explanatory Notes.

(a). Zero on the Beckmann scale, therefore, represents 15.5°C . and the factor to convert degrees Beckmann into degrees Centigrade is, therefore, from the thermometer certificate, 1.006.

(b). This is the average fall of temperature per minute during the initial period due to heat lost to (or gained from) the outside; it is expressed in ten-thousandths of a degree on the Beckmann scale, and, as the temperature was actually rising, it is negative in value.

(c) This is the average fall of temperature per minute during the final period in 0.0001°B .

(d). This column gives the *rate* in 0.0001°B . per minute, at which the calorimeter would get cooler, at each time the thermometer was read during the combustion period, on account of gain or loss of heat from or to the outside. The assumption is made, in making this calculation, that the change in the rate of gain or loss is proportional to the change in temperature—thus at the mean temperature of the first period (0.46°) the rate was -15 per minute, at the mean temperature of the final period (2.26°) the rate was $+8$, thus a change of 1.80° caused a change of rate from -15 to $+8$, that is, a total change of rate of 23 ; the rise in temperature from 0.46° to 0.98° (the recorded temperature at $11.50\frac{1}{2}$ a.m., half a minute after firing) is 0.52° , so the change in rate would be $23 \times \frac{0.52}{1.80} = 7$; therefore, at $11.50\frac{1}{2}$ a.m. the rate of loss in temperature, due to gain or loss of heat from or to the outside, is $-15 + 7$ that is -8 . The other numbers in column (d) are similarly calculated.

(e). This column gives the calculated *loss* in temperature of the calorimeter, during each interval of the combustion period, due to gain or loss of heat from or to the outside. The method of calculation is as follows: the rate of loss at 11.50 a.m., for example, was -15 , half a minute later it was -8 , the mean rate per minute during the period was $-11\frac{1}{2}$, but as the period was only half a minute the actual loss for the period was half this, that is $-5\frac{1}{2}$ or approximately -6 . The algebraic sum of the numbers in this column gives the calculated amount by which the temperature of the calorimeter, at the end of the combustion period, is lower than it would have been if no heat had passed from or to the outside during the period: this is known as the radiation correction.

(f). This is the final temperature of the combustion period, which lasted from 11.50 to 11.55 a.m.; 0.002 is added, being the calibration correction of the thermometer at that temperature.

(g). This is the temperature at 11.50 a.m., when the firing switch was turned on; the calibration correction in this case is zero. Subtracting (g) from (f) gives the actual rise in temperature.

(h). This is the radiation correction, calculated as above, which is added to correct for heat lost.

(i). The net rise in temperature thus found is converted into degrees Centigrade by multiplying by 1.006.

(j). The total heat generated in the bomb in calories is calculated by multiplying the net rise in degrees Centigrade by the water equivalent of the calorimeter system (4065 in this case).

(k). The thermal values given by different authorities for the reactions involved in accessory combustions, vary considerably; the corrections were made as follows:—

Iron.—The number of centigrams burned was multiplied by 17.

Nitric acid: the rinsings from the calorimeter were titrated with sodium carbonate solution containing 3.706 grams of the anhydrous salt per litre, and the correction was made of one for every cubic centimetre of the solution required (the assumption was here made that all the acidity was due to nitric acid).

Sulphuric acid: a further correction was required for that portion of the acidity due to sulphuric acid; this was made by multiplying the weight of coal taken by the percentage of sulphur it contained (in the above sample 1.4 per cent) and multiplying the product by 13.

The above corrections (which are in calories) subtracted from the total heat, gives the total net heat from the combustion of the coal under normal conditions; this divided by the weight of coal taken gives the calorific value of the coal in calories per gram, which can be converted into British Thermal Units per pound by multiplying by 1.8.

All determinations of calorific value were made in duplicate, and only those checks that differed by less than 25 calories were considered satisfactory; when the combustion was complete, and no other obvious source of error noted, the disagreement was rarely as large as 25. In the earlier determinations about a gram of coal was taken; it was afterwards found that fewer failures and better agreement resulted if the weight taken was varied with the quality of the fuel so that a rise of from 1.5° to 1.8° C. was obtained.

The water equivalent of the calorimeter system was determined (a) by burning in it substances of known calorific value; (b) by weighing the parts and multiplying the weight of each constituent material of the system by its specific heat; (c) by adding a weighed amount of hot water of known temperature and observing the rise in temperature of the calorimeter; and (d) by generating electrically a known quantity of heat inside the bomb and observing the rise in temperature.

For the first of these methods naphthalene, anthracene, benzoic acid, hippuric acid, and canesugar were employed, but it was found to be more difficult to obtain consistent results with these substances than with coal, and the method was abandoned.

The second method involved estimating the weights of nickel plating, lining enamel, etc., also the specific heats of the steel, brass, etc., from their probable composition; part of the calorimeter vessel, stirrer, thermometer, etc., are not immersed in the water and so are not heated by the combustion to the same extent, their water equivalent was, therefore, calculated separately, and only one-third of it added to the water equivalent found for the rest of the system. As the water required to immerse the bomb constitutes over 85 per cent of the water equivalent of the whole system, the possible errors resulting in the calculation of the water equivalent of the remainder of the system, due to errors in the above estimations and correction, can only be a small percentage error of the water equivalent of the whole.

For the third method a special vessel was made from which the hot water was delivered into the calorimeter; it was of copper with a delivery tube at the bottom closed by a spring valve actuated from the top, was provided with a stirrer and thermometer, and was enclosed in an outer jacket to minimize radiation losses. The vessel was made of a size to allow it to stand on the lid of the calorimeter without interfering with the stirrer of the latter, and was arranged so that the delivery tube, which went through the hole in the lid through which one of the firing wires usually passed, should deliver the water without splashing into the calorimeter vessel. The calorimeter was set up as usual except that no coal or fuse wire were put in the bomb, and that a weighed amount of water was removed from the measuring vessel before its contents were poured into the calorimeter, so that when the hot water (from 300 to 400 c.c.) was run in, the final level of water in the calorimeter should be the same as usual. The amount of hot water run in was determined by weighing the containing vessel and accessories before and after. Cooling corrections were applied to determine the mean temperature of the water run in, and also, as usual, to the readings taken of the calorimeter. Two experimenters were required to carry out this determination.

In the electrical method of standardization, the iron wire fuse in the bomb was replaced by a coil of platinum wire, the length and thickness of which was varied in different experiments. The apparatus was set up as usual, but the current was passed through an ammeter, and the voltage across the terminals of the bomb was determined by a voltmeter. Readings of the calorimeter temperatures were taken every minute during the initial and final steady periods, and also during the heating period; readings of the ammeter and voltmeter were taken twice every minute during the twenty to thirty minutes the current was passing. The current was varied in different experiments from about four to nine amperes, and the voltage from thirteen to seven; these were, however, maintained as steady as possible during each experiment. It was found necessary to varnish the insulated standard of the bomb to prevent electrolysis of the water between this and the rest of the bomb, and it was found advantageous to have compressed oxygen in the bomb to accelerate the passage of heat from the heating coil to the walls of the bomb. The ammeter and the two voltmeters employed were standardized in the Physical Laboratories of McGill University, under

the direction of Prof. H. T. Barnes, and with the assistance of Dr. R. W. Boyle, and a table of corrections drawn up. If T is the time in seconds during which the current was passed, A the mean corrected value of the current in amperes, V the mean corrected value of the current in volts, R the corrected rise in temperature of the calorimeter in Centigrade degrees, and W the water equivalent of the calorimeter system, then the value of the latter is given by the equation:—

$$W = \frac{A \times V \times T}{R \times 4.188}$$

The weighing of the parts of the calorimeter gave as the water equivalent of the whole system—including the weight of water taken at the usual temperature employed, and also the oxygen in the bomb—the value of 4064 grams. The hot water method gave, as the mean of nine determinations varying from 4041 to 4083, the result of 4066 grams. The electrical method gave, in seven determinations, results varying from 4055 to 4070 with a mean of 4062 grams. It was decided to adopt the value of 4065 grams.

A new and heavier bomb was used for all determinations after Nov. 1908, the water equivalent of the system was then similarly determined as 4150 grams.

Fuller details of the method of use of a bomb calorimeter can be found in a paper by Atwater and Snell.¹

CALORIFIC VALUE OF ASH FREE COAL

Ash free or ash and sulphur free coal do not exist, so that the calorific value of a coal calculated on either basis has a theoretical significance only, and has, probably, little commercial value. It was, however, thought worth while to calculate the calorific value of the ash free coal, in order to assist in the comparison of the different raw and washed samples from the same seam. The method of calculation consisted in multiplying the determined calorific value by 100 and dividing by 100 minus the percentage of ash in the sample.

CALORIFIC VALUE CALCULATED FROM ANALYSIS OF COAL

A large number of different methods have been suggested for calculating the calorific value of coal from its analysis; some of these calculations are based on the proximate analysis, and others on the ultimate analysis of the coal. The results from the proximate analyses often show wide divergences from the determined calorific values; the results from the ultimate analyses are more reliable, but, as a calorimeter test is more rapidly and easily made than an ultimate analysis, and as few laboratories equipped to make ultimate analyses are not also equipped with at least a Parr or other simple form of calorimeter, if not with a bomb calorimeter, there seems to be little gained by making such calculations. The calculation was, however, made for all coal samples of which ultimate analyses had been made, and the

¹Jour. Am. Chem. Soc., Vol. XXV, No. 7, July 1903, pp. 659-699.

results are given in the tabular statement. The formula adopted was that of Dulong, recommended by the Committee on Coal Analysis of the American Chemical Society (1899), which is the best known, though possibly not the most accurate:—

$8080 C + 34460 (H - \frac{1}{8}O) + 2250 S =$ calorific value in calories per gram—where C is the weight of carbon in one gram of the sample, H the weight of hydrogen, O that of oxygen, and S that of sulphur.

FUEL RATIO

The fuel ratio of a coal, that is, the number obtained by dividing the percentage of fixed carbon in the sample by the percentage of volatile matter, gives considerable insight into the character of the coal; the higher the ratio the more the coal has changed from its original vegetable nature. The ratio varied in the samples examined from three-fourths in a lignite, to nearly seven, in an anthracite. The determination of volatile matter in coal can not be classed as an accurate determination, and any error causes an equal, but opposite, error in the fixed carbon, and, therefore, a larger error in the ratio of the two; no significance, therefore, should be attached to small variations in the fuel ratio, but, as stated above, the ratio does give a general idea of the nature of the coal.

D. B. Dowling of the Canadian Geological Survey, has suggested a modified form of this ratio, which he calls the "Split Volatile" ratio.¹ He proposes a classification of coals for commercial purposes depending on the ratio, fixed carbon plus one half the volatile matter, divided by moisture plus one half the volatile matter; the analyses being made on an air dry sample. The claim is made that this ratio varies more in accordance with the heating value of the coal than does the ordinary fuel ratio.

CARBON HYDROGEN RATIO

Carbon and hydrogen are capable of very exact determination in coal, so that the ratio obtained by dividing the percentage of carbon present by the percentage of hydrogen, is one which can be determined with considerable accuracy. M. R. Campbell, in the report of the U. S. A. Coal Testing Plant at St. Louis, recommends the carbon-hydrogen ratio as the most satisfactory basis for the classification of coals; it should, however, be carefully noted that his figures are from analyses of air-dried coal, whilst the analyses and ratios given in this report are of dry coal. Drying the sample before analysis has the effect of raising the carbon-hydrogen ratio, this makes the most serious difference in the case of the lignites; the ratio could be easily re-calculated to the air-dry basis if desired.

For a further discussion of the above and other methods for the classification of coals from the chemical analysis, see the article by M. R. Campbell, referred to above.²

¹Report No. 1035 of the Geological Survey Branch of the Department of Mines, Canada, p. 43. See also Canadian Mining Journal, Vol. XXIX, p. 143, 1908.

²(U. S. Geol. Survey, Prof. Paper 48 (1906), pp. 156-173.)

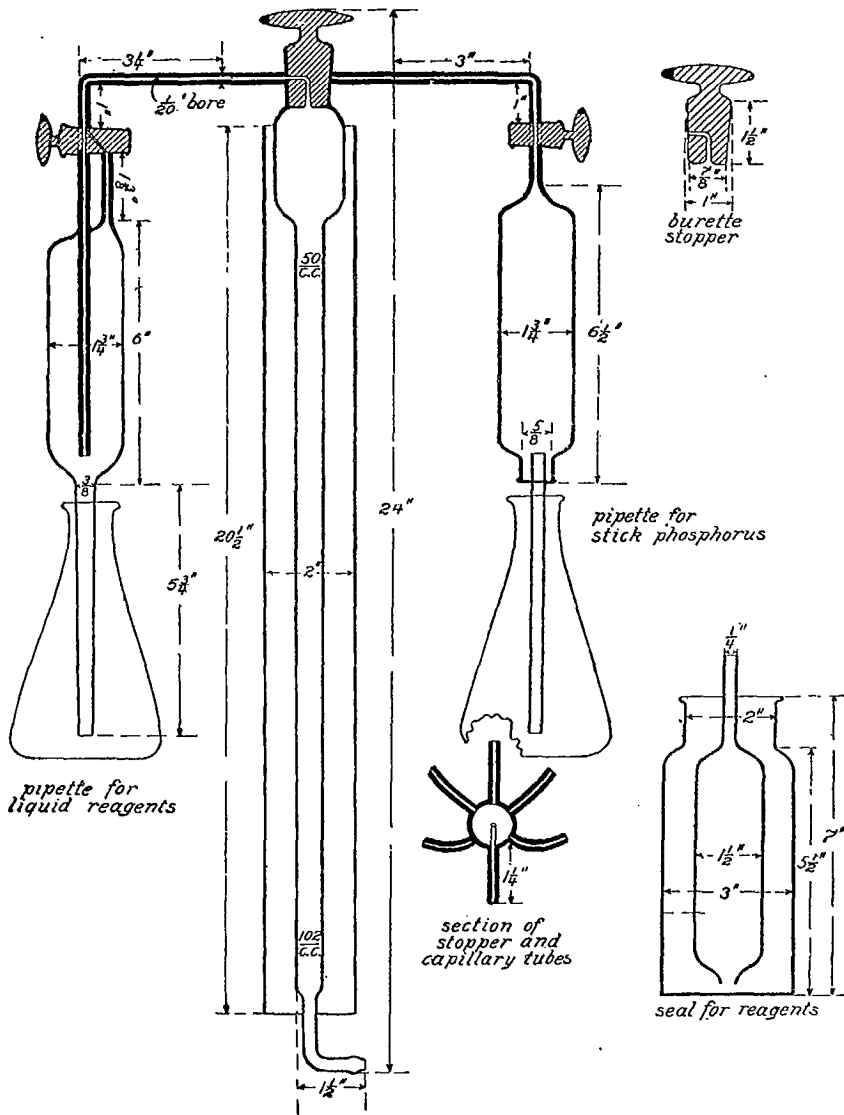
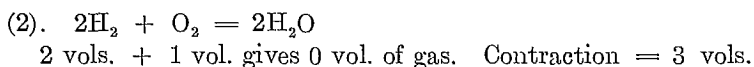
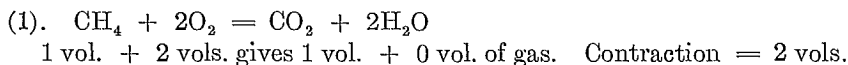

Fig. 53. Section of glass parts of Randall and Barnhart gas analysing apparatus.

GAS ANALYSIS

The constituents which are usually determined in the samples of producer gas, coke oven gas, etc., are: carbon dioxide, unsaturated hydrocarbons (of these ethylene is most important, and their total percentage, there being no ready means for determining them separately, is generally reported as the percentage of ethylene), oxygen, carbon monoxide, saturated hydrocarbons (usually almost entirely methane), hydrogen, and nitrogen. In flue gas samples, carbon dioxide, oxygen, carbon monoxide, and nitrogen are the only constituents determined. The first four gases mentioned above are determined by absorbing them successively by means of suitable reagents: a definite volume of gas (100 c.c. as a rule), measured under atmospheric pressure, is passed from the measuring vessel into an absorption pipette containing the first reagent to be employed; after sufficient time has elapsed for complete absorption the gas is brought back into the measuring vessel, and the reduction of volume at atmospheric pressure gives the volume of the constituent gas absorbed by that reagent. After the four absorptions have been completed the gas residue may contain methane, hydrogen, and nitrogen; a definite amount of this is taken, mixed with an excess of oxygen or air, and exploded in a vessel over mercury by means of an electric spark between two platinum points; the reduction in the volume of the gas, due to the explosion, is measured, and then the volume of carbon dioxide produced is determined by absorption in caustic potash. The reactions in the explosion are:—



from which the following formulæ are deduced:—

Volume of methane = volume of carbon dioxide produced.

Volume of hydrogen = $\frac{2}{3}$ (volume of contraction less twice volume of carbon dioxide produced).

From the volumes of methane and hydrogen found in the quantity of gas residue taken, their percentages in the original sample can easily be calculated. If the gas is not rich enough to explode when mixed with oxygen, a little electrolytic gas is added to the mixture. Electrolytic gas is formed by electrolysing acidulated water, and is composed of hydrogen and oxygen in the proportions required to form water; as the electrolytic gas returns entirely to water when exploded, the addition of the gas makes no difference to the final volume after the explosion. The percentage of nitrogen is calculated by subtracting from 100 the sum of the percentages of the other constituents.

Gas Analysis with the Orsat-Muncke Apparatus.

The Orsat apparatus is too well known for any description of it to be necessary. It was only used for flue gas analyses during the summer of 1907. The absorbents employed were: (1) caustic potash to absorb carbon dioxide; (2) an alkaline solution of pyrogallol (pyrogallic acid) to absorb oxygen; and finally, an acid solution of cuprous chloride to absorb carbon monoxide; the two latter solutions required frequent renewals. The pyrogallol solution was made by dissolving 7 grams of the salt in 18 c.c. of water and placing the solution in the absorption pipette, a solution of 145 grams of caustic potash in 95 c.c. of water was then added, and the pipette at once closed.

Gas Analysis with Randall and Barnhart Apparatus.

This apparatus was described by E. Barnhart in the *Electrochemical and Metallurgical Industry*, Vol. V (1907), p. 350. Fig. 53 shows the section of all the glass parts of the apparatus, and Plate LVII is from a photograph of the apparatus when set up.

The measuring burette is of rather more than 100 c.c. capacity; the narrow part is graduated in $\frac{1}{10}$ c.c. from 102 c.c. at the bottom to 50 c.c. just below the wide part, and has a white back with a blue strip to facilitate accurate reading. The bottom of the burette terminates in a narrow tube for a rubber connexion with a levelling bottle, and the upper end in a wide neck which forms the casing for a six-way tap stopper. On the outer circumference of this casing are six capillary tubes $1\frac{1}{2}$ " long, which each communicate with the burette when the stopper is in the proper position. Six pipettes can thus, if necessary, be in turn directly connected with the burette, so eliminating the long header capillary of the Orsat apparatus, and the necessity, as with the Hempel apparatus, for changing the pipettes during the process of analysis. The six-way stopper was kept well lubricated and never gave any trouble. The pipettes for liquid reagents are of the type in which the gas is forced to pass through the reagent; the pipette proper terminates in a narrow tube which passes through a double-bored rubber stopper into a 300 c.c. Erlenmeyer flask, which acts as a support for the pipette and a reservoir for the reagent, a second tube through the rubber stopper of the flask can, if necessary, be connected to a very simple water seal standing on the base-board of the apparatus. When gas was being passed into a pipette, the tap was first turned for an instant into such a position that the liquid was driven out of both capillaries leading into the pipette, the tap was then given half a turn and the gas thus forced to pass through the longer capillary and rise up through the liquid.

The following reagents were employed as absorbents: (1) caustic potash solution, to absorb carbon dioxide; prepared by dissolving one part by weight of caustic potash in two parts of water. (2) Bromine water, to absorb unsaturated hydrocarbons, such as ethylene; a saturated solution of bromine in water was used, sometimes about 5 per cent of potassium bromide was added to reduce the vapour pressure of the bromine; the gas



Randall and Barnhart gas analysing apparatus: general view. Department of Mining and Ore Dressing, McGill University.

was always returned to the potash pipette to remove bromine vapour, before remeasuring. (3) Sticks of yellow phosphorus to remove oxygen; these are made by melting yellow phosphorus under water and sucking it up into a piece of glass tubing of about $\frac{1}{8}$ " bore, then cooling it, and forcing out of the tube by means of a glass rod; very great care must be taken in performing the above operation to avoid all risk of fire or poisoning. The phosphorus pipette was painted to protect the phosphorus from the action of light. (4) Ammoniacal cuprous chloride solution to absorb carbon monoxide; 15 grams of ammonium chloride were dissolved in 60 c.c. of water in the reservoir flask, 57 grams of cuprous chloride were added, and concentrated ammonia added with frequent shaking until the copper salt was dissolved, water was then added to fill the flask. This solution was always protected from the air by a water seal, the air in the pipette and in the seal was displaced by nitrogen or hydrogen when refilling the pipette. (5) Acid cuprous chloride to absorb any carbon monoxide not previously absorbed; 16 grams of copper oxide were dissolved by warming with 200 c.c. of concentrated hydrochloric acid, 100 c.c. of water were then added and 26 grams or more of copper in the form of turnings, wire, or gauze, and the whole heated and caused to gently simmer until colourless; the solution was then cooled at once and transferred to a water sealed pipette without air being allowed to come in contact with it: copper wire was kept in the reservoir flask of the pipette, and the solution was in this way kept colourless.

The above apparatus was used for nearly all producer gas samples, and for all the flue gas samples after the first summer.

The actual analysis was carried out as follows: the pipettes were each filled with their reagent, or with water in the case of the phosphorus pipette, to a mark just below the stop-cock, and the burette and its front capillary tube were completely filled with water. The aspirator bottle containing the sample (see page 127) was placed on a stand in front of the apparatus, (the stand and sample bottle are shown on the left in Plate LVII); the rubber tube of the sample bottle was filled with water from the spring clip upwards, to displace the air from it, and was then connected to the front capillary tube of the burette. By suitably manipulating the various cocks and levelling bottles, approximately 102 c.c. of the gas sample were introduced into the burette, and the sample bottle and stand were removed. After the water had been allowed to drain from the walls of the burette for one minute, the levelling bottle was raised and the gas compressed to exactly 100 c.c., the rubber tubing at the bottom of the burette was then pinched with the finger and thumb to prevent change in volume, whilst the stop-cock was turned to bring the gas in the burette into momentary connexion with the outside air. As the gas was at more than atmospheric pressure, some would escape leaving 100 c.c. at atmospheric pressure in the burette. By suitably turning the stop-cocks and raising the levelling bottle, the gas was driven over into the caustic potash pipette, where it was left, with occasional shaking, for one minute. The gas was then returned to the burette and the reagent

brought back to its original level in the pipette. After the water had again been allowed to drain down in the burette for one minute, the gas was brought to atmospheric pressure, by raising or lowering the levelling bottle until the level of the water in it was the same as that in the burette, and its new volume read: the contraction was taken as the volume of carbon dioxide present in the sample. The gas was then transferred to the second pipette, and so on.

The gas was left for one minute in the potash solution, one minute in the bromine, three minutes in the phosphorus, three minutes in the first cuprous chloride solution and two minutes in the second, and it was always left a minute in the burette before its volume was read. The above times for absorption were, however, varied slightly according to the freshness and activity of the reagent, and the probable percentage of the constituent to be absorbed.

The use of ammoniacal cuprous chloride followed by the acid solution gave very satisfactory results: the ammoniacal solution has great capacity for absorption, and the acid solution, which has a vapour pressure too low to cause appreciable error, has normally only very small traces of gas to absorb, so that both reagents will last for a large number of determinations.

Determinations of hydrogen and methane, in the gas residue left after the above absorptions, were made by explosion over mercury, usually in a Hempel pipette which could be temporarily attached to the front capillary connexion of the burette; but, occasionally, the gas left after removing carbon monoxide was transferred to a test tube over mercury, and the analysis completed over mercury in the Bone and Wheeler apparatus. Electrolytic gas, prepared by electrolysing a dilute solution of sulphuric acid, was used to enrich the gas taken for explosion; the percentages of hydrogen and methane in producer gas are not, as a rule, high enough to enable the explosion to be made without such addition. The use of the Bone and Wheeler apparatus for the determination of hydrogen and methane, and the Randall and Barnhart apparatus for the determination of the other constituents of the gas, was found to be a very satisfactory combination, and rapid analyses could thus be made with reasonable accuracy.

Water is not entirely satisfactory as the confining liquid for gas analysis, as some gases dissolve in it to an appreciable extent; but the use of a mercury apparatus throughout would have involved extra work which was not thought to be commensurate with the increased accuracy to be attained. Although it is possible to use water with reasonable accuracy during the absorptions, it cannot be used during the explosion, as the carbon dioxide produced, at the high pressure developed by the explosion, is dissolved to a considerable extent by the water; and a small loss of carbon dioxide occasions a large error in the result.

The following example shows the method of calculating the result of a gas analysis with the Randall and Barnhart apparatus and Hempel explosion pipette:—

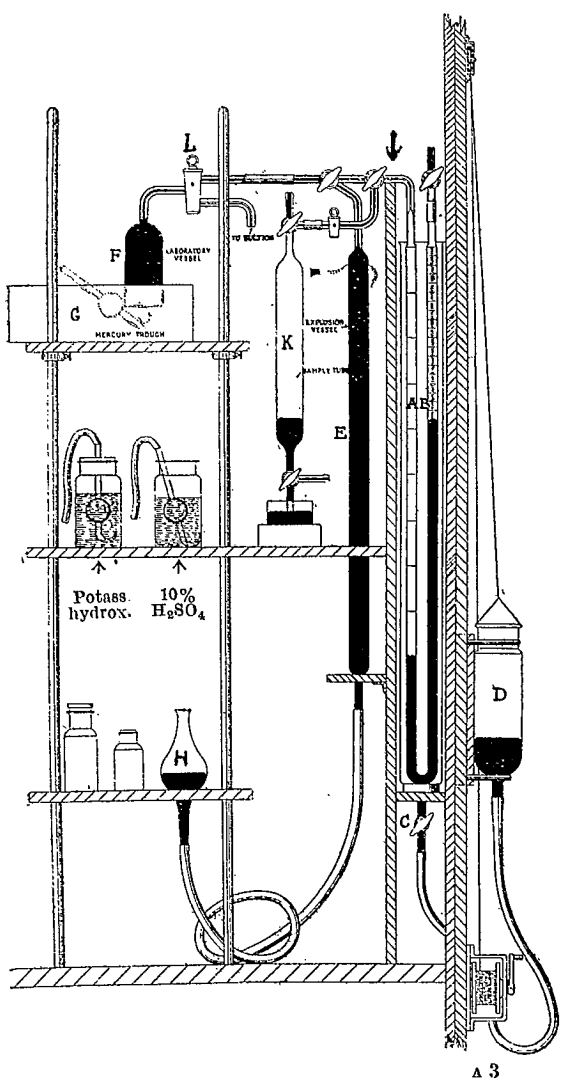

Fig. 54. Diagram of Bone and Wheeler gas analysing apparatus.

TABLE XLVI

Analysis of Producer Gas, with Randall and Barnhart Apparatus.

Gas taken (Producer gas)	= 100.0 cc.			
After potash	= 90.2 "	contraction = 9.8 cc.	Carbon dioxide =	9.8%
After bromine	= 89.7 "	" = 0.5 "	Ethylene =	0.5
After phosphorus	= 89.1 "	" = 0.6 "	Oxygen =	0.6
After cuprous chloride	= 80.2 "	" = 8.9 "	Carbon monoxide =	8.9
Volume of gas residue taken for explosion	= 22.2 "			
After adding air	= 68.3 "			
After adding electrolytic gas	= (79)			
After explosion	= 62.0 "	contraction = 6.3 "		
After potash	= 61.0 "	" = 1.0 "	Methane =	(a) 3.6
Contraction due to hydrogen = 6.3 - (2 × 1.0)		" = 4.3 "	Hydrogen =	(b) 10.4
By difference			Nitrogen =	66.2
				100.0

Note (a) $1.0 \times \frac{80.2}{22.2} = 3.6$

Note (b) $4.3 \times \frac{2}{3} \times \frac{80.2}{22.2} = 10.4$

Gas Analysis with Bone and Wheeler Gas Analysis Apparatus.

This apparatus was described by W. A. Bone and R. V. Wheeler in the Journal of the Society of Chemical Industry, Vol. XXVII, Jan. 15, 1908, p. 10. It was used for all coke oven gas samples, for a few producer gas samples and some miscellaneous gas samples, and also, as described above, to determine the methane and hydrogen in some producer gas samples after the other constituents had been removed in the Randall and Barnhart apparatus.

Fig. 54 gives a diagrammatic representation of the apparatus, and Plates LVIII and LIX show the apparatus as set up in the laboratory. The apparatus comprises, essentially, three parts, viz.: (1) a water-jacketed combination of measuring and pressure tubes, A and B, communicating, through the glass tap, C, with the mercury reservoir, D; (2) an absorption, or laboratory, vessel, F, standing over mercury in a mahogany trough, G; (3) an explosion tube, E, fitted with firing wires, and connected with a separate mercury reservoir, H. All the connexions between A, E, and F, are of capillary bore throughout, with suitable glass taps wherever necessary. The diagram also shows how connexion is made between the measuring tube, A, and the special sampling tube, K, whenever the latter is employed for the introduction of the sample under examination; in one photograph a small pipette containing sticks of phosphorus is shown in the place of the sampling tube K; an unsuccessful attempt was made to replace pyrogallol by phosphorus for the absorption of oxygen in this apparatus, but the power of the phosphorus to absorb oxygen rapidly diminished when mercury was used, instead of water, as the confining liquid.

Gas samples were generally introduced into the apparatus from an ordinary hard glass test-tube, under the wide, open end of the absorption vessel, F, which had been previously filled with mercury. Plate LX shows

the special rack in which gas samples were stored over mercury, in test-tubes standing in flat porcelain crucibles; the base of the stand had raised sides to prevent loss of mercury.

Before commencing an analysis, the whole of the apparatus, including all connexions between A, E, and F, was completely filled with mercury, and all subsequent operations were conducted over mercury.

The various parts of the apparatus are mounted on a wood stand of oak, with four vertical steel rods supporting the shelf upon which the mercury trough, G, rests; the same rods also carry two other shelves for reagent bottles. The mercury reservoir, D, can be raised or lowered (to the ground level, if required), in its wooden carrier, by means of a pulley with ratchet wheel and catgut cord. The whole apparatus stands in a wooden tray 2'-4" × 1'-6" with raised sides.

The salient features of the working of the apparatus are as follows:—

(1). The principle of measurement employed is that of the measurement of the pressure of the gas (in mm. of mercury) at constant volume. For this purpose the gas is brought to a certain constant volume mark in the measuring tube, A, (by suitable manipulation of the mercury reservoir D and the tap C) and its pressure read off on the pressure tube, B. There are a series of such constant volume marks on A, coinciding in level with each hundred mm. mark on the pressure tube B, so that the actual pressure of the gas is given by subtracting from the pressure reading the numbers 0, 100, or 200, etc., according to the particular constant volume mark selected for the analysis. The tubes A and B are made in one piece and are surrounded by a water jacket, their inner surfaces are kept moist with very dilute sulphuric acid (1 in 20) as a precaution against the accidental fouling of the measuring tube with alkalis: it is obvious that the wetting of A and B with the same liquid eliminates the influence of water vapour upon the gas measurements, the various pressures representing those of the dry gas under examination. The tap closing the upper end of the pressure tube is connected with the latter by means of stout rubber pressure tubing, a device which gives a perfectly tight joint with sufficient elasticity to prevent fracture in case the mercury in B is inadvertently allowed to run up the tube with unusual velocity; the tap in question also allows the vacuum to be easily re-made in B whenever necessary. The advantages of this mode of measurement over the more usual method of determining the volume under atmospheric pressure are twofold: (a), it allows of the use of smaller volumes of gas, for an analysis—thus from 5 to 10 c.c. of gas can be made to have a pressure of about 100 mm., according to the particular volume mark selected, and this pressure can easily be read off to within 0.2 mm. without employing a telescope (readings are best made by means of a light placed behind the tube a little below the surface of the mercury); (b), the measurements are independent of the barometric pressure and at the same time are unaffected by tension of aqueous vapour.

(2). The length of the pressure tube, B, (about 700 mm.) amply provides for the proper dilution of the explosive mixture in an explosion analysis, even in the case of a rich gas such as coal gas.

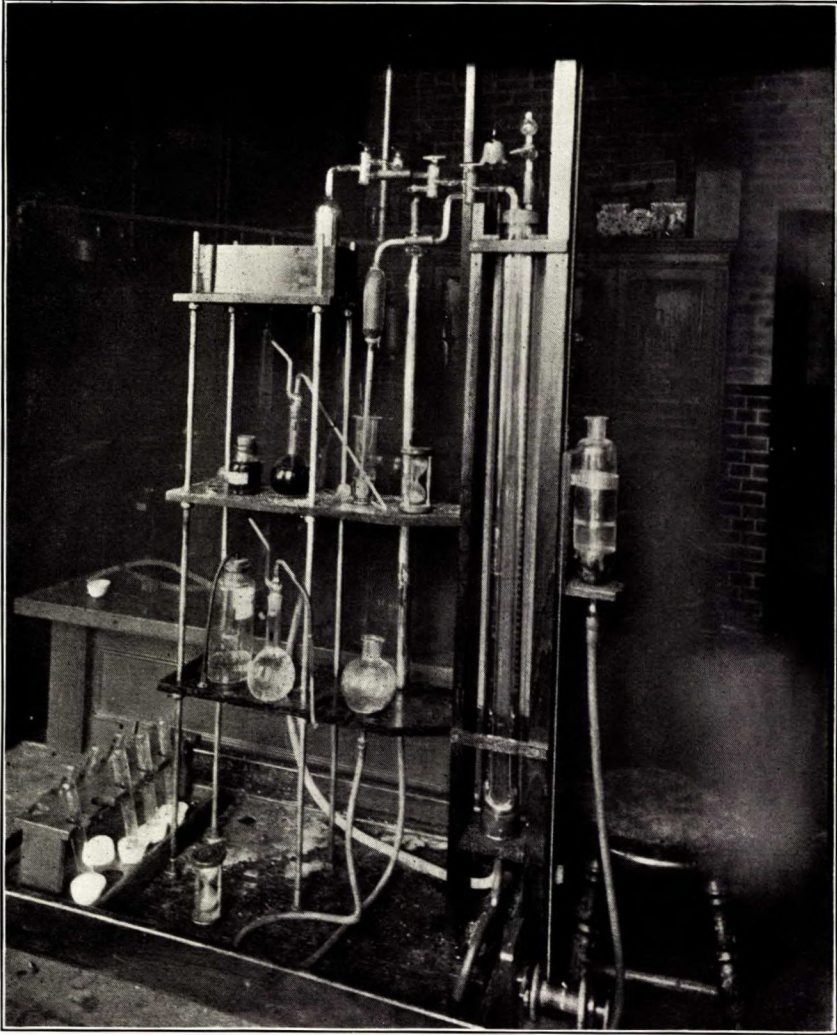

Bone and Wheeler gas analysing apparatus: general view. Department of Mining and Ore Dressing, McGill University.

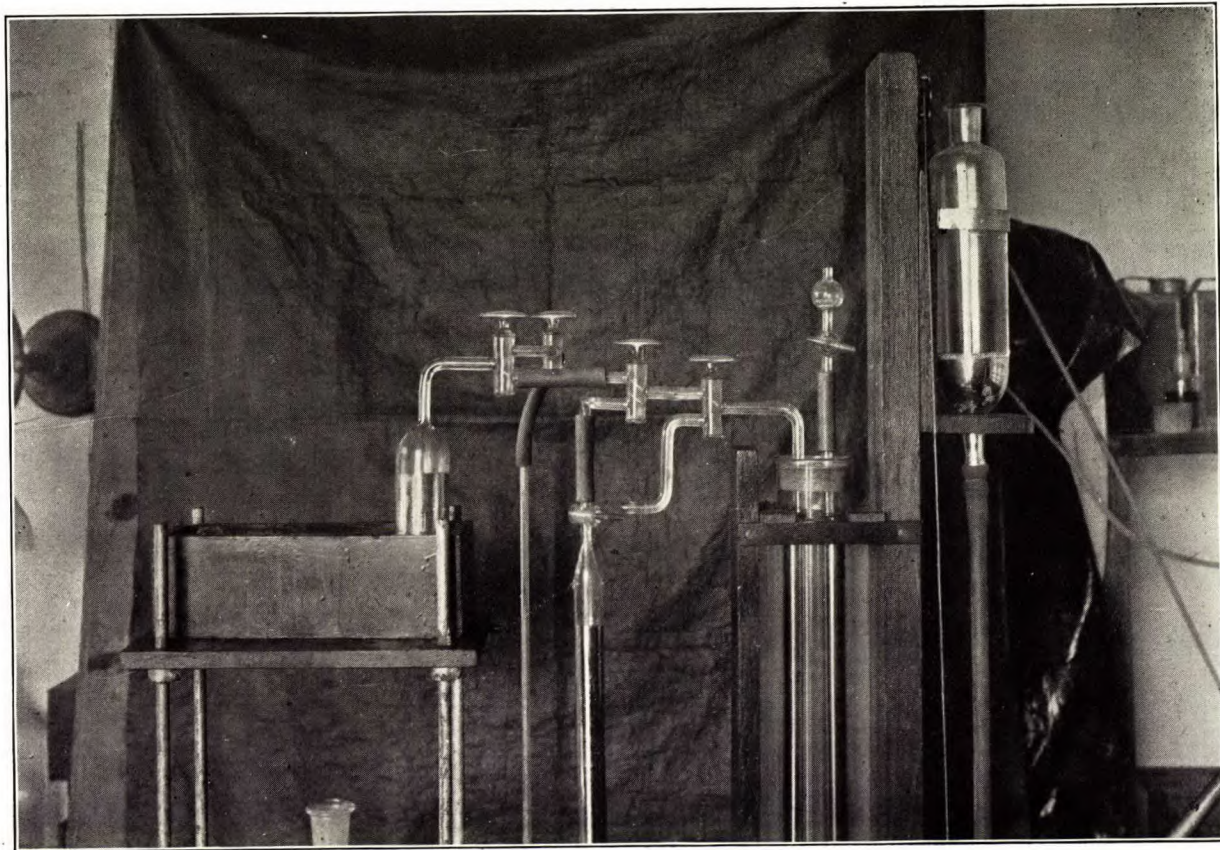

Bone and Wheeler gas analysing apparatus: details. Department of Mining and Ore Dressing, McGill University.

(3). The arrangements for the various absorptions are simple. Instead of using a number of large absorption vessels each containing a particular reagent, which is used unchanged many times over in successive analyses, all the absorptions are carried out over mercury in the one absorption vessel, F, in each case with a comparatively small volume of the particular reagent, which is always used fresh and is at once discarded after use.

To facilitate the introduction of the various reagents, and the rinsing out of the absorption vessel with water or dilute sulphuric acid *in situ* between each successive reagent, the wide, open end of the vessel is immersed in the mercury in the trough, G, whilst the top terminates in a capillary three-way tap, L. One of the parallel branches of this tap communicates, through a stout rubber joint, with the measuring vessel, A, and the other with a large exhausted bottle which serves to catch the discarded reagent and any mercury which also passes out. The bottle is re-exhausted from time to time by means of a water jet suction pump.

From 2 to 10 c.c. of the particular reagent to be used are introduced into the absorption vessel (previously filled with mercury) by means of a pipette with a curved jet, from below the surface of the mercury in the trough. Any bubble of air accidentally introduced with the reagent can be got rid of by cautiously opening the branch of the tap, L, leading to the above-mentioned, exhausted bottle. The gas can now be brought from the measuring vessel to the "laboratory" or absorption vessel F, and shaken with a previously introduced reagent. When the absorption is complete the gas is passed back to the measuring vessel, the tap L is turned as soon as the reagent reaches it so that the reagent passes out into the exhausted bottle; the laboratory vessel is then rinsed out with dilute acid and the rinsings also withdrawn, the tap L is then cautiously turned to connect the laboratory vessel with the measuring tube and the cleaned mercury allowed to flow from the laboratory vessel along the connecting tubes towards A until it reaches the point indicated by the arrow, the tap immediately behind this point is then closed, the gas brought to its original constant volume mark in the measuring tube, and the new pressure read: the difference between the new and the old pressures is a measure of the volume of gas absorbed by the particular reagent. A fresh reagent can now be introduced into the laboratory vessel and the process repeated. The oxygen and electrolytic gas required for the explosion are also introduced into the apparatus through the laboratory vessel.

The reagents, etc., employed were as follows: (1) Caustic potash: 1 part by weight dissolved in 2 parts of water. (2) Pyrogallol: about 2 c.c. of a solution, made by dissolving 1 part by weight of the salt in 4 parts of water, were introduced into the laboratory vessel, and then four times as much of the above caustic potash solution also introduced; the pyrogallol keeps better acid so that it was only mixed with alkali when actually required; an excess of potash is added to prevent the pyrogallol evolving carbon monoxide, but even so a gas should never be left more than ten minutes over this reagent. (3) Bromine: a solution of bromine in 10 per cent potassium bromide was employed; for gases containing only small quantities of unsaturated hydro-

carbons a saturated water solution to which potassium bromide was afterwards added was found to be sufficiently strong. As this reagent attacks the mercury slightly, the gas was never left more than five minutes over it, the vessel was rinsed out afterwards, first with caustic potash solution and then with 5 per cent sulphuric acid, and the gas was brought back into the laboratory vessel and treated with caustic potash to remove bromine vapour before it was remeasured in the measuring vessel. (4) Cuprous chloride: the gas was treated twice with ammoniacal cuprous chloride, prepared as described under the Randall and Barnhart apparatus. An ammoniacal solution of cuprous chloride, with a negligible vapour tension of ammonia, can also be prepared by suspending 75 grams of cuprous chloride in a solution of 15 grams of ammonium chloride in 300 c.c. of water, ammonia gas is then passed into the solution (kept out of contact with the air) until, after shaking the bottle, the solution smells of ammonia when the cork is released; an hour or more will be required to saturate—excess should be avoided; 10 to 20 grams more of cuprous chloride are then added, the solution well shaken, and stored in a well stoppered bottle.

The whole of the gas left, after treating with the above reagents, was used for the explosion, it was mixed with excess of oxygen and the volume measured, about 4 c.c. electrolytic gas was added if necessary, the gas passed into the explosion tube, E, fired by a spark from an induction coil, returned to the measuring tube, remeasured, treated with potash in the laboratory vessel, and again remeasured; the calculations were made as already described. The rule as to the quantity of oxygen (or air) to be added for the explosion was that employed in Dr. Bone's laboratory—add oxygen sufficient to make the explosive mixture or *knallgas* (i.e. $\text{CH}_4 + 2\text{O}_2$ and $2\text{H}_2 + \text{O}_2$), and excess oxygen (or air) as diluent of at least twice the volume of the *knallgas*. Thus if 100 mm. of gas are taken for the explosion, of which probably 30 mm. at most are burnable; if the latter is chiefly hydrogen, 15 mm. of oxygen are required for its complete combustion, so that the quantity of *knallgas* would be 45 mm., it is, therefore, necessary, to take at least $15 + (2 \times 45)$, that is 105 mm. of oxygen; or in other words the 100 mm. of gas should be made to at least 205 mm. with oxygen. This is the lowest limit, greater dilution is an advantage; with less dilution oxides of nitrogen and nitric acid are formed and some oxygen disappears, giving too great a contraction.

Oxygen was stored in a bottle over water, the gas was delivered through a suitable delivery tube into the laboratory vessel. Electrolytic gas was stored in test-tubes over mercury in a rack such as already described. Stop-cocks were kept lubricated with a solution of rubber in vaseline, prepared by gently heating together 20 parts of pure rubber, 10 of vaseline, and 1 of paraffin wax; the heat was maintained and the mixture stirred until the rubber was completely dissolved.

The following example illustrates the method of recording an analysis made with the Bone and Wheeler apparatus:—

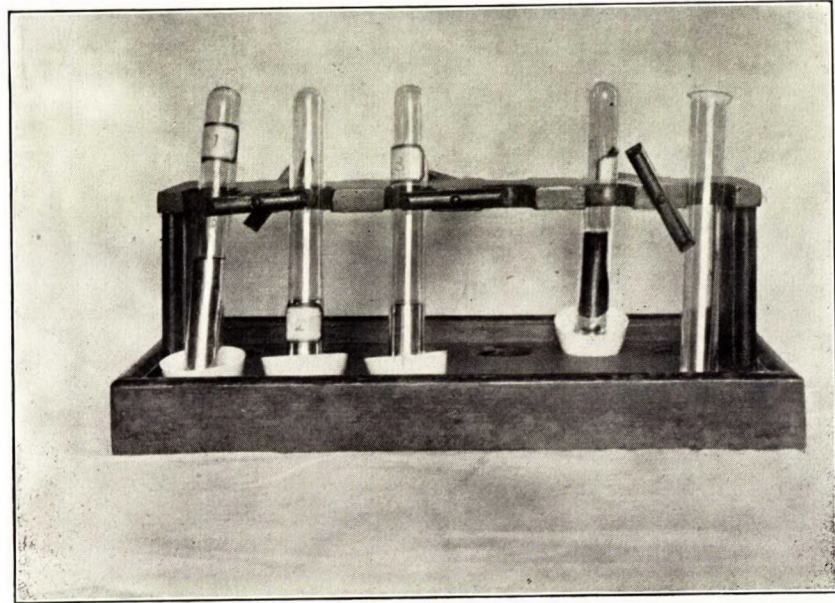

Rack for holding and storing gas samples.

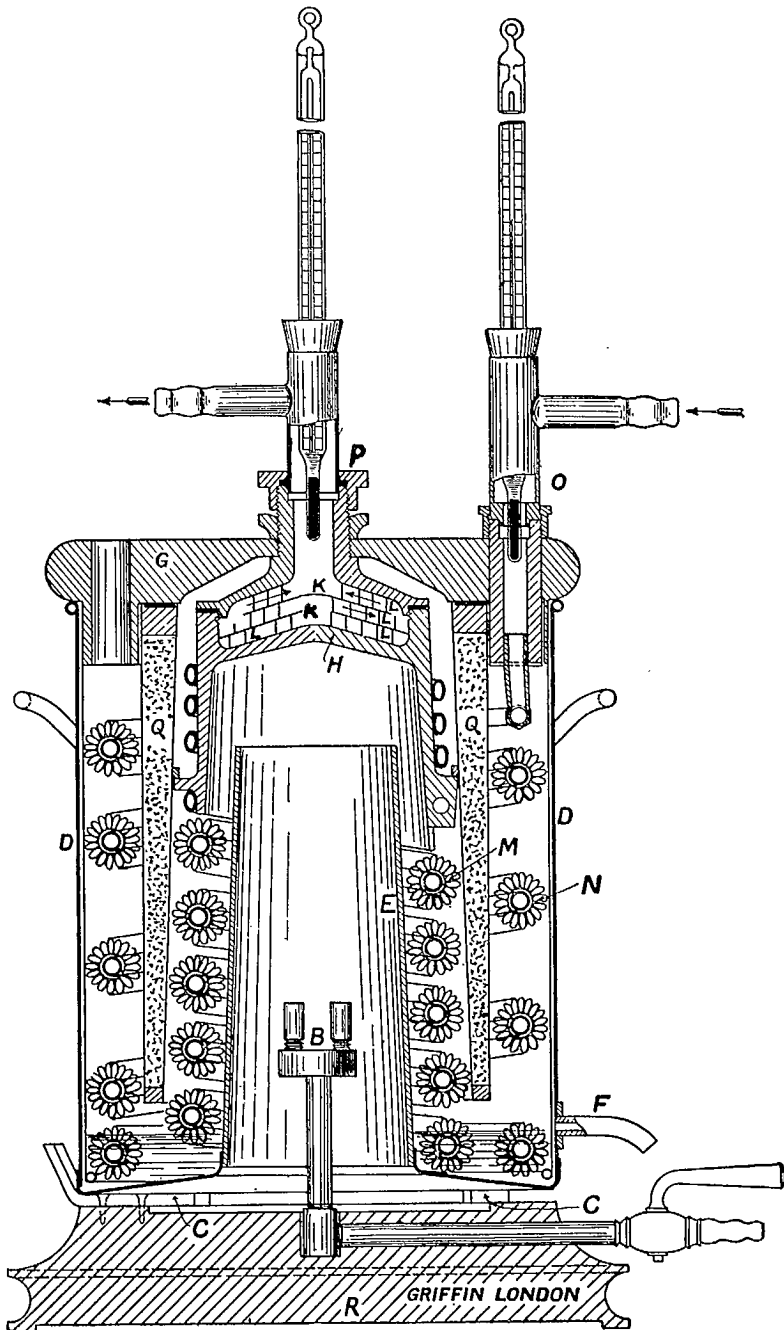

Fig. 55. Vertical section of Boys' gas calorimeter.

TABLE XLVII.

Analysis of Producer Gas With Bone and Wheeler Apparatus.

Vacuum reading.	0.0 mm.			
Initial reading.	120.5 "			
Gas taken	120.5 "			
After potash	109.4 "	decrease	11.1mm.	Carbon dioxide = 9.2%
After pyro.	108.7 "	"	0.7 "	Oxygen = 0.6
After bromine	108.5 "	"	0.2 "	Ethylene = 0.2
After cuprous chloride	92.0 "	"	16.5 "	Carbon monoxide = 13.7
After adding oxygen	364.7 "			
(After adding electrolytic gas)	424 "			
After explosion	334.6 "	"	30.1 "	
After potash	330.5 "	"	4.1 "	Methane = 3.4
Decrease due to hydrogen	$30.1 - (2 \times 4.1)$	=	21.9	
By difference	$21.9 \times \frac{2}{3}$	=	14.6"	Hydrogen = 12.1 Nitrogen = 60.8
				100.0

CALORIFIC VALUE OF GASEOUS FUELS

The calorimeter used for determining the calorific value of producer gas was one devised by Prof. C. V. Boys, and described by him in the Roy. Soc. Proc. 1906, 77A, p. 122; (also Jour. Soc. Chem. Indust., March 15, 1906, p. 234).

The usual method of gas calorimetry is employed; a jet of the gas is burnt in the calorimeter, and the heat of the combustion is absorbed by a current of water which flows through the instrument. The rate of flow of gas is determined by passing it through a gas meter, the rise in temperature of the water is determined by means of thermometers placed in the water at the points of entry and exit, and the rate of flow of the water is determined by collecting it in a measuring vessel: from these data the calorific value of the gas can be calculated.

The Boys gas calorimeter was designed to provide ample space for the circulation of the stream of burnt gases so that they pass slowly and freely through the instrument, and are thus effectively exposed to the cooling surfaces. The water content of the instrument has, on the other hand, been reduced to the smallest quantity; so that the outflowing water attains its ultimate temperature very quickly after the gas is lighted, and any variation in the temperature of the inflowing water is soon followed by a corresponding variation in the outflowing water. The whole of the circulating water takes continuously the same course, being debarred from any alternative route, and thus unequal heating and the attendant irregularity of the temperature at the outflow are avoided. The small content of water becomes adequate to abstract the whole of the heat from the slowly travelling stream of gases mainly by reason of its flow through a pipe of small diameter, the heat-collecting power of which is greatly increased by attached wires.

The following description of the apparatus is taken from the Notification of the Metropolitan Gas Referees (London, Eng.) for 1906.

The calorimeter is shown in vertical section in Fig. 55. It consists of three separate parts: (1) The base, **R**, carrying a pair of burners, **B**, (for producer gas these burners were replaced by a single, plain-tube burner) and a regulating tap. The upper surface of the base is covered with a bright

metal plate on which are three centering and lifting blocks, C. The blocks are so placed as to carry (2) the vessel, D, which is provided with a central chimney of copper E, and an outlet, F, for condensed water. Resting upon the rim of the vessel, D, are (3) the essential parts of the calorimeter attached to the lid, G. Beginning at the centre where the outflow is situated, there is a brass box which acts as a temperature equalizing chamber for the outlet water. Two dished plates of thin brass, K, K, are held in position by three scrolls of thin brass, L, L, L. The lower or pendant portion of the box is kept cool by water circulating through a tube which is sweated on to the outside of the bell. Connected to this tube at its lowest point by a union are six turns of copper pipe such as is used in a motor car radiator of the kind known as Clarksons. In this a helix of copper wire threaded with copper wire is wound round the tube and the whole is sweated together by immersion in a bath of melted solder. A second coil of pipe of similar construction, surrounding the first, is fastened to it at the lower end by a union. This terminates at the upper end in a block to which the inlet water box and thermometer holder are secured by a union as shown at O. An outlet water box, P, and thermometer holder are similarly secured above the equalizing chamber. The lowest turns of the two coils, M, N, are immersed in the water which in the first instance is put into the vessel D, but which is supplemented by water condensed from the burnt gases; the excess of water escapes from the overflow pipe F.

Between the outer and inner coils N, M, is placed a brattice, Q, made of thin sheet brass containing cork dust to act as a heat insulator. The brattice is carried by an internal flange which rests upon the lower edge of the casting, H. A cylindrical wall of thin sheet brass, a very little smaller than the vessel D, is secured to the lid, so that when the instrument is lifted out of the vessel the coils are protected from injury. The narrow air space between this and the vessel D, also serves to prevent interchange of heat between the calorimeter and the air of the room. The two thermometers for reading the water temperatures and a third for reading the temperature of the escaping gases are all near together and at the same level: the two former are divided on the Centigrade scale into tenths of a degree, and are provided with reading lenses and pointers which slide upon them; they were calibrated in the Physics Department of McGill University. The lid may be turned round into any position relatively to the gas inlet and condensed water drip that may be convenient for observation, and the inlet and outlet water boxes may themselves be turned so that their branch tubes point in any direction.

The accessories of the calorimeter consist of a gas pressure regulator; gas meter with opal dial 9" diameter, divided into 100 parts, capacity $\frac{1}{2}$ cubic foot per revolution; a measuring vessel of 2300 c.c. capacity, a change-over funnel to deliver water to the sink or measuring vessel as desired; and an overflow funnel to deliver water to the calorimeter at a constant head.

Fig. 56 shows the general view of calorimeter and accessories, and Plate XLIX (Part VIII) shows the calorimeter as set up on a special bench in the

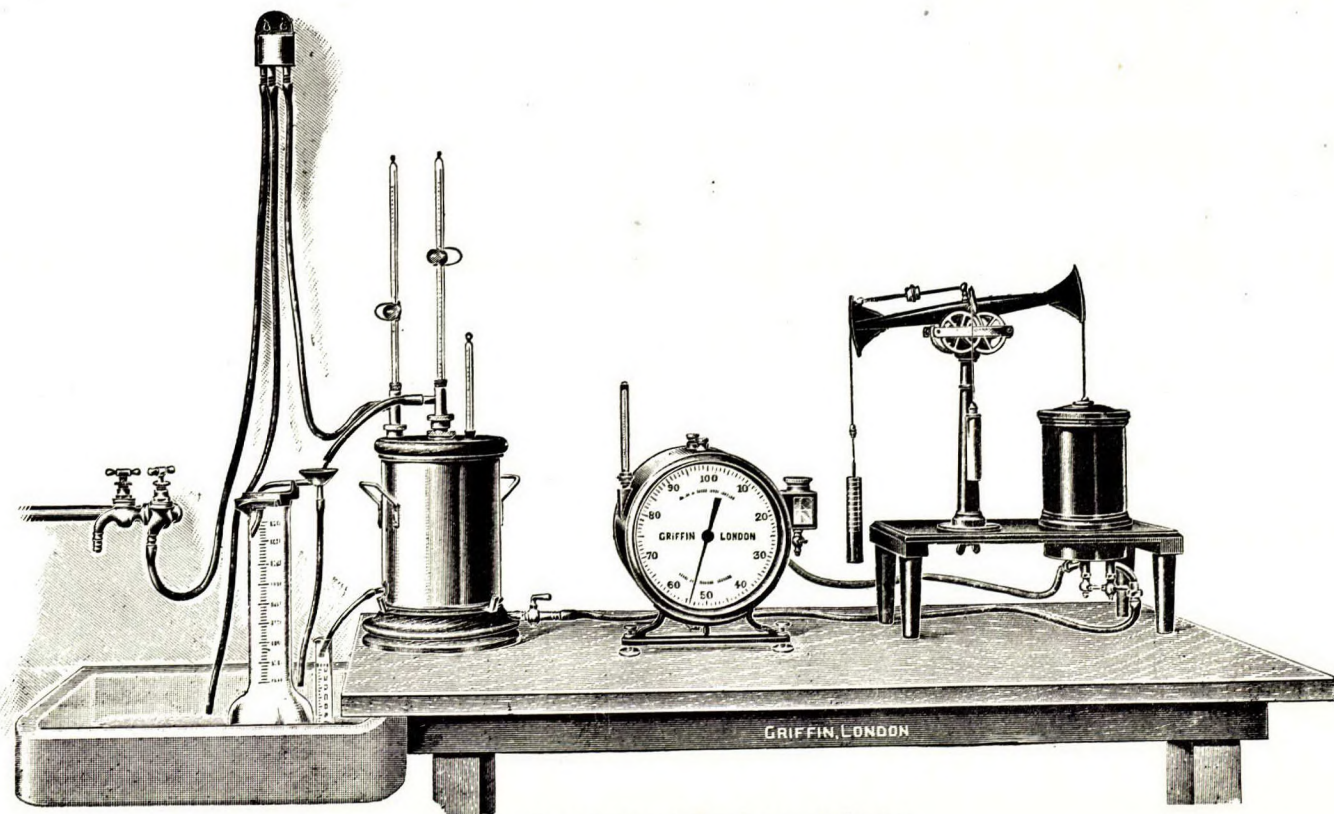

Fig. 56. General view of Boys' gas calorimeter.

gas producer house. Gas was supplied to the instrument from the gas main on the pressure side of the blower, it passed first through the pressure regulator, then the meter, and was finally burnt in the calorimeter—it should be noted that this order varies from that followed in testing city gas, in which case the gas passes through the meter first. The overflow funnel was fixed to the back of the bench at about 3 feet above the level of the instrument, the water flow thus regulated, was subsequently never changed; the gas was adjusted, when necessary, by the pressure regulator, so that when the burner was lit a rise of from 5° to 8°C. was produced in the temperature of the water during its passage through the calorimeter. The change-over funnel was placed on a rack over the measuring cylinder, and it was arranged that the outlet water from the calorimeter ran into the funnel and from thence, normally, into a waste pipe, but, that by moving the funnel it ran into the measuring vessel.

The burner of the calorimeter was lit at the beginning of a producer trial and kept burning throughout the trial, a determination was made as soon as the temperature became steady, and repeated at regular intervals during the trial; no determination was considered satisfactory in which there was any large variation in the inlet or outlet temperatures. The method was as follows: at a moment when the meter hand passed the zero mark the change-over funnel was moved to discharge into the empty measuring vessel, readings of the outlet temperature of the water were then taken once during each revolution of the meter until from 1600 to 1900 c.c. of water had been collected, the change-over funnel was then moved back when the meter hand again passed the zero. The inlet temperature was read at the beginning, middle, and end of the period; at the end the volume of water collected was noted, also the temperature of the gas in the meter, and the barometric pressure. As a rule $\frac{1}{2}$ or $\frac{3}{4}$ of a cubic foot of gas (6 or 9 revolutions of the meter) were burned during an experiment.

If V = the volume of gas burned in cubic feet, as measured by the meter,

W = volume of water collected, in litres.

T_1 = the mean temperature of the inlet water, in degrees Centigrade.

T_2 = " " " " " outlet " " " "

t = the temperature of the gas at the meter, in degrees Fahrenheit.

p = the vapour pressure of water at t° , F., in inches of mercury.

P = the barometric pressure, in inches of mercury.

then $V \times \frac{P-p}{30-0.5} \times \frac{459+t}{459+t}$ is the volume of the gas burned, corrected to cubic feet of gas measured moist at 60°F. and 30" of mercury pressure, (the vapour of water at 60°F. is 0.5" of mercury).

and $\frac{W \times (T_2 - T_1) \times 3.968}{V \times \frac{P-p}{30-0.5} \times \frac{459+t}{459+t}}$ or $\frac{W \times (T_2 - T_1) \times (459+t) \times 0.2255}{V \times (P-p)}$

gives the calorific value of the gas in British Thermal Units per cubic foot of gas measured moist at 60°F. and under a pressure of 30" of mercury.

(3.968 is the factor to convert kilograms calories into British Thermal Units).

The above is the gross calorific value: it was not thought worth while to collect the water from the burnt gas in order to determine the net calorific value.

The meter used was calibrated once a week by passing through it the air from a carboy of known capacity, and the volumes registered by the meter corrected when necessary. The necessity for this calibration was shown by the fact that a meter which had been in use some years gave readings nearly 11 per cent too low: the error being due to tar which had collected in the meter.

CALORIFIC VALUE CALCULATED FROM ANALYSIS OF GAS

By means of the following tables the gross and net calorific values of all producer gas samples analysed were calculated from the analysis, and expressed in B.T.U. per cubic foot of gas measured moist at 60°F. and under a pressure of 30" of mercury. The data used in compiling these tables were as follows:—

1 (kilogram) calorie = 1000 calories = heat required to raise 1 kilogram of water from 15° to 16° C. = 3.968 B.T.U.

0°C. = 273° absolute. 60°F. = 15.5°C. = 288.5° absolute.

1 gram-molecule of a dry gas occupies 22.38 litres at 0°C. and 760 mm. pressure.

Vapour pressure of water at 60°F. = 13 mm. of mercury.

30" = 762 mm.

1 cubic foot = 28.31 litres.

Therefore, the factor required to convert calories per gram-molecule into B.T.U. per cubic foot of moist gas at 60°F. and 30" pressure is:—

$$\frac{28.31 \times 3.968 \times 273 \times (762-13)}{22.38 \times 288.5 \times 760} = 4.683$$

<i>Gas.</i>	Calorific value in cals. per gram-molecule	× 4.683	B.T.U. per cubic ft. at 60°F. and 30"
Ethylene (C ₂ H ₄)	341.1	× 4.683	= 1597 gross.
	319.3	"	= 1495 net.
Carbon monoxide (CO)	68.2	"	= 319.4 gross and net.
Methane (CH ₄)	213.5	"	= 999.7 gross.
	191.7	"	= 897.6 net.
Hydrogen (H ₂)	69.0	"	= 323.0 gross.
	58.1	"	= 272.0 net.

The following example will make the use of the tables clear.

Analysis of Gas.		Calorific value from tables.	
		Gross.	Net.
CO ₂	= 9.8%		
C ₂ H ₄	= 0.5	8.0	7.5
O ₂	= 0.6
CO	= 8.9	28.4	28.4
CH ₄	= 3.6	36.0	32.3
H ₂	= 10.4	33.6	28.3
N ₂	= 66.2
Totals	100.0	106 B.T.U.	97 B.T.U.

TABLE XLVIII

Ethylene.

Gross or Higher Calorific Value in B.T.U. per cub. ft., moist, at 60°F. and 30".

Percentage of Ethylene	0.0	0.1	0.2	0.3	0.4	0.5	0.6	0.7	0.8	0.9
0	0.0	1.6	3.2	4.8	6.4	8.0	9.6	11.2	12.8	14.4
1	16.0	17.6	19.2	20.8	22.4	24.0	25.6	27.2	28.8	30.3
2	31.9	33.5	35.1	36.7	38.3	39.9	41.5	43.1	44.7	46.3
3	47.9	49.5	51.1	52.7	54.3	55.9	57.5	59.1	60.7	62.3
4	63.9	65.5	67.1	68.7	70.3	71.9	73.5	75.1	76.7	78.3

Net or Lower Calorific Value in B.T.U. per cub. ft., moist, at 60°F. and 30".

Percentage of Ethylene	0.0	0.1	0.2	0.3	0.4	0.5	0.6	0.7	0.8	0.9
0	0.0	1.5	3.0	4.5	6.0	7.5	9.0	10.5	12.0	13.5
1	15.0	16.4	17.9	19.4	20.9	22.4	23.9	25.4	26.9	28.4
2	29.9	31.4	32.9	34.4	35.9	37.4	38.9	40.4	41.9	43.4
3	44.9	46.4	47.8	49.3	50.8	52.3	53.8	55.3	56.8	58.3
4	59.8	61.3	62.8	64.3	65.8	67.3	68.8	70.3	71.8	73.3

TABLE XLIX

Carbon Monoxide.

Gross and Net Calorific Value in B.T.U. per cub. ft., moist, at 60°F. and 30".

Percentage of Carbon Monoxide	0.0	0.1	0.2	0.3	0.4	0.5	0.6	0.7	0.8	0.9
5	16.0	16.3	16.6	16.9	17.3	17.6	17.9	18.2	18.5	18.8
6	19.2	19.5	19.8	20.1	20.4	20.8	21.1	21.4	21.7	22.0
7	22.4	22.7	23.0	23.3	23.6	24.0	24.3	24.6	24.9	25.2
8	25.5	25.9	26.2	26.5	26.8	27.1	27.5	27.8	28.1	28.4
9	28.7	29.1	29.4	29.7	30.0	30.3	30.7	31.0	31.3	31.6
10	31.9	32.3	32.6	32.9	33.2	33.5	33.9	34.2	34.5	34.8
11	35.1	35.5	35.8	36.1	36.4	36.7	37.1	37.4	37.7	38.0
12	38.3	38.7	39.0	39.3	39.6	39.9	40.3	40.6	40.9	41.2
13	41.5	41.8	42.2	42.5	42.8	43.1	43.4	43.8	44.1	44.4
14	44.7	45.0	45.4	45.7	46.0	46.3	46.6	47.0	47.3	47.6

TABLE XLIX (Continued.)

Gross and Net Calorific Value in B.T.U. per cub. ft., moist, at 60°F. and 30°.

Percentage of Carbon Monoxide	0.0	0.1	0.2	0.3	0.4	0.5	0.6	0.7	0.8	0.9
15	47.9	48.2	48.6	48.9	49.2	49.5	49.8	50.2	50.5	50.8
16	51.1	51.4	51.7	52.1	52.4	52.7	53.0	53.3	53.7	54.0
17	54.3	54.6	54.9	55.3	55.6	55.9	56.2	56.5	56.9	57.2
18	57.5	57.8	58.1	58.5	58.8	59.1	59.4	59.7	60.1	60.4
19	60.7	61.0	61.3	61.6	62.0	62.3	62.6	62.9	63.3	63.6
20	63.9	64.2	64.5	64.8	65.2	65.5	65.8	66.1	66.4	66.8
21	67.1	67.4	67.7	68.0	68.4	68.7	69.0	69.3	69.6	69.9
22	70.3	70.6	70.9	71.3	71.6	71.9	72.2	72.5	72.8	73.1
23	73.5	73.8	74.1	74.4	74.7	75.1	75.4	75.7	76.0	76.3
24	76.7	77.0	77.3	77.6	77.9	78.3	78.6	78.9	79.2	79.5
25	79.9	80.2	80.5	80.8	81.1	81.5	81.8	82.1	82.4	82.7
26	83.0	83.4	83.7	84.0	84.3	84.6	85.0	85.3	85.6	85.9
27	86.2	86.6	86.9	87.2	87.5	87.8	88.2	88.5	88.8	89.1

TABLE L.

Methane.

Gross or Higher Calorific Value in B.T.U. per cub. ft., moist, at 60°F. and 30°

Percentage of Methane	0.0	0.1	0.2	0.3	0.4	0.5	0.6	0.7	0.8	0.9
0	0.0	1.0	2.0	3.0	4.0	5.0	6.0	7.0	8.0	9.0
1	10.0	11.0	12.0	13.0	14.0	15.0	16.0	17.0	18.0	19.0
2	20.0	21.0	22.0	23.0	24.0	25.0	26.0	27.0	28.0	29.0
3	30.0	31.0	32.0	33.0	34.0	35.0	36.0	37.0	38.0	39.0
4	40.0	41.0	42.0	43.0	44.0	45.0	46.0	47.0	48.0	49.0
5	50.0	51.0	52.0	53.0	54.0	55.0	56.0	57.0	58.0	59.0
6	60.0	61.0	62.0	63.0	64.0	65.0	66.0	67.0	68.0	69.0
7	70.0	71.0	72.0	73.0	74.0	75.0	76.0	77.0	78.0	79.0

TABLE L (Continued).

Net or Lower Calorific Value in B.T.U. per cub. ft., moist, at 60°F. and 30°.

Percentage of Methane	0.0	0.1	0.2	0.3	0.4	0.5	0.6	0.7	0.8	0.9
0	0.0	0.9	1.8	2.7	3.6	4.5	5.4	6.3	7.2	8.1
1	9.0	9.9	10.8	11.7	12.6	13.5	14.4	15.3	16.2	17.1
2	18.0	18.9	19.8	20.6	21.5	22.4	23.3	24.2	25.1	26.0
3	26.9	27.8	28.7	29.6	30.5	31.4	32.3	33.2	34.1	35.0
4	35.9	36.8	37.7	38.6	39.5	40.4	41.3	42.2	43.1	44.0
5	44.9	45.8	46.7	47.6	48.5	49.4	50.3	51.2	52.1	53.0
6	53.9	54.8	55.7	56.6	57.5	58.4	59.3	60.1	61.0	61.9
7	62.8	63.7	64.6	65.5	66.4	67.3	68.2	69.1	70.0	70.9

TABLE LI

Hydrogen.

Gross or Higher Calorific Value in B.T.U. per cub. ft., moist, at 60°F. and 30°.

Percentage of Hydrogen	0.0	0.1	0.2	0.3	0.4	0.5	0.6	0.7	0.8	0.9
0	0.0	0.3	0.6	1.0	1.3	1.6	1.9	2.3	2.6	2.9
1	3.2	3.6	3.9	4.2	4.5	4.9	5.2	5.5	5.8	6.1
2	6.5	6.8	7.1	7.4	7.7	8.1	8.4	8.7	9.0	9.4
3	9.7	10.0	10.3	10.7	11.0	11.3	11.6	11.9	12.3	12.6
4	12.9	13.2	13.6	13.9	14.2	14.5	14.9	15.2	15.5	15.8
5	16.2	16.5	16.8	17.1	17.4	17.8	18.1	18.4	18.7	19.1
6	19.4	19.7	20.0	20.4	20.7	21.0	21.3	21.6	22.0	22.3
7	22.6	22.9	23.3	23.6	23.9	24.2	24.6	24.9	25.2	25.5
8	25.8	26.2	26.5	26.8	27.1	27.5	27.8	28.1	28.4	28.8
9	29.1	29.4	29.7	30.0	30.4	30.7	31.0	31.3	31.7	32.0
10	32.3	32.6	33.0	33.3	33.6	33.9	34.2	34.6	34.9	35.2
11	35.5	35.9	36.2	36.5	36.8	37.2	37.5	37.8	38.1	38.4
12	38.8	39.1	39.4	39.7	40.1	40.4	40.7	41.0	41.3	41.7
13	42.0	42.3	42.6	43.0	43.3	43.6	43.9	44.3	44.6	44.9
14	45.2	45.5	45.9	46.2	46.5	46.8	47.2	47.5	47.8	48.1
15	48.5	48.8	49.1	49.4	49.7	50.1	50.4	50.7	51.0	51.4
16	51.7	52.0	52.3	52.7	53.0	53.3	53.6	53.9	54.3	54.6
17	54.9	55.2	55.6	55.9	56.2	56.5	56.9	57.2	57.5	57.8
18	58.1	58.5	58.8	59.1	59.4	59.8	60.1	60.4	60.7	61.1
19	61.4	61.7	62.0	62.3	62.7	63.0	63.3	63.6	64.0	64.3
20	64.6	64.9	65.3	65.6	65.9	66.2	66.5	66.9	67.2	67.5

TABLE LI (Continued).

Net or Lower Calorific Value in B.T.U. per cub. ft., moist, at 60°F. and 30%.

Percentage of Hydrogen	0.0	0.1	0.2	0.3	0.4	0.5	0.6	0.7	0.8	0.9
0	0.0	0.3	0.5	0.8	1.1	1.4	1.6	1.9	2.2	2.5
1	2.7	3.0	3.3	3.5	3.8	4.1	4.4	4.6	4.9	5.2
2	5.4	5.7	6.0	6.3	6.5	6.8	7.1	7.3	7.6	7.9
3	8.2	8.4	8.7	9.0	9.3	9.5	9.8	10.1	10.3	10.6
4	10.9	11.2	11.4	11.7	12.0	12.2	12.5	12.8	13.1	13.3
5	13.6	13.9	14.1	14.4	14.7	15.0	15.2	15.5	15.8	16.0
6	16.3	16.6	16.9	17.1	17.4	17.7	18.0	18.2	18.5	18.8
7	19.0	19.3	19.6	19.9	20.1	20.4	20.7	20.9	21.2	21.5
8	21.8	22.0	22.3	22.6	22.9	23.1	23.4	23.7	23.9	24.2
9	24.5	24.8	25.0	25.3	25.6	25.8	26.1	26.4	26.7	26.9
10	27.2	27.5	27.7	28.0	28.3	28.6	28.8	29.1	29.4	29.6
11	29.9	30.2	30.5	30.7	31.0	31.3	31.6	31.8	32.1	32.4
12	32.6	32.9	33.2	33.5	33.7	34.0	34.3	34.5	34.8	35.1
13	35.4	35.6	35.9	36.2	36.5	36.7	37.0	37.3	37.5	37.8
14	38.1	38.4	38.6	38.9	39.2	39.4	39.7	40.0	40.3	40.5
15	40.8	41.1	41.3	41.6	41.9	42.2	42.4	42.7	43.0	43.2
16	43.5	43.8	44.1	44.3	44.6	44.9	45.2	45.4	45.7	46.0
17	46.2	46.5	46.8	47.1	47.3	47.6	47.9	48.1	48.4	48.7
18	49.0	49.2	49.5	49.8	50.1	50.3	50.6	50.9	51.1	51.4
19	51.7	52.0	52.2	52.5	52.8	53.0	53.3	53.6	53.9	54.1
20	54.4	54.7	54.9	55.2	55.5	55.8	56.0	56.3	56.6	56.8

MISCELLANEOUS DETERMINATIONS

Specific Gravity of Coal—Typical pieces of coal of about 3 grams weight each, were taken, suspended by fine thread and weighed in air; they were then boiled in distilled water for from one-half to three-quarters of an hour, in order to remove the air from the pores, and then were cooled under reduced pressure, which removed any air still left in the coal, and the coal was finally weighed suspended in the water. The first weight of the coal divided by the difference between the first and the last weights gives the specific gravity of the piece of coal taken. This determination was not included in the regular tests made, as the heavy solution tests, described in Vol. I, Part V, gave similar but fuller and more valuable information.

Soluble Matter in Coal.—A sample of coal was treated with water with a view, chiefly, to determine whether any of the nitrogen compounds of the coal were soluble in water. The coal chosen for the experiment, No. 2010, contained 1.7 per cent nitrogen, 5.2 per cent sulphur, and 16.9 per cent ash. A tall cylinder was taken, and the shorter limb of a siphon tube introduced into it and connected at the end to an inverted funnel resting on the bottom of the cylinder. One kilogram of the coal, crushed to $\frac{1}{4}$ " size, was put into the cylinder which was then filled with distilled water; the water was siphoned off at the rate of about half a litre a day: coal was prevented from entering the siphon tube by the inverted funnel, fresh water was added from time to time to replace that removed. The dissolved matter was found to consist almost entirely of iron salts, presumably formed by the slow oxidation of the iron pyrites in the coal, as these salts came over in larger quantities when the siphon was re-started after the cylinder had been allowed to run dry, and the moist coal thus brought into contact with the air. As after even four or five days extraction there did not appear to be any reduction in the material going into solution, the extraction was stopped, the solution was evaporated to dryness, and 13.1 grams of solid matter were thus obtained. This was found to contain only 0.18 per cent of nitrogen in the form of ammonium salts—corresponding to 0.0023 per cent in the coal—no albuminoid nitrogen, and no nitrates.

Soluble Matter in Water.—A litre of the Montreal water, as used in the washing trials, etc., was filtered and then evaporated to dryness in a platinum basin over a water bath; the residue left, dried at 105°C., weighed 0.0984 grams; after it had been ignited in a muffle it weighed 0.0701 grams. These two weights correspond to 9.84 and 7.01 parts per hundred thousand respectively.

Hydrogen Sulphide and Sulphur Dioxide in Producer Gas.—These were first determined by the method described by J. C. Thomlinson in the "Chemical News" for Feb. 21, 1908. The gas was aspirated very slowly through a small bottle containing .25 c.c. of a water solution of iodine and of sodium carbonate, $\frac{1}{10}$ normal both as regards the iodine and the sodium carbonate (prepared by adding 50 c.c. of a decinormal solution of iodine in

potassium iodide solution, to an equal volume of decinormal sodium carbonate solution, and diluting the mixture to 250 c.c.). The gas was stopped as soon as the iodine was decolorized; the volume of gas drawn through was determined by measuring the water run out of the aspirator bottle; and any sulphuric acid formed in the small bottle was determined by titrating with standard alkali; from these data the percentages of hydrogen sulphide and sulphur dioxide present in the gas were calculated. The reactions involved are shown by the following equations:—

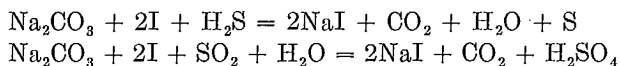

As no sulphur dioxide was found in the first few samples, which were tested by this method, a simpler method was substituted later to determine the hydrogen sulphide only; in this method two litres of the gas were aspirated through a solution of caustic soda, the solution was just acidified with hydrochloric acid, and the hydrogen sulphide present at once titrated with fiftieth normal iodine solution, with the addition of a little starch solution as indicator.

This determination was only made for a few producer trials. Two trials were selected in which the coal being tested contained a high percentage of sulphur, and a third with coal containing a medium percentage. The results obtained are as follows: gas from coal No. 10 (5.4 per cent sulphur) contained, as the mean of three determinations, 0.22 per cent of hydrogen sulphide; gas from coal No. 11 (5.8 per cent sulphur) contained, mean of ten determinations, 0.40 per cent of hydrogen sulphide; and gas from coal No. 36 (2.4 per cent sulphur) contained, mean of five determinations, 0.22 per cent by volume of hydrogen sulphide gas.

EXPERIMENTS ON THE FUSIBILITY OF ASHES.

Some experiments were made to find out whether it was possible to foretell the trouble a coal would give in a boiler or producer, on account of formation of clinker, by a determination in the laboratory of the fusibility of its ash.

The determination of the fusibility of the ash was found to involve considerable difficulties, largely occasioned by the fact that ash has no definite melting point, but appears to get gradually softer as the temperature rises. In the method first employed, cones of ash were made, and these were heated in a crucible inside a furnace, and the temperature noted at which the cone toppled over or gave other visible signs of fusion; the temperature was recorded by means of a pyrometer consisting of a platinum, platinum-iridium thermocouple, the hot junction being placed almost in contact with the cone.

The ash was prepared by burning the finely powdered coal in a muffle furnace and was, therefore, itself pulverulent. All attempts to make the cones in a conical mould failed, so they had to be made by hand, a little molasses diluted with water being used as a binding material. The cones were first dried in an oven, and then given a preliminary gentle roasting in a furnace before being used. Each cone was placed on some neutral re-

fractory material (such as chrome iron ore) in the bottom of the crucible, and the crucible was heated in a gas fired furnace in which the flames circled around it. When the crucible became white hot, it proved very difficult to observe the cone, even with blue glasses, unless it was either hotter or colder than the crucible, when it was silhouetted as a light or a dark object against the latter and could be easily watched, but, in such cases, the pyrometer readings could not then be relied upon to give the true temperature of the cone. The lack of uniformity of the handmade cones caused irregularity in the observed temperatures of fusion; a thicker or denser cone required a higher temperature than a thinner or lighter one before bending over, or collapsing. It was also shown that whereas one ash might soften at a low temperature and hardly show any further change with a considerable rise in temperature, another ash might not begin to soften until a high temperature and then might go quite liquid with only a slight further rise. It was, therefore, not only difficult to get consistent results by this method, but also the information obtained by it was too incomplete to be of much value.

In the second method several cylinders of ash were made in a briquetting press from each sample, and these were separately heated up to a definite temperature, one being heated to 1200°C., another to 1300°C., a third to 1400°C., and a fourth to 1500°C.; the temperatures were determined by means of a Morse optical pyrometer, and the effect on the ash cylinders was noted after they had been withdrawn from the oven. A simple form of press was used to make the cylinders, which were $\frac{3}{8}$ " in diameter, about 1" long, and with a slightly pointed top. A powerful mechanic's vice was used to apply pressure; the ash was just moistened with molasses and water to cause it to bind. The cylinders were mounted on small infusible base plates made of chrome iron ore, moulded damp after the addition of about 10 per cent of fireclay; three or four cylinders from different samples were mounted on each plate. These cylinders were heated on their plate on the bottom of a gas-heated furnace (designed by Dr. A. Stansfield), in which the air blast is preheated, and in which a very high and uniform temperature can be obtained; they were covered by an inverted graphite crucible with an opening cut in the side, through which the temperature could be observed with the optical pyrometer. In this method it was not necessary to watch the behaviour of the cylinders in the furnace, and the temperature of either a cylinder or the crucible could be determined by the optical pyrometer, in case they differed.

This method was not developed until after all the boiler and producer trials had been completed, and it was not thought worth while to carry out many tests; but seven sets of cylinders were heated after the method had been fully developed. The results are shown in Plates LXI and LXII. A was heated to 1200° C., B and E to 1300° C., C and F to 1400° C., J to 1500° C., and D to 1530° C. The tests showed that in the three cases tried, the ash from a washed coal was less fusible than the ash from the corresponding unwashed coal. The results are interesting, but it is difficult to see much connexion between them and the following data taken from the report of the boiler trials made on these coals; but the apparent discrepancies are possibly caused by variations in the temperature of the boiler fire.

- Coal 7 —Clinker thin, vitreous, and adherent.
- “ 23 M—Clinker very soft and easily removed; coal very suitable for shaking grate.
- “ 223 M—(Coal 23M after washing)—Like 23 M.
- “ 25 —Clinker hard; shaking grate could be used with steam.
- “ 225 —(Coal 25 after washing). Hard layer of clinker sticking to bars until steam was put on; shaking grate might be used with steam.
- “ 36 —Bluish plastic clinker easily removed.
- “ 236 —(Coal 36 after washing). Clinker troublesome until steam used.
- “ 43 —Clinker viscous, conditions improved with steam; shaking grate could be used with steam.

DISCUSSION OF METHODS OF WORK

The prevention of moisture change in coal during sampling, grinding, and storage; the determination of water; and the effect of water on other analyses are difficult problems of coal analysis. These problems were very carefully considered before the methods employed were adopted, and most of the departures from more usual methods were made to lessen danger of errors through moisture.

During the last four years, that is to say since the present investigation was begun, a number of papers have been published on the weathering of coal and allied problems, which show that coal samples undergo considerable oxidation when dried at 105° C., and also during storage at ordinary temperatures; these facts were known before, but the recent work has strongly emphasized the importance of bearing them in mind in all considerations of methods of analysis. It is now apparent that the laboratory work of this investigation would have been less open to criticism in this respect, if the analyses had been made on air dried samples, or if the coal had been dried in an atmosphere of nitrogen or other inert gas instead of in heated air. Coal analyses are, however, most conveniently useful when reported on the dry coal, and there is a distinct advantage in making the analyses in the way they are to be reported rather than in analysing moist samples and correcting for the moisture contained. The error caused by oxidation of the coal during drying is, fortunately, rarely if ever serious, except possibly with lignites, but unfortunately the pressure of imperative work prevented any attempt being made to determine the exact extent of the change they undergo in this way. The oxidation of the ground sample after drying might have been prevented by making a complete analysis of each sample as soon as it was prepared; but, as has already been stated, this would have been quite impossible without a far larger staff and equipment.

In order that the analyses made should represent the coal as mined, it would have been necessary to sample the coal underground, ship in a hermetically sealed container to the laboratory, and make the complete analysis as

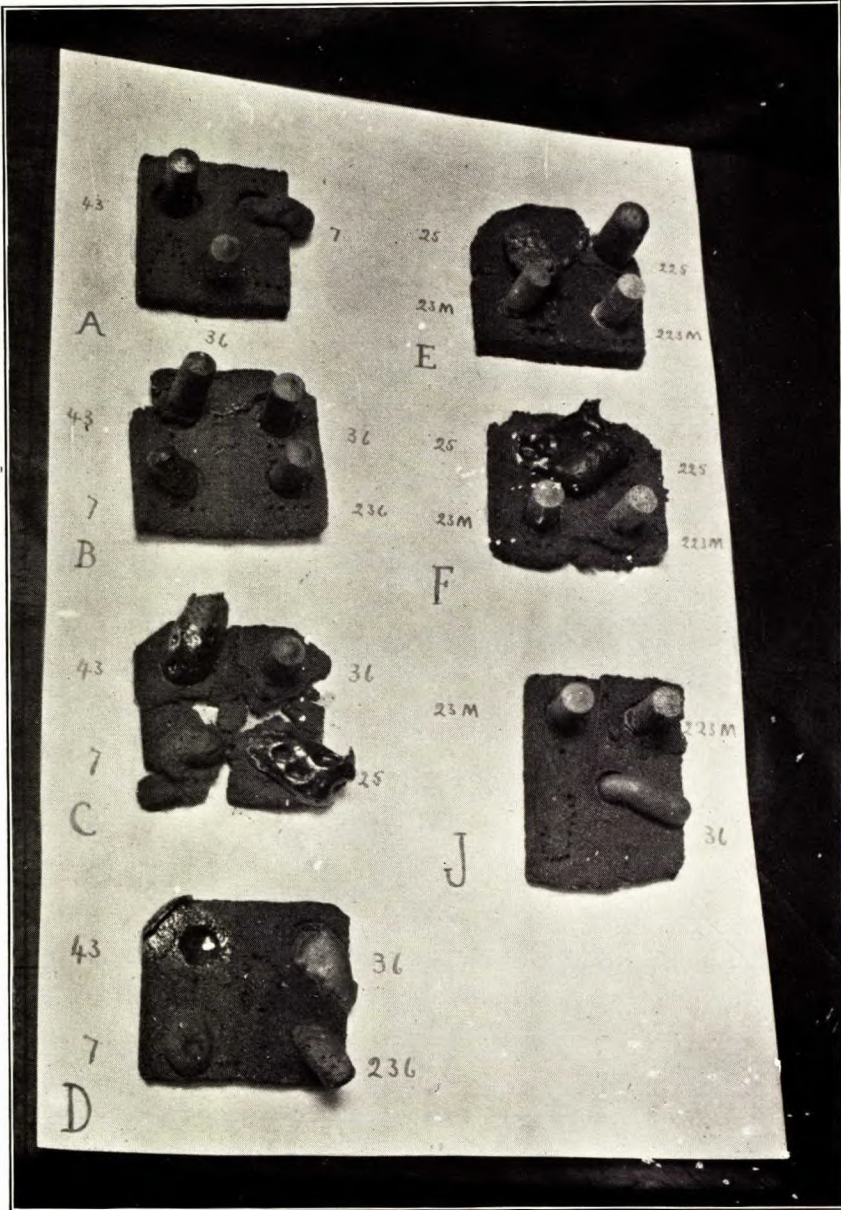

Ash cylinders after heating, viewed at an inclination.

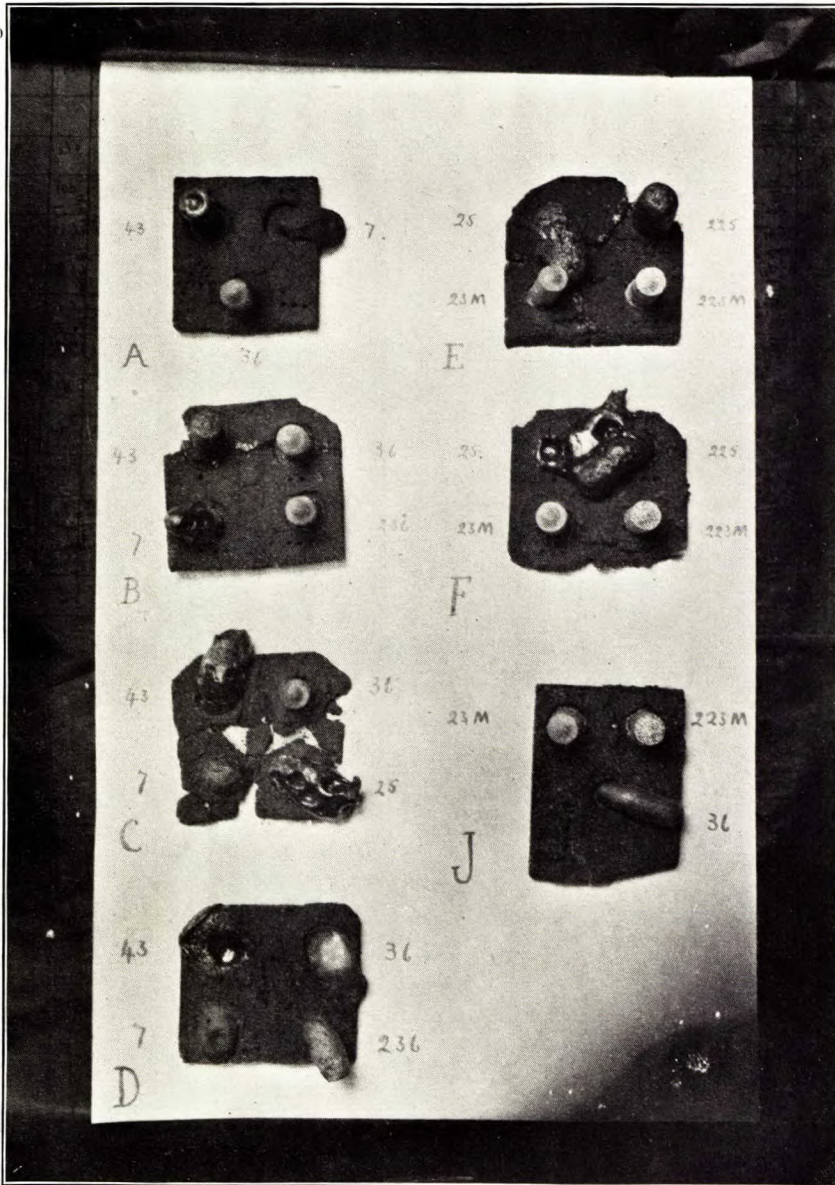

Ash cylinders after heating, viewed from above.

soon as this container was received; such analyses would, however, have been of doubtful value, as they would not represent the product of the mine as it reaches the consumer.

The whole subject of coal analysis is so beset with difficulties that it is almost impossible to avoid one difficulty without encountering another.

A committee of the International Congress of Applied Chemistry is at present considering the question of moisture in fuels (and ores), and it is to be hoped that they will be able to suggest, in their report to the meeting in New York in 1912, some method of analysis which will meet with general international adoption. In view of this it is now only necessary to discuss the advantages and disadvantages of some of the methods actually employed—not to suggest or recommend methods for Canadian adoption; other methods have been sufficiently discussed in describing them.

The method employed for obtaining a sample from the main consignment of coal was very thorough, and guarded against the greatest difficulty in sampling which lies in ensuring that a correct proportion of fines and of lump go into each portion every time the sample is subdivided by shovel or by riffle. In cases where a coal seam contains two portions, one of which is much stronger than the other, the fines and the lumps of coal sometimes differ considerably in composition and a true sample is hard to obtain. One coal in the series showed this characteristic to an exceptional degree, the different subsidiary samples checking badly (as to ash content) amongst themselves and with the main sample; several fresh samples of this coal were prepared and the one finally chosen for analysis was that in which the ash content came nearest to being the mean of that of the other samples.

It was necessary to decide, at the beginning of the investigation, between the relative merits of snap samples and average samples for flue gas and producer gas; that is between samples taken at a particular time and samples taken to represent the average gas produced during a given interval of time, such as one hour. It was decided that the snap sample was the better. In boiler trials, the flue gas analysis serves to indicate, both to those in charge of the trial during its operation and also to those who study the records afterwards, the way in which the stoking was carried out; for both these purposes the snap sample, taken when the boiler was in normal operation and not whilst firing or slicing was going on, gives the fullest information. The average sample is only better as giving information as to the total heat wasted up the chimney; of these uses, that of assisting in the correct stoking during the course of the trial was regarded as the most important, and the snap sample was, therefore, adopted; similar reasons led to the adoption of snap samples for producer trials also.

The system of air drying employed appeared on the whole to be very satisfactory: the length of time taken to dry a sample was a disadvantage in that the coal was doubtless slowly oxidizing during this time, but, as the air dried samples were not afterwards employed for the regular analyses of the coal, this did not seriously matter. In this and all other moisture determinations a slightly more accurate result could possibly have been obtained by

weighing the water driven off from the coal, rather than by noting the loss in weight of the sample, which latter is affected by any loss due to escaping gases, and by any gain due to absorption of oxygen; but this method, while practicable, would have involved an unjustifiable amount of work.

The ball mill was chosen to grind coal samples because it enables comparatively large samples to be finely ground and thoroughly mixed without any appreciable change in moisture. A screen analysis of a coal ground for three hours in the mill showed that only 0.05 per cent stayed on a 100 mesh screen and 1.25 per cent on a 200 mesh screen: this very fine grinding is an advantage in that any impurities will be very thoroughly disseminated throughout the whole sample, moisture can be quickly and completely removed, and determinations such as that of sulphur can be more satisfactorily made on fine samples than on coarse; it is a disadvantage in that more surface of the coal is exposed and, therefore, oxidation can proceed more rapidly and farther.

The advantages of the use of small sample tubes for the final sample have been mentioned: that their contents were liable to deterioration, in spite of their being closed with waxed corks and stored in stoppered bottles, was shown in the following way. Briquettes sufficient for two determinations of calorific value were usually made soon after the sample had been prepared; if for any reason these were not sufficient and fresh briquettes were made at a later date for extra determinations, the fresh briquettes usually gave a lower calorific value than the old ones, showing that the coal stored as an impalpable powder in a tube, deteriorated more rapidly (by oxidation from the air contained in the tube) than the same coal stored in the form of strongly compressed briquettes. The difference found varied with the coal, being highest with the lignites, but after two or three months storage it usually amounted to about 50 calories per gram. The oxidation of the coal samples is also shown by comparison of the analyses given of the regular samples and those obtained later for coking tests; the latter samples were analysed shortly after being received, and in nearly every case the percentage of oxygen found in them was less than in the corresponding regular samples, the completion of the analysis of which was more delayed.

It is well known that, in the determination of volatile matter in coal, the size of the crucible employed, temperature of the flame used, etc., will affect the result obtained. The results obtained in this investigation by the methods already described are probably not only consistent amongst themselves, but also in close agreement with the results that would be obtained by other chemists in general practice. As it is generally considered necessary to determine volatile matter on air dry rather than on dry coal, the determination was made on nearly all regular samples in both ways. Of the 73 samples tested in both ways (lignites excluded), 37 gave the higher result with dry coal and the average difference was 0.74 per cent, whilst 36 gave the higher result with air dried coal with an average difference of 0.51 per cent.

In the determination of ash it was found that different methods gave slightly different results: ash was seldom determined in any sample by all

three methods employed, but the following comparisons have been calculated from the determinations made in two or more ways:—

TABLE LII.
Comparative Ash Determinations.

	Coal burned in muffle.	Coal burned over burner.	Coal burned in oxygen in comb- ustion furnace.
Mean of 11 determinations.....	14.45%	14.56%	14.59%
Mean of 80 "	10.72	11.09
Mean of 3 "	5.54	5.66

It has already been shown that the ash left after the oxidation of coal is not the same as the original mineral impurity in the coal; the original impurities in the coal are changed in different ways according to the rapidity of oxidation and the temperature to which they are subjected. Thus, for example, sulphur present in pyrites in the coal may be partially oxidized to sulphur dioxide and escape as such, or may be more completely oxidized to sulphuric anhydride and remain in the ash as a sulphate of calcium or other metal. Carbonates may be more or less completely decomposed, with the evolution of carbon dioxide, according to the temperature employed. The muffle furnace gives a higher temperature and less energetic oxidation than is usually the case in a combustion furnace—two conditions which lead to a lower result for the ash. W. Pollard has shown¹ that in a case where the percentage of ash found in a combustion tube was higher than in a muffle, the percentage of sulphur in the ash was correspondingly higher. It is worth noting that, in the seventy boiler trials carried out, the ash and clinker left behind at the end of a trial, after deducting the combustible matter present, weighed on the average over 25 per cent less than the weight of ash put into the boiler as calculated from the analysis of the coal; doubtless much of this loss is due to ash carried over into the flues and up the smoke stack, but it seems probable that some of the discrepancy is due to the difference in conditions between the boiler furnace and the muffle furnace.

Some of the errors in coal analyses are due rather to certain constituents of the coal, than to the particular methods employed for analysis; the following are referred to by Dr. Pollard in the article already mentioned.

When coal contains carbonates—usually of calcium and magnesium—not only does it affect the ash as stated before, but, in the determination of volatile matter carbon dioxide is evolved, and is thus reckoned as volatile matter rather than as ash, as it should be if ash is considered to be the original mineral matter in the coal; the escaping carbon dioxide may also be partially reduced at the expense of the carbon present— $\text{CO}_2 + \text{C} = 2\text{CO}$ —the percentage of fixed carbon found being thus too low. In the ultimate analysis the percentage of ash found will be too low, and the carbon and oxygen too high. If, however, ash is considered to be the residue left

¹See Chapter on "Accuracy of Coal Analysis" by W. Pollard, in "The Coals of South Wales," a memoir of the Geological Survey of England and Wales, 1908.

after complete oxidation, no error is caused, except that in different determinations the carbonate will be decomposed to a greater or less extent, according to the temperature employed, so that duplicates will not agree.

Ferrous minerals in the coal become oxidized to the ferric condition when burnt, so that so far as they are concerned the ash found by analysis is greater than in the original coal, and the oxygen, which is found by difference, is, therefore, lower.

Pyrites in the coal are also oxidized when the coal is burned, the iron being left as ferric oxide; for every 240 parts by weight of iron pyrites in the original coal, 160 parts of ferric oxide will be weighed in the ash, and 128 parts of sulphur in the sulphur determination; the result again is that the determined oxygen is less than in the original coal.

Coal may also contain as impurity, minerals containing water of constitution not driven off by drying at 105°C. The hydrogen and oxygen of such water will appear in the results of the analysis as hydrogen and oxygen of the coal instead of in the ash.

Dr. Pollard summarizes the approximate errors considered by him, in the following table. "No great accuracy is claimed for these figures, they are only intended to show in what direction, and approximately to what extent, the composition of a coal may be affected." The figures given refer to the percentages of the constituents calculated to an ash and sulphur free coal.

TABLE LIII
Summary of Approximate Errors in Coal Analyses.

	C %	H %	O %	N %	C/H Ratio.
Carbonates.....	-1.14	-0.07	+1.22	-0.01	+0.1
Ditto in extreme case.....	-4.4	-0.2	+4.7	-0.1	+0.8
Ferrous minerals in ash.....	+0.2	-0.2	+0.1
Pyrites.....	+0.85	+0.05	-0.90	+0.01
Hydrous minerals.....	+0.1	-0.4?
Maximum observed alteration in four Welsh coals after four years storage ¹ ..	-1.39	0.21	+1.43	+0.17	+0.51

In conclusion it should be explained that the methods which were employed have been fully described and possible errors indicated in order that the following analyses can be judged upon their merits. It should be clearly understood that the majority of possible errors, whilst affecting the absolute analysis of any coal to a limited extent, will have little or no effect upon the relative merits of the coals judged from the analyses. The coals were all analysed in the same way, except for trifling differences already mentioned, so that the analyses are consistent amongst themselves.

It also seems desirable to call attention to the fact that the inherent difficulties and errors of any known method of coal analysis are

¹ Two of these coals were bituminous, one was a steam coal, and the last was an anthracite. The maximum alteration occurred with the bituminous coals, the alteration with the steam coal was very slight and with the anthracite it was practically *nil*.

such, that, although in the work of this investigation very great care was taken both in the choice of methods and in the carrying out of the work, yet it would be unscientific and would give a false idea of accuracy, to report analyses to one hundredths of one per cent, or calorific values to the single calorie. The very general and misleading custom among coal chemists of expressing results to the hundredth of one per cent, even in proximate analyses where the very units are doubtful, is only excusable, because it is the custom, and because those chemists, whose work is sufficiently careful to enable them to realize the unavoidable inaccuracies, do not care to appear to be making less careful analyses than others.

LIST OF COALS TESTED

SYDNEY COAL FIELD, CAPE BRETON CO., N.S.

- 50* Gowrie seam, North Atlantic Collieries Ltd., Port Morien, N.S.
 36 Dominion No. 7. Hub seam, Dominion Coal Co., Ltd., Glace Bay, N.S.
 35 Dominion No. 9. Harbour seam, Dominion Coal Co., Ltd., Glace Bay, N.S.
 35 SP Dominion No. 5. Phalen seam, Dominion Coal Co., Ltd., Glace Bay, N.S.
 38 Dominion No. 1. Phalen seam, Dominion Coal Co., Ltd., Glace Bay, N.S.
 37 Dominion No. 10. Emery seam, Dominion Coal Co., Ltd., Glace Bay, N.S.
 39 Dominion No. 12. Lingan seam, Dominion Coal Co., Ltd., Glace Bay, N.S.
 13 No. 1 Colliery, Nova Scotia Steel and Coal Co., Ltd., Sydney Mines, N.S.
 12 No. 3 Colliery, Nova Scotia Steel and Coal Co., Ltd., Sydney Mines, N.S.

INVERNESS COAL FIELD, INVERNESS CO., N.S.

- 14 Inverness Colliery, Inverness Railway and Coal Co., Inverness, N.S.
 15 Port Hood Colliery, Richmond Railway Coal Co., Ltd., Port Hood, N.S.

PICTOU COAL FIELD, PICTOU COUNTY, N.S.

- 4 Six Foot seam, Vale Colliery, Acadia Coal Co., Ltd., New Glasgow, N.S.
 16 Foord seam, Allan Shaft Colliery, Acadia Coal Co., Ltd., Stellarton, N.S.

*The distinguishing numbers of the coal samples were arbitrarily assigned at the time, and have been retained for convenient reference. They have no other significance. J. B. P.

- 1 Third seam, Albion Colliery, Acadia Coal Co., Ltd., Stellarton, N.S.
- 2 Cage Pit seam, Albion Colliery, Acadia Coal Co., Ltd., Stellarton, N.S.
- 8 Main seam, Acadia Colliery, Acadia Coal Co., Ltd., Westville, N.S.
- 3 Main seam, Drummond Colliery, Intercolonial Coal Mining Co., Ltd., Westville, N.S.

SPRINGHILL COAL FIELD, CUMBERLAND CO., N.S.

- 49 No. 1 Colliery, Cumberland Railway and Coal Co., Ltd., Springhill, N.S.
- 5 No. 2 Colliery, Cumberland Railway and Coal Co., Ltd., Springhill, N.S.
- 6 No. 3 Colliery, Cumberland Railway and Coal Co., Ltd., Springhill, N.S.

JOGGINS-CHIGNECTO COAL FIELD, CUMBERLAND CO., N.S.

- 7 Chignecto Colliery, Maritime Coal, Railway, and Power Co., Ltd., Chignecto, N.S.
- 9 Minudie Colliery, Minudie Coal Co., Ltd., River Hebert, N.S.
- 10 Joggins Colliery, Canada Coals and Railway Co., Ltd., Joggins, N.S.

GRAND LAKE COAL FIELD, QUEENS CO., N.B.

- 11 King's mine, G. H. King, Minto, N.B.

SOURIS COAL FIELD, SASK.

- 40 Western Dominion Collieries, Ltd., Taylorton, Sask.
- 41 Eureka Coal and Brick Co., Ltd., Estevan, Sask.

EDMONTON COAL FIELD, ALTA.

- 46 Strathcona Coal Co., Ltd., Strathcona, Alta.
- 42. Parkdale Coal Co., Ltd., Edmonton, Alta.
- 45 Standard Coal Co., Edmonton, Alta.

BELLY RIVER COAL FIELD, ALTA.

- 43 Canada-West Coal Co., Ltd., Taber, Alta.
- 44 Galt Colliery, Alberta Railway and Irrigation Co., Ltd., Lethbridge, Alta.
- 47 Breckenridge and Lund Coal Co., Ltd., Lundbreck, Alta.

FRANK-BLAIRMORE COAL FIELD, ALTA.

- 48 Seven Foot seam (No. 1 Byron), Leitch Collieries, Ltd., Passburg, Alta.
- 32 Hillcrest Colliery, Hillcrest Coal and Coke Co., Ltd., Hillcrest, Alta.
- 33 Bellevue Colliery, No. 1 seam, West Canadian Collieries Co., Ltd., Bellevue, Alta.
- 28 Lille Colliery, No. 1 seam, West Canadian Collieries Co., Ltd., Lille, Alta.
- 34 Denison Colliery, No. 2 seam, International Coal and Coke Co., Ltd., Coleman, Alta.
- 34 SP Denison Colliery, No. 4 seam, International Coal and Coke Co., Ltd., Coleman, Alta.

CROWSNEST COAL FIELD, B.C.

- 31 No. 3 mine, Michel Colliery, Crowsnest Pass Coal Co., Ltd., Michel, B.C.
- 30 No. 7 mine, Michel Colliery, Crowsnest Pass Coal Co., Ltd., Michel, B.C.
- 29 No. 8 mine, Michel Colliery, Crowsnest Pass Coal Co., Ltd., Michel, B.C.
- 51 No. 2 seam south, Hosmer Mines, Ltd., Hosmer, B.C.
- 52 No. 6 seam south, Hosmer Mines, Ltd., Hosmer, B.C.
- 53 No. 8 seam south, Hosmer Mines, Ltd., Hosmer, B.C.
- 27 No. 2 mine, Coal Creek, Crowsnest Pass Coal Co., Ltd., Fernie, B.C.
- 26 No. 5 mine, Coal Creek, Crowsnest Pass Coal Co., Ltd., Fernie, B.C.

CASCADE COAL FIELD, ALTA.

- 25 No. 1 or Old mine, H. W. McNeil Co., Ltd., Canmore, Alta.
- 23 Pea size, Bankhead Colliery, Bankhead Mines, Ltd., Bankhead, Alta.
- 23 SP Buckwheat size, Bankhead Colliery, Bankhead Mines, Ltd., Bankhead, Alta.
- 23 M Mixed, 23 and 23SP, Bankhead Colliery, Bankhead Mines, Ltd., Bankhead, Alta.
- 24 Briquettes from Bankhead Colliery, Bankhead Mines, Ltd., Bankhead, Alta.

SIMILKAMEEN COAL FIELD, B.C.

- Ex. 1 No. 1 opening, Granite Creek, B.C.
- Ex. 2 No. 2 opening, Granite Creek, B.C.
- Ex. 3 No. 4 opening, Granite Creek, B.C.

NICOLA VALLEY COAL FIELD, B.C.

- 22 Jewel seam, No. 1 mine, Middlesboro Colliery, Nicola Valley Coal and Coke Co., Ltd., Coutlee, B.C.
- 22 SP Rat Hole seam, No. 2 mine, Middlesboro Colliery, Nicola Valley Coal and Coke Co., Ltd., Coutlee, B.C.
- 22 M Mixture of 22 and 22SP, Middlesboro Colliery, Nicola Valley Coal and Coke Co., Ltd., Coutlee, B.C.

NANAIMO-COMOX COAL FIELD, VANCOUVER ISLAND, B.C.

- 20 Wellington seam, Wellington-Extension Colliery, Wellington Colliery Co., Ltd., Extension, B.C.
- 18 Upper seam, No. 1 mine, Western Fuel Co., Ltd., Nanaimo, B.C.
- 17 Lower seam, No. 1 mine, Western Fuel Co., Ltd., Nanaimo, B.C.
- 21 Lower seam, No. 4 mine, Comox Colliery, Wellington Colliery Co., Ltd., Cumberland, B.C.
- 21 SP Lower seam, No. 7 mine, Comox Colliery, Wellington Colliery Co., Ltd., Cumberland, B.C.
- 21 M Mixture of Nos. 4 and 7 mines, Comox Colliery, Wellington Colliery Co., Ltd., Cumberland, B.C.

ALERT BAY COAL FIELD, VANCOUVER ISLAND, B.C.

- Ex. 34 Suquash mine, Pacific Coast Coal Co., Alert bay, Vancouver island, B.C.

WHITEHORSE COAL FIELD, YUKON TERRITORY

- Ex. 31 Upper seam, Tantalus mine, White Pass and Yukon Railway Co., Ltd., Yukon.
- Ex. 32 Middle seam, Tantalus mine, White Pass and Yukon Railway Co., Ltd., Yukon.
- Ex. 33 Lower seam, Tantalus mine, White Pass and Yukon Railway Co., Ltd., Yukon.

TABLE LIV

SUMMARY RECORD OF ANALYSES OF COALS

SYDNEY COAL FIELD, CAPE BRETON COUNTY, N.S.

1. Source of coal—mine and seam.		North Atlantic Collieries, Gowrie Seam, Port Morien						Dominion Coal Co., Glace Bay, Hub Seam, Dominion No. 7.						Dominion Coal Co., Glace Bay, Harbour Seam, Dominion No. 9.						Dominion Coal Co., Glace Bay, Phalen Seam, Dominion No. 5, or Reserve Colliery.						Dominion Coal Co., Glace Bay, Phalen Seam, Dominion No. 1.						Dominion Coal Co., Glace Bay, Emery Seam, Dominion No. 10 Colliery.						Dominion Coal Co., Glace Bay, Lingan Seam, Dominion No. 12 Colliery.						Nova Scotia Steel & Coal Co., Sydney Mines, No. 1 Colliery.						Nova Scotia Steel & Coal Co., Sydney Mines, No. 3 Colliery.					
2. Description of sample.		Regular sample over 1/4" screen and picking belt	Regular sample over 2 1/2" screen and picking belt	Mine moisture sample	Boiler trial sample	Rescreened for producer trial	Washed coal	Boiler trial sample of washed coal	Fresh sample for coking tests	Regular sample over 2 1/2" screen and picking belt	Mine moisture sample	Boiler trial sample	Rescreened for producer trial	Fresh sample for coking test	Regular sample over 1 1/2" screen and picking belt	Mine moisture sample	Boiler trial sample	Rescreened for producer trial	Fresh sample for coking tests	Regular sample run of mine over picking belt	Mine moisture sample	Boiler trial sample	Screened for producer trial	Washed coal	Boiler trial sample of washed coal	Fresh sample for coking tests	Regular sample run of mine coal	Mine moisture sample	Fresh sample for coking test	Regular sample over 1/2" screen and picking belt	Mine moisture sample	Boiler trial sample	Washed coal	Boiler trial sample of washed coal	Fresh sample for coking test	Regular sample over 1/2" screen and picking belt	Mine moisture sample	Boiler trial sample	Rescreened for producer trial	Fresh sample for coking test															
3. Sample number.		50	36	136	336	736	236	536	2036	35	135	335	735	2035	35 SP	135 SP	2035 SP	38	138	338	738	2038	37	137	337	737	237	537	2037	39	139	2039	13	113	313	213	513	2013*	12	112	312	712	2012*												
4. Moisture in coal		2.8	3.5	2.7	2.4	4.5	3.4	2.4	1.8	1.4	2.1	3.4	1.9	3.5	2.8	2.2	1.8	4.0	2.8	2.1	4.5	4.1	4.9	4.3	3.5	2.3	3.3	1.6	5.4	4.2	3.6	3.5	2.7	4.0	5.4	4.2	3.6	3.5	4.0	5.4	4.2	3.6	3.5												
5. Total moisture, %		2.8	3.5	2.7	2.4	4.5	3.4	2.4	1.8	1.4	2.1	3.4	1.9	3.5	2.8	2.2	1.8	4.0	2.8	2.1	4.5	4.1	4.9	4.3	3.5	2.3	3.3	1.6	5.4	4.2	3.6	3.5	2.7	4.0	5.4	4.2	3.6	3.5	4.0	5.4	4.2	3.6	3.5												
6. Moisture left after air drying, %		2.8	3.5	2.7	2.4	4.5	3.4	2.4	1.8	1.4	2.1	3.4	1.9	3.5	2.8	2.2	1.8	4.0	2.8	2.1	4.5	4.1	4.9	4.3	3.5	2.3	3.3	1.6	5.4	4.2	3.6	3.5	2.7	4.0	5.4	4.2	3.6	3.5	4.0	5.4	4.2	3.6	3.5												
7. Proximate analysis of dry coal		53.0	57.6	59.1	59.1	58.3	55.5	53.3	54.9	59.5	58.2	59.8	60.2	60.4	53.8	53.9	57.3	58.5	57.9	58.8	55.4	56.3	52.6	51.3	55.3	48.4	53.8	53.5	37.3	58.8	37.4	56.3	52.6	51.3	55.3	48.4	53.8	53.5	37.3	58.8	37.4	56.3	52.6	51.3	55.3	48.4									
8. Fixed carbon (FC), by difference, %		34.7	36.5	35.8	38.2	37.2	38.6	35.6	38.2	35.0	35.2	34.3	33.2	34.8	35.1	34.8	36.9	35.5	37.1	37.3	37.2	37.2	40.2	39.0	36.6	34.8	35.1	34.8	36.9	35.5	37.1	37.4	40.2	39.0	36.6	34.8	35.1	34.8	36.9	35.5	37.1	37.4	40.2	39.0	36.6	34.8									
9. Volatile matter (VM), %		12.3	5.9	5.2	8.9	5.1	5.9	5.0	4.2	11.1	6.9	5.5	6.1	6.6	5.9	7.7	4.1	6.6	4.8	11.1	8.1	10.1	11.3	5.8	5.7	6.0	4.8	6.4	4.1	7.2	5.7	3.5	3.8	11.4	6.7	5.3	8.1	16.8	7.3	9.4	16.8	7.3	9.4	16.8	7.3	9.4	16.8								
10. Ash, %		70.5	76.7	80.0	78.2	77.0	76.0	78.6	78.3	78.6	80.2	73.3	78.5	79.3	77.6	80.4	75.4	79.3	72.6	74.9	75.4	79.3	72.6	74.9	67.4	77.6	80.4	75.4	79.3	72.6	74.9	67.4	77.6	80.4	75.4	79.3	72.6	74.9	67.4	77.6	80.4	75.4	79.3	72.6	74.9	67.4									
11. Carbon (C), %		4.8	5.0	5.2	5.2	5.2	5.2	5.3	4.9	5.2	5.3	5.3	5.2	5.3	4.9	5.2	5.2	5.3	4.9	5.2	5.2	5.3	5.2	5.3	4.9	5.2	5.2	5.3	4.9	5.2	5.2	5.3	4.9	5.2	5.2	5.3	4.9	5.2	5.2	5.3	4.9	5.2	5.2	5.3	4.9	5.2	5.2	5.3							
12. Hydrogen (H), %		4.8	5.0	5.2	5.2	5.2	5.2	5.3	4.9	5.2	5.3	5.3	5.2	5.3	4.9	5.2	5.2	5.3	4.9	5.2	5.2	5.3	5.2	5.3	4.9	5.2	5.2	5.3	4.9	5.2	5.2	5.3	4.9	5.2	5.2	5.3	4.9	5.2	5.2	5.3	4.9	5.2	5.2	5.3	4.9	5.2	5.2	5.3							
13. Sulphur, %		6.4	2.4	2.0	3.0	3.7	3.7	1.8	2.3	1.9	1.5	2.5	2.1	1.7	1.8	2.9	1.9	1.6	1.6	1.6	1.3	1.6	1.6	1.6	1.6	1.6	1.6	1.6	1.6	1.6	1.6	1.6	1.6	1.6	1.6	1.6	1.6	1.6	1.6	1.6	1.6	1.6	1.6	1.6	1.6	1.6	1.6	1.6							
14. Nitrogen, %		1.0	1.6	1.7	1.5	1.5	1.5	1.4	1.4	1.4	1.4	1.4	1.3	1.4	1.2	1.3	1.3	1.3	1.3	1.2	1.3	1.3	1.3	1.3	1.3	1.3	1.3	1.3	1.3	1.3	1.3	1.3	1.3	1.3	1.3	1.3	1.3	1.3	1.3	1.3	1.3	1.3	1.3	1.3	1.3	1.3	1.3	1.3							
15. Oxygen, by difference, %		5.0	8.4	8.4	7.6	6.7	6.7	6.7	6.7	6.7	6.7	6.7	6.7	6.7	6.7	6.7	6.7	6.7	6.7	6.7	6.7	6.7	6.7	6.7	6.7	6.7	6.7	6.7	6.7	6.7	6.7	6.7	6.7	6.7	6.7	6.7	6.7	6.7	6.7	6.7	6.7	6.7	6.7	6.7	6.7	6.7	6.7	6.7							
16. Caloric value of dry coal		7010	7700	7950	7840	7780	7780	7800	7780	7800	7780	7780	7780	7780	7780	7780	7780	7780	7780	7780	7780	7780	7780	7780	7780	7780	7780	7780	7780	7780	7780	7780	7780	7780	7780	7780	7780	7780	7780	7780	7780	7780	7780	7780	7780	7780	7780	7780							
17. —by determination, calories		7010	7700	7950	7840	7780	7780	7800	7780	7800	7780	7780	7780	7780	7780	7780	7780	7780	7780	7780	7780	7780	7780	7780	7780	7780	7780	7780	7780	7780	7780	7780	7780	7780	7780	7780	7780	7780	7780	7780	7780	7780	7780	7780	7780	7780	7780	7780							
18. — " " B.T.U.		12620	13860	14310	14040	14000	14040	14040	14040	14040	14040	14040	14040	14040	14040	14040	14040	14040	14040	14040	14040	14040	14040	14040	14040	14040	14040	14040	14040	14040	14040	14040	14040	14040	14040	14040	14040	14040	14040	14040	14040	14040	14040	14040	14040	14040	14040	14040	14040						
19. — " " calculated to ash free coal, calories		7990	8180	8170	8270	8270	8270	8250	8270	8250	8270	8250	8270	8250	8270	8250	8270	8250	8270	8250	8270	8250	8270	8250	8270	8250	8270	8250	8270	8250	8270	8250	8270	8250	8270	8250	8270	8250	8270	8250	8270	8250	8270	8250	8270	8250	8270	8250	8270						
20. —by calculation from ultimate analysis, calories		7290	7600	7920	7840	7830	7830	7920	7830	7920	7830	7920	7830	7920	7830	7920	7830	7920	7830	7920	7830	7920	7830	7920	7830	7920	7830	7920	7830	7920	7830	7920	7830	7920	7830	7920	7830	7920	7830	7920	7830	7920	7830	7920	7830	7920	7830	7920							
21. Ratio FC/VM.		1.53	1.58	1.65	1.55	1.57	1.44	1.50	1.44	1.70	1.65	1.74	1.55	1.55	1.53	1.55	1.55	1.61	1.55	1.58	1.48	1.40	1.46	1.39	1.51	1.39	1.47	1.43	1.47	1.43	1.47	1.43	1.47	1.43	1.47	1.43	1.47	1.43	1.47	1.43	1.47	1.43	1.47	1.43	1.47	1.43	1.47								
22. Ratio C/H.		14.7	15.3	15.4	15.4	15.0	14.8	14.6	14.8	14.8	14.8	14.8	14.8	14.8	14.8	14.8	14.8	14.8	14.8	14.8	14.8	14.8	14.8	14.8	14.8	14.8	14.8	14.8	14.8	14.8	14.8	14.8	14.8	14.8	14.8	14.8	14.8	14.8	14.8	14.8	14.8	14.8	14.8	14.8	14.8	14.8	14.8	14.8	14.8						

*These samples were slack coal furnished by Mr. Preston

TABLE LV.
SUMMARY RECORD OF ANALYSES OF COALS.

INVERNESS COAL FIELD, INVERNESS COUNTY, N.S.											
1. Source of coal—mine and seam.....	Inverness Coal & Railway Co., Inverness Colliery.					Richmond Railway Co., Port Hood Colliery. *					
	Regular sample over 3/4" screen and picking belt	Mine moisture sample	Boiler trial sample	Washed coal	Boiler trial sample of washed coal	Regular sample over 3/4" screen and picking belt	Mine moisture sample	Boiler trial sample	Rescreened coal for producer trial	Washed coal	Boiler trial sample of washed coal
2. Description of sample.....											
3. Sample number.....	14	114	314	214	514	15	115	315	715	215	515
4. Moisture in coal											
5. Total moisture.....%		9.3	7.3		9.2		4.7	3.3	2.8		5.5
5. Moisture left after air drying.....%		7.5					3.2				
6. Proximate analysis of dry coal											
6. Fixed carbon (FC), by difference.....%	49.6			51.0		48.3			50.0	51.2	
7. Volatile matter (VM).....%	40.0			42.5		37.1			36.3	37.9	
8. Ash.....%	10.4		9.3	6.5	6.5	14.6		14.7	13.7	10.9	10.1
9. Ultimate analysis of dry coal											
9. Carbon (C).....%	67.2			70.3		63.7				68.7	
10. Hydrogen (H).....%	4.8			4.8		4.2				4.4	
11. Sulphur.....%	6.0			5.0		7.9				6.7	
12. Nitrogen.....%	0.9			0.6		0.8				0.6	
13. Oxygen, by difference.....%	10.7			12.8		8.8				8.7	
14. Calorific value of dry coal											
14. —by determination.....calories	6750			7110		6540				6970	
15. — " ".....B.T.U.	12150			12800		11770				12550	
16. — " " calculated to ash free coal.....calories	7530			7610		7660				7820	
17. —by calculation from ultimate analysis.....calories	6770			6900		6390				6840	
18. Ratio FC/VM.....	1.24			1.20		1.30			1.38	1.35	
19. Ratio C/H.....	14.0			14.6		15.1				15.6	

TABLE LXVI

SUMMARY RECORD OF ANALYSES OF COALS

SIMILKAMEEN COAL FIELD, B.C.						
1. Source of coal—mine and seam.	Best bench, No. 1 Opening Granite Creek.		Best bench, No. 2 Opening Granite Creek.		Best bench, No. 4 Opening Granite Creek.	
	Regular sample	Washed coal	Regular sample	Washed coal	Regular sample	Washed coal
2. Description of sample.						
3. Sample number.	Ex. 1	Ex. 201	Ex. 2	Ex. 202	Ex. 3	Ex. 203
Moisture in coal						
4. Total moisture. %						
5. Moisture left after air drying. %	2.3		2.3		3.2	
Proximate analysis of dry coal						
6. Fixed carbon (FC), by difference. %	54.0		53.6		51.9	
7. Volatile matter (VM). %	33.7		32.4		32.1	
8. Ash. %	12.3	7.9	14.0	10.4	16.0	13.9
Ultimate analysis of dry coal						
9. Carbon (C). %	71.6		70.1		69.4	
10. Hydrogen (H). %	4.8		4.4		4.3	
11. Sulphur. %			1.9	1.8		
12. Nitrogen. %						
13. Oxygen, by difference. %						
Caloric value of dry coal						
14. —by determination. calories						
15. — “ “ B.T.U.						
16. — “ “ calculated to ash free coal, calories						
17. —by calculation from ultimate analysis. calories						
18. Ratio FC/VM.	1.60		1.65		1.61	
19. Ratio C/H.	14.9		15.9		16.1	

TABLE LVII.
SUMMARY RECORD OF ANALYSES OF COALS.

SPRINGHILL COAL FIELD, CUMBERLAND COUNTY, N.S.														
1. Source of coal—mine and seam.....	Cumberland Ry. & Coal Co., No. 1 Colliery, Springhill	Cumberland Railway & Coal Co., No. 2 Colliery, Springhill.							Cumberland Railway & Coal Co., No. 3 Colliery, Springhill.					
	Special sample for coking tests	Regular sample over ¾" screen and picking belt	Mine moisture sample	Boiler trial sample	Rescreened coal for producer trial	Washed coal	Boiler trial sample of washed coal	Fresh sample for coking test	Regular sample over ¾" screen and picking belt	Mine moisture sample	Boiler trial sample	Washed coal	Boiler trial sample of washed coal	Fresh sample for coking tests.
3. Sample number.....	49	5	105	305	705	205	505	2005	6	106	306	206	506	2006
4. Moisture in coal														
4. Total moisture.....%	2.2		2.8	1.9	1.9		3.8	2.5		2.8	2.2		3.4	2.4
5. Moisture left after air drying.....%			2.0							2.3				
6. Proximate analysis of dry coal														
6. Fixed carbon (FC), by difference.....%	63.3	58.5			61.2	59.8		62.0	55.0			57.0		61.6
7. Volatile matter (VM).....%	33.3	32.3			31.4	33.1		32.1	33.5			34.7		33.7
8. Ash.....%	3.4	9.2			7.4	7.1		5.9	11.5		11.9	8.3		7.7
9. Ultimate analysis of dry coal														
9. Carbon (C).....%	81.5	75.1				76.9		79.5	73.1			75.4		81.2
10. Hydrogen (H).....%	5.1	4.9				5.0		5.2	4.6			4.9		5.2
11. Sulphur.....%	1.0	1.6				1.4		0.9	1.8			1.5		0.9
12. Nitrogen.....%	1.9	1.2				1.0		2.0	1.8			1.4		1.8
13. Oxygen, by difference.....%	7.1	8.0				8.6		6.5	7.2			8.5		6.2
14. Calorific value of dry coal														
14. —by determination.....calories	7880	7430				7700		7710	7220			7540		
15. —" ".....B.T.U.	14190	13370				13860		13880	13000			13570		
16. —" " calculated to ash free coal.....calories	8160	8180				8290		8190	8160			8220		
17. —by calculation from ultimate analysis.....calories	8060	7450				7590		7964	7220			7440		8100
18. Ratio FC/VM.....	1.90	1.81			1.94	1.81		1.93	1.64			1.64		1.83
19. Ratio C/H.....	16.0	15.3				15.4		15.3	15.9			15.4		15.6

TABLE LVIII
SUMMARY RECORD OF ANALYSES OF COALS.

JOGGINS-CHIGNECTO COAL FIELD, CUMBERLAND COUNTY, N.S.

1. Source of coal—mine and seam.....	Maritime Coal, Railway, & Power Co., Chignecto Colliery					Minudie Coal Co., River Hebert, Minudie Colliery					Canada Coals & Railway Co., Joggins Colliery							
	Regular sample hand picked	Mine moisture sample	Boiler trial sample	Washed coal	Boiler trial sample of washed coal	Regular sample over 3/4" screen and picking belt	Mine moisture sample	Boiler trial sample	Washed coal	Boiler trial sample of washed coal	Regular sample over 3/4" screen and picking belt	Mine moisture sample	Boiler trial sample	Rescreened for producer trial	Washed coal	Boiler trial sample of washed coal	Supplementary sample	Extra fresh sample for coking tests
2. Description of sample.....																		
3. Sample number.....	7	107	307	207	507	9	109	309	209	509	10	110	310	710	210	510	2010	3010
4. Moisture in coal.....																		
5. Total moisture.....%		3.6	3.0		5.3		3.8	2.8		3.5		1.3	2.9	2.5		3.8		4.8
5. Moisture left after air drying.....%		3.2					2.8					0.6						
6. Proximate analysis of dry coal.....																		
6. Fixed carbon (FC), by difference.....%	45.7			49.6		48.8			51.7		44.8			46.1	51.6		46.5	50.1
7. Volatile matter (VM).....%	41.0			41.3		35.7			37.3		36.6			35.3	38.1		36.6	38.4
8. Ash.....%	13.3			9.1		15.5			11.0		18.6		16.8	18.6	10.3	9.9	16.9	11.5
9. Ultimate analysis of dry coal.....																		
9. Carbon (C).....%	66.2			70.0		64.8			68.2		63.5				70.3			68.8
10. Hydrogen (H).....%	4.8			5.0		4.4			4.6		4.1				4.9			4.9
11. Sulphur.....%	6.4			6.2		6.7			6.3		5.4				4.8		5.2	6.8
12. Nitrogen.....%	1.3			1.0		1.1			0.8		1.3				0.9		1.7	1.6
13. Oxygen, by difference.....%	8.0			8.7		7.5			9.1		7.1				8.8			6.4
14. Caloric value of dry coal.....																		
14. —by determination.....calories	6750			7160		6570			7000		6440				7080			
15. —" ".....B.T.U.	12150			12890		11830			12600		11590				12740			
16. —" " calculated to ash free coal.....calories	7790			7880		7780			7870		7910				7890			
17. —by calculation from ultimate analysis.....calories	6810			7140		6590			6860		6360				7100			7130
18. Ratio FC/VM.....	1.11			1.20		1.37			1.38		1.22		1.31	1.35		1.27		1.30
19. Ratio C/H.....	13.8			14.0		14.7			14.8		15.5			14.4				14.0

TABLE LIX
SUMMARY RECORD OF ANALYSES OF COALS.

GRAND LAKE COAL FIELD, N.B.						
1. Source of coal—mine and seam.	G. H. King, Kings Mine, Minto.					
2. Description of sample.	Regular sample over $\frac{3}{4}$ " screen	Mine moisture sample	Boiler trial sample	Rescreened coal for pro- ducer trial	Washed coal	Boiler trial sample of washed coal
3. Sample number.	11	111	311	711	211	511
Moisture in coal						
4. Total moisture. %		1.3	0.7	1.3		1.7
5. Moisture left after air drying. %		0.9				
Proximate analysis of dry coal						
6. Fixed carbon (FC), by difference. %	53.4			54.1	56.6	
7. Volatile matter (VM) %	32.2			33.0	34.0	
8. Ash %	14.4			12.9	9.4	
Ultimate analysis of dry coal						
9. Carbon (C) %	70.3				75.4	
10. Hydrogen (H) %	4.6				5.0	
11. Sulphur. %	5.8				4.9	
12. Nitrogen %	0.6				0.5	
13. Oxygen, by difference. %	4.3				4.8	
Calorific value of dry coal						
14. — by determination calories	7160				7680	
15. — " " B.T.U.	12890				13820	
16. — " " calculated to ash free coal calories	8360				8480	
17. — by calculation from ultimate analysis. . . calories	7220				7720	
18. Ratio FC/VM.	1.66			1.64	1.66	
19. Ratio C/H.	15.3				15.1	

TABLE LX

SUMMARY RECORD OF ANALYSES OF COALS.

SOURIS COAL FIELD, SASKATCHEWAN.									
1. Source of coal—mine and seam.	Western Dominion Collieries Co., Taylorton						Eureka Coal and Brick Co., Estevan.		
2. Description of sample.	Regular sample run of mine coal	Mine moisture sample	Boiler trial sample	Supplementary sample run of mine coal	Screened for producer trial No. 8	Screened for producer trial No. 17	Regular sample run of mine coal	Mine moisture sample	Screened for producer trial
3. Sample number.	40	140	340	2040	2740 (a)*	2740 (b)*	41	141	741
4. Moisture in coal									
5. Total moisture.		28.6	29.7		23.3	13.4		30.9	17.8
5. Moisture left after air drying %		18.0						18.2	
6. Proximate analysis of dry coal									
6. Fixed carbon (FC), by difference. %	42.9			47.9	48.8	37.6	43.2		49.2
7. Volatile matter (VM). %	49.0			42.7	42.7	49.8	40.0		35.5
8. Ash. %	8.1	11.4	8.6	9.4	8.5	12.6	16.8	14.1	15.3
9. Ultimate analysis of dry coal									
9. Carbon (C). %	59.8			64.7			57.7		
10. Hydrogen (H). %	4.8			4.5			4.3		
11. Sulphur. %	0.6			0.7			0.5		
12. Nitrogen. %	1.0			1.1			1.0		
13. Oxygen, by difference. %	25.7			19.6			19.7		
14. Calorific value of dry coal									
14. — by determination. . calories	5940			6010			5360		
15. — " " . . . B.T.U.	10690			10820			9650		
16. — " " . . . calculated									
16. to ash free coal. . . calories	6470			6630			6440		
17. —by calculation from ultimate analysis. calories..	5400			5930			5290		
18. Ratio FC/VM.	0.88			1.12	1.15	0.75	1.08		1.38
19. Ratio C/H.	12.5			14.4			13.4		

*A period of seven weeks intervened between these two trials during which sample (6) lost moisture.

TABLE LXI
SUMMARY RECORD OF ANALYSES OF COALS.

EDMONTON COAL FIELD, ALTA.											
1. Source of coal—mine and seam.....	Strathcona Coal Co., Strathcona.			Parkdale Coal Co., Edmonton.					Standard Coal Co., (formerly the City Coal Co.) Edmonton.		
	Regular sample over 1½" screen	Mine moisture sample	Rescreened for producer trial	Regular sample over 1½" screen	Mine moisture sample	Boiler trial sample	Rescreened for producer trial No. 9	Rescreened for producer trial No. 15	Regular sample over 1½" screen	Mine moisture sample	Rescreened for producer trial
3. Sample number.....	46	146	746	42	142	342	742 (a)*	742 (b)	45	145	745
4. Moisture in coal											
4. Total moisture.....%		22.7	16.1		22.5	19.7	14.9	13.6		23.5	15.3
5. Moisture left after air drying.....%		18.2			18.9					19.8	
Proximate analysis of dry coal											
6. Fixed carbon (FC), by difference.....%	47.6		49.0	51.3			52.1	51.8	49.9		54.4
7. Volatile matter (VM).....%	41.0		36.8	37.8			34.9	34.6	42.0		36.8
8. Ash.....%	11.4	7.1	14.2	10.9	6.8	12.6	13.0	13.6	8.1	5.0	8.8
Ultimate analysis of dry coal											
9. Carbon (C).....%	62.9			65.3					65.6		
10. Hydrogen (H).....%	4.5			4.6					4.5		
11. Sulphur.....%	0.4			0.4					0.4		
12. Nitrogen.....%	1.3			1.2					1.3		
13. Oxygen, by difference.....%	19.5			17.6					20.1		
Calorific value of dry coal											
14. —by determination.....calories	5960			6060					6310		
15. —" ".....B.T.U.	10730			10910					11360		
16. —" " calculated to ash free coal.....calories	6730			6800					6870		
17. —by calculation from ultimate analysis.....calories	5820			6110					6000		
18. Ratio FC/VM.....	1.16		1.33	1.36			1.49	1.50	1.19		1.48
19. Ratio C/H.....	14.0			14.2					14.6		

*This sample was taken some weeks before sample 742(b) and therefore shows more moisture. The trial in the producer was unsatisfactory and is not reported.

TABLE LXII
SUMMARY RECORD OF ANALYSES OF COALS.

BELLY RIVER COAL FIELD, ALTA.										
1. Source of coal—mine and seam.....	Canada West Coal Co., Taber.				Alberta Railway & Irrigation Co., Galt Colliery, Lethbridge.				Lund-Breckenridge Coal Co., Lundbreck.	
	Regular sample over 3/4" screen	Mine moisture sample	Boiler trial sample	Rescreened for producer trial	Regular sample over 3/4" screen and picking table	Mine moisture sample	Boiler trial sample	Rescreened for producer trial	Regular sample	Mine moisture sample
2. Description of sample										
3. Sample number.	43	143	343	743	44	144	344	744	47	147
4. Moisture in coal										
5. Total moisture.....%		13.0	11.3	12.6		8.4	8.3	7.8		5.0
5. Moisture left after air drying.....%		11.7				7.9				3.8
6. Proximate analysis of dry coal										
7. Fixed carbon (FC), by difference.....%	49.9			50.8	51.5			51.6	40.2	
7. Volatile matter (VM).....%	36.0			30.5	37.5			38.2	30.1	
8. Ash.....%	14.1	12.4	14.2	18.7	11.0	10.3	9.9	10.2	29.7	20.7
9. Ultimate analysis of dry coal										
9. Carbon (C).....%	64.5				66.5				54.8	
10. Hydrogen (H).....%	4.7				4.9				4.1	
11. Sulphur.....%	1.4				0.8				1.2	
12. Nitrogen.....%	1.5				1.7				1.5	
13. Oxygen, by difference.....%	13.8				15.1				8.7	
14. Calorific value of dry coal										
14. —by determination.....calories	6130				6510				5450	
15. —" ".....B.T.U.	11040				11710				9810	
16. —" " calculated to ash free coal.....calories	7140				7310				7750	
17. —by calculation from ultimate analysis.....calories	6278				6430				5490	
18. Ratio FC/VM.....	1.39			1.66	1.37			1.35	1.33	
19. Ratio C/H.....	13.7				13.6				13.4	

TABLE LXV
SUMMARY RECORD OF ANALYSES OF COALS.

CASCADE COAL FIELD, ALTA.																					
1. Source of coal—mine and seam.....		The H. W. McNeil Co., No. 1, or Old Mine, Canmore.						Bankhead Collieries, Ltd., Bankhead Colliery.		Bankhead Collieries, Ltd., Bankhead Colliery.		Bankhead Collieries Ltd., Bankhead Colliery.						Bankhead Collieries Ltd., Bankhead Colliery.			
2. Description of sample.....		Regular sample run of mine coal over picking belt	Mine moisture sample	Boiler trial sample	Screened for producer trial No. 37	Screened for producer trial No. 38	Washed coal	Boiler trial sample of washed coal	Regular sample pea coal through $\frac{3}{4}$ " and over $\frac{1}{4}$ " screens and over slater and picker	Mine moisture sample	Regular sample, buckwheat No. 1 coal, through $\frac{1}{4}$ " and over $\frac{1}{8}$ " screens, and over slater	Mine moisture sample	Regular sample mixture of 23 and 23 SP.	Boiler trial sample	Rescreened for producer trial No. 41	Rescreened for producer trial No. 43	Washed coal	Boiler trial sample of washed coal	Regular sample coal dust briquettes	Special moisture sample	Boiler trial sample
3. Sample number.....		25	125	325	725 (a)	725 (b)	225	525	23	123	23 SP	123 SP	23 M	323 M	723 M (b)	723 M (b)	223 M	523 M	24	124	324
4. Moisture in coal.....																					
5. Total moisture.....%			1.2	0.8	0.8	0.7		4.3		1.0		1.1		0.6	0.9	0.9		2.7		2.7	0.7
6. Moisture left after air drying.....%			0.9							0.5		0.5								0.9	
7. Proximate analysis of dry coal.....																					
8. Fixed carbon (FC), by difference.....%		70.5			71.2	70.7	77.9		76.0		71.5		73.3		78.5	77.6	78.6		68.6		
9. Volatile matter (VM).....%		17.2			15.7	16.8	16.2		11.8		12.6		12.6		11.5	11.3	12.5		17.1		
10. Ash.....%		12.3	13.9	8.8	13.1	12.5	5.9	6.2	12.2	12.2	15.9	15.0	14.1	15.5	10.0	11.1	8.9	8.7	14.3	12.5	14.1
11. Ultimate analysis of dry coal.....																					
12. Carbon (C).....%		74.6					85.2		79.4		76.0		76.6				81.8		76.3		
13. Hydrogen (H).....%		3.8					4.1		3.6		3.7		3.6				3.8		3.7		
14. Sulphur.....%		0.8					0.7		0.6		0.6		0.6				0.6		0.6		
15. Nitrogen.....%		1.6					1.7		1.0		0.9		1.0				1.1		1.0		
16. Oxygen, by difference.....%		6.9					2.4		3.2		2.9		4.1				3.8		4.1		
17. Caloric value of dry coal.....																					
18. —by determination.....calories		7340					8000		7400		7040		7270				7760		7280		
19. — " ".....B.T.U.		13210					14400		13,320		12670		13080				13970		13100		
20. — " " calculated to ash free coal.....calories		8370					8500		8430		8370		8460				8520		8490		
21. —by calculation from ultimate analysis.....calories		7040					8220		7530		7290		7300				7760		7280		
22. Ratio FC/VM.....		4.10			4.53	4.21	4.80		6.44		5.68		5.82		6.82	6.86	6.29		4.01		
23. Ratio C/H.....		19.6					20.8		22.0		20.6		21.3				21.5		20.6		

TABLE LXVII
SUMMARY RECORD OF ANALYSES OF COALS.

NICOLA VALLEY COAL FIELD, B.C.										
1. Source of coal—mine and seam.....	Nicola Valley Coal & Coke Co., Coutlee, No. 1 Mine, Middlesboro Colliery, Jewel Seam		Nicola Valley Coal & Coke Co., Coutlee, No. 2 Mine, Middlesboro Colliery		Nicola Valley Coal & Coke Co., Coutlee, Mines 1 and 2, Middlesboro Colliery					
2. Description of sample.....	Regular sample run of mine coal	Mine moisture sample	Regular sample run of mine coal	Mine moisture sample	Regular sample mixture of 140 bags 22 and 10 bags 22SP	Boiler trial sample	Screened for producer trial No. 18	Screened for producer trial No. 25	Washed coal	Boiler trial sample of washed coal
3. Sample number.....	22	122	22 SP	122 SP	22 M	322 M	722 M(a)	722 M(b)	222 M	522 M
4. Moisture in coal										
5. Total moisture.....%		4.4		2.9		4.8	3.2	4.2		6.2
5. Moisture left after air drying.....%		3.9		2.3						
6. Proximate analysis of dry coal										
7. Fixed carbon (FC), by difference.....%	46.4		48.1		46.8		49.4	49.0	50.2	
7. Volatile matter (VM).....%	39.1		39.0		39.1		37.4	38.5	39.8	
8. Ash.....%	14.5	12.7	12.9	11.4	14.1	16.2	13.2	12.5	10.0	9.9
9. Ultimate analysis of dry coal										
10. Carbon (C).....%	67.2		69.4		66.1				70.8	
11. Hydrogen (H).....%	5.0		5.1		4.9				5.3	
11. Sulphur.....%	0.9		0.7		0.9				0.9	
12. Nitrogen.....%	1.3		2.0		1.4				1.5	
13. Oxygen, by difference.....%	11.1		9.9		12.6				11.5	
14. Calorific value of dry coal										
15. —by determination.....calories	6490		6760		6510				7010	
15. — " ".....B.T.U.	11680		12170		11720				12620	
16. — " " calculated to ash free coal.....calories	7590		7760		7580				7790	
17. —by calculation from ultimate analysis.....calories	6690		6970		6500				7090	
18. Ratio FC/VM.....	1.19		1.23		1.20		1.32	1.27	1.26	
19. Ratio C/H.....	13.4		13.6		13.5				13.4	

TABLE LXVIII
SUMMARY RECORD OF ANALYSES OF COALS.

NANAIMO-COMOX COAL FIELD, VANCOUVER ISLAND, B.C.																			
1. Source of coal—mine and seam.....	Wellington Colliery Co., Extension, Extension Mine, Wellington Seam.				Western Fuel Co., Nanaimo, No. 1 Mine, Upper Seam or South Side Coal.					Western Fuel Co., Nanaimo, No. 1 Mine, No. 1 North Level, Lower Seam.				Wellington Colliery Co., No. 4 Mine, Lower Seam	Wellington Colliery Co., No. 7 Mine, Lower Seam,	Wellington Colliery Co., Cumberland-Comox District, Mines 4 and 7, Lower Seam.			
	Regular sample over 1½" screen and picking belt	Mine moisture sample	Boiler trial sample	Fresh sample for coking tests	Regular sample over 2" screen and picking belt	Mine moisture sample	Boiler trial sample	Rescreened for producer trial	Fresh sample for coking tests	Regular sample over 2" screen and picking belt	Mine moisture sample	Boiler trial sample	Rescreened for producer trial	Regular sample over ¾" screen and picking belt	Regular sample over ¾" to 1" screen and picking belt	Regular Sample Mixture of 21 and 21 SP	Boiler trial sample	Washed coal	Boiler trial sample of washed coal
2. Description of sample.....	20	120	320	2020	18	118	318	718	2018	17	117	317	717	21	21 SP	21 M	321 M	221 M	521 M
3. Sample number.....																			
4. Moisture in coal																			
5. Total moisture.....%		1.8	1.4	1.2		2.2	2.3	1.5	1.8		2.4	2.1	2.0				1.0		3.0
6. Moisture left after air drying.....%		1.1				1.6					1.9								
7. Proximate analysis of dry coal																			
8. Fixed carbon (FC), by difference.....%	49.8			51.0	48.5			45.1	48.1	46.6			42.4	56.5	60.1	57.8		60.3	
9. Volatile matter (VM).....%	40.1			40.4	41.2			41.0	41.5	41.5			40.5	31.6	28.0	30.2		30.8	
10. Ash.....%	10.1	8.6	9.0	8.6	10.3	10.8	10.1	13.9	10.4	11.9	19.2	14.6	17.1	11.9	11.9	12.0	11.7	8.9	8.9
11. Ultimate analysis of dry coal																			
12. Carbon (C).....%	72.9				72.1					69.0				72.9	74.4	73.4		77.6	
13. Hydrogen (H).....%	4.7				4.8					4.6				4.4	4.5	4.4		4.6	
14. Sulphur.....%	0.4			0.5	0.9				0.9	1.3				1.0	0.9	0.9		0.8	
15. Nitrogen.....%	1.2				1.2					1.2				1.0	1.0	1.0		1.1	
16. Oxygen, by difference.....%	10.7				10.7					12.0				8.8	7.3	8.3		7.0	
17. Calorific value of dry coal																			
18. —by determination.....calories	7310			7430	7130				7080	6930				7150	7210	7230		7550	
19. — " ".....B.T.U.	13160			13370	12830				12740	12470				12870	12980	13010		13590	
20. — " " calculated to ash free coal.....calories	8130			8130	7950				7900	7870				8120	8180	8220		8290	
21. —by calculation from ultimate analysis.....calories	7040				7020					6680				7050	7270	7120		7560	
22. Ratio FC/VM.....	1.24			1.26	1.18			1.10	1.16	1.12			1.05	1.79	2.14	1.91		1.96	
23. Ratio C/H.....	15.5				15.0					15.0				16.5	16.5	16.7		16.9	

TABLE LXIX
SUMMARY RECORD OF ANALYSES OF COALS.

ALERT BAY COAL FIELD, VANCOUVER ISLAND, B.C.

1. Source of coal—mine and seam	Pacific Coast Coal Co., Suquash Mine, Alert Bay	
2. Description of sample	Regular sample	Washed coal
3. Sample number	Ex. 34	Ex. 234
Moisture in coal		
4. Total moisture	%
5. Moisture left after air drying.....	%	7.0
Proximate analysis of dry coal		
6. Fixed carbon (FC) by difference.....	%	42.7
7. Volatile matter (VM).....	%	34.3
8. Ash	%	23.0
Ultimate analysis of dry coal		
9. Carbon (C)	%
10. Hydrogen (H)	%
11. Sulphur	%	1.0
12. Nitrogen.....	%
13. Oxygen, by difference	%
Calorific value of dry coal		
14. —by determination	calories	*6170
15. —“ “	B.T.U.	*11100
16. —“ “ calculated to ash free coal.....	calories	*8010
17. —by calculation from ultimate analysis.....	calories
18. Ratio FC/VM	1.24	1.31
19. Ratio C/H.....

*Determinations made with Parr calorimeter.

TABLE LXX
SUMMARY RECORD OF ANALYSES OF COALS

WHITEHORSE COAL FIELD, YUKON TERRITORY.						
1. Source of coal—mine and seam.	White Pass and Yukon Ry. Co., Tantalus Mine, Upper Seam		White Pass and Yukon Ry. Co., Tantalus Mine, Middle Seam		White Pass and Yukon Ry. Co., Tantalus Mine, Lower Seam	
	Regular sample	Washed coal	Regular sample	Washed coal	Regular sample	Washed coal
2. Description of sample.						
3. Sample number.	Ex. 31	Ex. 231	Ex. 32	Ex. 232	Ex. 33	Ex. 233
Moisture in coal						
4. Total moisture. %						
5. Moisture left after air drying. %						
Proximate analysis of dry coal						
6. Fixed carbon (FC), by difference %	58.0	59.9	54.1	60.3	56.0	59.2
7. Volatile matter (VM). %	25.0	26.3	26.7	25.7	27.8	28.1
8. Ash. %	17.0	13.8	19.2	14.0	16.2	12.7
Ultimate analysis of dry coal						
9. Carbon (C) %	69.8				71.1	
10. Hydrogen (H). %	4.0				4.3	
11. Sulphur %	0.5	0.5	0.5	0.4	0.5	0.5
12. Nitrogen. %	0.8	0.8	0.9	0.8	0.7	0.8
13. Oxygen, by difference. %	7.9				7.2	
Calorific value of dry coal						
14. —by determination calories	6700	7110	6310	7070	6790	7210
15. — “ “ B.T.U.	12060	12800	11360	12730	12230	12980
16. — “ “ calculated to ash free coal, calories	8070	8250	7810	8220	8100	8260
17. —by calculation from ultimate analysis. calories	6690				6930	
18. Ratio FC/VM.	2.32	2.28	2.03	2.34	2.02	2.10
19. Ratio C/H.	17.5				16.5	

TABLE LXXI
SUMMARY RECORD OF ANALYSES OF COALS.

STANDARD COAL USED FOR COMPARISON.			
1. Source of coal—mine and seam	Georges Creek Coal		
2. Description of sample	Boiler trial sample from trial No. 1	Boiler trial sample from trial No. 68	Boiler trial sample from trial No. 71
3. Sample number	G A	G B	Ex. 35
Moisture in coal			
4. Total moisture %	1.9	2.9	2.0
5. Moisture left after air drying %
Proximate analysis of dry coal			
6. Fixed carbon (FC), by difference %	71.2
7. Volatile matter (VM) %	19.6
8. Ash %	9.2	12.6	11.2
Ultimate analysis of dry coal			
9. Carbon (C) %
10. Hydrogen (H) %
11. Sulphur %	1.0	1.0
12. Nitrogen %
13. Oxygen, by difference %
Calorific value of dry coal			
14. —by determination calories	7820	7470	*7660
15. —" " B.T.U.	14080	13450	*13790
16. —" " calculated to ash free coal .calories	8610	8550	*8630
17. —by calculation from ultimate analysis .calories
18. Ratio FC/VM	3.63
19. Ratio C/H

* Determined with Parr calorimeter.

INDEX

VOL. II

INDEX

	PAGE		PAGE
A			
Acadia Coal Co., coals tested.....	42, 108	Calorific value, calculated from an-	
Air used for combustion in boiler		alysis of coal	155
tests.....	14	" " calculated from an-	
Alberta Railway and Irrigation Co.		" " alysis of gas	168
Ltd., coal tested.....	45, 110	" " gaseous fuels.....	165
American Chemical Society, method		" " solid fuels.....	146
of determining oxygen in coal	145	Campbell, M. R., carbon-hydrogen	
American Chemical Society, method		classification of coal.....	156
of determining amount of fixed		Campbell, W. B.....	122
carbon and volatile matter..	134	Canada Coal and Railway Co., Ltd.,	
Analysis of producer gas with Bone		coals tested	44
and Wheeler apparatus.....	161	" West Coal Co., coal tested.	45, 110
Analysis of producer gas with Ran-		Carbon and hydrogen in coal, how	
dall and Barnhart apparatus..	161	determined.....	136
Analytical methods and derived		" hydrogen ratio	156
results.....	131	Cascade coal field, coals tested....	85, 115
Apparatus in chemical laboratory.	131	Chemical laboratory, work of.....	121
Ash, determination of	178	" tests, records how kept..	129
" in coal	6	Chlorine, effect of in coal.	6
" samples, how obtained.	126	Clinkers, formation of	6, 59
" " how tested.....	136	Coal, air drying.....	130
Ashes, experiments on fusibility of	174	" analysis, difficult problems of	176
Atwater and Snell, use of bomb		" anthracites, Crowsnest and	
calorimeter.....	155	Alberta, good results from.	118
B			
Babcock and Wilcox boiler used in		" bituminous, effect of in gas	
test	15	producer.....	62
Ball mill for grinding samples, ad-		" " Nicola valley and	
vantages of	178	Nanaimo coal	
Bankhead Mines, Ltd., coals tested	48, 115	fields	117
Beckmann thermometer	147	" " Springhill and	
Belly River coal fields, coal from		Joggins field..	109
tested	110	" caking of	7
Boehner, R. S.....	122	" calorific value calculated from	
Boiler and plant, description of		analysis.	155
that used in tests	15	" calorific value of ash free.	155
Boiler tests,	3, 9	" carbon hydrogen ratio.	156
" " conditions governing	12	" composition of	32
" " method of conducting	18	" condition of when tested.	33
" " remarks on.	32	" determination of volatile mat-	
" " results of.	12	ter in	178
" " sources of error in	9	" economic value of samples	
Boilers, types of and efficiency	3	tested	35
Bone and Wheeler gas analysing		" fuel ratio of.	156
apparatus.....	161	" lignites, mixed, special trial.	112
Boys, Prof. C. V., gas calorimeter.	165	" mechanical strength and hard-	
Briquettes for determining calorific		ness of.	7
value.	178	" relative merit of	34
" from Bankhead coal		" soluble matter in.	173
tested.....	48	" specific gravity of.	173
" from coal samples.....	148	" suitability of for steam gen-	
" used in Koerting gas		erating.....	5
producer.	63	" treatment and behaviour of	
British Thermal Unit, definition	5	in fire.....	39
C			
Calculations for boiler trial.	27	" trials of Georges Creek coal..	36
Calorific tests, explanatory notes	152	" value of different kinds for	
" " method of recording		steam purposes	32
readings and calculations of		Coals, relative merit of, gas pro-	
determinations.....	151	ducer work.....	107
Calorific value, ash free coal.	155	" remarks on as arranged geo-	
		graphically.	40, 107
		" tested, list of	181
		" value of for gas producer	
		work.....	102

	PAGE		PAGE
Moisture in coal, effect of.....	6		
" " samples, how calculated	134	S	
" " steam.....	13, 16	Samples, collection and treatment	
Mond process gas producer.....	65	of.....	122
Morrison, H. G.....	122	" numbering of.....	127
N		Sample tubes, use of.....	178
Nanaimo coal field, coal tested....	117	Simmance-Abady recorder.....	17
Nanaimo-Comox and Alert Bay		Soluble matter in coal.....	173
coal fields, coal tested.....	50	" " " water.....	173
Nicola Valley Coal and Coke Co.,		Souris, Edmonton and Belly River	
coal tested.....	49, 117	coal fields, coal tested.....	45, 110
" " coal field, coal tested	49, 117	Specific gravity of coal.....	173
Nicolls, J. H. H.....	122	Split volatile ratio.....	156
Nitrogen, determination of.....	143	Springhill coal field, tests of coal	
Nova Scotia Steel and Coal Co.,		from.....	43
coal from tested.....	107	" and Joggins coal fields,	
Nova Scotia Steel and Coal Co.,		coal from tested.....	109
remarks on samples from.....	40	Staff, gas producer tests, duties of.	80
O		Standard Coal Co., coals from tested	110
Orsat-Muncke apparatus.....	158	Stansfield, A., furnace designed by	175
Oxygen, determination in coal....	145	" Edgar, description of	
P		" gas pressure regulator	132
Pacific Coast Coal Co., Ltd., coals		" " report on work of	
tested.....	50	the chemical labora-	
Parkdale Coal Co., coal tested....	45, 110	tory.....	121
Peabody throttling calorimeter....	16	Stoker, mechanical.....	11, 15
Pictou coal field, tests of coal from	42, 108	Strathcona Coal Co., coal from	
Poisoning from producer gas, reme-		tested.....	110
dy for.....	60	Suction gas producer.....	58
Pollard, Dr. W., methods of ash		Sulphur, determination of.....	140
determinations.....	179, 180	" effect of in coal.....	6
Port Hood colliery, coal from tested	108	Summary of observations.....	23
Power and Machinery Co.'s twin		" " results.....	26
producers.....	64	Sydney coal field, coals from tested	107
Producer gas.....	55	T	
" " hydrogen, sulphide		Tables, list of in this report.....	Table of
and sulphur dioxide			contents
in.....	173	Thermometers used in tests.....	18
" " relative merits of		Thomlinson, J. C., method for test-	
samples for tests ..	177	ing producer gas.....	173
R		W	
Radiation losses in boiler tests....	14	Washing, effect of on Pictou coal.	42
Randall and Barnhart apparatus..	158	Wellington Colliery Co., Ltd., coals	
Records and calculations, how		tested.....	50
made and kept.....	129	Welsh coal, comparison with.....	35
Richmond Railway and Coal Co.,		West Canadian Collieries Co., coals	
coal tested.....	41, 108	tested.....	46
Ruston, Proctor and Co., Ltd., gas		Western Dominion Collieries, Ltd.,	
producer, description of.....	58	coal tested.....	45, 110
		Western Fuel Co., Ltd., coals tested	50, 117
		Westinghouse double zone gas pro-	
		ducer.....	64
		Wilson producer gas plant.....	66

CANADA
DEPARTMENT OF MINES

MINES BRANCH

HON. W. TEMPLEMAN, MINISTER; A. P. LOW, LL.D., DEPUTY MINISTER;
EUGENE HAANEL, PH.D., DIRECTOR.

REPORTS AND MAPS OF ECONOMIC INTEREST.

PUBLISHED BY THE

MINES BRANCH

REPORTS.

1. Mining Conditions of the Klondike, Yukon. Report on—by Eugene Haanel, Ph.D., 1902.
2. Great Landslide at Frank, Alta. Report on—by R. G. McConnell and R. W. Brock, M.A., 1903.
3. Investigation of the different electro-thermic processes for the smelting of iron ores, and the making of steel, in operation in Europe. Report of Special Commission—by Eugene Haanel, Ph.D., 1904. (Out of print).
4. Rapport de la Commission nommée pour étudier les divers procédés électro-thermiques pour la réduction des minerais de fer et la fabrication de l'acier employés en Europe. (French Edition), 1905. (Out of print).
5. On the location and examination of magnetic ore deposits by magnetometric measurements. Eugene Haanel, Ph.D., 1904.
7. Limestones, and the Lime Industry of Manitoba. Preliminary Report on—by J. W. Wells, 1905.
8. Clays and Shales of Manitoba: their Industrial Value. Preliminary Report on—by J. W. Wells, 1905. (Out of print).
9. Hydraulic Cements (Raw Materials) in Manitoba; Manufacture and Uses of. Preliminary Report on—by J. W. Wells, 1905.
10. Mica: its Occurrence, Exploitation, and Uses—by Fritz Cirkel, M.E., 1905. (Out of print).
11. Asbestos: Its Occurrence, Exploitation, and Uses—by Fritz Cirkel, M.E., 1905. (Out of print: see No. 69)
12. Zinc Resources of British Columbia and the Conditions affecting their Exploitation. Report of the Commission appointed to investigate—by W. R. Ingalls, 1905.
16. Experiments made at Sault Ste. Marie, under Government auspices, in the smelting of Canadian iron ores by the electro-thermic process. Final Report on—by Eugene Haanel, Ph.D., 1907.
17. Mines of the Silver-Cobalt Ores of the Cobalt district: Their Present and Prospective Output Report on—by Eugene Haanel, Ph.D., 1907.
18. Graphite; Its Properties, Occurrence, Refining, and Uses—by Fritz Cirkel, M.E., 1907.
19. Peat and Lignite: Their Manufacture and Uses in Europe—by Erik Nyström, M.E., 1908.
20. Iron Ore Deposits of Nova Scotia. Report on (Part I)—by Dr. J. E. Woodman.
21. Summary Report of Mines Branch, 1907-8

22. Iron Ore Deposits of Thunder Bay and Rainy River districts. Report on—by F. Hille, M.E.
23. Iron Ore Deposits, along the Ottawa (Quebec side) and Gatineau rivers. Report on—by Fritz Cirkel, M.E.
24. General Report on the Mining and Metallurgical Industries of Canada, 1907-8.
25. The Tungsten Ores of Canada. Report on—by Dr. T. L. Walker.
26. The Mineral Production of Canada, 1906. Annual Report on—by John McLeish, B.A.
27. The Mineral Production of Canada, 1908. Preliminary Report on—by John McLeish, B.A.
28. Summary Report of Mines Branch, 1908.
29. Chrome Iron Ore Deposits of the Eastern Townships. Monograph on—by Fritz Cirkel, M.E. (Supplementary Section: Experiments with Chromite at McGill University—by Dr. J. B. Porter).
30. Investigation of the Peat Bogs and Peat Fuel Industry of Canada, 1908. Bulletin No. 1—by Erik Nyström, M.E., and A. Anrep, Peat Expert.
31. Production of Cement in Canada, 1908. Bulletin on—by John McLeish, B.A.
32. Investigation of Electric Shaft Furnace, Sweden. Report on—by Eugene Haanel, Ph.D.
42. Production of Iron and Steel in Canada during the calendar years 1907 and 1908. Bulletin on—by John McLeish, B.A.
43. Production of Chromite in Canada during the calendar years 1907 and 1908. Bulletin on—by John McLeish, B.A.
44. Production of Asbestos in Canada during the calendar years 1907 and 1908. Bulletin on—by John McLeish, B.A.
45. Production of Coal, Coke, and Peat in Canada during the calendar years 1907 and 1908. Bulletin on—by John McLeish, B.A.
46. Production of Natural Gas and Petroleum in Canada during the calendar years 1907 and 1908. Bulletin on—by John McLeish, B.A.
47. Iron Ore Deposits of Vancouver and Texada islands. Report on—by Einar Lindeman, M.E.
55. Report on the Bituminous, or Oil-shales of New Brunswick and Nova Scotia; also on the Oil-shale Industry of Scotland—by Dr. R. W. Ells.
58. The Mineral Production of Canada, 1907 and 1908. Annual Report on—by John McLeish, B.A.
59. Chemical Analyses of Special Economic Importance made in the Laboratories of the Department of Mines, 1906-7-8. Report on—by F. G. Wait, M.A., F.C.S. (With Appendix on the Commercial Methods and Apparatus for the Analysis of Oil-shales—by H. A. Leverin, Ch.E.)
62. Mineral Production of Canada, 1909. Preliminary Report on—by John McLeish, B.A.
63. Summary Report of Mines Branch, 1909.
67. Iron Ore Deposits of the Bristol Mine, Pontiac county, Québec. Bulletin No. 2—by Einar Lindeman, M.E., and Geo. C. Mackenzie, B.Sc.
Schedule of Charges for Chemical Analysis and Assays.
- [68. Recent Advances in the Construction of Electric Furnaces for the Production of Pig Iron, Steel, and Zinc. Bulletin No. 3—by Dr. Eugene Haanel.
69. Chrysotile-Asbestos: Its Occurrence, Exploitation, Milling, and Uses. Report on—by Fritz Cirkel, M.E. (Second Edition, enlarged).
71. Investigation of the Peat Bogs, and Peat Industry of Canada, 1909-10; to which is appended Mr. Alf. Larson's Paper on Dr. M. Ekenberg's Wet-Carbonizing Process: from Teknisk Tidskrift, No. 12, December 26, 1908—translation by Mr. A. Anrep, Jr.; also a translation of Lieut. Ekelund's Pamphlet entitled 'A Solution of the Peat Problem,' 1909, describing the Ekelund Process for the Manufacture of Peat Powder, by Harold. A. Leverin, Ch.E. Bulletin No. 4—by A. Anrep, Peat Expert. (Second Edition, enlarged).
79. Production of Iron and Steel in Canada during the calendar year 1909. Bulletin on—by John McLeish, B.A.
80. Production of Coal and Coke in Canada during the calendar year, 1909. Bulletin on—by John McLeish, B.A.

82. Magnetic Concentration Experiments. Bulletin No. 5—by Geo. C. Mackenzie.
83. An investigation of the Coals of Canada with reference to their Economic Qualities: as conducted at McGill University under the authority of the Dominion Government. Report on—by J. B. Porter, E.M., D.Sc., and others—
 Vol. I—Coal Washing and Coking Tests.
 Vol. II—Boiler and Gas Producer Tests.
84. Gypsum Deposits of the Maritime Provinces of Canada—including the Magdalen islands. Report on—by W. F. Jennison, M.E.
85. Production of Cement, Lime, Clay Products, Stone, and other Structural Materials during the calendar year 1909. Bulletin on—by John McLeish, B.A.
88. The Mineral Production of Canada 1909. Annual Report on—by John McLeish, B.A.
89. Reprint of Presidential address delivered before the American Peat Society at Ottawa, July 25, 1910. By Eugene Haanel, Ph.D.
90. Proceedings of Conference on Explosives.
92. Investigation of the Explosives Industry in the Dominion of Canada, 1910. Report on—by Capt. Arthur Desborough. (Second Edition).
93. Molybdenum Ores of Canada. Report on—by Dr. T. L. Walker.
102. Mineral Production of Canada, 1910. Preliminary Report on—by John McLeish, B.A.
103. Mines Branch Summary Report, 1910.
104. Catalogue of Publications of Mines Branch, from 1902 to 1911; containing Tables of Contents and List of Maps, etc.
110. Western Portion of Torbrook Iron Ore Deposits, Annapolis county, N.S. Bulletin No. 7—by Howells Fréchette, M.Sc.
114. Production of Cement, Lime, Clay Products, Stone, and other Structural Materials in Canada, 1910. Bulletin on—by John McLeish, B.A.
115. Production of Iron and Steel in Canada during the calendar year 1910. Bulletin on—by John McLeish, B.A.
116. Production of Coal and Coke in Canada during the calendar year 1910. Bulletin on—by John McLeish, B.A.
117. General Summary of the Mineral Production in Canada during the calendar year 1910. Bulletin on—by John McLeish, B.A.
143. The Mineral Production of Canada 1910. Annual Report on—by John McLeish, B.A.

IN THE PRESS.

83. An Investigation of the Coals of Canada with reference to their Economic Qualities: as conducted at McGill University under the authority of the Dominion Government. Report on—by J. B. Porter, E.M., D.Sc., and others—
 Vol. III—
 Appendix I
 Coal Washing Tests and Diagrams, by J. B. Porter.
 Vol. IV—
 Appendix II
 Boiler Tests and Diagrams, by R. J. Durley.
 Vol. V—
 Appendix III
 Producer Tests and Diagrams, by R. J. Durley.
100. The Building and Ornamental Stones of Canada. Report on—by Professor W. A. Parks.
111. Diamond Drilling at Point Mamainse, Ont. Bulletin No. 6—by A. C. Lane, Ph.D. with Introductory by A. W. G. Wilson, Ph. D.
118. Mica: Its Occurrence, Exploitation, and Uses. Report on—by Hugh S. de Schmid, M.E.

IN PREPARATION.

83. An investigation of the Coals of Canada with reference to their Economic Qualities: as conducted at McGill University under the authority of the Dominion Government. Report on—by J. B. Porter, E.M., D.Sc., and others—

Vol. VI—

Appendix IV

Coking Tests, by Edgar Stansfield and J. B. Porter.

Appendix V

Chemical Tests, by Edgar Stansfield.

91. Coal and Coal Mining in Nova Scotia. Report on—by J. G. S. Hudson.

MAPS.

6. Magnetometric Survey, Vertical Intensity: Calabogie mine, Bagot township, Renfrew county, Ontario—by E. Nyström, M.E., 1904.
13. Magnetometric Survey of the Belmont Iron Mines, Belmont township, Peterborough county, Ontario—by B. F. Haanel, B.Sc., 1905.
14. Magnetometric Survey of the Wilbur mine, Lavant township, Lanark county, Ontario—by B. F. Haanel, B.Sc., 1905.
15. Magnetometric Survey, Vertical Intensity: Iron Ore Deposits at Austin brook, Bathurst township, Gloucester county, N.B.—by E. Lindeman, M.E., 1906.
33. Magnetometric Survey, Vertical Intensity: Lot 1, Concession VI, Mayo township, Hastings county, Ontario—by Howells Fréchette, M.Sc., 1909.
34. Magnetometric Survey, Vertical Intensity: Lots 2 and 3, Concession VI, Mayo township, Hastings county, Ontario—by Howells Fréchette, M.Sc., 1909.
35. Magnetometric Survey, Vertical Intensity: Lots 10, 11, and 12, Concession IX, and Lots 11 and 12, Concession VIII, Mayo township, Hastings county, Ontario—by Howells Fréchette, M.Sc., 1909.
36. Survey of Mer Bleue Peat Bog, Gloucester township, Carleton county, and Cumberland township, Russell county, Ontario—by Erik Nyström, M.E., and A. Anrep, Peat Expert.
37. Survey of Alfred Peat Bog, Alfred and Caledonia townships, Prescott county, Ontario—by Erik Nyström, and A. Anrep, Peat Expert.
38. Survey of Welland Peat Bog, Wainfleet and Humberstone townships, Welland county, Ontario—by Erik Nyström, M.E., and A. Anrep, Peat Expert.
39. Survey of Newington Peat Bog, Osnabrook, Roxborough, and Cornwall townships, Stormont county, Ontario—by Erik Nyström, M.E., and A. Anrep, Peat Expert.
40. Survey of Perth Peat Bog, Drummond township, Lanark county, Ontario—by Erik Nyström, M.E., and A. Anrep, Peat Expert.
41. Survey of Victoria Road Peat Bog, Bexley and Carden townships, Victoria county, Ontario—by Erik Nyström, M.E., and A. Anrep, Peat Expert.
48. Magnetometric Map of Iron Crown claim at Klaanch river, Vancouver island, B.C.—by Einar Lindeman, M.E.
49. Magnetometric Map of Western Steel Iron claim, at Sechart, Vancouver island, B.C.—by Einar Lindeman, M.E.
50. Vancouver island, B.C.—by Einar Lindeman, M.E.
51. Iron Mines, Texada island, B.C.—by E. H. Shepherd, C.E.
52. Sketch Map of Bog Iron Ore Deposits, West Arm, Quatsino sound, Vancouver island, B.C.—by L. Frank.
53. Iron Ore Occurrences, Ottawa and Pontiac counties, Quebec, 1908—by J. White, and Fritz Cirkel, M.E.
54. Iron Ore Occurrences, Argenteuil county, Quebec, 1908—by Fritz Cirkel, M.E.
57. The Productive Chrome Iron Ore District of Quebec—by Fritz Cirkel, M.E.
60. Magnetometric Survey of the Bristol mine, Pontiac county, Quebec—by Einar Lindeman, M.E.
61. Topographical Map of Bristol mine, Pontiac county, Quebec—by Einar Lindeman, M.E.
64. Index Map of Nova Scotia: Gypsum—by W. F. Jennison, M.E.
65. Index Map of New Brunswick: Gypsum—by W. F. Jennison, M.E.

66. Map of Magdalen islands: Gypsum—by W F. Jennison, M.E.
70. Magnetometric Survey of Northwest Arm Iron Range, Lake Timagami, Nipissing district, Ontario—by Einar Lindeman, M.E.
72. Brunner Peat Bog, Ontario—by A. Anrep, Peat Expert.
73. Komoka Peat Bog, Ontario—by A. Anrep, Peat Expert.
74. Brockville Peat Bog, Ontario—by A. Anrep, Peat Expert.
75. Rondeau Peat Bog, Ontario—by A. Anrep, Peat Expert.
76. Alfred Peat Bog, Ontario—by A. Anrep, Peat Expert.
77. Alfred Peat Bog, Ontario: Main Ditch profile—by A. Anrep, Peat Expert.
78. Map of Asbestos Region, Province of Quebec, 1910—by Fritz Cirkel, M.E.
86. Map showing general distribution of Serpentine in the Eastern Townships—by Fritz Cirkel, M.E.
94. Map showing Cobalt, Gowganda, Shiningtree, and Porcupine districts—by L. H. Cole, B.Sc.
95. General Map of Canada showing Coal Fields. (Accompanying report No. 83—by Dr. J. B. Porter).
96. General Map of Coal Fields of Nova Scotia and New Brunswick. (Accompanying Report No. 83—by Dr. J. B. Porter).
97. General Map showing Coal Fields in Alberta, Saskatchewan, and Manitoba. (Accompanying Report No. 83.—by Dr. J. B. Porter).
98. General Map of Coal Fields in British Columbia. (Accompanying Report No. 83—by Dr. J. B. Porter).
99. General Map of Coal Field in Yukon Territory. (Accompanying Report No. 83—by Dr. J. B. Porter).
106. Austin Brook Iron Bearing district, Bathurst township, Gloucester county, N.B.—by E. Lindeman, M.E.
107. Magnetometric Survey, Vertical Intensity: Austin Brook Iron Bearing district—by E. Lindeman, M.E.
108. Index Map showing Iron Bearing Area at Austin Brook—by E. Lindeman, M.E.
109. Sections of Diamond Drill Holes in Iron Ore Deposits at Austin Brook—by E. Lindeman M.E.
141. Torbrook Iron Bearing District, Annapolis county, N.S.—by Howells Fr chette, M.Sc.

IN THE PRESS.

112. Sketch plan showing Geology of Point Mamainse, Ont.—by Professor A. C. Lane.
- 119–137. Mica: Townships maps, Ontario and Quebec—by Hugh S. de Schmid, M.E.
138. Mica: Showing location of Principal Mines and Occurrences in the Quebec Mica Area—by Hugh S. de Schmid.
139. Mica: Showing Location of Principal Mines and Occurrences in the Ontario Mica Area—by Hugh S. de Schmid.
140. Mica: Showing Distribution of the Principal Mica Occurrences in the Dominion of Canada—by Hugh S. de Schmid.

IN PREPARATION.

113. Holland Peat Bog, Ontario—by A. Anrep, Peat Expert.
146. Distribution of Iron Ore Sands of the Iron Ore Deposits on the North Shore of the River and Gulf of St. Lawrence, Canada—by Geo. C. Mackenzie, B.Sc.
152. Map showing the location of peat bogs investigated in Ontario—by A. Anrep, Jr.
153. Map Showing the location of peat bogs investigated in Manitoba—by A. Anrep, Jr.