



**GEOLOGICAL SURVEY OF CANADA  
OPEN FILE 6275**

**2008 Louis S. St-Laurent  
Field Report  
August 22 – October 3, 2008**

**H.R. Jackson and K.J. DesRoches, Editors**

**2010**



Natural Resources  
Canada

Ressources naturelles  
Canada

**Canada**



**GEOLOGICAL SURVEY OF CANADA  
OPEN FILE 6275**

**2008 Louis S. St-Laurent Field Report  
August 22 – October 3, 2008**

**H.R. Jackson and K.J. DesRoches, Editors**

**2010**

©Her Majesty the Queen in Right of Canada 2010

This publication is available from the Geological Survey of Canada Bookstore  
([http://gsc.nrcan.gc.ca/bookstore\\_e.php](http://gsc.nrcan.gc.ca/bookstore_e.php)).

It can also be downloaded free of charge from GeoPub (<http://geopub.nrcan.gc.ca/>).

Jackson, H.R. and DesRoches, K.J. 2010. 2008 Louis S. St-Laurent Field Report, August 22 – October 3, 2008, Geological Survey of Canada, Open File 6275, 184 p.

Table of Contents

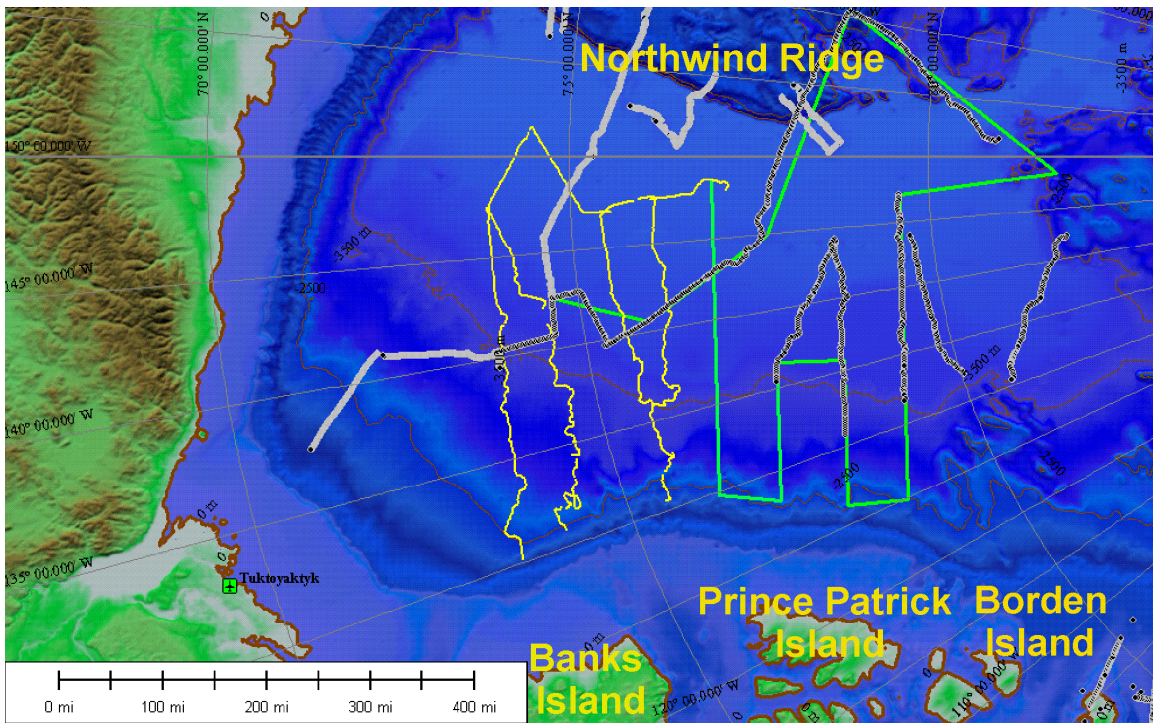
Executive Summary .....	1
1 Ship and Scientific Crew .....	4
1.1 Personnel.....	4
1.2 Brief Biographies of the Scientific Staff .....	22
1.2.1 Jon Biggar .....	22
1.2.2 Kelley Brumley .....	22
1.2.3 Borden Chapman, CET .....	22
1.2.4 Jim Etter .....	23
1.2.5 Paul Girouard.....	23
1.2.6 Deborah Hutchinson Gove .....	24
1.2.7 Ruth Jackson.....	24
1.2.8 Donald Kalley.....	25
1.2.9 Fred Learning.....	25
1.2.10 Jonah Nakimayak.....	26
1.2.11 Shigeto Nishino.....	26
1.2.12 Fredrick John Oliff .....	26
1.2.13 Rodger Oulton .....	27
1.2.14 Ryan Douglas Pyke.....	27
1.2.15 Dwight Reimer.....	27
1.2.16 Dale Ruben.....	28
1.2.17 John Ruben .....	28
1.2.18 Nelson Ruben .....	28
1.2.19 John Shimeld.....	29
1.2.20 Peter Vass.....	29
2 Diary of the Chief Scientist .....	31
3 Weekly Messages .....	77
3.1 Sunday August 24, 2008.....	77
3.2 Sunday August 31, 2008.....	78
3.3 Sunday September 7, 2008.....	78
3.4 Sunday September 14, 2008 .....	80
3.5 Sunday September 20, 2008 .....	82
4 Technical Report on Bathymetry Acquisition.....	85
4.1 Introduction .....	85
4.2 Summary.....	85
4.3 Sounding Methods.....	85
4.4 Positioning Methods .....	87
4.5 Data Collection .....	87
4.6 Data Processing.....	89
4.7 Recommendations and Conclusions .....	89
4.8 Acknowledgements .....	90
5 Technical Report on the Seismic System.....	92
5.1 Introduction .....	93
5.2 Historical Background.....	93
5.3 Equipment .....	93
5.3.1 The Tow Sled System.....	94
5.3.2 Compressor and air distribution system.....	103
5.3.3 GeoEel Digital Seismic Streamer and Deck Handling System .....	111
5.3.4 Sonobuoy System.....	115
5.3.5 Data Distribution about the vessel .....	118
5.3.6 Recommendations for future technical work: .....	122
5.3.7 Technical Appendices .....	125
6 Acquisition and Processing of the Seismic Reflection Data.....	135

6.1	Introduction .....	135
6.2	Source Parameters.....	138
6.2.1	Source Array.....	138
6.2.2	Shot Interval.....	139
6.2.3	Calibrated Measurements of the Seismic Source .....	139
6.3	Receiver Parameters .....	143
6.4	Source/Receiver Offsets.....	143
6.5	Recording Parameters .....	143
6.6	Noise Records.....	146
6.7	Data Storage.....	152
6.8	Data Quality Monitoring and Seismic Watchkeeping.....	152
6.9	Data Processing .....	154
6.9.1	Processing steps.....	154
6.9.2	Estimation of Streamer Depths.....	156
6.10	Recommendations .....	159
7	Marine Mammal Monitoring Report.....	160
8	Overview of Ice Conditions .....	162
9	XCTD Report .....	175
9.1	Objective .....	175
9.2	Method .....	175
9.3	Preliminary Results .....	177
9.4	Data Management Policy.....	180

# Executive Summary

H. Ruth Jackson

In 2008's summer field season, the Geological Survey of Canada (GSC) and the United States Geological Survey (USGS) undertook a joint operation in the Canada Basin from the Canadian polar margin (Figure 1) to the Northwind Ridge. The purpose of the expedition was to acquire geophysical data that could be used by Canada and the United States in determining the boundaries of their respective extended continental shelves in the Beaufort Sea, using the definition provided in Article 76 of the United Nations Convention on the Law of the Sea (UNCLOS). Historically, ice conditions have created difficult conditions for collecting underway geophysical information in the Beaufort Sea, so a two ship survey enabled data collection in areas previously inaccessible. During the expedition, which ran from August 21, 2008 to October 2, 2008, the CCGS Louis S. St-Laurent (LSSL) collected 2817 km of seismic reflection profiles and 4849 km of single beam bathymetric soundings. For its part of the expedition, during the period of September 10 to 27 the USCGC Healy (Healy) accompanied the LSSL and contributed multibeam bathymetric data and high resolution chirp subbottom profiler data. For much of the period when both ships worked together, the Healy broke ice for the LSSL to facilitate seismic operations, and in areas where high quality multibeam sonar data was desired, the Louis broke for the Healy.



**Figure 1** The continuous black dots represent the location of the 2008 seismic reflection profiles. The green lines show the planned track. The yellow lines indicate the seismic reflection profiles collected in 2007. The grey lines are location of profiles collected in 1993 by the United States Geological Survey.

To collect seismic reflection data in ice covered waters, specially-designed over-the-side seismic equipment was used. The main components of the seismic reflection

system were the compressor, the sound source (air gun array), receiver array (hydrophone array) and the electronic system for recording and displaying the data. The unique nature of the vessel used and the environmental conditions required a unique source and receiver system. The Louis S. St. Laurent is not a purpose-built seismic vessel, rather it is a heavy-duty ice breaker and as such, it does not have as large a working deck as might be desired for standard industry seismic equipment. In addition, the in-water seismic elements would have to be able to withstand contact with heavy ice during regular operation. To meet both of these requirements, a small working deck and heavy ice, a heavy tow sled was designed from which the source array was suspended and the receiver array was towed. The 2008 expedition was the third season the system was used. Building on the experience of previous years, this year the two large (520 in<sup>3</sup>) air guns were separated by spreader bars so they did not smash into each other and making it possible to suspend a third gun from the sled. The third gun, a 150 in<sup>3</sup> airgun, was added to provide higher frequencies and improve the resolution of the seismic data. A total of 85,664 sound pulses were created during the expedition and overall the equipment functioned well. It is a credit to those who designed, built and maintained it.

The location of the ice varies from year to year. Although there was more ice than last year, the first three lines this year were run in an area that had significant ice cover last year but was open water this year. The National Snow and Ice Data Center in Boulder Colorado reported that the coverage of the Arctic Ocean ice pack was 33% below average since monitoring began in 1979. The ice extent at its minimum was at 1.74 million sq miles compared to 1.59 million sq miles last year. Overall, along the first seven lines that ran along the centre of the Canada Basin, across the northern edge of the Northwind Rise to the southern reaches of the Alpha Ridge at 82°N, the ice conditions were easily passable with a single ice breaker. No ice in compression was encountered. To the east the conditions changed, a significant portion of the ice was multiyear several meters thick and the ice was under moderate to medium pressure. In addition, as the days shortened in September new ice was forming initially as nilas then through the grey-white to white ice stage. The formation of nilas (new ice) took place 3 weeks earlier in 2008 than in 2007.

In order to deal successfully with the expected thick and under pressure ice in the eastern Canada Basin, two ice breakers were required. The challenges associated with collecting seismic reflection profiles with two ice breaker are many. Breaking ice is normally accomplished at speeds greater than 10 knots. The airgun array and streamer cannot be towed at greater than 4 knots. Maintaining a proper distance between the icebreakers is a judgment call dependent on ice conditions. The lead ice breaker is more vulnerable to being stopped by pressure ridges and Healy had to back and ram. Ice under pressure will close the path behind the lead ice breaker in few minutes. If the second ship LSSL is too close and has to stop while the lead ice breaker Healy is backing and ramming the ice will adhere to its hull requiring high power on the engines to break free that will send a significant flow of water past the air guns and streamer putting them at extreme risk for damage and loss. The propulsion can lift the towed array out of the water. Hence, the two ships must carefully coordinate their efforts and make adjustments accordingly. Occasionally, the lead ice breaker must be called back to free the towing breaker, this takes about an hour and a half. If additional power from the LSSL engines are required this could be done in twenty minutes though the seismic gear is at risk. This later option requires consultation with the technical staff monitoring the equipment. In the northeast section of our survey on two occasions both ice breakers side-by-side were

required backing in ramming in sequence to reach the 2500 m contour. It is a credit to both ice breakers how this interplay was managed. A measure of the success of the various strategies was no equipment was lost.

The quality of the seismic reflection profiles exceeded expectations. The onboard seismic reflection processing benefited from the experience of last year so that the processing sequence could be used and embellished. A significant advance over the previous year was the calibration of the airgun signal so that deconvolution could be done more accurately. It was also learned that the streamer depth was not constant along the array and this variation could be determined from the first water bottom pulse allowing for improved static corrections. These steps made a visible difference in the processed records. Brute stack, deconvolutions and migrated section were available at sea thanks to the tireless efforts of John Shimeld.

The high quality seismic reflection profiles available were interpreted. They indicated several areas with different character of both the sedimentary section and basement. Within about 300 km of the Northwind escarpment the sedimentary section is dominated by up to 3 seconds of highly stratified sedimentary section that overlies a basement that deepens consistently towards the gravity low previously identified as a spreading centre by other researchers. In the proximity of the Canadian margin offshore of Banks Island, the sedimentary section is more disrupted and the basement has a more irregular topography and occurs at greater travel times. On the Canadian margin off of Prince Patrick and Borden islands, the sedimentary section is thinner and the basement shallows towards the polar margin. On the bathymetric rise off of Borden Island the basement character shows seaward dipping reflectors similar to those observed on the Alpha Ridge.

Wide angle reflection and refractions from the 39 sonobuoys launched will enable the time on the vertical incident reflection profiles to be converted to depths to meet the requirements of Article 76 and to provide additional information on the nature of the basement. Of the 39 sonobuoys: 4 failed completely, 2 recorded for less than 1 hour, 8 recorded for the full 8 hours before scuttling, and the rest had ranges of 2-6 hours.

Before the expedition it was not clear if having a lead ice breaker would improve the quality of the multibeam data. The effectiveness of having a lead ice breaker was demonstrated as soon as we were in the Canadian ice pack. The Healy had continued as the lead after the seismic gear was brought on board. The data quality was poor. After the ships changed positions, much improved usable data were acquired. A total of 2300 km of good quality multibeam soundings were recorded.

The 5500 km of single beam bathymetry was collected from LSSL supported by 63 XCTD and 5 SVP. In addition 181 spot soundings were acquired. Bathymetric data are needed to determine the Foot of the Slope (FoS) for the claim for the extended continental shelf. The bathymetry will also be used to update Canadian hydrographic charts.

Marine mammal monitoring took place 24 hours a day during the entire expedition by experienced observers from Paulatuk, N.W.T. Only a few mammals (seals and polar bears) were seen during the entire expedition. Only three sightings required shutting down the airgun array for up to 20 minutes. During the last few days of the trip up to a dozen snowy owls either roosted on the ship or flew along with it.

# 1 Ship and Scientific Crew

## 1.1 Personnel

Table 1.1.1 Crew of the Louis S. St. Laurent

Position	Name
<b>Commanding Officer</b>	<b>Marc Rothwell</b>
<b>Chief Officer</b>	<b>Roy Lockyer</b>
<b>First Officer</b>	<b>Stephane Lequalt</b>
<b>Second Officer</b>	<b>Catherine Lacombe</b>
<b>Third Officer</b>	<b>Neil Turnbull</b>
<b>Chief Engineer</b>	<b>Mark Cusack</b>
<b>Senior Engineer</b>	<b>Dave Baur</b>
<b>First Engineer</b>	<b>Matther Klebert</b>
<b>Second Engineer</b>	<b>Freeman Stevens</b>
<b>Third Engineer</b>	<b>Jan Yip</b>
<b>Electrical Officer</b>	<b>Phillip Seaboyer</b>
<b>Logistic Officer</b>	<b>Rod Johnston</b>
<b>Electrician</b>	<b>Todd Smith</b>
<b>Boatswain</b>	<b>Robert Taylor</b>
<b>Carpenter</b>	<b>Eugene Jones</b>
<b>Winchman</b>	<b>Peter King</b>
<b>Leading Seaman</b>	<b>Dale Hiltz</b>
<b>Leading Seaman</b>	<b>Stanley Fleet</b>
<b>Seaman</b>	<b>Neil Jollymore</b>
<b>Seaman</b>	<b>Bill May</b>
<b>Seaman</b>	<b>Kelly Hansen</b>
<b>Seaman</b>	<b>David Sisco</b>



Seaman	Andre Poirier
Seaman	Jean Marc Cormier
Seaman	Daniel B. Maclean
E/R Technician	Sherry Hudson
E/R Technician	David Scott Curry
E/R Technician	James Richardson
E/R Mechanic	Edward Ginter
E/R Mechanic	Miles Taker
E/R Mechanic	Phil MacPherson
E/R Mechanic	Greg Fielding
E/R Mechanic	Timothy Beaton
E/R Mechanic	Leonard Brown
Chief Cook	Paul Devlin
Storekeeper	John Metcalf
Storekeeper	Andrew Demerchant
Second Cook	Mark Lewis
Second Cook	John Ashley Merrick
Second Cook	Keith Kingston
Steward	Donna Kennedy
Steward	Michael W. Goodwin
Steward	Brenda Kennedy
Steward	Christopher Marshall
Steward	Alfred Haines
Helicopter Pilot	Jim Myra
Helicopter Engineer	Stephen Lloyd
Electronics Tech	Lorne Anderson

**Table 1.1 (continued)**

<b>Ice Observer</b>	<b>Barbara Molyneaux</b>
<b>Medical Officer</b>	<b>Margaret Lamontagne</b>
<b>Officer Cadet</b>	<b>Keelen Black</b>
<b>Officer Cadet</b>	<b>Bennet Light</b>
<b>Officer Cadet</b>	<b>Mariah McCooey</b>
<b>Officer Cadet</b>	<b>Amy Tuck</b>

**Table 1.1.2 Scientific Staff**

<b>Name</b>	<b>Position</b>
<b>Jon Biggar</b>	<b>Chief Hydrographer</b>
<b>Kelley Brumley</b>	<b>Student – University of Alaska</b>
<b>Borden Chapman</b>	<b>Chief Technical Support</b>
<b>Jim Etter</b>	<b>Hydraulics Technician</b>
<b>Paul Girouard</b>	<b>Navigation</b>
<b>Deborah Hutchinson</b>	<b>USGS Representative</b>
<b>Ruth Jackson</b>	<b>Chief Scientist</b>
<b>Donald Kelley</b>	<b>Hydrographer</b>
<b>Fred Learning</b>	<b>Compressor Technician</b>
<b>Fred Oliff</b>	<b>Hydrographer</b>
<b>Jonah Nakimayak</b>	<b>Marine Mammal Monitor</b>
<b>Shigeto Nishono</b>	<b>Oceanographer</b>
<b>Rodger Oulton</b>	<b>Compressor Technician</b>
<b>Ryan Pike</b>	<b>Airgun Technician</b>
<b>Dwight Reimer</b>	<b>Technical Support – Streamer</b>
<b>Dale Ruben</b>	<b>Marine Mammal Monitor</b>
<b>John O. Ruben</b>	<b>Marine Mammal Monitor</b>

**Nelson Ruben**

**Chief Monitor / Airgun  
Technician**

**John Shimeld**

**Data Processing**

**Peter Vass**

**Welding, Compressor Technician**



**Marc Rothwell**  
Commanding Officer



**Roy Lockyer**  
Chief Officer



**Stephane Legault**  
First Officer



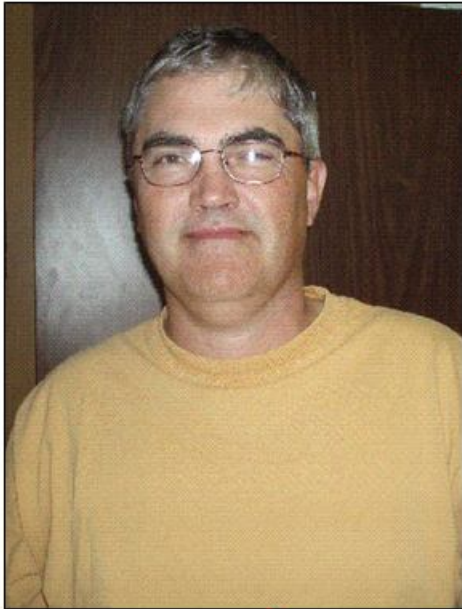
**Catherine Lacombe**  
2<sup>nd</sup> Officer



**Neil Turnbull**  
3<sup>rd</sup> Officer



**Figure 1.1** Crew of the Louis S. St. Laurent (and a bear).



**Rod Johnston**  
Logistics Officer



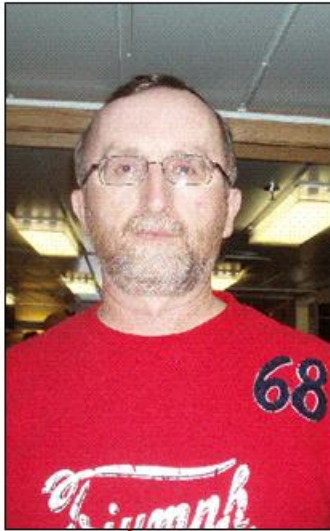
**Margaret Lamontagne**  
Medical Officer



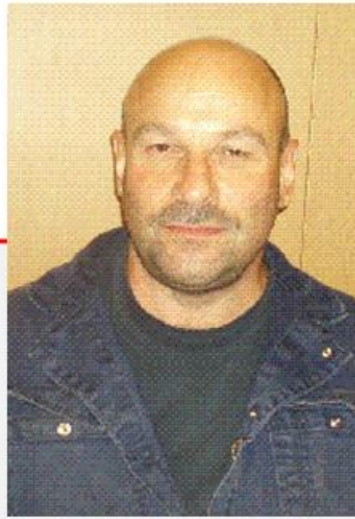
**Barbara Molyneaux**  
Ice Observer



Figure 1.2 Crew of the Louis S. St. Laurent (cont'd).



**Mark Cusack**  
Chief Engineer



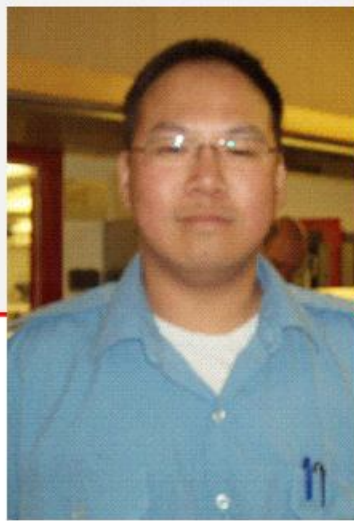
**Dave Baur**  
Senior Engineer



**Matthew Klebert**  
1<sup>st</sup> Engineer



**Freeman Stevens**  
2<sup>nd</sup> Engineer



**Jan Yip**  
3<sup>rd</sup> Engineer



Figure 1.3 Crew of the Louis S. St. Laurent (cont'd).



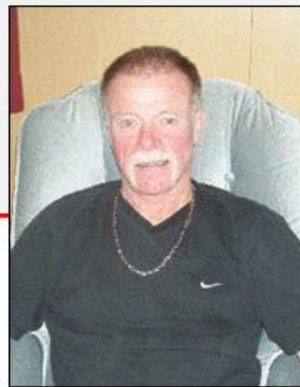
**Dale Hiltz**  
Leading Seaman



**Stanley Fleet**  
Leading Seaman



**Daniel Maclean**  
Seaman



**Bill May**  
Seaman



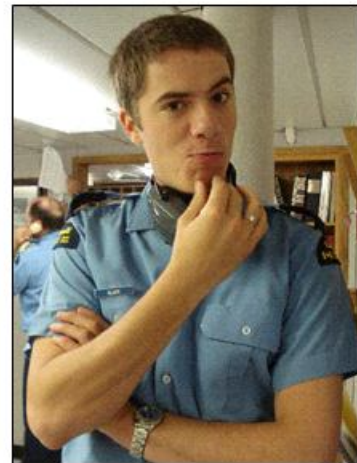
**Neil Jollymore**  
Seaman



Figure 1.4 Crew of the Louis S. St. Laurent (cont'd).



**Bennet Light**  
Officer Cadet



**Keelan Black**  
Officer Cadet

**Mariah McCooey**  
Officer Cadet



**Amy Tuck**  
Officer Cadet

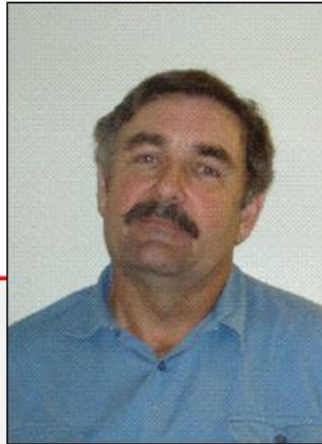


Figure 1.5 Crew of the Louis S. St. Laurent (cont'd).





**Jamie Richardson**  
E/R Technician



**Phillip Seaboyer**  
Electrical Officer



**Scott Curry**  
E/R Technician

**Todd Smith**  
Electrician



**Sherry Hudson**  
E/R Technician

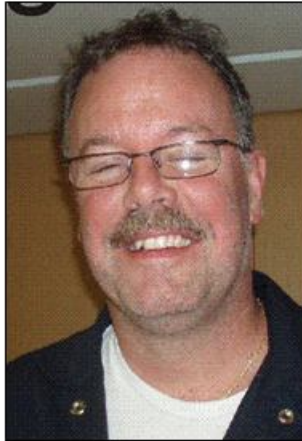


**Lorne Anderson**  
Electronics Technician

Figure 1.6 Crew of the Louis S. St. Laurent (cont'd).



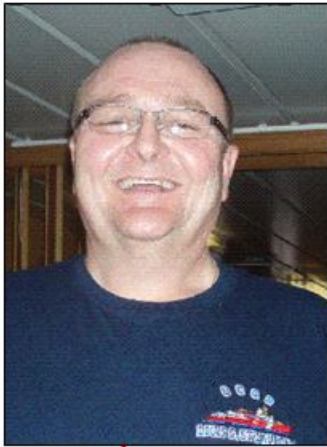
**Leonard Brown**  
E/R Mechanic



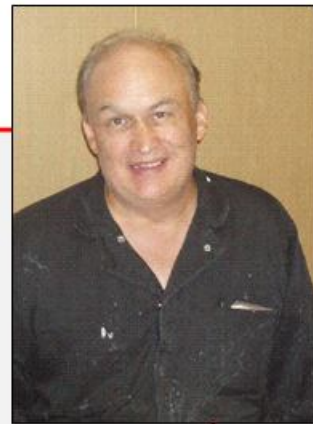
**Greg Fielding**  
E/R Mechanic



**Timothy Beaton**  
E/R Mechanic



**Miles Taker**  
E/R Mechanic



**Ed Ginter**  
E/R Mechanic



**Phil MacPherson**  
E/R Mechanic

Figure 1.7 Crew of the Louis. S. St. Laurent (cont'd).



**Donna Kennedy**  
Steward



**Alfred Haines**  
Steward



**Brenda Kennedy**  
Steward



**Michael Goodwin**  
Steward



**Christopher Marshall**  
Steward



**Jay Demerchant**  
Storekeeper

**Jack Metcalf**  
Storekeeper

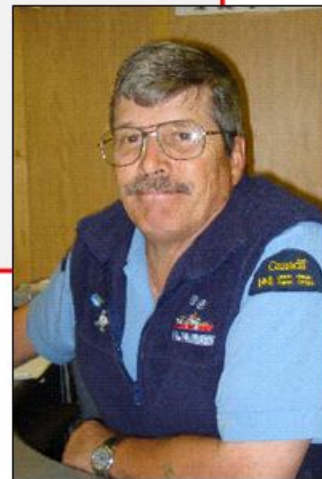
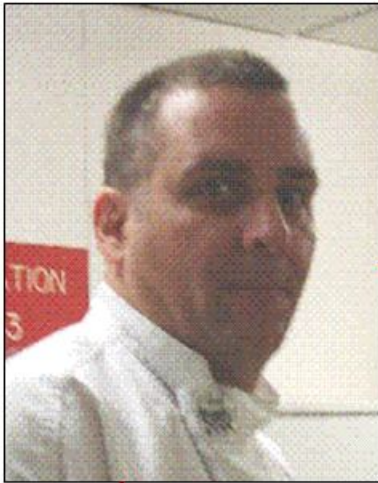


Figure 1.8 Crew of the Louis S. St. Laurent (cont'd).



**Paul Devlin**  
Chief Cook



**Keith "Scooter"  
Kingston**  
2<sup>nd</sup> Cook



**Mark Lewis**  
2<sup>nd</sup> Cook

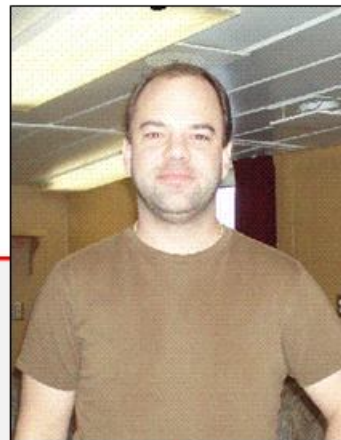


**John Merrick**  
2<sup>nd</sup> Cook

Figure 1.9 Crew of the Louis S. St. Laurent (cont'd).



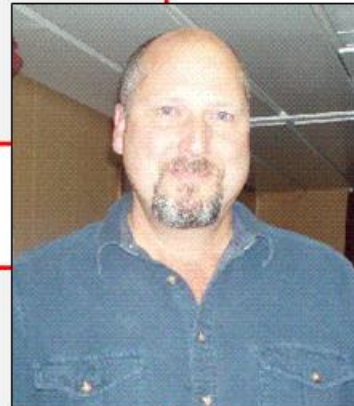
**Bob Taylor**  
Boatswain



**Jim Myra**  
Helicopter Pilot



**Eugene Jones**  
Carpenter



**Steven Lloyd**  
Helicopter Engineer

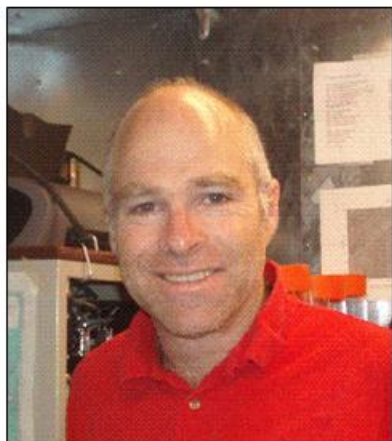


**Peter King**  
Winchman

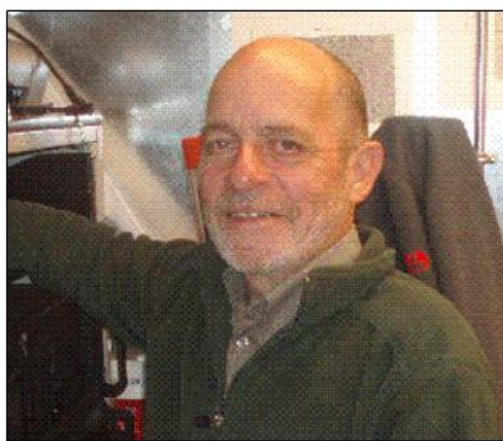


Figure 1.10 Crew of the Louis S. St. Laurent (cont'd).

# Science Staff



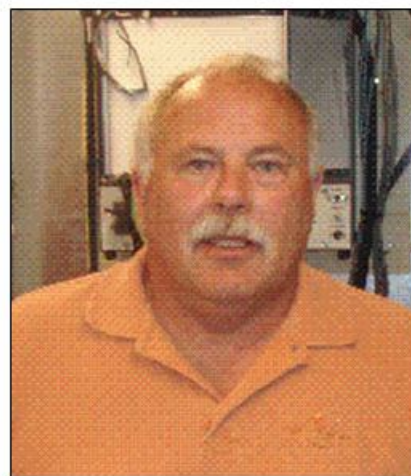
**Fred Oliff**



**Paul Girouard**



**Dwight Reimer**



**John Biggar**



**Figure 1.21 Science staff.**



**Donald Kalley**



**Rubin Nelson**

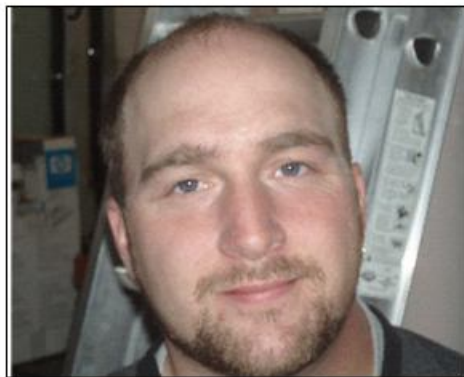


**Jim Etter**



**Fred Learning**

**Science Staff**



**Ryan Pike**



**Jonah Nakimak**

**Figure 1.12 Science staff (cont'd).**



**Peter Vass**

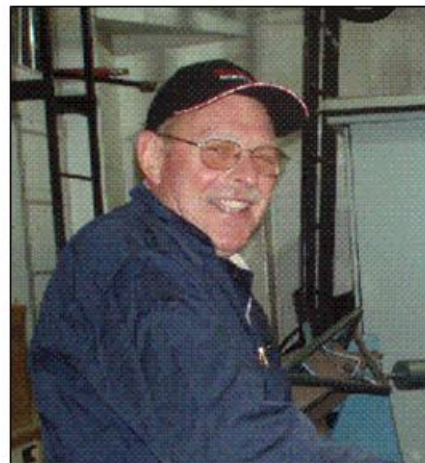


**John Shimeld**

# Science Staff



**Dale Ruben**



**Roger  
Oulton**



**John O Ruben**

**Figure 1.13 Science staff (cont'd).**





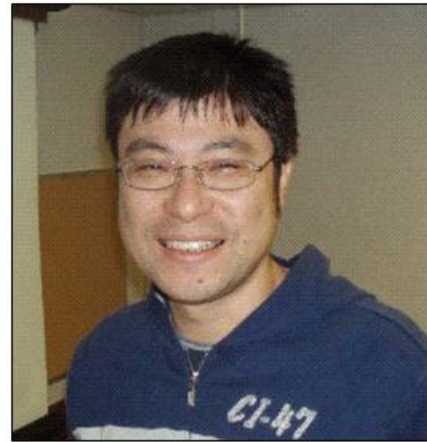
**Ruth Jackson**



**Debbie Hutchnison-Gove**



**Borden Chapman**



**Shigeto Nishino**



**Kelley Brumley**

**Figure 1.14 Science staff (cont'd).**

## **1.2 Brief Biographies of the Scientific Staff**

### **1.2.1 Jon Biggar**

Jon has over 30 years of experience with the Canadian Hydrographic Service, Central and Arctic Region. He is a college graduate of commercial diving and Civil/Marine Technology from Seneca College. Jon received his Canada Land Surveyor Commission (CLS) in 1987. His current responsibility with the UNCLOS portfolio includes extensive periods on ice camps in the High Arctic winters, as well as enjoying the fine camaraderie of the fine folks on the *Louis*. Jon has surveyed in almost every body of water in the Central & Arctic Region area of responsibility.

When not out collecting Inuit art for his extensive collection, Jon lives with his wife Norma in a house built largely of his own hands in Carlisle, Ontario. His dog, Melah, named after Brian Mulroney's wife, is tasked with keeping the blue herons from stealing fish from his pond.

Norma and Jon like candlelit dinners, moonlit walks on warm tropical sand beaches and the occasional glass or two of fine red wine.

### **1.2.2 Kelley Brumley**

Before going back to school to study geology, Kelley had almost completed a Fine Art degree and was making a decent living as an artist in Illinois. Prior to that she was in television advertising in Oregon and Texas, a layout artist, a free lance window designer in San Francisco, and even did a 4 year stint in the US Air Force as a Linguist during the Contra/Sandinista bru-ha-ha.

After her first class in geology, however, she knew she had found the thing. That Thing that stimulates one's imagination, changes one's world view, and creates a passion that makes one work long hours not noticing the time usage. After completing her undergraduate studies at Southern Oregon University, she decided to continue for a Masters degree at University of Alaska Fairbanks because a guy named Bernard Coakley, called her up and said "hey, how would you like to spend summers on ice breakers in the Arctic Ocean and figure out how it became an Ocean?"

To have the opportunity to go where few have gone before is exactly why people go through the rigors of a scientific education. So she accepted and moved to Fairbanks, Alaska, enduring a winter there with no indoor plumbing. The following year her adviser went on sabbatical so the lead scientist of her first arctic cruise aboard the Healy in 2006 (Larry Lawver) invited me to come to the University of Texas, Austin where she has been a visiting scientist for the past 9 months. She plans to continue for a PhD at Stanford and figure out what the rocks dredged this summer are, and what they mean to the tectonic evolution of the Arctic Ocean.

### **1.2.3 Borden Chapman, CET**

Borden was born in Montreal PQ and educated through the grade school system in Amherst, NS. He completed 2 years of pre-engineering at Mount Alison University,

Sackville NB before graduating with a Diploma of Electronic Engineering Technology, NSCC Halifax. He was employed by Energy, Mines and Resources as Electronic Technologist for a 1 year term following graduation and accepted a position with DFO as Senior Electrical Officer on board CSS Hudson for 3 years. He returned to energy, Mines and Resources (now NRCan) for a second 1 year term as an Electronics Design Technologist.

After accepting a position with Eastern provincial Airways as a Flight Simulator Maintenance Tech on Eastern Provincial Airway's Boeing 737 flight simulator, attending flight ground school and logging 130 hrs of flight experience on the 737B jet simulator, Borden returned to NRCan and accepted a full time position as Electronics Design Technologist working on various projects including NRCan's Ocean Bottom Seismometer program, the bottom "lander" called Ralph, numerous data logging systems for underwater devices and systems including still and video camera systems, seismic timing and control electronics, Side Scan Sonar systems, gravity and magnetics systems.

He assumed responsibility for all seagoing mechanical equipment for the Geological Survey of Canada (Atlantic) including HP air compressors, air guns and arrays, control systems and field logistics associated with them. He is responsible for logistical operations for Canada's UNCLOS program on board the CCGS Louis S. St. Laurent, including liaison with DFO and CCG staff and directly with ship's personnel in areas related to program and ship matters. He manages the day to day activities of the technical team contracted to carry out the UNCLOS marine research program both on shore and at sea.

#### **1.2.4 Jim Etter**

Jim is from Shubenacadie, Nova Scotia and has lived in the Fall River area for the past 32 years. He has been married for 32 years and has two children, Carolyn and Jamison. After working at the Bedford Institute of Oceanography for 30 years as an electrical technician in the computer/microwave shop, he retired in 1999 and took a part-time position at the Consolidated Fluid Power building designing training aids for the school to make students' life tough learning hydraulics. Later, he was employed part-time at Strictly Hydraulics and Design building power units for customers' needs, servicing engine room controls and equipment on various ships. After nine years he returned to sea at the request of Borden Chapman, specifically for the UNCLOS program.

His hobbies are wood working and restoring antique cars to their days of glory. This includes every aspect from mechanical repairs to body work to painting. One of the enjoyable moments was working with his son (then twelve years old) dismantling and reassembling a 58 Ford Fairlane 500 that they still maintain. The highlight of this was at a wedding two years ago when he was asked to drive the bride and groom away from the reception in the car.

#### **1.2.5 Paul Girouard**

Paul was employed by National Resources Canada at BIO for 35 years, retiring in February of 2007. Ashore, he held a variety of scientific support positions and for the last 20 years was responsible for network infrastructure and IT in general. At sea, he

was responsible for scientific navigation, IT and networking, as well as data distribution and archiving. He presently works under contract with Geoforce Consultants Ltd.

### **1.2.6 Deborah Hutchinson Gove**

Debbie Hutchinson grew up as a member of a global society, living in unusual places such as Bombay, India (preschool), Connecticut (elementary school), London, England (middle school), Hamburg, Germany (high school) and Troy, New York (high school). Unlike many members of today's mobile younger generation, she had the good fortune of now staying put and working for the same organization, the U.S. Geological Survey, for her entire research career. She was hired as an entry level Geologic Field Assistant, worked her way through two advanced degrees, and then climbed the USGS career ladder. As a new college graduate, one of her first duties at USGS was to move the then Branch Chief from temporary rented office space in the village to a new USGS science building on the recently opened Quissett campus of the Woods Hole Oceanographic Institution. Just over 20 years later she moved into that same office as Center Director of a much larger, multidisciplinary workforce. Her geology education began with mapping exercises in cow pastures in Vermont (B.A., Middlebury College), took a brief detour into an urban, lacustrine, and pre-Mesozoic setting (M.Sc., University of Toronto), then focused on geological oceanography (Ph.D., University of Rhode Island) and has continued with the life-long learning that is part of doing research in an international scientific community (Woods Hole). Most of her research has sought to understand the origin and evolution of the Atlantic passive continental margin and continental rifts in general; many ancillary interests developed along the way—gas hydrates, Quaternary history of large inland lakes, and crustal structure of the Precambrian shield around the Great Lakes. After rotating out of Center Director position, she now leads two projects: USGS Gas Hydrates and USGS Law of the Sea studies. None of these accomplishments would have been possible without the generous and unflagging support of her wonderful family – husband Lee, son Matt, and daughter Abby, who put up with erratic schedules, long absences, and the lack of common sense that they say characterizes most PhD's!

### **1.2.7 Ruth Jackson**

Ruth was born in Halifax and attended school there. She attended Dalhousie University and received an undergraduate degree in geology in 1972. She started her sea going career in St Margaret's Bay on a fishing boat called "Whip the Wind" collecting high resolution seismic profiles and geological sampling. She was hired by the Geological Survey of Canada (GSC) and spent up to two months a year on the CSS Hudson on the east coast working as far north as Baffin Bay. After 5 years she continued her education at the University of Durham in England where she was awarded a Masters Degree in Geophysics. On returning to the GSC she participated in a series of field projects in the Arctic Ocean based on the ice studying the crustal structure. She attended university for the third time in Norway at the University of Oslo where Ruth was given a D.Sc. After returning she was busily engaged in ship based work often investigating the continent-ocean transition. She has also had opportunities to sail on the Germany research vessel Polarstern and the USCGC Polar Star. These activities prepared her for the task of collecting and interpreting data in

the Arctic relevant for Canada's signing the treaty called the United Nations Convention on the Law of the Sea.

As an antidote for her sea time, Ruth and her husband John participate in outdoor activities including hiking, cycling and kayaking. Our favourite vacations involve cycling in distant lands in March and April when the weather refuses to cooperate in Nova Scotia.

### **1.2.8 Donald Kalley**

Donald was born in Freetown, Sierra Leone, West Africa to Sylvester (deceased) and Patricia (alive and strong). He graduated with an honours degree in civil engineering from Fourah Bay College, University of Sierra Leone in July of 1995. He has worked on several civil engineering projects including the Rogbere-Pamalap highway project linking Sierra Leone and Guinea, the Freetown Road Infrastructure Project, underground water seepage studies at the Kingtom power station, structural design of reinforced concrete elements including slabs, beams, columns, foundations and retaining walls. In addition, he has undertaken numerous architectural designs for residential buildings using AutoCAD and Autodesk architectural desktop software.

The brutal civil war which started in 1991, forced him to seek refuge in Banjul, The Gambia, West Africa. There he spent 7 years in Banjul as a refugee; some in a refugee camp under terrible conditions and the rest as an instructor at the Gambia Technical Training Institute, teaching math and Computer Aided Design and later as a civil engineer at City Scape Associates.

He married Christiana in 2001 and his son Israel was born in 2005. A group of kind hearted Christians in Cape Breton, Nova Scotia had formed a committee called "Inverness County Welcomes" in 2003/2004 with the intention to assist Sierra Leonean refugees migrate to Canada where they can have a better life. His family was selected out of the thousands wishing to migrate to Canada.

He arrived in Canada on the 2<sup>nd</sup> of October 2006 and 12 days later, his daughter Donalda, was born in Antigonish. He applied for the Marine Geomatics Program at the centre of Geographical Sciences, NSCC in Lawrencetown, NS in the fall of 2007. He successfully completed the program and in June 2008 was offered a full time permanent position with the Canadian Hydrographic Service in Burlington, Ontario as a multidisciplinary hydrographer.

He relocated to Burlington in July where he currently lives. His first assignment is with the UNCLOS program on board the Louis. "Canadians have a special place in my heart for this opportunity given to me and my family. God bless our land as we remain the 'True North Strong and Free'".

### **1.2.9 Fred Learning**

Born and raised in St. John's Newfoundland, Fred began his seagoing career in 1979 with Geomarine Associates in 1979 on engineering well site surveys on the Grand Banks. In 1982 he worked under contract to GSC operating their Underwater Electric Rock Core Drill in the arctic and the pacific and so began his long association with GSC.

Fred studied physics at Memorial University of Newfoundland for three years before returning to the workforce at the request of the registrar. At sea he has held positions as a seismic observer, towed sensor operator, source technician, navigator and ROV technician and tow vessel based iceberg observer. Ashore he works in broadcast engineering, music recording, live sound reinforcement and as a fine art printer.

His hobbies include wood and metalworking, gardening, motorcycles and he is an active member of the Protected Areas Association. He resides in the boreal forest outside St. John's with the moose and wild bunnies.

### **1.2.10 Jonah Nakimayak**

Jonah has been a marine mammal observer and participant in wildlife management programs for much of the last 10 – 15 years, either for government or exploration companies, primarily in the Paulatuk region. He was raised mostly “on land”, having been born in Coppermine, and educated in both Coppermine and Aklavik. Since about 1965, home has been Paulatuk, where he has been power plant operator, lineman, and phoneman, among other jobs. In addition to trapping, hunting, and fishing, he has also done guarding and guiding for search and rescue for the RCMP for about 30 years. He has been a Canadian Ranger since 1988 (search and rescue) and a Ranger Sergeant since 1994, helping with training rangers in the region around Paulatuk.

### **1.2.11 Shigeto Nishino**

He was born in Osaka, near the old Japanese capital city, Kyoto. After graduation from high school in Osaka, he attended Hokkaido University, in the northern part of Japan. He studied ocean circulation theory and was awarded a Ph.D. in Physical Oceanography. After that, he was hired by JAMSTEC (Japan Agency for Earth-Marine Science and Technology) in Yokosuka. At JAMSTEC, he started observational studies in the Arctic Ocean. His current interest is to understand water mass distributions and the ocean circulation, which are related to the sea-ice distribution, heat and freshwater transports, biogeochemical cycles, and their temporal variations in the changing Arctic climate system.

### **1.2.12 Fredrick John Oliff**

Fred was born in Etobicoke, Ontario, where he spent the first 20 years of his life.

Much of his early childhood was spent at the family cottage on an island near Pointe au Baril Station, Ontario. His parents met at a marina at Pointe au Baril, near the lighthouse there. His father John emigrated from England after he left the Royal Navy. My mother taught us all to swim at an early age. He grew up loving being near, on or in the water.

He came to hydrography via a circuitous route having studied Geological Engineering Technology at Sir Sandford Fleming College in Lindsay, rather than take the Hydrographic Survey programme at Humber College which had been his intention following high school. The highlight of his college career was two summers spent uranium prospecting in northern Saskatchewan. He worked for consulting firms for

five years before returning to school to obtain an Honours Earth Science degree from the University of Waterloo. His Bachelor's thesis was on the stratigraphy of the Ordovician-Silurian boundary strata on Cornwallis and Truro islands, NWT, which was his first trip north. Following graduation, after the presentation of a 1947 Old Town cedar and canvas canoe as a graduation present, he found a short-term project doing a hydrographic survey somewhere near the outfall/intake of the pulp mill at Marathon, ON. Little did he know then that this was what he would be doing soon after and since, having now put in over 15 years with the Canadian Hydrographic Service. This is his fourth trip north working for CHS, and the first since falling down the stairs on the Nahidik and breaking his leg. He hopes to complete this job with all limbs intact!

He presently lives in Cambridge with his wife and dog and three canoes in the back of the 110-year old house I call home. The grounds are an assorted amalgam of native plants, shrubs and trees.

He enjoys canoeing, camping, gardening, drinking red wine and travelling.

### **1.2.13 Rodger Oulton**

Hailing from Amherst, Nova Scotia, Rodger is owner of Rodger Oulton's Garage, which he has owned since 1985, and at which he has worked for 40 years. Being in a farming and fishing area, his garage "does everything" – weed wackers, lawn mowers, all marine engines (outboards, inboard/outboards), cars, big trucks, tractors, tractor trailers, manure spreaders, hay bailers. He does all necessary work – body work, undercoating, welding, whatever is needed. His cottage country customers from distant places such as Ontario, Halifax, and outside Boston, save their work for him to do. His local customers understand when he closes the garage to come on the UNCLOS trip, and many want to come, too!

### **1.2.14 Ryan Douglas Pyke**

Ryan was born in Halifax, NS but spent his childhood living in 4 different provinces: Nova Scotia, Newfoundland, Ontario and British Columbia. He fancies himself a competent hockey goaltender, playing to the Midget AAA. Ryan pursued a brief career in cooking after high school, working as a line cook in a few of Halifax's finest establishments before finding his true calling in electronics. While attending college he took a summer job working as a summer student for Borden Chapman who at the time was starting his work on the UNCLOS project. Ryan has been working for Borden at BIO for the past two years, helping him with the UNCLOS project. Ryan married his high school sweet heat Melissa on July 12 before joining the CCGS Louis S. St-Laurent for her UNCLOS 2008 cruise.

### **1.2.15 Dwight Reimer**

Dwight was born in Winnipeg, Manitoba and joined the Royal Canadian Navy at the age of 17, serving in Nova Scotia. In 1974 he left the navy to attend The Nova Scotia Institute of Technology and graduated in 1976 with a Diploma in Electronic Engineering Technology.

After a brief employment with the Dept. of Highways (1 Month), he applied for and was accepted in a term position at the Bedford Institute of Oceanography in the now defunct Marine Ecology Laboratory. He remained at BIO until retiring in 1998. During his time at BIO, he worked as an Electronic Design Technologist and was involved in a variety of instrumented projects for various oceanographic departments as well as provided electronic support in the field and on Science ships such as, EE Prince, Dawson, Parizeau, Hudson, Alfred Needler, Navicula and Lady Hammond. Some of the projects included, the BIONESS Sampler (early Version), the Tucker Trawl, the NetMinder Data System, a Dual Beam Fish Counting Sonar System, The Video Grab, CamPod, BRUTIV and TowCam as well as numerous small projects.

On retirement, he worked for Brooke Ocean Technology for two and half years working on commercial oceanographic products. During this time he was still involved in a BIO project that he had been involved in prior to retirement. Dwight continues to work as a casual and contract person for BIO, GSC(A), St. Andrews Biological Station as well as for the UNCLOS program.

He has been married to Devina for 39 years and has a son Matthew, a daughter-in-law, Amanda and a Grand-Dog, Dakota, living in Newfoundland. Dwight and Devina currently live in Western Shore, Nova Scotia.

Away from work, he enjoys house renovations, cabinetry, radio-controlled airplanes, eating out and the beaches of Cuba.

### **1.2.16 Dale Ruben**

Before coming aboard Louis S. St. Laurent, Dale gained experience monitoring wildlife through jobs with mineral exploration companies. Dale grew up in Paulatuk, then moved to Inuvik with his parents for about 4 years to complete his schooling, and is now living again in Paulatuk. As a teenager, he also lived for a year in Tuktoyaktuk with a host family. He has worked at a variety of jobs, including with JBX Diamond mining, the water company, Paulatuk Housing Association, the Northern Store, and Diadem. He has experience doing GPS-staking for the companies as well as helping with radar checks for the Canadian Rangers. This is Dale's first time at sea. He is delighted to have been chosen by the Hunters and Trappers Association for this trip; he absolutely "loves it!"

### **1.2.17 John Ruben**

John Ruben is from Paulatuk, NWT. He has previously worked with the diamond company, Darnley Bay Resources and has been a member of the Canadian Rangers for 13 years. John has eight brothers and sisters, two living in Edmonton, Alberta, one in Sachs Harbour, Banks Island and another two in Yellowknife. His father is a fiddler and plays at Christmas and in the jamboree, Ikhalkupic which happens every August. John plays hockey and enjoys water skipping with his skidoo.

### **1.2.18 Nelson Ruben**

Nelson joined the UNCLOS team in 2007 as a marine mammal observer, having worked as a big game outfitter doing polar bear hunts since 2000, and working for Environmental Natural Resources doing grizzly bear tagging. He has experience as a



welder for Dewline Demolition for three years and, in the off season, as a small engine mechanic and guard for the RCMP. More recently, his skills provided a natural background for him to step into the job of airgun systems tech during UNCLOS 2008 season. A native of Paulatuk, he has also worked as a roughneck (Canmar) for three seasons aboard the ships Explorers 1 and 3, done airport maintenance for nine years (Paulatuk), and worked for E. Gruben's transport for 5 years doing ice road maintenance. Since 1987 he has been a Canadian Ranger performing search and rescue duties.

### **1.2.19 John Shimeld**

John's childhood was spent in Quebec, Saskatchewan, and Ontario. During high school in London, Ontario he started an apprenticeship in a small machine shop but eventually was lured away by the siren call of academia. John had enrolled for mechanical engineering but, in a teenage crisis, changed to geological engineering when he realized that he could combine his love of the outdoors with intellectual pursuits. After several work terms with the Geological Survey of Canada involving shallow permafrost and gas hydrate field studies on the Mackenzie Delta, John was hooked. He finished a Bachelor of Applied Science in geological engineering from the University of Waterloo in 1991, and moved to Halifax for a Master of Science in geology from Dalhousie University, which he completed in 1994. He continued working as a contractor with the Geological Survey of Canada and, in 1998, was hired by the Dartmouth office at the Bedford Institute of Oceanography. Since then John has worked with a variety of seismic datasets to study topics such as deep water sedimentation, salt tectonics, petroleum systems, gas hydrates, and polygonal faulting offshore eastern Canada. He has also been involved in a variety of field studies, including cruises on the Hudson, Joides Resolution, Louis St. Laurent and also ice camps on the Arctic Ocean. John has been contributing to the UNCLOS project since 2005.

### **1.2.20 Peter Vass**

Peter was born in Welland, Ontario and grew up in Ellerslie, P.E.I. near the DFO Biological Station where his father, Stan Vass, worked from 1952 to 1965. He attended high school in Summerside and continued his education at Prince of Wales College when the family moved to Charlottetown in 1965. He transferred to UNB in Fredericton in 1967. He had summer jobs at the Biological Station in St. Andrews NB and upon completion of his degree at UNB started working at the Bedford Institute of Oceanography in 1970.

His career at BIO exposed him to a diverse series of projects. These included the study of the transfer of organochlorines (PCB's and DDT) and mercury in the marine food chain, larval lobster ecology, plankton vertical migration, distribution of toxins in mussels, toxic mussel crises in PEI, design and fabrication of marine sampling equipment with my colleague Dwight Reimer, effects of mobile fishing gear on benthic organisms and the Swiss Air tragedy. Peter says that the highlight of his career at BIO however, was sharing an office with his golden retriever.

Previous trips to the arctic include Operation CESAR in 1983, multiple trips to the Ice Island and winter sampling on the sea ice near Resolute in 1993.

His experience with welding and machining came from working with the welders and machinists at BIO while working on the fabrication of our sampling equipment. Gradually, he purchased my own enormous collection of tools financed by too many long field seasons and more overtime than anyone would ever want.

Peter retired from BIO in 2004 and started a small design and fabrication business. He was very flattered to be asked by Borden Chapman to join his UNCLOS team. He lives with his wife Debby in Fall River. He has no hobbies, seemingly spending all of his time fixing other people's junk.

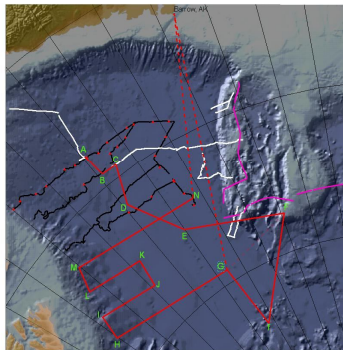
## 2 Diary of the Chief Scientist

### Day 234 August 21, 2008

By 0530 all the scientific staff had arrived at the Canadian Coast Guard base in Dartmouth and awaited buses to the airport. We left the base at 0700 hours (all times are local) on a chartered First Air plane stopping in Iqaluit on route to Kugluktuk. The weather in Kugluktuk was clear and the ship was waiting for us. The three marine mammal monitors and one technical support person who had flown in from Paulatuk to Kugluktuk joined us at the airport. The ship's company from the previous oceanographic cruise had to be flown ashore by helicopter 4 at a time and the arriving personnel flown out. There was plenty of time to exchange information and good wishes. All were onboard for by 1430 for hot roast beef meal. The luggage and fresh food shipment followed.

I had an initial meeting with the Captain Marc Rothwell, Second Officer Catherine Lacombe and the Ice Observer Barb Molyneaux. I left them with a description of the ship's activities during the expedition, a set of line locations and an overview map. Due to the two-day transit to the work site and the minimum of three days to prepare the seismic gear we will not sail until tomorrow. This gives the engine room time to address a number of issues as well.

The purpose of the voyage is to collect seismic data for sedimentary thickness and bathymetry to determine the foot of the slope. These data are needed in order to meet the requirements of article 76 of the United Nations Convention of the Law of the Sea (UNCLOS) treaty that Canada signed in 2003. This year's data collection exercise is a two ship experiment for a portion of the voyage. On September 8 or 9 we meet the USCGC Healy. This occurs in 2.5 weeks.



**Figure 2.1 Sketch of survey plan. Red lines indicate planned seismic lines, black indicates seismic data collected on the 2007 Louis S. St. Laurent cruise, and white are existing USGS lines in the region.**

Notes for the first meeting:

- Safety Issues:

- Safety first
  - Field form: access to GSC field guide
  - Spills at Sea training
  - Only authorized people work with the equipment
  - Drinking policy
- I will post a list of all the ship's company in the lab
  - Daily routine –
    - At 0800 there will be a meeting of the technical staff -changes will be pasted to the Bridge
    - At 1900 there will be a discussion. All are welcome, and all group leaders must attend.
    - The daily intentions will be written up and posted.
- We did a roundtable to introduce one another.
  - Volunteers to take pictures of the scientific staff and the crew
  - The work groups are:
    - Technical support for the seismic system lead by -Borden Chapman
    - Hydrographic group lead by -Jon Biggar
    - Marine Mammal monitors -Nelson Ruben
  - Forms: Shigeto to fill out GCS field forms
  - General
    - Cruise report in WORD no exceptions
    - Debbie writes up daily intentions
    - Marine Mammal Monitors
    - Work begins as soon as ship sails
    - Mealtimes 0730, 1130, 1630 any one with allergies or special food requirements contact the Chief Cook

**Day 235 August 22, 2008**

+6.7°C skies are grey, light winds and warm

The ship was at anchor overnight. After the long journey yesterday, a good night rest was appreciated by all. Most were up early due to the 3 hour difference between Halifax and Kugluktuk.

I met with the Captain; there will be a ship's orientation today, a plenary session with the Captain after lunch, and the ship will sail after Jim Etter has fixed the sonobuoy antennae to the mask. The ship will sail slowly to way point A. Below the list of waypoints for the cruise.

**Table 2.1 Planned expedition waypoints.**

Point	Longitude	Latitude
A	-140.3262611	73.800225
B	-140.6096472	74.60641667
C	-142.5998556	74.63440278
D	-140.5777167	75.91069444
E	-144.9354583	77.6958
F	-160.4803472	78.73248056

F1	-148.4826417	81.80319722
G	-147.1109083	79.59161667
H	-124.8087444	78.65411667
I	-126.2231444	77.85631111
J	-135.62535	78.48029444
K	-136.5984333	77.55906389
L	-128.1444	77.022825
M	-129.7769778	76.25402778
N	-148.5998528	76.98053333

Discussion with the marine mammal observers led to the following schedule for watches to be set up as soon as the ship sails. Under Jonah's guidance we have set up a system for recording notes from the exposed flying Bridge. The Boatswain is busy when opportunity allows will be asked to set up a stool on the flying Bridge as well.

**Table 2.2 Marine mammal observer schedule.**

Monitor	Shift Start	Shift End
Jonah	0800	1600
John	1600	2400
Dale	0000	0800

Borden's group was working steadily to set up the seismic system and discovered that the air bottles exchanged by the certification company do not have the same size fittings as the original bottles. The chief engineer Mark Cusack has been called to assist in solving the problem.

Paul Girouard is working with the ship's technician to set up the computer network. There are two separate networks onboard - one for the ship and the other for science. Staff cannot be on both. The choice is to be on shipnet and have access to email system or on the science network and be able to move data around the ship.

Paul and I, with considerable help from the Captain and the ship's technician, were able to make a call to John Halpenny on the Iridium phone. The gravity meter is not operating properly and he must be contacted before the end of Friday.

Mariah, one of the ship's cadets and Donald, the junior hydrographer, are taking pictures of the ship's company.

At 1100 local the ship's engine started and the ship lifted anchor.

By 1900 the gravity meter problems had been solved. Borden had located a malfunctioning electronic component and replaced it. All the electronics in the seismic laboratory are now operational. The starboard compressor is being prepared for operations first, the port one will be used only when required and will not be tackled until time allows. The problem with the high pressure fittings on the air storage bottles has been deemed under control so that we were able to sail.

Jon Biggar had to calculate a new grid for the spot soundings because the cruise track had changed and he had not been notified of the changes. This was completed today and their sounding systems are operational. Watches will start in a day or so. At the calibration site for the airguns, he will need to do a bar check and a sound velocity profile (SVP) to full depth at the start of the survey work.

Shigeto Nishino showed us the area the oceanographers worked in during the previous cruise and the areas along our proposed track that he wanted to release expendable conductivity, temperature and depth (CTD) buoys. He asked for the ship to be stopped to carry out the measurements in ice, but this is not possible. In discussions with the oceanographic group prior to sailing, it was clear they could take part in the cruise provided they did not require the ship to halt to do their measurements. Jon Biggar said based on his experience the expendables could be launched when the ship was moving.

## **Day 236 Saturday August 23, 2008**

+4.3°C overcast

The ship is steaming at 10 knots and our position was 70° 04' N, 120° W at 0730. The winds are 10-15 knots and there is a possibility of drizzle and light rain. We should be able to start testing at 2300 hours on Sunday. The first ice should appear tomorrow.

Safety issues: Last night at 18:00 hours Nelson got a fragment of metal in his eye from the grinding activities on the tow sled while he was working on the air guns suspended from the tow sled. The nurse looked at his eye and removed the fragment and covered his eye. At 0830 she examined the eye again and the eye had recovered. He returned to work. A hazardous occurrence form was filled out and safety measures implemented on the Quarter Deck to reduce occurrences. The measures taken were:

1. All technical support people were made aware of the problem.
2. The location safety glasses were pointed out.
3. It was suggested individuals should avoid areas where grinding is taking place.
4. We commit to more careful observation of all deck operations.

Prior to lunch, when I was distributing pictures of the scientific staff to put up on the door of the seism lab, I noticed Fred Oliff using my 3 lb weights that I had put aboard prior to sailing. I asked where he had found the weights and he said they were in a cloth bag with books and that was all he was aware of. I fear that some one had access to the lab and purloined the rest of the items in the case and the case itself. This means I will have to make do without my safety shoes and all my warm Arctic clothing for the rest of the trip. I have asked the Boatswain and Chief Officer to look out for the black fibre case. As well I talked to Jay who is in charge of the stores for the ship and visits all the nooks and crannies. Ryan who carried the fibre case on board is frankly relieved that he did not misplace it.

There will be an entertainment committee meeting at 1300. Most of the staff is busy so that it was fortuitous that Debbie volunteered to attend. A quick survey of the science staff brought up the following possibilities: Jonah would like a cribbage tournament, John Shimeld is a skilled guitarist and Donald plays the piano.

At the 1900 meeting the activities of the day were summarized.

- o The seismic team lead by Borden worked steadily all day. They had a number of unexpected difficulties. The  $\frac{3}{4}$  inch dyes for cutting the synflex hose are not aboard the ship - unfortunately, there are two sets of  $\frac{1}{2}$  ones.
- o Jim Etter spent the day working on the reels for the hydrophone array. The reels spool out but not in (except on the key pad on the reel which is not a spot where the reels can be sensibly controlled). Jim managed to jury rig a system that allows motion in both directions.
- o The air tanks are not connected to their fittings; a problem that plagued the group yesterday and required Peter Vass to do some unexpected welding.
- o The gravity meter that was repaired yesterday continues to operate.

Borden estimates it will take two more days work before we are ready to test the seismic equipment. We should be on site before that. This will be an opportunity for Jon Biggar and the hydrographic team to do his bar-meter test and deep water velocity calibrations.

Tomorrow the technical team must get the signal lines from the radio room for the sonobuoys connected back to the seismic lab. They must also start to lay out the streamer. All the serial numbers will be recorded so John can get an accurate length. The streamer will be arranged thusly:

- Flotation cable
- 1 anti vibration section
- 2 stretch sections
- 2 active 8 channel section
- 1 anti vibration section
- 2 stretch sections
- Tail rope

At 2000 a meet and greet event was held in the lounge. The galley provided hot appetizers. The officers, crew and staff chatted amiably with each other. The piano was played by Donald and Keelan, one of the cadets from the Coast Guard College. Most of the technical staff went to bed early tired from climbing stairs on the LSSL for 12 hours solving endless problems.

## **Day 237 August 24, 2008 Sunday**

Low lying fog, light winds, 100 nm north of Banks Island, 180 nm to station A

Note that some of the decks are slippery due to ice. At about 0400 the ship hit the first ice. While it's still only a few tenths, the erratic motion of the ship and the fog horn probably disturbed sleep.

The Officers are dressed in the white shirts because it is Sunday and inspection will take place today. The first ice reconnaissance flight of the trip is at 0800. This means that the seismic crew will restrict itself to work that does not involve the flight deck.

At the 0800 meeting Borden brought up two safety issues:

1. Nelson Ruben getting a metal splinter in his eye in spite of wearing glasses and
2. The high pressure bottles must be secured with a heavy bar in case of sudden release of pressure.

The major effort of the technical group this morning will be in getting the starboard compressor started and running high pressure air through the lines. When the flight operations are over, work will begin on assembling the bundles for the high pressure hoses and electrical cables that will connect to the air guns.

Reports from the 1900 meeting:

- A successful day was reported by Borden.
- The network is up and running.
- The sonobuoy electronics can be monitored and controlled from the seismic laboratory.
- Sufficient work on the starboard compressor has been accomplished that it will be run up today.
- The “bundles” of electronic cables and high pressure hoses with their protective wrap and huge clamps for the stress member were assembled on the helicopter deck.
- The parts for the streamer have been assembled and are ready for assembling on the helicopter deck.

Debbie wrote up the first plans for tomorrow, we call them the daily intentions:

## **Daily Intentions – 25 August 2008 (Monday)**

### **Seismic Systems**

Work will continue on the quarterdeck readying the seismic equipment for test. The streamers will be assembled and the various components can then be combined into their configuration for collecting data. It is unlikely any seismic gear will go in the water on Monday.

### **Bathymetry Systems**

Two tests are planned, both with the ship on station:

- Bar Test – this will be in the morning (~0900), lasting about an hour.
- SVP (velocity profile) – this will be in the afternoon (~1315)

### **What to look forward to**

If the seismic systems come together successfully on Monday, testing of the gear in the water will begin on Tuesday. Once the gear is successfully tested, an experiment to collect the airgun signatures will be done (hopefully Tuesday, but more realistically Wednesday?). Following the airgun signature experiment, normal profiling can begin (Thursday?).

When normal seismic profiling begins, Jon Biggar will probably begin spot soundings using the helicopter (Thursday?).

The write-up along with the test plans for the airguns and streamer were handed to the Captain as well as Jon Beggar’s location for his spot soundings. This was at about 2130, later than expected, because the Chief Engineer was running a yoga class attended by the Senior Engineer, the Chief Mate, the Logistic Officer, the Nurse, two Oilers, Debbie and myself. Onboard activities have certainly changed for the better in the last 35 years.



## Day 238 Monday August 25, 2008

Light winds at breakfast, fog patches

The winds are expected to climb to 20-25 knots. The temperature was above freezing all night at about 3°C. The ship reached its destination in the night and we were hove-to in the morning near 73° 48N, 40° 22 W. This is the position of waypoint A, the start of the UNCLOS seismic program.

At the health and safety briefing the technical staff was reminded to see the nurse today. This is required at the beginning of every cruise so that she will have an accurate health assessment of all onboard. Jon Biggar needed the drift of the ship to stop for his bar meter test and SVP. Borden also wanted the stern of the ship protected from the wind so it would be more comfortable working on the quarterdeck and aft of the helicopter hangar.

To comply with the needs of the technical staff I needed to consult with the Captain. I found the Captain and Chief Officer at the breakfast table and they invited me to drink green tea and honey with them. The Captain called the engine room and one engine was put online so that the LSSL would be able to maneuver to meet the needs of the science staff.

The helicopter pilot expressed concern that if Jon was working on the ice and hurt himself he would not be able to leave the machine to assist him. The solution to this was to ask for volunteers to fly and if help was required they would be paid overtime.

The sea was too rough for Jon to do his bar-meter test. The test involves hanging a cone vertically over the side of the ship. If the seas are rough this cannot be accomplished. He can try his SVP measurements that are less sensitive to sea state and if necessary can put off the bar-meter test when calmer seas are found.

At 1630 I was called to the Bridge to discuss for a call from Polarstern. They had a medivac underway and for a while it looked as if we were going to participate in it. The LSSL started out on the rescue mission and it took until about 2030 to get back on station. Wilfried Jokat took the opportunity to ask for our track lines so that he could possibly connect to them during his survey. I sent them off in an email.

The streamer was assembled today. John Shimeld carefully measured and Paul Girouard recorded and inventoried all the components. The towed array will consist of 13 different sections and will be 300m long. It took considerable effort after supper to set the seismic computer that communicates with the streamer. They are ready for testing tomorrow.

The starboard compressor was tested today. This year it appears to be operating without as many vibrations as last year due to the diligence in repairing and maintaining it. Rodger has started to get the port compressor ready for operation. The high-pressure fitting on the air storage bottles leaked so a bottle from 2006 survey plus an oxygen bottle have been put in the rack. The port tow sled is 95% complete and there is another 2 hours of work left on the starboard one.

The marine mammal watches were discontinued while we were on station without my notification. This and other small incidents have caused me to ask Nelson to

request them to be more vigilant. I would like Jonah to attend the 1900 meetings as well.

After the science meeting, Debbie wrote up the daily intentions and we distributed them to the Captain, Chief Officer and the seismic laboratory.

## **Day 239 Tuesday August 26, 2008**

Light winds 14-20 knots, we are still 270 nm West of Banks Island

Notes from the 0800 Safety Meeting:

- Borden reminded his group that safety hats and steel toed shoes were imperative with over the side work planned for this afternoon.
- Fred is checking bolts on all the airguns because he found a loose one yesterday.
- Rodger and Nelson are working on the port compressor.
- John and Dwight are continuing to work on the configuration of the hydrophone array and its computer controller.

Jon Biggar plans to do a SVP this morning after the deck crew has reconnected the winch. It was disconnected because they thought it was only used by the oceanographers on the previous cruise. The SVP was lowered at about 1120.

Prior to the streamer tests, the Captain had all the Mates assemble on the Bridge to be given an overview of the seismic equipment. Borden described the seismic system and the implications for the Mates:

1. It is important not to run the third engine and never to come astern.
2. The airgun sled is towed at 35 ft depth and the 1000 ft streamer is attached to it.
3. It is supposed to be neutrally buoyant but of course that depends on the water temperature, so if the ship must come to a halt the equipment can be safely recovered.
4. If turns are required, the ship's crew is asked to make them broad enough so that we do not cross over the streamer.
5. If the seismic profile is terminated before the end of a line, a 2 nm overlap is required at the start of the deployment.
6. The line spacing is 50 nm to allow for a ten nm deviation from the line if required by the ice.
7. For velocity information, expendable sonobuoys will be deployed at a maximum rate of 1 every 4 hours. The Bridge will be notified before they are put in the water. The Bridge is asked to record the time of the deployment, the position and water depth. We will provide sheets to the Bridge for this record keeping. No help from the deck crew is required for the actual tossing of the sonobuoys into the water.
8. The Captain will have one seaman on the Quarter Deck at all times to supplement our watch keepers: 1 for the compressor, another for the electronics in the seismic lab and a third the hydrographer tending the echo sounder.

The August 26, 2008 instructions written by John Shimeld and vetted by the Captain Rothwell

The three streamer tests described below should be conducted along a constant

heading and with the wind from astern. In total, the operation will require 7-8 hours.

1. Starboard streamer towed from ship's rail
  - a. deploy the streamer at 2 knots
  - b. allow ship to coast to full stop (no propeller rotation); noise measurements for ~20 minutes
  - c. bring speed to 3 knots; noise measurements for ~20 minutes
  - d. bring speed to 4 knots; noise measurements for ~20 minutes
  - e. maintain 4 knots with bubbler system on; noise measurements for ~20 minutes
  - f. reduce speed to 3 knots with bubbler system on; noise measurements for ~20 minutes
  - g. allow ship to coast to full stop (no propeller rotation) with bubbler system on; noise measurements for ~20 minutes
  - h. recover streamer
2. With the port streamer towed from ship's rail, repeat the same steps as above.
3. With the port streamer with drogue chute attached, towed from ship's rail, repeat the same steps as above.

The streamer tests began with running the new winch with the hydrophone array out into the sea. Jim Etter was the winch man and the winch performed flawlessly; a great improvement over last years hand hauling. The first several hours of the tests had to be redone because the centre shaft was running. This was the one thing we had asked not to happen; however, we definitely proved it was noisier than with the exterior two props running. The pleasant surprise is the bubbler does not affect the noise on the streamer. Closer examination of the data will have to be made to confirm this observation. On the test of the port streamer it was noted that channel 13 in the second active section was not working. This was a section that had been sent to Geometrics to be refurbished.

At 1900 we had our regular meeting and the Captain attended but the representative from the marine mammal observers forgot. I reminded him when I saw him. The implications for their group are that there will be continuous watches from noon on so they must be ready for the night shift.

Wilfried Jokat, chief scientist on the research vessel Polarstern, which also working in the Arctic Ocean, sent the location of their first seismic line on the Mendeleev Ridge. I plotted it relative to our lines.

### **Day 240 Wednesday August 27, 2008**

Winds 10 knots, +3°C sunny, water temperature

Notes from the 0800 meeting:

- Borden reminded his staff that if there were using the tape supplied by Geometrics to wrap the fittings on the streamer to wear gloves because the tape may contain PCBs.
- The last streamer test was being prepared for as Jon Biggar was setting up to do a bar test to 400m. The calmer seas today make this possible.

John Shimeld was up late studying the plots from the streamer tests. The low-velocity noise at low frequencies was troubling him. He had text books out and was searching his mind to understand a wave that traveled at a mere 250 ft/sec. This morning he was elated to find on page 170 of the streamer manual (that had been downloaded yesterday before the web server went down) an example of streamer strum. This type of vibration is caused by turbulence along the streamer. The correction is fairing that we do not have.

Jon Childs, the Chief Scientist on the Healy, lives near Geometrics so he will be contacted along with Geometrics to pick up a fairing cable and hand carry it to the ship. This is a really useful outcome of the joint experiment.

Jon Biggar did a bar test today, but because the ship was still moving due to the sea state he will try again when we are in the ice and the ship is stable.

The streamer tests went smoothly but the calibration for the airguns had to be aborted because the digitizing box would not work. Therefore we prepared to start the first line at about 1600. Unfortunately the GeoEel software was unstable. John rebooted a number of times and in desperation called the company in California. They suggested hardware problems that we did not think likely. John cleaned the registrars on the computer and it eventually started to acquire data. Unfortunately, he had to remove the filters that reduced the low frequency noise. By 1945 the guns were firing and we were on line. As the day wore on the sun shone brightly and even warmly on the quarterdeck and the seas continued to diminish.

## **Day 241 Thursday August 28, 2008**

Calm seas, 1.3°C ice free waters

At the 0800 safety meeting it was noted that the Captain provided a sea watch for the 1600 to 0800 to ensure that the seismic watch keepers were not alone when they were inspecting the gear over the side of the ship. At 0200 in the morning, one of the three guns stopped firing but we continued due the good signal to noise ratio in the flat calm seas. The fact that we ran with two guns successfully on the last cruise also contributed to the decision. The ship continued along the line AB.

Today is the Captain's birthday and a card is being prepared for him. At lunch hour the crew gave him a letter on how they appreciated his abilities to deal with management especially translating their issues to land lovers. In order to help him with this ask he was given a manual called "The Arctic and Antarctic for Idiots". This presentation was followed by cake and Happy Birthday carol.

At 1500 the gravity meter was noted to be hard against its stops. I tried contacting Borden but he must have been in the compressor container, so Ryan was called and he got the meter powered off and back on again.

In bright sun and low winds, the airguns fired until about 1600 when the second airgun stopped firing. An attempt was made to put it on manual firing but this did not solve the problem. Therefore, the Bridge was contacted and ship started to circle about 10 nm from the end of segment BC. After supper the sled was brought in. The damage on the starboard sled was limited to a sheared airline on the mid ship gun and a connector disconnected on one of the parallel guns. At the same the

compressor developed a leak in the high pressure stage. It was diagnosed as due to two stretched O-rings that were newly refaced and replaced.

The situation was seemingly under control when it was noticed that the leakage on the streamer was high. It had not been powered down during the process of bringing the airguns aboard. This necessitated bringing the sled back on and changing out the deck cables.

The sled was put back in the water with the boatswain and his crew in only twenty minutes from the time he was called until returning to his cabin. The airguns fired and we were on line after a superbly executed turn as recorded on the Regulus navigation screen. Unfortunately, the system that displays the shot break was not working. Jim assured Borden the connections had been properly made on the airgun. There must be a fault in the electronics. Borden and the lab became quiet as he concentrated on the problem. He removed the controller from the rack and replaced a cable; the signal and display returned. The seismic reflection profiling was back in operation with a short gap in the line. The technicians, except those on watch, left the laboratory after 15 hours of exhausting work.

### **Day 242 Friday August 29, 2008**

Foggy, calm seas, water temperature  $-0.7^{\circ}\text{C}$ , air temperature  $-2.3^{\circ}\text{C}$ , winds SE 5 knots, 278 north and west of Banks Island, expecting ice today

At 0630 I contacted the seismic laboratory, the small 150 cu in airgun failed at about midnight. The sled is not pulled from the water unless one of the larger airguns fails.

During the 0800 safety meeting, it was noted that the ice on the hand rails overnight had disappeared and the decks are not yet slippery. The deck cables have to be rebuilt on the helicopter deck. Rodger continues to work on the compressors with Nelson supporting him.

The gravity meter was up against its stops again today and had to be reset. Borden went through the spare parts and did not find a replacement power supply. This is the second time in two days. This is disappointing as we were crossing the gravity low that is the most distinctive feature in the southern Canada Basin

John spent the day processing data and was able to plot the first 4 lines. The flat-lying sedimentary arrivals are clearly imaged overlying a basement at about 9.0 seconds two way travel time. Basement appears slightly higher on northeasterly side of the graben. The biggest surprise was strong reflectors shallow in the basement along segment 4.

The first 4 sonobuoys were plotted and there are strong refractors for nearly 8 hours. Unfortunately there are also strong noise bursts. It is fortunate that sonobuoy 3 recorded the start of the noise episode, so we may be able track it down.

It was flat calm all day and about 1600 the ship entered water with about four tenths small flows. The sun came out and it was rather pretty.

One of the problems with the air guns failing on the sleds is related to the hoses. It was discovered the hoses that had separated from the connectors on the airgun were those not properly crimped because two sets of the wrong sizes were packed. The hoses made up last year lasted throughout the deployment. The needed dyes were

on the CCG Hudson. The USCGC Healy will deliver the missing dyes but not until September 8 or 9 when the two ships rendezvous.

Notes from the 1900 planning meeting:

- Barb described the process she will use for documenting the ice conditions. She will take a screen capture of the RadarSat from the Ice Nav and annotate with date, time water temperature.
- Borden went over the days technical accomplishments that included rebuilding the bundles for the part sled. The O rings on the fourth stage of the starboard are still stretching and have to be replaced regularly and we have only 4 left.
- Jonah reported that no marine mammals were seen. He was concerned about ice on the flying Bridge and I asked the Chief Officer to salt it in the morning for him.

At 2300 I got a call from Borden that the pipe with the problem O rings had severed. The ship had just started the D to E leg. The airguns were turned off. The equivalent pipe was taken off the port compressor. Peter Vass took measurements and started the process of rebuilding the high pressure pipe for the port compressor. Meanwhile, the software failed again. After restarting and failing to acquire navigation data even though it was reaching the computer, checking cables and hardware, the second computer with new software was put in place. All modifications to the software to remove low frequency noise that help with data processing but could interfere with the program operation were removed. This will degrade data quality but we must acquire some data. This system did acquire data after several restarts so is not stable. By about 0145 on day 243 the airguns were back on and we were collecting seismic sections again.

### **Day 243 August 30, 2008, Saturday**

Sunny several tenths ice in small flows, bears tracks being reported regularly, -3°C

The repaired compressor and electronics worked all night. At the 0800 safety meeting it was noted care should be taken on the decks. The work on the high pressure piping was re-established.

John, the Captain, the Chief Engineer, Chief Electrician and I discussed the possible causes of noise on the sonobuoy and reflection records. It was agreed it was probably electrical interference and they are willing to do a series of tests by starting and stopping various components of the ship's extensive power plant to discover the source of the problem. Their helpfulness was a breath of fresh air. We will put off doing the tests until Borden has time to deal with this problem.

The fourth stage discharge pipe and coupling moved from the port to the starboard compressor began to leak. This is the same part that failed early in the program last year. If Peter Vass cannot manufacture a replacement part, we will not be able to generate compressed air for the program and we will have to return to port.

The ice conditions were light all day and we continued to collect good quality seismic reflection images. Borden tried using a different frequency for the sonobuoys so that the walkie-talkies used on the boat would not put as much noise on the records. John thought the frequency change resulted in a diminished signal range. So far we

have launched 10 sonobuoys in about 3-4 days of surveying so we will cut back to 2 per day the total number available is 70. John Shimeld and I thought we would launch more in open water conditions where the range would likely be the longest and also we had fewer velocity measurements from the central part of the survey last year.

Notes from the 1900 meeting:

- Barb reported that the water temperature was now at  $-1.3^{\circ}\text{C}$ . Nilas and white nilas were forming especially further North along are planned track.
- Borden said that the replacement part for the discharge pipe was three-quarters complete.
- The air gun sled has had 40 hours of towing without any maintenance.
- The port compressor is now ready to be started if required.
- Several hours are required to replace the software on the seismic reflection acquisition system. Hopefully, Jon Childs on the Healy will have replacement software if not he will use the ghost software to duplicate the program we have.

Jonah's review of the day was that he had seen many bear tracks but no animals as yet. He stated his belief if the bears were walking on the ice there was no need to turn the guns off. We thanked him for his comments but said we would continue with the process because we had promised to do so. However, we will ask Fisheries and Oceans to review this rule.

Jon Biggar would like a bar-meter check on the sounder the next time we are stopped and to begin spot soundings. John Shimeld summarized the results from his extensive noise tests. A few of the surprises were that the bubbler and central shaft did not add noise to the record. Electrical noise from the ship is a significant contributor. A 10 Hz filter is useful to clean up part of this problem

The Chief Engineer ran his every 3 night yoga class. Due to the computer based golf tournament (Wii) a few of the regulars participated in that activity instead.

## **Day 244 Sunday August 31, 2008 $-4.4^{\circ}\text{C}$**

Foggy, 300 nm NW of the tip of Banks Island

At 0530 Dwight called me; we were beset in the ice. About 5 minutes later the bubbler was put on and the ship started forward again. About 10 minutes later the ship was stopped again by the ice. In consultation with the Captain, we decided to stay on the spot and pull the gear at 0700 after the crew was up and before breakfast. Borden was called at about 0630. (He managed to get 8 hours sleep) The reason for the call to him was that the digital readouts indicated a significant leakage in the streamer. We decided to protect the streamer because it is labour intensive to find the faults, expensive if the streamer is destroyed and a time consuming to assemble a new streamer.

The gear was on deck in about 15 minutes. The only damage to the airguns and sled was a single high pressure hose. The streamer was the main issue. The software for acquisition was turned on to check continuity and the streamer leakage read out was within an acceptable range. Now the team can concentrate for three hours repairing the computer.

Jon Biggar and I sent the weekly message. Jon spoke with the Captain who was on the Bridge to confirm the timing of the bar-meter check for the ship's echo sounder and the timing of his flight to begin spot soundings today. An ice reconnaissance helicopter mission was first on the agenda today.

Safety issues: the Chief Officer announced on the ship's public address system that the decks were slippery and that they had put salt on them.

It was most of the day before the compressor was ready to make air again. At this point the ship's engines had to be restarted and we had to get back on line. Due to a misunderstanding with the bridge, we did not get sufficient overlap so another half hour was required before the gear could be streamed.

During this process the leakage on the streamer soared to 1375 units - turning the detector on and off solved this problem. The guns were slow to fire. They had obviously started to freeze up, producing a weak sound. Borden cycled through the firing of the guns manually and they stabilized. They were able to leave the lab and get supper at 1715.

During the day because the plotting had been slow from my personnel computer, I decided it was time to defragment it. It took about 6 hours. I hope that it will be able to respond more quickly now.

In the Captain's dining room for the 5 course Sunday supper the scientific guests were Debbie, Jonah, Paul and Donald. The Captain, Chief Engineer, First Officer, and E/R Technician Sherry, Officer Cadet Bennet, and Nurse Maggie were also present. The rotation plan for Sunday supper is shown below.

**Table 2.3 "Captain's Dinner" schedule.**

<i>August 31</i>	<i>September 7</i>	<i>September 14</i>	<i>September 21</i>	<i>September 28</i>
Paul Girouard	Jim Etter	Peter Vass	Dwight Reimer	Jon Biggar
Jonah	Dale Ruben	John O. Ruben	Nelson Ruben	Borden
Nakimayak				Chapman
Debbie	Ruth Jackson	John Shimeld	Fred Learning	Kelley Brumley
Hutchinson				
Donald Kalley	Shigeto Nishino	Fred Oliff	Rodger Oulton	Ryan Pike

At the 1900 meeting attended by the regulars Barb, Debbie, Borden, John, Jon, Paul and Shigeto. Debbie came back and reported on the care taken on all five courses and the congeniality at dinner. She had a chance to chat and learn more about all the dinner participants.

Barb continuously reminds us that ice is forming here weeks early than last year and of course, it will be getting thicker as we move north. The conditions do not favour flying because there is fog.

The major repair to the compressor seems to be holding. The fourth stage high pressure pipe has been replaced on the port compressor. The sonobuoy reception has been moved to channel 74 to remove it from the range of the walkie-talkies.



Jon accomplished a bar check on the sounder and found an anomaly at 200 m that is not yet explained.

## Day 245 Monday September 1, 2008 Labour Day

– 4°C about 6/10 ice, new ice is forming, foggy

At the safety meeting where there were no concerns were raised, the plans for the day were reviewed. Since all three airguns are still firing, the compressor worked all night and the streamer is deemed operational; a number of other issues can be dealt with. It is worth noting that the leakage on the streamer is reading 1300+. Borden noted that every time Dwight gets up off his padded chair the read out increases. He thinks static electricity has burned the sensor out. Jim sits on a wooden stool and this does not occur during the day. The data on the recorder in the seismic lab are exceptionally clean this morning. On the near trace display in the lab I can identify the 8.00 second two way time arrival labeled by Art Grantz as the 100 Ma event. The third smaller guns may be adding high frequencies and ice cover dampens wave motion and associated noise.

Peter and Nelson are working on the port compressor preparing it for use when needed. Ryan is modifying the high pressure lines on the port sled again preparing it for swapping when required. Rodger and Jim are doing watches in the compressor container and seismic lab respectively.

Dale Ruben came by after his watch. He had his logo for the marine mammal watchers ready for scanning. It has a symmetrical composition that is pleasing with the three marine mammal watchers surrounded by a variety of sea creatures. He left with more paper to work on other compositions.

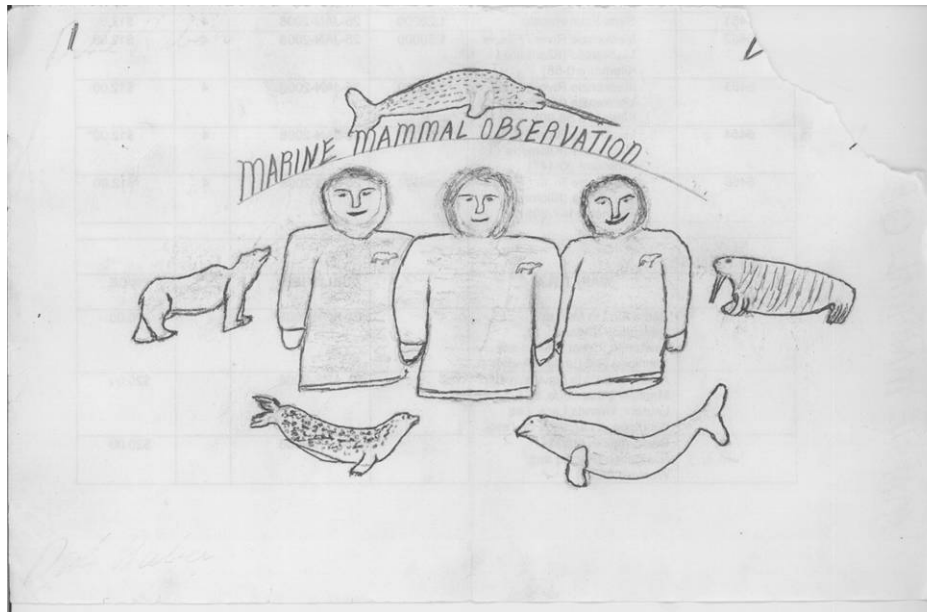


Figure 2.2 Draft of Marine Mammal Observer logo.

An email from Jacob arrived asking about the compressor and computer software problems. I responded. I also sent information to John Halpenny asking for advice on the gravity meter problems attaching the data readings for the cruise to date.

Borden arrived at my office with John Halpenny's email. At that time he noted that a release valve let go on the compressor dumping high pressure air next to Nelson. The compressors require constant attention. A gauge vibrated off the starboard compressor today and was shock mounted on again. The engine room provided the gauge. The port compressor exhaust housing is vibrating strongly and it is not even running. A series of brackets are being built to control this situation. Nelson and Peter are working closely on these projects.

The ice was thick around noon and it forced us about 10 nm off course. Barb had flown over the route by helicopter and this was the best way forward. The Mates gradually worked the ship back on course. The ice charts indicate that ice along the next 120 nm should be only a few tenths. Beyond this we do not have ice images and it is difficult to download them now. The Sat B is showing good strength all day but Barb could not acquire any data. This is a bit worrisome as we continue north. Jon Biggar was able to begin flying spot soundings from the helicopter after lunch. He did a sounding near the ship and there are lots of still and videos of the activity.

## **Day 246 Tuesday September 2, 2008, Tuesday**

-5.6°C foggy, a few tenths ice in small flows, hoar frost on the starboard side

At the 0800 safety meeting, there was less pressure than usual on the technical staff because the seismic equipment had run smoothly all night with 3 guns still firing. This is a significant issue for safety because it allows for greater attention to detail. Today, the goal of the technical staff is to get the port compressor running.

The sonobuoys have been switched back to channel 84 after 3 failures on the lower frequency channel 74. The lower frequencies should have had a greater range. It is possible there should have been an adjustment for the different channel? The sonobuoy presently recording has a good signal to noise ratio. Paul provided Debbie and me with the location of the sonobuoys to date so we could better decide when and where she wanted the next one deployed. The seismic section is of excellent quality as well. On the near trace recording you can see flat lying sedimentary section overlying basement. The sedimentary section is thinner near the Chukchi Plateau.

Debbie plotted the tracks of Healy multi-beam work and Jon Biggar looked at the bathymetry on the map. Three new way points were subsequently given to the Bridge between F and G. John Shimeld is concerned he cannot do a deconvolution of the data due to the lack of calibration of the airgun array. The strumming of the cable adds to his problem with using the water column signal. Borden will look at the electronics and at the end of the FG segment a complete calibration of the airgun array will be attempted again

I spoke with the Boatswain Bob about Jonah's concern that his chair on the raised plywood platform on the flying Bridge would move in rough weather. He sent Carpenter Eugene up and he used L shaped flanges to secure the chair. Captain Marc was also up to see Jonah today to make sure he was aware that he was welcome to

do his watches on the Bridge. Jonah assured me he was warm and comfortable where he was.

A health issue came up today that 7 of the scientific staff had not checked in with Nurse Maggie yet. I reminded them to see her.

Borden and Ryan spent a considerable portion of the day working on the new electronic panel for monitoring the port compressor when it is running.

At the 1900 meeting Barb reported that the water temperature was now at  $-1.8^{\circ}\text{C}$  the freezing point. The ice concentrations would be four to seven tenths over night and loosen again. Borden noted that the compressor had run for 53 hours and the seismics for 48 hours. The annunciator system was set up on the port compressor that is lights to indicate to the operator they needed to contact the lab and an eventually an electronic system to monitor temperature, pressure and produce a spread sheet.

Jonah has seen only gulls today and Dale had noted three seals on his watch. The new sheets that Paul produces with an extra column for the distance the marine mammal was from the ship pleased Jonah. He did not like the fact that he had to return to the Bridge to relieve John at 16:30 for supper. I asked Nelson to solve this problem.

Shigeto will begin deploying XCTD tonight. Because he does not have a phone we got a pager for him. The position of his first XCTD was put into our navigation system in the lab. He will be called every 18 nm.

Borden reminded everyone that the decks were slippery. On all stairs/ladders one hand must be on the railing. This was repeated to the technical group at their change of shift as well. Two of the twenty scientific staff have broken their legs at sea falling on stairs.

### **Day 247 September 3, 2008, Wednesday**

-5 °C, good visibility, 860 km of seismics to date

On the Bridge this morning they had been in contact with the Healy. I asked if in their next contact they would enquire about ice conditions along their route as we were headed north where they had been.

At the 0745 safety meeting all had gone well over night on the port compressor but Fred Learning had noticed a new rattle. Borden asked them to please use the infrared camera to take detailed pictures and to leave it in store mode so they would have records. The compressor needs scheduled maintenance so they are going to bring the equipment in after lunch. The streamer has small screws that hold the sections together so they will be checked. The first gun on the shot monitor also appears to be drifting so the solenoid should be replaced.

The sonobuoy died after 4 hours we had planned to launch another but the scheduled maintenance will interfere. There also appears to be a problem with the receiver so Borden was working on it.

The LSSL helicopter will over fly the Healy today as the ship approaches us. Ryan went with the First Officer to take pictures with the CBC video camera.

At 1220 the Healy reported it was recording our airgun for noise tests. I tried delaying the turning off of our guns until the Healy could be contacted. They got back to us and said they would try again later so the shut down took place.

At 1230 the working seismic system was stopped and brought on board for inspection. This scheduled maintenance stop also allowed the engine room to due a vibration tests in the tiller flats. While the ship drifted for two hours the hydrographic team did a sound velocity profile (SVP). The air guns and air hoses were in good shape on retrieval. One gun with a solenoid that was deemed to be a problem was worked on. The port compressor was suppose to be run up but could not be started. The streamer was found to have loose screws in every section but only after it was nearly completely in the water and they had to bring it back in and take every connection apart to tightened the screws and retape it. This took until 2000.

We have 5 active section of streamer on board. One was damaged on the first deployment. The second one has one bad channel out of eight. The remaining three are operational. Several strategies are possible for the rest of the cruise. To reduce one streamer to a single eight channel section. This gives us two working streamers and a spare. We still have 4 weeks of surveying to do. The streamer will be left in the water for 36 hours (if nothing else happens) and brought in. After that interval all connections will be checked, if it passes this test then it will be left out for a longer period time; if not it will have to be brought in more regularly.

Due to the problems with the seismic equipment at 1900 the meeting was postponed and then held in two areas of the ship with different participants.

## **Day 248 September 4, 2008 Thursday**

-4.6 °C, foggy, light ice conditions

0630 the seismic reflection system operated continuously all night. At the safety meeting all hands were reminded the decks and outside stairs were slippery and all must use the hand rails. On the display of the seismic traces it is obvious that the second active section, the one just put in the water is significantly quieter than other one. The sonobuoy receiver or digitizer stopped working part way through the record. Ryan was able to restore it but a section of data will be lost. One goals of the day is to get the second compressor running, new diesel engines are notoriously difficult to start. Borden will also look at the suggestions John Halpenny sent for the gravity meter that is now listing to starboard, in contrast to most of the trip when it was to port.

After consultations with Jon Biggar and John Shimeld, we modified the leg of the track that runs from the Northwind Ridge to the edge of the Alpha Ridge northward to reach a 2500 m circular contour. This modification was given to the Captain and signed off. I also gave him a copy of the email that I had sent prior to survey starting notifying Fisheries and Oceans on the beginning of the seismic survey.

Shortly thereafter, Debbie and I were called to the Captain's office to discuss a problem that had just arisen on the availability of RadarSat II images that are critical

to save maneuvering of the ship and towing gear. Before the shipped sailed there was a teleconference and it was agreed that all images would be shared between vessels. The problem is that an agreement has expired. The LSSL is now outside the region covered by the Canadian system into the region covered by the US. Jacob Verhoef Head of UNCLOS has been informed and asked to contact Marie France Gautier at Canadian Ice Services, Debbie has informed the US State Department and the Captain has sent emails to the Canadian Coast Guard system. We wait on a resolution. It is foggy now and the helicopters cannot fly. This is a safety issue as outlined in the Captain's message to NRCan and CCG.

Wilfried Jokat, the chief scientist on the Polarstern sent me the position of the lines he has just run. I will return the favour.

At 1900 I gave a presentation on the role of the LSSL in extending the Canadian Polar continental shelf. I was able to use the animations that Andy Arsani gave me to show how the formulae and constraint lines work. There were lots of questions and I gave a private showing to Sherry Hudson when she came off shift. It is pleasant to have such interest in the program.

At our regular science meeting shifted by an hour Barb noted that one of our way points was positioned in seven tenths ice. Rather than damaging gear we shifted the track away from heavier ice. Borden reported the following: the port compressor was run for the first time and supplied air for 4.5 hours without problems; Peter has so far built 17-18 brackets to stabilize loose equipment in the compressor containers; the conductivity on the streamer remained at an all time low 108 all day and the new computer monitoring system for the port compressor failed after one hour due to vibrations. A new mounting place with fewer vibrations will have to be found.

John Shimeld replied to John Halpenny and has been sending him numerous files for analysis. There is no solution to the gravity meter problems in sight. The seismic profile from the Canada Basin to the Northwind Ridge and across that John has just processed displays an excellent signal to noise ratio. The higher frequencies of the 120 cu in airgun are providing excellent resolution. You can readily see a finely stratified section overlaying a section with more perturbation. In addition layers pinch out as basement rises and on the ridge there are small well defined faulted basins.

The electronics that monitor the shot indicated that the two large guns firing instants were drifting. At 2300 John was called by Dwight to assist in removing a number of log files from the computer that controls the unit. This solved the problem.

## **Day 249 September 5, 2008, Friday**

-5 °C foggy

The shot instant on the two large airguns were not stable. The seismic system was brought onto the deck at 0830 as planned for maintenance and monitoring of the streamer. Shigeto launched his XCTD just before the shipped turned to get on station so the ship had to remain on course until he had finished recording.

Barb was still concerned about the problem of getting RadarSat II images over the next few days. There is a complicated arrangement of who gets the data from which down load station. It appeared that all the images we needed would be stored on the

onboard recorder on the satellite and the most we would suffer was a 2-12 hour delay when the data were down linked to locations in Canada (in the east Gatineau and in the west Prince Albert). This problem was exacerbated by the fact the communications are worsening as we move north. She had hoped that the Healy would be with us at this point and that she could use their iridium communications systems. Critical images were acquired via MSAT and we will continue along the planned route until the ice requires modifications to the ship's track.

The safety issue of the morning was that Borden, Ryan and others were working under a tarp that covers the airguns that is heated by kerosene fuel source. Great care to ensure the tent is properly vented is being taken. They are working in pairs and the Chief Mate is monitoring the situation.

After lunch I gave my presentation on the role LSSL is playing on Canada's Arctic UNCLOS program to a second audience. Afterwards I distributed copies of the talk to the Captain, Chief Engineer and Chief Mate. The Quarter Master Stanley Fleet has requested digital and paper copies and he will receive them as well.

While the gear was on deck the connections on the streamer were checked. Those that were tightened on the last deployment were stable. Therefore we will leave the array in the water for 48 hours 12 hours longer than the last trail. The non active sections that had not had the screws snugged up were checked and if required tightened. It took about four hours to complete the cycle of bringing in the gear, repairing it, moving back on to station and streaming it again. Borden was hoping for a better turn around time but I do not want them to rush and have mistakes made. For the third time in its 700 hours of running the universal joint on the starboard compressor is being replaced. There has to be a serious misalignment in the machine that we cannot address at sea.

At supper a discussion took place with Borden and John about the gravity meter, we have decided to cage it and turn it off. When the Healy arrives in two days that ship will have two running gravity meters.

John decided that the software on the seismic acquisition system was now stable enough to install a 3Hz filter. On the plotted sections, he has removed the water column from the records and increased the gain, so that the images are more readily interpretable.

The data were to be displayed today so Debbie and I had to trim and tape the paper sections and get them laid out in the boardrooms. We can definitely see increase in basement depth across the basin from the Northwind Ridge to the Canadian Polar margin that is mirrored by the gravity data.

The data showing was attended by about 15 interested individuals during the first half hour. Individuals continued to arrive until 2130. The level of interest from the ship's company is encouraging. At 2230 John arrived with an extraordinary section that showed basement rising up from 9 to 5 seconds. We are delighted with the penetration and puzzled about the origin of the feature. Are there hints of compression? The gravity showed a deep sedimentary basin coming up so we launched another sonobuoy.

At 2330 Dwight called and said there had been another sonobuoy failure should he launch another? With several failures in a row I saw no point until the problem could be diagnosed and fixed.

### **Day 250 September 6, 2008 Saturday**

-2.2 °C, foggy, gray skies, many tenths ice with open water with nilas to grey ice

\*rewrite\*

At the safety meeting Fred mentioned the winds were making it difficult to walk along the windward side of the ship. The seismic reflection system ran well over night however the last 3 sonobuoys suffered sudden death syndrome. Is it a battery related problem?

John went over his processing sequence with Debbie and I.

Today on the compressor they have replaced three stages of the high pressure fittings. This constant repair is a bit discouraging. On the bright side I asked Jim about the time it takes to recover the streamer 7 minutes compared to last year of 17 plus the physical amount of work is reduced.

During the afternoon the winds reached 30-32 knots and the ice pack began to compact. There were no obvious leads in the direction of our way point. It was decided to pull the seismic at 1600 and steam toward the 2500 m contour collecting bathymetry data only. During the recovery of the streamer the ice began to crowd the stern and the propellers were given a kick. This caused the ice to move rapidly and it caught the streamer spoiling 100 m off the winch damaging the drum; fortunately not the streamer. Tomorrow the streamer will be removed from the drum and the winch repaired.

At the 1900 meeting Barb reported continuing poor weather conditions that are compacting the ice and creating new ice now in the grey to grey-white classification at nearly 30 cm thick. This will impact our decisions of where to work next. Jon Biggar has strong preference for a line that is just within the pack ice. Jonah and the marine mammal observer's team have seen no living creature for over 24 hours, not even tracks. They diligently stand their watches on the flying Bridge. Many of the scientific staff has commented on the high standards of alertness and punctuality they keep

The Wii bowling tournament was won by one of the officer cadets Amy. The Captain stated that no game brought on board in recent years had done as much for team spirit on the ship. It was held in the officer's lounge on the high definition wide screen television. The cooks provided three large chafing dishes of hot appetizers.

### **Day 251 September 7, 2008, Monday**

-1°C, overcast large concentrations of ice 9 to 10 tenths, snowing

At the 0745 safety meeting three items were brought up. Peter needs a fire extinguisher for his work shop and he will see the First Officer Stephane. Peter also needs familiarization with the ship's lath and the engine room staff probably Sherry Hudson will give instructions on its proper use. The decks and railings continue to be slippery.

Shigeto is now assisted by the hydrographers in the procedure for launching his XCTDs. They page him at 22 nm intervals. Then do the communications with the Bridge for him.

The technical staff had to repair the damage to the winch that reels the streamer on board. The crew lifted the drum to the hangar deck and the streamer was spooled onto the deck. The reel, which is approximately 6 feet in diameter, was placed beside Peter's container. He was busily machining parts for it. I was given a tour and got a summary of the safety precautions from \$2000.00 protection masks with \$150.00 filters that Peter had changed that morning, precision tweezers to remove metal splinters and new fire extinguisher. During my rounds of the work areas I took pictures of the large plastic signs installed in various areas such as the doors to the compressor container to wear ear protection and safety shoes.

At the 1900 meeting Barb had to be vague about weather and ice predictions because the ship no longer has MSat so she has no recent images to work with. She is predicting winds to 15 knots tomorrow improving on Tuesday and deteriorating on Wednesday. With luck the wind direction might be from the south and blow the pack ice away from the continental margin.

Borden and his technical staff managed to repair the winch and get the streamer back on the reel. The calibration phone is believed to be working. The calibration will not be done until we are in more open water due to the possibility of damaging the seismic equipment. Fred discovered today that the universal bearing on the starboard compressor takes significantly more grease than the manual suggests. This may account for the failures. The electronic monitoring of the compressor, the annunciator system is running now in its simplest form. At this stage the gauges can be read and the operator notified to call the seismic lab. Eventually it will be able to create spread sheets that include its vital statistics.

## **Day 252 September 8, 2008, Tuesday**

-1.4°C over cast visibility up to 3 nm

The bathymetric survey overnight did not cross the 2500 m contour so the line has been extended to 83°N. This has the serendipitous affect of pleasing the Captain because he wanted to get as far North as possible.

The first half of the morning was spent trying to raise the USCGC Healy by marine radio, Iridium phone and GMDSS (Global Marine Distress signal system). It is rather worrisome that no results were achieved with the emergency system.

After preparing waypoints and data file folder for Healy, Debbie and I had a tour of the engine room in preparation for our trip to the Healy to be conversant about the finer points of the ship. After putting on our ear protectors we saw the 5 diesel electric engines, the generators, compressors, shafts, and control room. The LSSL can develop 37,000 Hp but only deliver 27,000 Hp to the three shafts. When the ship is using 2 engines the consumption of fuel has been about 17 cu meters (cubes) and 25 with three engines. In drydock the two wing shafts will be inspected and the anodes in the sea bays. As well some of the bubbler piping is exposed and it is probably taking a beating from the ice.



After supper there was an emergency station drill. The scientific staff meeting point was changed to the forward lounge due to the mock causality in the hangar. We also did a boat drill. The marine mammal watchers are the individual still confused about the instructions. Jonah does not hear that well and he left his hearing aid at home. I must think of a way of keeping him informed.

All day, at regular intervals, the mates on watch tried to raise the Healy. Jacob called and tried to facilitate the exchange. Near 2200 the Captain was on the Bridge using the Iridium phone that would get cut off after perhaps 45 seconds. He tried his portable Iridium phone and eventually got information to them on our present position and the rendezvous point. Radio frequencies were established and a brief conversation took place.

## **Day 253 September 9, 2008 Tuesday**

-2.4°C winds 5 knots now from the south

At the 0745 safety meeting, at Nelson's suggestion, they were planning to weld handles on the heater called a Herman Nelson to make it easier to move. This will protect fragile backs. The compressor will have its oil changed 40 hours early so that it will not need to be stopped mid line once the Healy is escorting us. Jim is working on repairs to Peter's lath and Ryan is assisting Rodger with the oil change.

Hydrography collected 225 km of soundings yesterday and 223 km the day before. They crossed two separate 2500 m contours and along with the new Healy data from Larry's Mayer's just completed cruise should have developed a good understanding of the bathymetry of this corner of the Alpha Ridge.

Communications with the Healy improved continuously over the day. At 1130 the sky began to brighten and a helicopter ice reconnaissance was planned. The helicopter had a short flight before encountered fog banks. The ice reconnaissance revealed a large flow over the proposed meeting point. Due to the size of the flow on the leeward side of it the fog was diminished. The sounder was shut off. In the large pool of open water a small boat was launched to check the ship's draft for the hydrographers, an SVP was done and Jon tested his spot sounder over the side of the ship.

We waited for the Healy. It was in sight about 1630 and flight operations were planned for 1800. At this point the pilot Jim, the engineers Steve, the Captain Marc and USGS representative Debbie and I flew to the Healy. We made several orbits of the ship and were briefed on landing procedures before given permission to land. We were whisked away to a boardroom where the Captain and chief scientists were seated and the others on the peripheral couches. The Captains exchange information in glossy folders on their ships and hats. Weather and ice briefings were given. I went over the science plan. Jon Childs described the multibeam bathymetry they had been collecting. He requested 3 hours of time to complete a survey they could not finish from the previous cruise due to the position of a large flow that the ship could not penetrate. It was agreed to do this. I went over the changes to the seismic program. I specifically stated I wanted continuous not strait lines and 10 NM deviations were acceptable.

The nautical and scientific portions of the groups separated. The science staff traveled down step ladders to the cavernous lab spaces. We were shown the

multibeam and digital display for track data. It was most impressive. I gave them paper copies of the seismic section and sonobuoy profiles to date. My priority was to check that the waypoints I had given to Healy were accurate. It took a while but I finally found a person, Steve Roberts who could enter the new waypoints into the Healy's navigation system. Fortunately, they matched the points I had plotted.

We climbed back up the about 4 sets of steep stairs to the helicopter deck and were flown back to the LSSL. The Healy began its multibeam survey of a deep canyon. We needed to stay near by while Dale Chayes worked on the link between the Bridges. The Healy finished its multibeam survey; Dale did not complete his work but was flown back to the Healy so we could begin seismic profiling.

The technical staff and the Boatswain efficiently launched the streamer and the airgun array. Permission was asked from the marine mammal observers to fire the airgun. I was told to wait. Borden misunderstood and started firing. The Bridge immediately called back and we ceased firing and waited. After a few minutes the official okay was received and the shooting began. It took an additional 5-10 minutes to set up the data logging and display due to lost parameters in the software package. This was corrected and the data collecting began at 1216 on line 8. It is planned to cross from the edge of the Alpha Ridge to the bathymetric ridges on the Canadian margin north of Borden Island.

Borden had to struggle to get the sonobuoy 22 recording underway. The testing of the sound gearing through the port hole near the recording equipment had dislodged the memory cards in the computer. Eventually sonobuoy 22 was in the water and it had a good strong signal.

I went up to the Bridge and could not see either Healy or the track it was breaking. To begin with Healy had attempted to split a flow and became beset. The Second Mate Katherine had to swing the LSSL around her into a lead. All night the Healy tracked at least a km ahead and seemed to provide minimum ice breaking support.

## **Day 254 September 10, 2008, Wednesday**

-3°C foggy

The seismic gear ran all night without problems. Sonobuoy 22 lasted 3 hours before the noise obscured the data.

At the 0745 safety meeting, it was noted there was snow on the decks. Jim suggested that the winch man's platform on the "tween" deck should have a metal grate to replace the solid steel deck so he could see the wire below him.

On the Bridge observing the distance of the Healy our escort in front of us, it was obvious it was just too far ahead to be helping with the ice breaking. The Captain was going to have a cordial chat with Captain Sommers to see if the distance could be shortened. By about 1100 the Healy was just several ship lengths in front of us.

Kelley Brumley who just transferred on to the LSSL from the Healy summarized their multibeam work and the location of 7 successful dredges on the Chukchi Plateau and the Alpha Ridge. A range of stratified rocks, continental basement and basalts were recovered. They will be age dated in the next few months. Debbie and I described to her the seismic data and our interpretation of the Canada Basin based on this

information. We hope that discussions in the next three weeks will give us all insights into character and origin of these intriguing geological provinces.

I had a number of extra tasks to do printing out plots for John and making tracks charts for Jonah.

The seismic equipment continued to operate throughout the day. At about supper time the Bridge called asking whether we were running a great circle route or a rhomb line. Paul plotted both on the Regulus navigation system. Because the line is about 200 nm long and is defined by only two ways point the off track distances differed up to 8 nm. To clarify this problem, it was decided to create two intermediate ways points.

We had our regular science planning meeting at 1900 attended by both the Captain and the Chief Officer. Barb predicted the ice conditions would be come more difficult for the two ships to pass through. At about 2200 hours this proved to be true.

Borden's staff continues to work on the airgun sled that is onboard improving the hoses connections with the dyes they received from Healy. The third tugger winch is now configured to assist in the deploying and recovery.

At 1930 we had our first science radio communication from the LSSL Bridge to the Healy . We passed on information on data quality and thanks for the box of equipment including dyes, fairing and software that they had carried for us. Kelley had planned to get back on the ship to send an email to submit her American Geophysical Union abstract but unfortunately activities on the Healy prevented flight operations. We asked for the bathymetric data where our sounder had not detected the seabed.

It was Jim Etter's birthday so Debbie made him a card and presented it to him in the lounge at 2030. We all stayed for an hour or so to celebrate his birthday.

## **Day 255 September 11, 2008, Thursday**

-5.5°C low ceiling

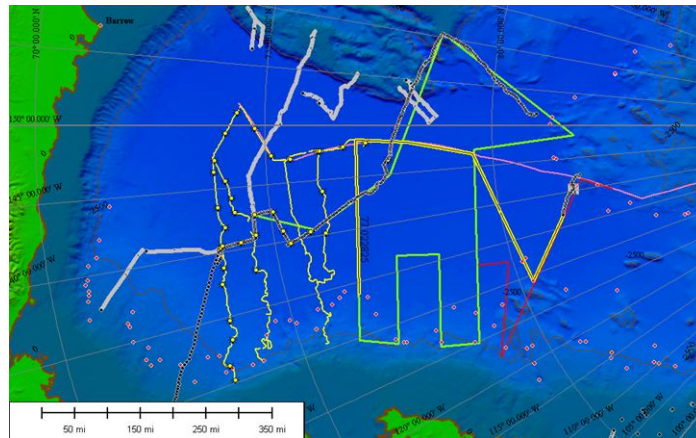
Although the LSSL was stopped several times during the night, the equipment survived. At the 0745 meeting icy decks were again a concern. I saw Officer Cadet Bennet thoroughly salting the decks. The technical staff is involved in preparing a monitoring system for the main compressor on the starboard side of the ship. The new control panel will also be of use to the engine room as they will be able to monitor fuel consumption and plan their refuelling.

Because the ice is challenging, I spent time trying to optimize our plan. Here is a copy of the note I prepared to be carried by the helicopter mechanic to Jon Childs. Jon Biggar, John Shimeld, Borden, Debbie and the Captain all vetted the concept before I put it in the envelope.

Hi Jon,

Here are my thoughts on the track over the next ten days or so. I am trying to minimize pulling the seismic equipment through ice above the foot of the slope.

See accompanying figure. The two ships travel along the yellow line towards the foot of slope and then turn towards G. The route from G through new O to N takes us along the 350 nm limit. The ships turn at N towards M. The seismic equipment is taken out of the water past the foot of slope. Now we concentrate on bathymetric measurement. The two ships separate. LSSL works in the MLJK region. Healy runs multibeam H to 4 and eastward if possible and then returns along the red jagged line to get the isolated 2500 m contours and dredges if possible. The ships meet at the foot of the slope on the GH line and we begin seismic reflection again. Perhaps running JO and OK. Is this acceptable? What do you suggest? Cheers Ruth



**Figure 2.3 Modified survey plan.**

At about 1130 the LSSL became beset in the ice. A block of ice was jammed across the track the Healy had broken for the LSSL. Increasing the engine power did not help. The Captain carefully and patiently worked the ice by controlling the engines and coordinating the effort on the Bridge. The bubbler was turned on, forcing the ship to slip back a little while keeping the propeller thrusting to keep the seismic sled away from the stern. We then had a little space but sufficient to move forward again. The ice block tumbled, moved off to the side hit a larger but thinner flow that went hurtling towards the stern. The gear survived the manoeuvre.

We have to be careful not to let the streamer plunge to 70 m as it has done when we stop. The Healy must stop for helicopter operations and the daily exchanges between the ships are increasing. Discussions with the Captain solved the problem by keeping the ship slowly creeping forward and asking the Healy to move well forward before pausing for the helicopter operations. This allows space for LSSL to move forward enough to protect the streamer.

I had lunch with the Mate Zach from the Healy visiting the LSSL for the day. During our conversation I realized he did not understand some of our concerns with the gear. He thought it took hours to take it out of the water. He did not know we had two complete sets and could not readily visualize the airguns. Borden gave him a thorough tour and perhaps this will help with operations. Furthermore, the pictures of the LSSL's company newly organized and labeled by Kelley Brumley were given to Zach to take back to the Healy.

I met Lorne, the ship's electronic technician, looking particularly pleased. He just learned the Healy's radar was refusing to plot the track like just as ours were. The error message was incorrect latitude. He now realizes the radar software does not work properly above 78°N.

Debbie was intently tracing horizons on the seismic sections. She has found that the upper well-stratified layers abut the Northwind Ridge, but in the lower more disturbed zone the layers terminate against the scarp, suggesting a significant event occurring at that point. We are collecting hard facts to control our tectonic reconstruction of the region and this is another data point that any model must explain.

At 1900, John Shimeld gave a PowerPoint presentation on the seismic reflection system and processing entitled "What goes bump in the Night." It was beautifully illustrated and clearly explained.

As the day wore on, we continued to be trapped by the ice for longer periods. At the 1930 science meeting Barb reported that ice conditions were consolidated ahead 10/10 with no leads and under medium pressure. There was no choice but to continue because of the need to get bathymetric data in this region in hopes of reducing the needs for expensive and difficult ice camps. The science staff at the meeting was unanimous in their opinion that we needed to continue.

We spend about two hours caught in a narrow portion of the Healy track and the US Coast Guard ship had to swing in a circle around us and then cut in front to free us. We carried on for another several hours alternating the Healy or the LSSL having problems with the ice. The seismic reflection was noisy to unreadable. At one point the Captain had to put the centre shaft on and give it full power. Borden was notified and he agreed it had to be done. At about 2300 the decision to bring the seismic gear on board in spite of the risks was taken.

With a mere 30 metre-long stretch of open water behind the ship, the airgun sled and streamer were brought in. The bundle cable had four to five loops in it from being tumbled by ice blocks. There were damage clamps but nothing serious. The streamer came aboard in less than 10 minutes also without problems and no apparent damage. Considering we had been towing in up to 10/10 ice under pressure this is truly remarkable. A careful inspection of the equipment will be performed in the morning. Jon Biggar produced a new way point (80° 07.5N 127° 58.4 W) to cross the 2500 m bathymetric contour and this was given to the Bridge. The ship had to use 5 engines and full power to free itself. The ship positioned itself near by Healy and waited for a CTD to be completed.

## **Day 255 September 12, 2008**

-5.5 °C clear skies, 10/10 ice

There was a selection of fresh fruit on this morning because the Chief Cook on visiting the Healy had been offered it. It was truly appreciated.

Notes from the 0745 safety meeting:

- All were reminded the snow on the decks was making them slippery again.
- Fred had spent the night preparing the compressor for use again.
- Ryan was assigned to over hauling the sled that had just been brought in.

- Borden is actively working on the cruise report.
- John Shimeld had to prepare his PowerPoint presentation in a form useful for the Captain.
- Debbie left for the Healy for the day to give a presentation on the airgun system to clarify to the Healy's company what we were doing.

Jon Biggar was preparing for spot soundings while the helicopter was making two trips to the Healy this morning. Borden needs a half day when the helicopter is not flying to work on the twisted clamps on the towing bundle. The Captain suggested coordinating this with the 100 hour maintenance schedule on the M105 helicopter.

On arrival at the Healy, Debbie and Jon discussed the possibility of the LSSL breaking ice in front of the Healy to improve the quality of the multibeam. They called to discuss the possibility. I had made that suggestion when I was on the Healy but had been told it was unlikely to work. I readily agreed to try it and the data quality immediately improved. At this point when the LSSL took the lead there was 10/10 of ice. The ride on the LSSL has become rough since we took the lead. It took until mid afternoon to reach 2200m and be sure we had the foot of the slope. The seismic reflection profile is 277 km long but at this stage I have no idea if there is sufficient usable data.

Dale Chayes flew over to the LSSL to get the communications link set up. The data on the real-time link between the ships was especially useful for the distribution of the ice information.

The ice was 10/10 in medium to moderate pressure and the ship was pinched when the Third Officer Neil came on watch. For a couple of hours he tried powering his way out of the situation looking more discouraged as time went by. The Captain called on the Healy for support. The ship advanced slowly in the fog asking LSSL for more lights. It paused several ship lengths behind us and fell back. The ice had been altered slightly. The Wartsila air bubbler system was running and the ship started to slip backwards.

The ships began to work together side by side at perhaps 500 m distance. One ship advanced and rammed while the other ship backed off, giving the ice a place to move and releasing pressure. The comradery on the Bridges between the ships was obvious. The Healy hit a particular large pressure ridge that lifted her bow well out of the water and brought her to a sudden stop. The officer quipped that rattled the filings out of his teeth. For several hours the two ships struggled neck and neck. Eventually the LSSL was able to move forward so that Healy's multibeam could be of better quality. This episode of ice breaking was a powerful example of the advantages of cooperation.

John Shimeld plotted out the seismic reflection data from Line 8 from the Alpha Ridge towards the Canadian continental margin. Despite the deplorable conditions for collecting seismic data at the end of the line, with the streamer perhaps hanging nearly vertical, and the noise on the streamer, the data are of good quality. It is easy to follow basement at a depth of two seconds. The foot of slope plus 60 nm and foot of slope plus sediment thickness overlap here. This observation significantly reduces the work that will be required in this area from ice camps. This information will save millions of dollars and significant time if isolated 2500 contours are acceptable to the Commission on the Limits of the Continental Shelf (CLCS).

Sleeping was not easy with the erratic motion of the ship. It shudders, shakes, and the ice scrapes noisily past the hull. In comparison, the seismic operation is rather quiet and peaceful.

## **Day 257 September 13, 2008, Saturday**

-13.7°C fog

The ship ploughed 20 NM through 10/10 ice last night. It is still a considerable distance to the edge of the Canadian ice pack.

It is significantly colder and the decks are icy. The technical staff was given this information before starting work for the day. The starboard compressor will be run up today to ensure that the repairs to it last night were successful. Air lines and bottles will be blown out to hopefully remove ice. Work continues on repairing the damaged bundles. Borden is trying to find a way to keep the clamps from slipping.

After breakfast, the ice conditions improved and the speed of the LSSL increased. Without satellite imagery or helicopter reconnaissance flights, it is difficult to judge how much farther we need to go before putting the guns in the water and which direction would be optimal.

At 1100 a significant lead was encountered and all station work including SVP and CTD's from both ships were run that would be required for the next few days. By 1630 the three airguns were firing and the logger acquiring data. The depth sensors are not working on the streamer unfortunately. An expendable sonobuoy was put in the water but no signal was recorded. Borden and Ryan dismantled the receiver and discovered it had been destroyed high energy radio bursts. The helicopter radio beacon is too strong for the electronics. We will have to turn off the system during helicopter operations.

Just after starting the airguns a bear and a cub were sighted by the marine mammal observers on Healy. They were sighted soon by Jonah who had to repeatedly point them out to the rest of us who could not see them at 2.5 nm. The Bridge was lined with volunteer observers. The closest approach of the ship to the bears was over 1 km so it was not necessary to turn the airguns off.

At 1900 during our regular science meeting the ship began circling and the Healy appeared to be stopped. We learned that the lead was blocked by heavy ice and either the route had to be changed or the gear brought back on deck. The helicopter was sent to do an ice reconnaissance and determine the best way through the ice.

The data display in the seismic laboratory shows the traces especially the first eight traces are noisy. I will have to wait until morning to decide whether the data quality is adequate. Pulling the gear would be difficult as the lead has closed and the ice is under compression. The Healy track closes in behind it.

Dale Chayes has opted to stay aboard for the second night to continue to work on communications link between the ships. Tonight should be better for sleeping since we are not the lead icebreaker in heavy ice. The guns stopped firing after I went to bed. I called the lab, Dwight explained a seal had been seen and the guns would be operational when we were 1 km from it.

## **Day 272 September 14, 2008, Sunday**

-6.7°C overcast, 9/10 ice mostly first year

No safety issues were brought up at the 0745 meeting of the technical group. The compressors oil and air leaks seemed to be stable.

John Shimeld was having problems finding the data files for latest sonobuoys. He sorted the problem out in conversations with Jim, Ryan, and Borden. When Debbie plotted the sonobuoys she noted they were all misplaced in location by 6 hours. The computer on the sonobuoy logger has to be reset to UTC. This has been corrected as well.

The mist lifted today enough to allow for a short flight to the Healy. The plan was for Barb to fly to the Healy to get a RadarSat image, Shigeto the oceanographer to discuss water sampling and Dale Ruben to meet the Healy's marine mammal observers. All were prepared to spend the night. Dale can do his watch from the Healy if required. The flights did not occur. Dale Chayes was able to get one RadarSat image over the wireless network he had set up so Barb had some information to work with

The data quality on this seismic reflection line is the poorest we have observed in two years. I correlated one set of noise with the ship being beset in the ice and released by the Healy but the rest is now unexplainable. Borden will pull the sled after lunch and check for any problems and I will talk to the Chief Engineer about any engine changes he has made.

The sled was pulled from the water after lunch and the towing point changed. The hose clamps were checked and firing lines inspected. The sled was back in the water within twenty minutes. The ship's speed had been dropped to two knots. It took a while to get the ship back up to 3.5 knots because the port shaft had a short and had to be reset by the engineering staff. The data quality was significantly improved. However the solenoid on one of the guns froze up and it took several hours to get the situation corrected by pumping anti freeze into the airguns.

It's Sunday and the special meal has been put on. The science guests are Peter, John Shimeld, John Ruben and Fred Oliff. Dale Chayes also received an invitation to dine.

By supper the seismic system started to be noisy again. It is possible the port sled does not tow as well as the starboard. In the morning I would like to change sleds. At 1800 Borden launched a sonobuoy. Care must be taken to turn off the receiver when helicopter operations are taken place to prevent more high power radio frequency damage.

Because the email on the ship is not working, I made several calls on the iridium phone and left a message for Dick MacDougall that summarized the weekly report. I will try and use the Healy email tomorrow.

John played the seismic section back before bed time and it was not as noisy as it appears on the screen but it is certainly not our best quality data.

## **Day 259 September 15, 2008, Monday**



-2°C perhaps 8/10 with about a third of it nilas to grey ice, also some rare snow ball ice

The 0745 safety meeting took place beginning with a reminder that there was snow on the upper decks. The fourth stage high pressure piping on the starboard compressor has vibrations in it and consideration is being given on how to dampen them. The seismic reflection system operated all night with all guns firing, the data from the airguns on the port sled still appears to be noisier than the starboard sled. The chief engineer prepared a list for us on the main engine and propulsion configuration so that it can be compared with noise on the seismic reflection system. There was a plan to reassemble a streamer with a depth sensor that works but that was aborted due to uncertainties about which of the 6 sections had been tested, used and rejected.

I had Dale send the weekly message to Dick and Jacob over the Healy's email system. Dale got a reply from Dick so it reached its destination. Several hours later our shipnet email returned.

We are about 10 hours from the end of seismic line 9 at point G in the centre of the basin. The ship will then turn towards the Canadian margin and into heavier ice. Barb has asked for a flight over the margin and along G to H. The Healy multibeam team would like to move away from the LSSL to a more exciting bathymetric area. Debbie has promised to think about it.

Dale Ruben took the opportunity to fly to the Healy at 0930. He is prepared to stay over night and do his marine mammal observation from the Healy if weather conditions do not allow him to return.

The Bridge was given the position of three points along the great circle route from G to H called GH1 to GH3. At G the ship will stop to retrieve the sled and replace it with the starboard sled. The Healy will stop before we turn to do water sampling. They will come back into the lead after we finish switching sleds.

Kelley is working on her doctoral thesis proposal. This makes for lively discussions about the significance of the seismic profiles, gravity and magnetic data. She has had several opportunities to refine her models lately as the new seismic reflection profiles give insights into the sedimentary and crustal structures in the region. The synergy between the bathymetric-sampling programs and the seismic-potential field program I hope will prove a significant step forward in understanding the Canada Basin. I wonder if we should have a session at a conference on the results of the Healy swath bathymetric cruise to the Chukchi-Alpha Ridge and the joint Canada Basin expedition. Of course it would be interesting to expand to include the Polarstern data on the Mendeleev Ridge.

The ice concentrations continued to dwindle as we approached the end point of the line near 139°W. Dale, the quartermaster, described the pattern the LSSL makes behind the Healy. The Healy draws a curve pattern through the ice and the LSSL makes a straight line. He said he was making dollar signs all day long.

Today I gave another presentation on the UNCLOS program to Andre the fourth officer who had missed it previously. He seemed pleased that he now understood why we were collecting the seismic data.

The regular science meeting was held at 1900 and this was followed with our 1930 conference call to the Healy. The voip link now has a range of 2.8 nm. We were able to tell them about our plans for the evening. Dale Chayes is still onboard working on improving it.

The thickness of sedimentary section reached a maximum of only two seconds in this region. The mystery of whether there is one seismic streamer with an operating depth sensor is still being investigated. It is unclear whether it was the electronic package in front of the active section or the active section that was damaged.

At 1745 the ship was stopped a few kilometres short of the end of the line in order for the engine room to oil the bearings on the shafts. This was to take an hour or more. As the ice was light, the Healy had already stopped to do water sampling and a CTD cast. It was about 2345 before we were on line again. The airgun array and streamer were retrieved without damage. The starboard sled was to be put in the water in place of the port sled. The compressors had routine maintenance done to them. The kellam grip was moved back along with the repeater module to ensure nothing would be rubbing against the sled.

An airgun calibration was attempted for the fourth time in three years. Nine different combinations of the airguns were recorded with the hydrophone at depths of 400 and 200 ft. The signature of all the guns: individually, in group of two and all three were also captured digitally.

## **Day 260 September 16, 2008, Tuesday**

-1.1°C low ceiling

At the 0745 safety meeting the state of the compressors was reviewed, as it is every morning. Detailed and careful maintenance of them is an important aspect of our safety culture. There has been a steady leak of air and oil.

The seismic reflection data was exceedingly quiet i.e. the signal high and the noise low all night except when Healy was beset in the ice. Was this good quality data due to the shafts being oiled or the modifications to the tow sled or a combination of both?

The quality of the seismic profiles continued to be high all day. The ice conditions were light with a significant portion of open waters. The Healy seemed to be steering a particularly erratic track and it was eventually relayed that they were testing the power of their engines in larger flows.

Dale Chayes gave an excellent PowerPoint presentation on the installation of multibeam on ships. It described the management and technical stages as well as the specifics of their installation on a number of well known research vessels. The Captain, Chief Mate, Chief Engineer, Senior Electrician and Jon Biggar attended. A PowerPoint presentation will be distributed to all before Dale leave the ship. More discussions will take place between Dale and the engineering staff.

At the 1900 meeting John reported on the results of the airgun calibration. He took the best ten shots and stacked them. The shots signatures were stable. The addition of the 150 cu in gun provides more power at the higher frequencies and at the 60Hz notch. Line 10 under way now is the cleanest record collected so far.

The marine mammal watchers continue their vigilance but see little wild life. Today there was only an unidentified bird.

Dale Chayes reported that the radio link between the ships is stable at ranges up to 2.5 nm. We have been using it regularly. At the 2000 telephone call to Healy they noted (Jon Childs, Captain Sommers, Steve) that at waypoint GH3 there is a significant ice flow they would like to navigate around by sailing to the south. We all agreed this is an appropriate route alteration. It is noteworthy that prior to sailing we thought the LSSL would have ice imagery but the Healy would not. The case is reversed due their better ability to download data from satellites. Next year if they move further north the problem will be even worse.

### **Day 261 September 17, 2008 Tuesday**

low, -2°C numerous large leads at breakfast, a large flow to circumnavigate later in the day

The seismic reflection system continues to record with an excellent signal-to-noise ratio. The sonobuoy that was launched last night had a long recording window. The only health and safety issues for the technical staff related to having sufficient absorbent materials in case of spilling oil or grease on the decks or in the labs. Peter retrieved a huge bag of the material from the ships store for ease of use when required.

During the day the profiling went well with excellent data quality. John Shimeld had an extremely successful day processing the data. On each shot gather at the sea bottom it is possible to see and digitize the 3-4 meter slope on the streamer. He then developed an empirical formula related to streamer depth. Once he has determined the streamer depth he applied a minimum phase deconvolution and designature trace by trace. This removes the receiver ghost frequency notch at 37 Hz. This produces a bandwidth of 3 to 70Hz. The second frequency notch at 67 Hz cannot be removed. Restoring the frequencies significantly improves the data resolution. For instance, at 8 seconds the section is clearly faulted, a fact that was not previously discernible.

Just as the 1900 science planning meeting started, Borden received a call from the seismic lab that the streamer had failed. There was a concern that it was actually lost. It took over half an hour to get the tow sled on board and to see the streamer was still attached. The streamer itself does not appear to be damaged; the source of the problem may be the repeater. This will be determined later. The second sled and streamer were put in the water and we were acquiring data again at 2030.

The towing conditions are difficult with ice under moderate pressure.

### **Day 262 September 18, 2008 Thursday**

-2.2°C 10/10 ice under moderate pressure, cloud ceiling about 700-900 ft higher than usual

The ship was beset in ice at about 0430 in the morning and the Captain called. The ship was able to move forward several times and then the Healy had to break us out. Shortly thereafter our streamer failed. The technical and science staff was roused from bed and the equipment brought on board. The first sections of the streamer,

the stretch and vibration portions, are damaged. There are replacement parts for them. However in the last 10 hours there has been damage to both streamers. It is still 50 km to the foot of slope based on the IBCAO chart but I made the decision to stop the seismic profiling on this line to protect the equipment for the rest of the survey. The ships will change leads. The personnel on the Healy Bridge were glad to be relieved from the noise and shaking of being the lead ship.

At the 0745 pre-meeting held at the breakfast table with Borden, he mentioned that several of his team had colds. We agree that it was better to let them sleep for the morning and begin work in the afternoon. The hangar would be needed to work on the damaged streamer cables. This needed to be coordinated with the helicopter operations for the day. The weather looks more promising than it has been for days for flying.

Dale Chayes went back to his home ship and was replaced by Steve Roberts who was given a safety orientation by the first officer. Brian Dupay also flew over for the day. The Captain, Debbie, Jim (the pilot), Brian, Debbie, and I had a pleasant after lunch chat in my cabin about many benefits of two ship expeditions.

During the day, the LSSL was in the lead and the Healy was collecting valuable multibeam data. After supper the floe size seemed to increase and the LSSL was caught in the ice. The Healy was called up to assist us. After she released the pressure we went zipping forward. I was still worried that we would make the 60 NM miles to the 2500 m contour. Jon was leaving to do spot soundings, so I went to the helicopter to ask him to consider spot soundings at the end of the line. He returned with the information that their leads ahead and to the south.

Kelley and I discussed the gravity and magnetic signature of the three bathymetric highs. The curved magnetics she plotted confirmed our idea that this is the third major volcano along the Canadian polar margin. We exchanged papers to read. I also found in Chris Harrison's paper a summary of the unconformities in the Sverdrup Basin and their probably prerift, synrift and post rift relationships.

The technical support staff has refurbished the starboard streamer. It is ready to be used. The starboard streamer was disassembled and each section checked. The float cable was damaged and the last spare substituted. The tow bundle had a damaged electrical line and it would be a lot of work to take it apart and rebuilt it. It was discovered after supper that a repeater had water in it. The repeater was cleaned up and the bundle is ready to go. We have two working streamers but no spares at this point. The compressor had routine maintenance done on it. It was not run-up but the will be done tomorrow.

Jonah reported he saw a bear. Since we were not running the airguns it was not disruptive of our operations. Shigeto has launched a total of 46 XCTD's. We are now back in the water mass with low temperatures in the upper 180m. He is tracking the cold water mass. Last night he gave us all crests with polar feet from his organization JAMSTEC.

Debbie gave a presentation on the US UNCLOS program. The Captain, Chief Engineer and Chief Officer as well as the scientific staff and the cadets attended. It included the extent of their 200 NM limit, the fact that their coast lines were receding and that early submission would be advantageous to them. It addresses why the US has not

ratified because there is a perception that the treaty limits US sovereignty. It clearly showed the overlapping claim of the US and Canada in the Arctic as well.

Paul has prepared a number of waypoints for the Bridge that I checked in Global Mapper. The new waypoints were mentioned in daily intentions. Because Debbie was giving her talk, the science meeting was early and Barb felt hurt she was not properly informed.

Jon Childs at 2030 asked that the scientific staff on Healy could take a water sample at the end of line. I passed this information on to the Captain who added to his night orders.

### **Day 263 September 19, 2008 Friday**

-4.6°C strips of blue shy visible, multiyear and first years ice in concentrations of 9/10

At 0500 I received a call from the Bridge that the end of line had been reached but not the 2500m contour. I asked them to continue. At 0600 the second call came that the bottom had stabilized at 2550. I asked them to call Jon Biggar. He decided to end south of where we should cross the contour interval. At 0700 the Captain called to ensure that we did not want to continue eastward. At 0800 the ship stopped for a 100 m depth water sample.

Issues brought up at the 0800 the safety meeting with the technicians:

- Peter Vass is cleaning up his work shop and Rodger is running up the compressor that was repaired yesterday.
- Ryan continues to suffer from his cold even though he was given the morning off yesterday.

Debbie received an email from Dick to me about ship time on the LSSL next year. It suggested moving the ship time back a week. The darkness and freeze-up argues strongly against this plan. The July to August window would be consistent with joint use of Healy before it goes in to refit. An additional bonus would be that we would get to work with Captain Rothwell and his crew. The two ship Captains and crew have worked in harmony and it would be ashamed to change this well-oiled machine.

John Shimeld is worried that all the shaking the ship is receiving during breaking ice may cause a hard drive failure. I took his worry to heart and backed up the critical files on this computer. The UPS from the gravity meter that was shut off was made available to protect the computer he is using for data processing.

I spent the day studying the potential field signature of probable volcanic edifice off Prince Patrick Island. The time frame for the deposition of the Isachsen Formation is from Hauterivian through Barremian to Aptian 130 Ma – 125 Ma. This is the formation Chris Harrison associates with the rift phase in the Arctic Ocean. The Mesozoic faulting on Prince Patrick Island is lineated towards the volcanic edifice. This direction is also parallel to the gravity low in the Beaufort Sea. The Christopher Formation is Albian in age 112 – 100 Ma and is assigned to the post rift phase. The age range of volcanics or High Arctic Large Igneous Province (HALIP) is 135- 90Ma. Furthermore, the magnetic signature of the basement high is a negative. This is interesting because from 125-to 85 Ma there is a single magnetic Chron and it is positive.

All day long the ship was halted because there were flight operations, CTD's, water sampling. From breakfast to after supper the ships moved a total of 12 NM. The helicopter must have its 100-hour maintenance schedule on Sunday. This will take several days and stop the shuttling of personnel that is interfering with the program.

At the 1900 meeting, the Captain handed out his intentions for the final days of the voyage. With 6 working days left, the activities must concentrate on seismics and bathymetry. Shigeto took the news well and has come up with another strategy. He will ask the Bridge to call him when there is open water and will deploy his XCTD's on that basis.

Jonah reported he saw three sets of tracks of a bear and cub that were at least a day old. Borden and his team have checked the streamer section they thought was defective and have determined it is operational. Both sleds are ready to go into the water. The compressor monitoring scheme now shows RPMS in the seismic lab.

Steve Roberts, Dale Chayes replacement, had a new antenna installed that is not working. He is trying to get a communication system that will operate affectively between the ships if not this year at least next.

## **Day 264 September 20, 2008, Saturday**

-11°C many tenths of ice

Dave Sisco dropped into the seismic lab in the morning to explain he had carefully salted the decks. With the lower temperatures and higher winds the marine mammal observers are coming onto the Bridge to get warmed up more often.

All night long the ship made slow progress. The ship was beset several times and the Healy was required to release the LSSL. By breakfast the LSSL had finally made it to the start of the east-to-west line. Ice conditions are not expected to improve for many NM.

Tonight is pub night and to relieve the steward department, two volunteers were required to serve the meals. Debbie, Kelley and Peter volunteered. They will have to be in the kitchen at 1615 to get their hats, gloves and aprons.

I talked to the Chief Engineer, Mark Cusack, about ice breaking research ships. He thought an additional 10,000 hp would prevent us from being stopped in many of the situations this year. Furthermore his experience with the Russian ice breaker Yamal (75,000 hp) suggested to him to operate successfully in the midst of the Canadian polar pack ice perhaps 100,000 hp is required. This amount of power is especially needed if there is any glacial ice. This strong old fresh water ice requires more hull strength as well.

The logo for the cruise initiated by Brian and refined by Debbie, is ready for turning into stickers. The last biography has been submitted and will be printed for distribution. Having written this Fred Oliff decided he would rewrite his and Jon's on a style that matched the others.

At the 1900 meeting, John Shimeld described the improvement the streamer static's made in the record sections. The streamer has a considerable difference in depth

from the front to the back and it can be in the extreme, tens of meters. Next year he would like to have more depth sensors between the sections. He was concerned that there was a problem in the software when the shot numbers reached 100,000. He tested for this and found the program dealt with it.

To date, Shigeto had launched 53 XCTD's and Jonah saw only a little brown bird today. Jon tried spot soundings but was hampered by lack of open water. There will be no spot soundings for several days because the helicopter is having its 100-hour maintenance routine.

The ship had to work its way by several large ice flows and wait for the Healy. The Healy was traveling at 5 knots, the optimum speed for high quality swath bathymetry. Between jogging around the flows and the low speed it took until 1915 for the two ships to reach the proposed launch site of the airguns and streamer.

Streaming the equipment took 4 hours. The hydrophone array would not send data to the recording system. Repeaters were changed and the system carefully checked. The sled was brought back on deck and the ship returned to its initial deployment position. We have very few undamaged sections for the eel after the beating the equipment has taken pulling through ice under pressure. The three guns fired when put back into the water after heating on the deck but the solenoid on one of the 520 in<sup>3</sup> guns was not operating; the antifreeze was not reaching the gun. So Jim had to be roused from bed to adjust the injector. This effort eventually recovered the solenoid. The streamer has a high leakage number of 1300 and the monitor shows both high frequency and a low frequency noise that was not observable on previous data. John played back 10 minutes of data and basement was visible. We will just have to continue with the system as it is for the night. We have few things we can change and the crew was getting progressively colder as they stood around on the quarterdeck waiting to assist.

## **Day 265 September 21, 2008 Sunday**

-7.7°C moderate ice conditions no pressure the Healy in the lead

The seismic reflection system operated all night. In the morning, Borden discussed with Jim a safer way of bleeding the antifreeze from the high pressure system. The discussion lead to a plan and it was implemented today.

Just before lunch the streamer failed. It was brought on board and disassembled. A leaking vibration section was removed and all other sections carefully checked. In the meantime, the Danish echo sounder was checked and an SVP done. It took until 1530 to complete these operations. Then the ship had to get back on track to overlap the line. The streamer and airguns went in to the water and fired; however, there was a blockage in the air lines. Ice had formed at one of the elbows in the lines from the compressor to the bottles it took perhaps an hour to find the problem.

The crew went off to have Sunday supper but the technical staff worked through it. Except those who were invited to the special Sunday supper. Today there were six from our extended group from the LSSL science staff: Dwight, Kelley, Nelson, and Rodger and from Healy, Kevin and Steve. There will not be a final Sunday supper because the kitchen staff has to prepare for crew change. So this was the last opportunity to attend. Kevin borrowed a white shirt from the Captain and pants from another member of the LSSL crew.

Unfortunately, at 1830 one of the high pressure air lines to the guns failed. Initially we thought we would have to bring in the sled. It was determined it was the 150 cu in airgun that had the leak. It was shut off and we continued along the seismic line. It was a rather tiring day.

At the 1900 meeting Barb reported the temperatures were stable but winds were increasing and the ice pack would be tightening up again. We were stopped at 2030 while the Healy backed and ramped at a pressure ridge. It took three attempts to get through it.

John Shimeld presented the finished processing on line 5 across the Canada Basin to the Northwind Rise. The resolution is vastly improved the reflectors and basement have sharp reflections that will be easily identified and traced.

Kelley reported that she had been reading about Alaskan Geology. The references clearly identified two distinct pulses of tectonics one at 131 Ma and the other 90 Ma for the development of the Brooks Range. These are the same dates that show up again and again for volcanics in the High Arctic Large Igneous Province. The mechanisms that drive the compression of the Brooks Range should be examined for the development of the Canada Basin.

Two polar bears were sighted today by John Ruben. They were at distances of greater than two miles from the ship so did not require shutting down the airguns. Shigeto did two more XCTD's for a total of 55. We are at the transition from cold saline water to warm fresh waters.

When the daily intentions were distributed, I took the opportunity to I talked to the Captain about the timing of the refueling. He and the Chief Engineer are of the opinion that LSSL does not require immediate refueling and it would be possible to make a request to Central and Arctic Region for a changed date for this task. I will call Dick MacDougall tomorrow morning.

## **Day 266 September 22, 2008 Monday**

-8°C spectacular sunrise over significant amounts of new ice

At 0330 in the morning, Borden called me to let me know the streamer had failed. We decided to wait until morning to pull the equipment on board and the ship was sent on a large circle. At 0700 the seismic equipment was brought on board. There was a bit of confusion because Borden thought the time was 0800 for pulling the gear. However, we managed well enough under the circumstances and the equipment was brought safely on deck. The Captain called down and asked for our plan. We said we would not need the engines for at least three hours. I had breakfast with the helicopter mechanic and the 100 hour inspection is still ongoing so we will not need to stop flight operations.

There was a safety concern that one individual forgot to wear his emergency locator beacon around his neck during the recovery. This was brought to their attention. On the bright side I noticed the large sign beside the air bottles that ear protection must be worn when operating them.



Debbie and I had a look at the data collected overnight and were astounded to see two large grabens with a throw of up to 2 seconds 280 km from the 1000m contour interval in water depths over 3000m. Their direction can be determined by tracing them across our profiles and by the characteristic gravity lows. Like the onshore gravity lows on the Jura-Cretaceous Basins of Prince Patrick Island they are aligned to the east of north. Kelley was also excited to see them because it fit with her largely continental origin for the basin with mostly rifting and little oceanic crust. Debbie and I cut and taped line 11 together as well as the more highly processed data from line 1 to 5. The basement next to the Northwind Ridge to the gravity low is a consistent plane of sharp reflections that contrasts with the more undulating surface to basemen east of the gravity low.

With both ships waiting for the repairs to the streamer to be completed, I went to see Borden about his progress. I had promised him two hours of uninterrupted work. When I found him he said they had a complete working streamer. The vibration section had been bad and replaced. The airguns were being swapped and after they were heated up sufficiently they would be ready to stream the gear. The planned launch time was after lunch.

With this good news in hand, I called Dick MacDougall and asked for an extension of our working time. He thought it would be difficult. I was hoping they could move the refueling date or lessen the time it would take by firming up the refueling appointment. He was not too positive about the prospects but said he would try. In particular the long refueling time means the Healy will be without LSSL escort for several days and we will miss the opportunity to collect valuable multibeam data.

I went to the Captain with the time of the launch and the fact I had contacted Dick about refueling. I was surprised that he had already sent an email to Jamie Forsythe suggesting that this could happen. About an hour later I received a call from Dick asking for the date the Healy had to return to Barrow.

After lunch the ship had to return to the point the streamer had failed at 0300 last night. The streamer and guns were put in the water. Just as the guns hit the water an air leak developed. The guns were brought back on deck. The hose had broken at the base of the towing bundle where it connects to the sled. It took about 20 minutes to repair this. I heard comments that the gear was deteriorating and I replied confidently it was a minor problem. The gear went into the water. The three guns fired and we were collecting seismic reflection data again.

At the 1900 meeting that was well attended by the Captain, Mate and most of the science staff not on watch, we began with a weather and ice briefing from Kevin (normally on the Healy). It was well done. The ice is steadily getting thicker and the flows consolidating. Barb had chosen a route around the bigger flows and given the position to Healy to navigate around. The information was based on RadarSat II and a reconnaissance flight. The helicopter has completed its 100 hour inspection.

No marine mammals today, one more XCTD for a total of 54 and Jon Biggar had a spot sounding mission in the helicopter. We all hope the airguns fire all night. A lovely sunset took place tonight to complement the sun rise both lasted for about 3 hours.

## **Day 267 September 23, 2008 Tuesday**

- 8.8°C ice concentration and thicknesses increased overnight

The seismic system ran successfully over night. Although many of the staff would like to see the LSSL closer to the Healy to protect the gear, a closer distance has its problems as well. If the Healy has to stop to back and ram, the LSSL must also stop. As soon as the ship stops in these conditions the ice adheres to the hull and a lot of thrust is required to free the ship also putting the streamer at risk.

The safety meeting was brief with all the equipment working.

Jon Childs the Chief Scientists on the Healy flew over with the Captain Fred Sommers and two other heads of departments from the Healy. Jon toured the seismic lab and then had a chance to review the reflection and sonobuoys collected since we visited the Healy when the ships met.

We met with the entire party in the lounge at 1130 and from there we had a five course lunch. At this point I tried calling Dick who replied that LSSL could refuel at a later date in the eastern Arctic. Thus we would have more time to continue bathymetric measurements with the two ships. Later in the day we got a different message through the ship's contact. I am totally baffled. So I have decided on prudence and to shorten the seismic line to be in a position close to the foot of slope on Thursday at 1630 when the ships raft together for a barbecue. From this point I hope there will be 24 to 26 hours to get the last two fouts of slope necessary along this segment of the margin.

Jon Childs wanted to know when he would receive the cruise report and seismic reflection SEGY files. He was surprised to learn he would receive the processed data by the end of the cruise. John Shimeld will deliver all the raw and processed data to Debbie as he leaves the ship. He will get everything up to the point where the Healy leaves us. We also discussed the cruise report will be exchanged six weeks after the cruise. Where the seismic sections are in the cruise report or a separate confidential report will be decided by Jacob Verhoef.

We hope to have an EOS article (magazine of the American Geophysical Union) and a Nature paper about the origin of the Canada Basin as our first publications. The complete data set will be published as a multi chapter issue of a journal such as Canadian Journal of Earth Sciences. We prepared a list a list of possible submissions. Before we had run out of topics to discuss the call came for the guests from the Healy to get on the helicopter for the return flight.

After our meeting I went to the Bridge and shortened our proposed track toward the 350 NM limit. The highest priority for this trip is to work close to the margin in difficult ice conditions. We have 48 hours left before the seismic equipment must be brought on board.

At the 1900 meeting Barb reported that the weather should be dominated by the polar high for the next few days. Temperatures will be in the range of -8 to -9°C. The shortened track is through ice conditions that should be readily passable with both ships. Borden reported that all the seismic equipment is operating. Shigeto has done 2 more XCTD's for a total of 59. Steve Roberts has put together the Knudsen profiling data along lines 8 to 11. These composite profiles clearly illustrate the foot of slope. Steve said they could be plotted on the large plotter on the Healy and picked up when the ships are rafted together. This will be a good display for Dick and Jacob.

## **Day 268 September 24, 2008 Wednesday**

-9°C significant portion of grey ice perhaps 50% with small flows

The ship had problems with power last night and was stopped for three hours until it could be restored. In the morning the problem was addressed but it took another three hours with the ship not moving. This brought to our attention the fact that the seismic lab does not have emergency lighting. This will have to be dealt with before the next field program

The Captain called me to the Bridge to tell me the refueling date has been moved to a slightly later date. Thus we will be able to continue working until 1500 on September 27. The ships barbecue was planned for Thursday with the ships tying up at 1500 hours. Because the king crab legs will be thawed, this will occur at the scheduled time. Our present plan is to stop the seismic reflection acquisition at the time the ships raft together. The bathymetric program will resume for the night and in the morning the three large airguns will be calibrated.

During the day we were caught in the ice twice, once around 1430 and the second time about 1915. The Healy readily broke us free. Just before we pull the airguns for the final time (hopefully tomorrow at 1330) we are trying to keep the system operational as long as possible. It may have been possible to free the LSSL with additional engines. Ice conditions are getting more difficult as we head towards the continental margin again. The amount of newly formed ice is increasing and there is pressure on the ice. The track of the Healy is closing up rapidly behind it.

At the science meeting at 1830 today, Borden reported that the starboard compressor was now out of operation because the oil tank had come off its bracket. It cannot be welded at sea. The rest of the system is working well with the leakage on the streamer is at the lowest level yet after it had hung below the ship for hours during the period of electrical problems on the ship. As we are running out of time to do seismic reflection profiles it is comforting to know that the ice conditions are also limiting are ability to collect data.

Barb suggested that the high pressure system we were in was being compressed by a low so the winds may come up tomorrow as usual the ice conditions are deteriorating.

At 1900 Kelley Brumley gave a talk on the formation of the Arctic Ocean what the data from the summer of 2008 would change our perceptions. Her analogue of sea ice motions for plate tectonics for plate tectonics was well received by the ship's company.

The daily intentions were distributed in the evening. I went to bed hoping the gear would survive the night in the ice.

## **Day 269 September 25, 2008 Thursday**

-9.5°C

The seismic reflection system operated all day and at the 0745 safety meeting there were no safety issues. I repeated the questions. Are there any safety issues? The

quality of the data on the display in the lab was excellent. It shows the sedimentary section is at least 3 seconds thick here.

At 1330 the airgun array was pulled from the water at the end of the last seismic section. The technical team was all on hand and Debbie and I viewed the proceedings from the 'tween decks. I was given the honour of disconnecting the firing line. I thought that was a considerate and sensitive of the group. After the air guns were onboard, we met in the board room to distribute two free pop or beer tickets that must not be given away or traded. We also signed two logos one for the Captain of the LSSL and the other for the Captain of the Healy.

The helicopter was circling above the two ships for the entire rafting process with Ryan, Kelly Hansen and the official photographer from the Healy. Jim, the pilot, did lots of fancy swoops and bypasses that actually caused one of the camera guys to be ill. The two ships began rafting together around 1500; Captain Rothwell did a skilled job in drawing along side the Healy that had put her bow into a flow. There was about an hour of manoeuvring before the ships were placed so that a gangway could be constructed between. Meanwhile there was furious activity from the logistics and chefs' department. The helicopter was tied down outside the hangar. Inside, tables had been set up with table cloths, a display with an ice sculptor of a dolphin, and many hot trays. The Healy chefs arrived with their contributions. The meal was lavish, hot and well done. The variety was amazing. There were lobster tails, King crab legs, planked salmon, shrimp, and scallops sautéed on demand, steaks done on the barbecue, chicken and ribs.

After the splendid meal with Hawaiian lads and ladies, there were the exchanges of plaques. I was fortunate to receive one as well as Borden and Jonah. The wooden plaques were made by Eugene, the ship's carpenter. I do not know who did the engraving. It was highly enjoyable ceremony.

Later Jon Childs took Jon Biggar, Fred Oliff, Donald and I on a tour of the Healy. I purchased a fancy cappuccino and a tee shirt. I saw the spacious Bridge, the high Loftcon and the huge labs. LSSL seemed small and cozy in comparison.

The ships remained rafter together all night although personnel returned to their respective ships at 2200. The engineering staff on LSSL had a major maintenance project on one of the engines that would not be completed until 0400 in the morning.

## **Day 270 September 26, 2008 Friday**

-10°C many tenths ice, perhaps 30% grey to grey white

The ships separated at 0600 hours and began to make their way towards the 2500m contour with the LSSL in the lead and the Healy collecting good quality swath bathymetric data. At 0900 we stopped for an hour to calibrate the signature of the three large air guns (520 in<sup>3</sup>) firing simultaneously from one sled. There were a few teething problems getting the air to the guns that were solved only to have the monitoring system fail. We did not have time to fuss so the airguns were brought back on board for the last time this trip. Borden thinks that the calibration phone system has just proved too unreliable and another should be purchased.

We began the bathymetric program again at 5 knots and realised we were short of time, so after consultation with the Healy science staff, increased the speed to 7

knots. The ice conditions were favourable as we travelled along a long lead. Since they did not get back to us we have assumed that the data quality is reasonable.

Kelley and I chatted about her needs for her thesis from our data set. In particular, she would like access to line 8 from the Chukchi to the Alpha Ridge and to line 9 Alpha Ridge to the Canadian margin. She could also get the results from the sonobuoys to model the gravity in the basin. All this needs more discussion with Debbie and Jacob.

At 1500 the Captain and Mate invited Debbie, Kelley and I for green tea in the crow's nest. The climb up was cold on the hands and the reward of the view was well worth the minor discomfort. The Crow's nest itself was heated and quite comfortable. Pictures taken in the Crow's Nest show big smiles on all our faces. There is a plan to make this an event on each cruise.

Bathymetric and marine mammal observations continue 24 hours a day. The seismic crew is preparing the compressors for the long voyage back to Halifax through the stormy Labrador Sea. The streamer will be placed in four boxes and shipped home by air because it must have extensive repairs before the next program.

### **Day 271 September 27, 2008 Saturday**

-12.5°C cloudy little open water. The ship is maneuvering in newly frozen leads away from the 2500m contour toward the centre of the basin.

We crossed the 2500 m contour on the most westerly line at about 0600 this morning. We did not cross on the line 50 NM to the east due to the distribution of multiyear ice and the time left in the survey.

The seismic crew is engaged in cleaning, dismantling and packing up the equipment. Kelley and Steve will return to the Healy today and John Stewart, the Canadian Captain that sailed on the Healy as liaison, will come to the LSSL.

The Healy did a sail pass at 1915 disrupting the regular science meeting. We all went out to wave and listen to the horn blowing. Jon Biggar and I prepared a position to give to the Healy to cross before heading to Alaskan waters to ensure the foot of slope was reached. The LSSL and Healy separated at about 2330 last night. Bathymetric watches continued overnight.

### **Day 272 September 28, 2008 Sunday**

-9.5°C

At the morning safety meeting, Peter and Borden discussed reducing the fumes generated by the solvents used to clean the airguns. A fan from the exercise room was considered to increase air flow. Because we will be in open water today and the winds are predicted to pick up, Borden made it a point to make sure all the gear was properly secured.

Ice conditions continued to improve all day as we headed south to Tuktoyaktuk for refueling. At 1500 when we met to deliver Jon Biggar's birthday card computer, crafted by Fred, the waters were free of ice. During the rest of the afternoon, the technical staff met to brainstorm on suggestions and improvements for next year.

At this point in time they have about 108 recommendations for improvements to the technical aspects of the cruise. This is more than last year but the items are of less consequence and less expensive except for the purchase of additional spares for the streamer. This could amount to half a million dollars. It was the obvious weak point of this season.

The streamer sections have been dismantled, checked over and put in 4 boxes for shipping back to GSC(A). Hopefully, they will travel on the same charter aircraft that we fly home on. Many of the sections will have to be returned to the manufacturer in the US for rebuilding; a time-consuming process. Borden has to call the Coast Guard Base to determine if this is possible. Usually the air craft is full with fresh supplies on the way north and has space on the southern leg.

Most individuals at the meeting plan to have their cruise report submitted in the next day or so. Debbie and I have been busy producing figures for the cruise report, plotting data and writing thank you letters. We have chosen 5 sections of the data for possible figures in the EOS article (newsletter of the American Geophysical Union). John Shimeld kindly offered to cut the sections out of the SEG Y files.

### **Day 273 September 29, 2008 Monday**

-4.3°C snow, perhaps 2/10 small flows, snowing

At about midnight, the ship received a search and rescue call. We are now headed towards Sachs Harbour on Banks Island. There is a missing hunter and they have need of the ship's helicopter. This probably means the ship will not refuel on our leg of their voyage.

I prepared and posted a note about our data display for the ship's company tonight. There are two posters one in each of the messes. A notice was also put on the LSSL television channel. I contacted Kevin DesRoches to insure that the flight for the guys from Paulatuk was organized. It is complicated by the fact that the helicopter may put them ashore on the way to Kugluktuk. I also asked Kevin to book a board room for Friday afternoon. He said he would take care of the details. I got the addresses of the Commissioner of the Coast Guard and the Director-General of the Fleet.

The figures Debbie and I had chosen last night have two problems. One was that the CMP had changed because of the new plotting convention and this necessitated repacking them. The second was one of the BSR was in a region where the ship was backing and ramming and there was a data gap in the middle of the section we wanted to display.

The Captain needed a figure for a press release and I delivered one to him. I received from him several of Kelly Hansen's photographs of the two ships rafted together.

During the afternoon, the sea state began to rise and the ship to roll. Not every one attended supper. The remarkable event today was the Snowy Owls that landed on the flight deck. There were five on the deck and at least another three in the air. They are obviously the birds that the Ookpik is modeled on.

Borden finished his section of the cruise report and handed it in. After the last science meeting at 1900 we held the data display. The Captain, John Stewart the

CCG liaison on the Healy, and the First Officer all seemed particularly interested in the relevance of the data for UNCLOS and its scientific importance. The attendance from the crew and cadets was less than expected. This low attendance was probably due to the sea state; many were feeling seasick.

### **Day 274 September 30, 2008 Tuesday**

-4.3°C sunny later in the day

The winds were too high to fuel, so the ship left the neighborhood of Tuktoyaktuk and steamed toward Kugluktuk. This meant they would be passing Paulatuk today. The four staff from Paulatuk were prepared for the possibility of a helicopter flight to their local airport and were packed in plenty of time. There was concern about the total weight of their baggage so they weighed every item on the scale in the gym. The total was 288 lbs.

The Captain presented the marine mammal observers and Nelson with a certificate for the voyage and said he hoped they would all be back next year. We all went to the flight deck to wave good bye to them as well. They will be missed. Nelson hopes to work with Borden on the Hudson refraction cruise next year.

During the day John Shimeld completed his section of the cruise report and handed it in.

Debbie and I looked at the data one last time before rolling up the records. The stratigraphy on line 5 in the middle of the basin is almost identical to line 11 on the Canadian polar margin. This is not the pattern you would expect from sea floor spreading that had occurred here.

In the evening there was an awards ceremony with certificates handed out to all by the Captain. Awards were given to those who had lost the most weight called the biggest loser and trophies for the cribbage and Wii tournaments.

### **Day 275 October 1, 2008 Wednesday**

-1°C windy choppy sea

The ship was near Cape Hope in Dolphin and Union Straits with the CCG Sir Wilfred Laurier nearby. The winds were too high for the ships to raft together to put the container from the previous science mission on board. Anything that can be moved by helicopter will be. The CCG is certainly actively supporting science in the Arctic.

During the day, the winds reached 45 knots. Wet snow splashed across the windows in my cabin as I packed up. John, Debbie and I met to discuss the critical issues for next years experiment. Finding the right people for the cruise next year was the single most important item.

At about 2030 the Captain announced that our charter for the return flight would not arrive tomorrow due to mechanical problems. A sigh went around the ship.

### **Day 276 October 2, 2008 Thursday**

sunny calm seas at anchor at Kugluktuk

Shigeto Nishino left today as his flight is on a commercial airline to Edmonton, Seattle and Osaka. He has been away from his wife and two children 4 and 6 years old for 3 months. We wished him bon voyage. The 4 boxes with streamer parts were also slung ashore.

I spent the day working on the cruise report and preparing a power point presentation.



## 3 Weekly Messages

### 3.1 Sunday August 24, 2008

#### UNCLOS – CCGS Louis S. St Laurent Hydrographic program

Highlights: departed Burlington, bathymetry program started, ice conditions in survey area look promising for project

Weekly Summary: Aug 20 to 24

Aug 20 Wednesday – departed Burlington, over night in Dartmouth

Aug 21 Thursday – departed early morning from Coast Guard base to airport, departed 7 AM for

Kugluktuk, stop over in Iqaluit for crew change and fuel, arrived Kugluktuk at 2:30 PM, onboard ship later that afternoon and settled in

Aug 22 Friday – finding and sorting gear, ship orientation and safety meeting, fire drill, creating plan

lines/waypoints for ship and helicopter spot sounding, departed Kugluktuk late morning for survey area

Aug 23 Saturday – preparing and checking equipment for ship and helicopter data collection, spot sounding

briefing with helicopter crew

Aug 24 Sunday – started sounding operations in AM, proceeding to start of planned survey line

Plans: SVP cast and bar check the ship sounder at the start of the planned seismic line, NRCAN calibration of seismic gear, when completed start survey operations 24/7 along with helicopter spot sounding program.

#### Seismic and related programs

The ship steamed out of Kugluktuk on Friday morning at 1100 hr local in calm ice free waters. It was not until Sunday morning at 0400 that we first encountered ice.

The marine mammal observations started immediately. Two beluga whales and a small number of seals have been spotted.

The task of unpacking and setting up the seismic reflection system is underway. Both tow sleds have the airguns attached. The bundles of electrical and high pressure air hoses with protective wrap that supply the airguns have been assembled. The high pressure bottles have been set up. The starboard compressor is ready to be tested tomorrow. The reels for the hydrophone arrays have been modified so that they will spool both out and back with the remote controls. The sonobuoy antenna has been mounted in the crow's nest. The sonobuoy receiver is set up behind the Bridge and data can now be accessed from the seismic lab because the network is operational. We will reach the start of line early Monday morning but will require at least another day to assemble the hydrophone array before the test sequence can begin.

The gravity meter is operational. It has survived the ship backing and ramming when an old flow crossed our path.

## **3.2 Sunday August 31, 2008**

### **UNCLOS – CCGS Louis S. St Laurent**

Along the ship's route in the Canada Basin, we have encountered waters that are either ice free or with only a low concentration of ice in small flow. Nilas is beginning to form; this is taking place earlier than last year. The sea state has been low.

The streamer tests were completed successfully and give good insight in to the noise on the seismic sections. However, the air gun calibration failed due to the failure of the receiver for the calibrated hydrophone. The air gun calibration will be attempted again when there is time to trouble shot the electronics. By Sunday morning at 0900 we had collected 447 km of good quality seismic reflection profiles and 10 sonobuoys. We have closed the gap in the seismic sections from 2007 and the USGS lines.

The gravity meter has twice gone out of level and been restarted. The software for acquiring the seismic profiles is proving to be unstable. We were not able to get the latest version due to import license problems. The compressor continues to be unreliable with a failure in the high pressure fourth stage discharge pipe and pipe coupling. This is same pipe and coupling failure as on last years cruise. The equivalent high pressure pipe and coupling from the port compressor was installed in the starboard compressor. Unfortunately, this pipe has cracked and is leaking as well. An intensive effort to manufacture a replacement part that will withstand the pressure, vibration and torque is underway.

Please acknowledge receipt of this message.

## **3.3 Sunday September 7, 2008**

### **UNCLOS – CCGS Louis S. St Laurent**

#### **Seismics:**

We encountered ice conditions that were suitable for the CCGS Louis S. St-Laurent ship to collect seismic reflection profiles in the Arctic Ocean without an escort until we reached 81N. From here we continued north collecting bathymetric data. With the USCGC Healy 48 hours away it seemed prudent not to damage the gear. This week we have collected 810 km of reflection profiles. The data quality continues to be of high standard. The thick sedimentary section and basement are clearly imaged. A striking regional trend in the basement shallowing across the basin toward the Northwind Rise is observed.

We have launched an additional 10 sonobuoys. We have had a number of failures where the sonobuoy recording abruptly terminates. The problems with the gravity meter are not easy to fix at sea especially with the technical support occupied with more pressing problems. Therefore the meter has been caged and turned off. Both compressors are now operational although it takes considerable effort for this to occur. The universal joint on the original compressor has just been replaced for the third time in less than 700 hr of operation. Peter Vass is kept busy making brackets

to steady portions of the compressor that shake loose and welding every joint. Yesterday three different stages had to be rebuilt on the original compressor.

**Hydrography:**

Highlights: seismic and hydrographic program continues with light ice (no ice) conditions, 1700 kms sounded to date, seismic air compressor still problematic, SVP (sound velocity) and XCTD (expendable conductivity, temperature and density) casts completed and ship bar check, helicopter spot sounding collection has started, seismic operations suspended because of ice late Saturday afternoon, sounding ops is continuing to 2500 metre contour

**Weekly Summary: Aug 31 to September 6**

Aug 31 Sunday – stopped in ice early AM, recovered gear, repairs on compressor and airguns, bar check ship, problems locking digitizer on to the bar (cone), weather standby for helicopter

September 1 Monday – seismic and sounding ops, helicopter out after lunch and dinner, 19 spots soundings collected, the new Knudsen chirp system first employed unsuccessfully, switch out and used Knudsen 320A, water depth in excess of 3800 metres.

September 2 Tuesday – seismic and sounding ops, into US waters, weather standby for helicopter, XCTD program started by Shigeto Nishino, helicopter sounding suspended while in US waters

September 3 Wednesday – seismic and sounding ops, air guns recovered for maintenance, problems with the geophone streamers, leaking in water, SVP cast in afternoon to 2500 m

September 4 Thursday - seismic and sounding ops all day

September 5 Friday - seismic and sounding ops, seismic gear recover for maintenance, CDGPS corrections are not reliable

September 6 Saturday - seismic and sounding ops, seismic operations stopped late afternoon because heavy ice conditions, gear onboard, continuing sounding to 2500 contour



**Figure 3.1 Progress to September 6. The blue line is the planned route, yellow the completed to date.**

Plans: Continue seismic and sounding data collection, continue helicopter spot sounding program and rendezvous with the US Coast Guard icebreaker Healy early next week for ice breaking support for the next leg of the program

Please verify receipt of message and/or attachment. I expect you will not get it until we are further south.

Cheers Ruth

### **3.4 Sunday September 14, 2008**

#### **UNCLOS – CCGS Louis S. St Laurent**

##### **Seismic program:**

At the northern end of our survey the ice was heavier and the decision was made to protect the reflection equipment until the USCGC Healy met the CCGS Louis S. St-Laurent. Collecting bathymetry on the Alpha Ridge was the priority to determine an accurate foot of slope. On September 9, 2008 at 1630 the two ships were at the same location and the Captains and Chief Scientists met on the Healy to coordinate the upcoming program. Healy took the lead and by 0016 the first air gun shoots were fired. Seismic profiling took place in increasing heavier ice conditions. 270 km of good quality reflection profiles were collected in up to 10/10 ice with moderate pressure. The tow sled had made at least five complete rotations on itself and at times it had been necessary to use all three propellers and full power. The seismic system was recovered with little damage other than clamps and other expendables.

Based on the newly acquired information foot of slopes were determined at 81.68°N 140.2°W on the Alpha Ridge and at 80.25°N 128.68°W off the ridges on the northwest of the tip of Prince Patrick Island. The seismic line shows two seconds of sedimentary section near the 3000 m contour. Seismic reflection was halted at 80.638°N 130.4°W due to endless multiyear pressure ridges. The combination of FOS plus 60 NM and FOS plus sediment thickness overlaps.

The ships continued onwards with the Healy collecting multibeam to the 2200 m contour and then turned basinward again. The LSSL was in the lead, which improved the multibeam data quality. For several hours between 2230 and 0030 on September 12, it required both ships abeam backing and ramming out of phase to escape the moderate pressure in the multiyear ice pack. The cooperation between the two ships is a joy to take part in.

Ice conditions improved on September 13 and the seismic reflection profiling is taking place now as we move towards the 350 nm cut off with an additional 70 km of reflection data collected up to 0800 on Sunday.

### **Hydrography:**

Highlights:

- seismic and hydrographic program continues; good progress made to date
- a number of SVP (sound velocity) and XCTD (expendable conductivity, temperature and density) casts completed
- met up with the ice breaker USCGC Healy
- 51 spot sounding collected
- 2858 line kilometres sounded to date

### **Weekly Summary: September 7 to September 13**

September 7 Sunday – sounding ops continue, sounding data drop outs when heavy ice breaking but still usable

September 8 Monday – sounding ops continue, extended survey lines to better define the 2500 metre contour

September 9 Tuesday – sounding ops, SVP cast to 2850 metres, meet up with Healy, tested Knudsen 3210 sounder off stern, difficulty picking up bottom at 2960 metres, draft of ship measured by small launch to validate numbers used in post processing of sounding data, weather standby for helicopter, seismic operations began around midnight

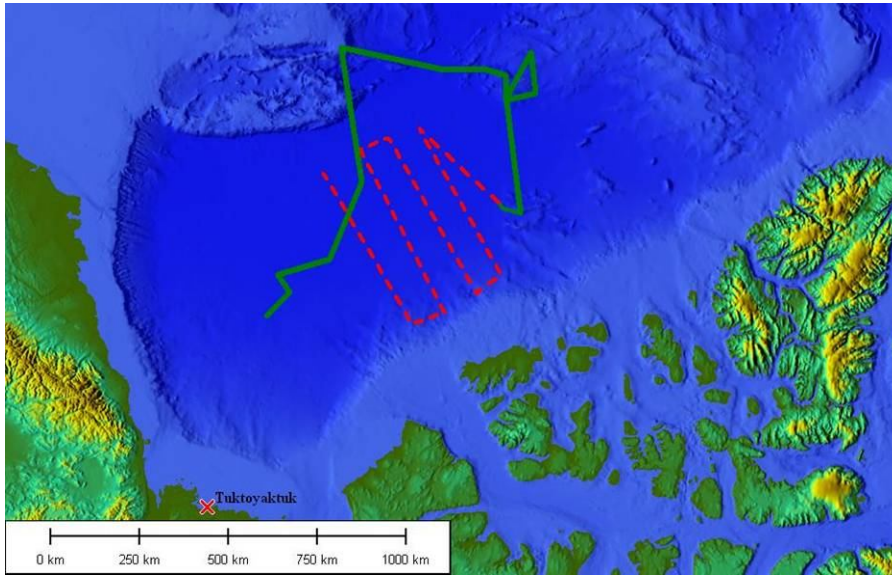
September 10 Wednesday – seismic and sounding ops, Healy escort, two helicopter spot sounding flights in late afternoon, ice is heavier further south we travel

September 11 Thursday - seismic and sounding ops, Healy escort, into heavy ice now, one helicopter flight for spot soundings, started receiving CDGPS at 80-52N/133-05W, pulled seismic gear at 11 PM and continued sounding towards the 2500 metre contour

September 12 Friday – sounding ops, moving slowly to the 2500 metre contour, Louis S St Laurent lead ship for Healy, Healy is collecting multibeam data, stopped late afternoon and turned in direction of new seismic line, one helicopter spot sounding flight early afternoon

September 13 Saturday – seismic and sounding ops, Louis lead ship and Healy following collecting multibeam data, moving toward lighter ice conditions to deploy seismic gear, SVP cast to 3500 metres and XCTD deployed, seismic gear deployed late afternoon with Healy escort

Plans: Continue seismic and sounding data collection with the help of Healy and continue helicopter spot sounding program.



**Figure 3.2 Progress to September 13. The green lines are completed and the red are planned.**

### **3.5 Sunday September 20, 2008**

#### **UNCLOS – CCGS Louis S. St Laurent**

##### **Seismic operation**

The cooperation between the Canadian and American Coast Guard vessels LSSL and the Healy have been essential for collecting seismic reflection and multibeam data. The ice has been under moderate to light pressure in the northern and eastern parts of the survey area making it difficult for single ship operations.

This week we have collected 620 km of seismic reflection data. We have verified the bathymetric rise northeast of Prince Patrick Island. The seismic data was noisier than usual on the line that starts near this bathymetric rise. The airgun sled and eel were brought on deck and adjustment made to the way the streamer was being towed. This improved the data quality to the best collected in the last two years. The seismic profile located just to the south of the bathymetric rise off of Prince Patrick Islands shows basement shallowing as we approach the slope. The combination of large negative circular gravity anomaly, magnetic lineations and basement high suggest we have crossed the remnants of a large volcanic feature along the margin. This is the third such feature we have crossed in the UNCLOS experiments; one on the Lomonosov Ridge and another at the mouth of Nansen Sound.

Much of the week was spent in heavy ice with the LSSL as the lead ship acquiring multibeam data for foot of the slope determinations. On Saturday the seismic gear was put in the water again and reflection profiling was done until the hydrophone array failed Sunday morning. The heavy ice conditions are taking their toll on the equipment. Repairs are underway.

### **Hydrography:**

#### Highlights:

- seismic and hydrographic program continues, good progress continues with the help of the ice breaker USCGC Healy,
- a number of XCTD (expendable conductivity, temperature and density) casts completed,
- 108 helicopter spot sounding and 4008 line kilometres sounded to date.
- Healy is collecting 3.5 KHz single beam and deep-water multibeam data.

### **Weekly Summary: September 13 to September 20**

September 14 Sunday - seismic and sounding ops, Healy escort, moving into lighter ice conditions, weather standby for helicopter spot sounding ops

September 15 Monday – seismic and sounding ops, Healy escort, helicopter spot sounding flights in late afternoon, 11 spot soundings, ship stopped for seismic gear maintenance, redeployed air guns and performed sound tests/calibration on the seismic airguns, seismic and sounding ops started approximately 12 midnight

September 16 Tuesday - seismic and sounding ops, Healy escort, weather standby for helicopter spot sounding ops, ship lost its email connections

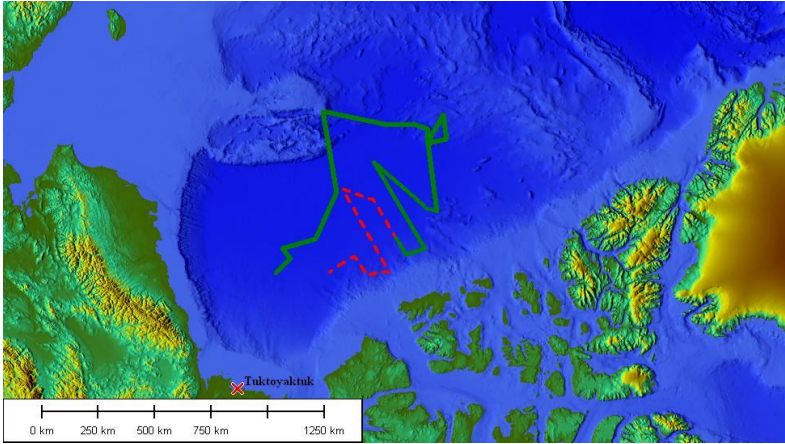
September 17 Wednesday - seismic and sounding ops, Healy escort, weather standby for helicopter spot sounding ops, moving into heavier ice conditions, seismic geophone streamer stopped functioning approximately 7 PM, deployed spare unit and continued operations

September 18 Thursday – seismic stopped at 6 AM because of heavy ice conditions, role reversals Louis lead ship now escort for Healy and the collection of multibeam and 3.5 KHz data, helicopter spot sounding flights in late afternoon, 10 spot soundings

September 19 Friday – sounding ops, Louis escorting Healy, approximately 6AM cross-over 2500 metre contour, proceeding south to next line

September 20 Saturday - sounding ops, Louis escorting Healy, afternoon helicopter spot sounding flight, 10 spots soundings, seismic gear deployed approximately 20:00, problems with seismic gear, operational later that evening, Healy now lead ship, escorting Louis

Plans: This is the last week of seismic and sounding program. Fuelling of the Louis is schedule for September 27 in the vicinity of Tuktoyaktuk. Once completed, the plan is to make way for Kugluktuk and crew change flight to Halifax on October 2.



**Figure 3.3 Progress to September 20. Completed progress indicated by the green line, planned in red.**



## 4 Technical Report on Bathymetry Acquisition

Jon Biggar

### 4.1 Introduction

The Canadian Hydrographic Service (CHS) is responsible for a number of elements under Canada's effort to delineate the size of the extended continental shelf under Article 76 of the United Nation's Convention on the Law of the Sea (UNCLOS):

- mapping baselines from which the extent of the territorial sea is measured,
- mapping the 2500 metre isobath and the Foot of the Slope,
- optimising the location of boundary lines at calculated distances. (60, 100, 200 and 350 nautical miles), and
- Populating databases with the above data and providing output in the form of charts, maps and diagrams.

### 4.2 Summary

The CHS program was conducted in conjunction with NRCan seismic operations. The program involved two ice breakers, the CCGS Louis S. St. Laurent (Canada) and USCGC Healy (USA). CHS personnel participating in the expedition, Jon Biggar, Fred Oliff, and Donald Kalley, worked on the Louis S. St. Laurent. The escort duties of each ship depended on the science that was being collected at any given time; during seismic operations, Healy was lead and during hydrographic operations, Louis S. St. Laurent was lead. This was done to utilize the best tools of each ship.

Bathymetric data collected on this program will be used to augment and refine the historical information that will be used to establish and support Canada's UNCLOS claim.

The success of this year's program can be contributed to the dedication and hard work of the captains and crew of the CCGS Louis S St Laurent and the USCGC Healy and the all support staff.

### 4.3 Sounding Methods

Two sounding techniques were employed; conventional ship configuration and helicopter spot soundings. The ship navigated along predetermined transects dictated mostly by the requirements of seismic operations, and the helicopter was deployed to collect spot sounding data between the survey lines. The ship logged 5500 line kilometers and the helicopter collected 158 spot soundings (\*\*Figure 4.1\*\*). The helicopter, a Messerschmitt MBB BO105, was used to maximize the area covered and to collect data inaccessible to the ship because of ice conditions.

Virtually the same equipment was used for both platforms, (See Table 4.1 for equipment list).

The USCGC Healy joined the program on September 9<sup>th</sup> and departed September 27<sup>th</sup>, during which time additional hydrographic data was collected including deep water multibeam and 3.5 KHz single beam by USCGC Healy.

The ship collected soundings using the Knudsen 320B/R Plus sounder attached to a 12 KHz transducer. The system used Chirp pulse generation technology. The echo sounder performed well although the settings in deep water (2500 metres plus) were set at maximum values to acquire the data. As is common when sounding in ice, bottom detection was sometimes lost due to interference from ice (Figure 4.2).

#### Table 4.1 Major equipment list

##### CCGS Louis S. St-Laurent

Knudsen 320 B/R Plus sounder  
12 kHz transducer  
Novatel DL V3 GPS receiver / Novatel L Band antenna  
Desktop computer / Hypack, Knudsen, and CARIS software  
SV Plus V2 (sound velocity meter) – depth range 5000 m  
MK21 USB DAQ – Bathythermograph Data Acquisition system and  
LM-3A Handheld Launcher  
Lockheed Martin Sippican  
XSV02 (Expendable sound velocity probe)  
XCTD (Expendable conductivity, temperature, and density probe).

##### CCG Helicopter 363 (B105)

Knudsen 320A sounder (variable frequency capacity)  
Knudsen Chirp 3210 sounder 12/24 kHz  
Knudsen 320M sounder 12/24 kHz  
12 kHz Knudsen transducer  
Novatel Propak V3-RT2 GPS receiver / Novatel L Band antenna  
GoBook XR-1 laptop - Hypack and Knudsen software

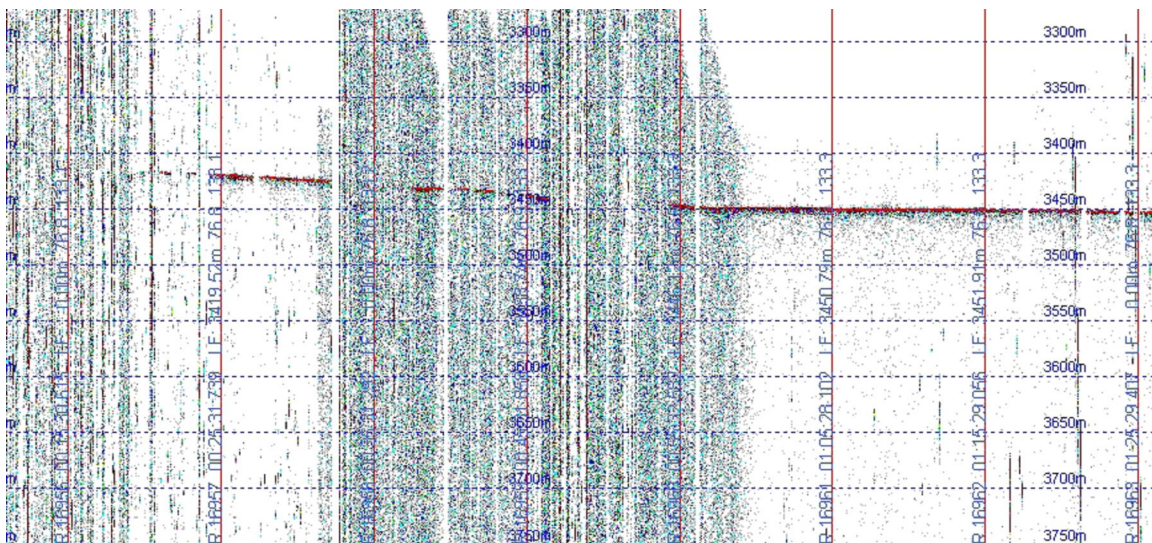


Figure 4.1 The central portion of this echo-trace record shows how the traces become lost due to interference from ice.

Knudsen Echo Control Client V1.47 and Echo Control Server V1.44 software were used for acquisition and PostSurvey V2.24 software was used for viewing during post processing of the data.

#### 4.4 Positioning Methods

Both on the ship and in the helicopter, Novatel Propak V3 GPS receivers with L2 antennas were used for positioning. Differential corrections were received from the nationwide CDGPS service by means of MSAT satellite communications. Differential corrections are based on algorithms developed by Natural Resources Canada (NRCan) and real-time positioning data from Canadian reference stations. The estimated positional accuracy was 2.0 metres in static mode. Differential corrections were received approximately 50% of the time due to limitations in the MSAT satellite coverage (Figure 4.3). Without corrections, the positional accuracy was 5.0 metres. All equipment performed well overall.



Figure 4.2 MSat coverage map for CDGPS corrections.

#### 4.5 Data Collection

Hypack V6.2 (single beam survey module) was used for data acquisition and survey planning.

Full ocean depth sound velocity and temperature data were acquired using an Applied Microsystems SV Plus v2, which was deployed from the ship's foredeck starboard A-frame with the ship at full stop. Measurement accuracies from the manufacturer specifications are:

- sound velocity, 0.05m/s with 0.03 m/sec precision,
- temperature, 0.005°C, and
- pressure, 0.01% full scale (depth accuracy approx 0.5m).

In all, six profiles casts were taken with maximum depth of 3850m (Figure 4.3).

Numerous Expendable CTD (XCTD) and sound velocity (XSV) probes were launched from the stern using a Sippican LM3A Handheld launcher and MK21 Data Acquisition System (Figure 4.4). It was best to launch with the ship stopped, however the probes were also launched while the ship was underway at 4 knots towing seismic gear. The Sippican XCTD-2 probes provide temperature, conductivity (salinity) and depth information with measurement accuracies of  $\pm 0.02^{\circ}\text{C}$ ,  $\pm 0.03 \text{ mS/cm}$ , and 2% respectively. The XCTD-2 has a maximum depth of 1850m.

- sound velocity,  $\pm 0.03 \text{ m/sec}$
- temperature,  $\pm 0.02^{\circ}\text{C}$
- depth,  $\pm 2\%$  water depth

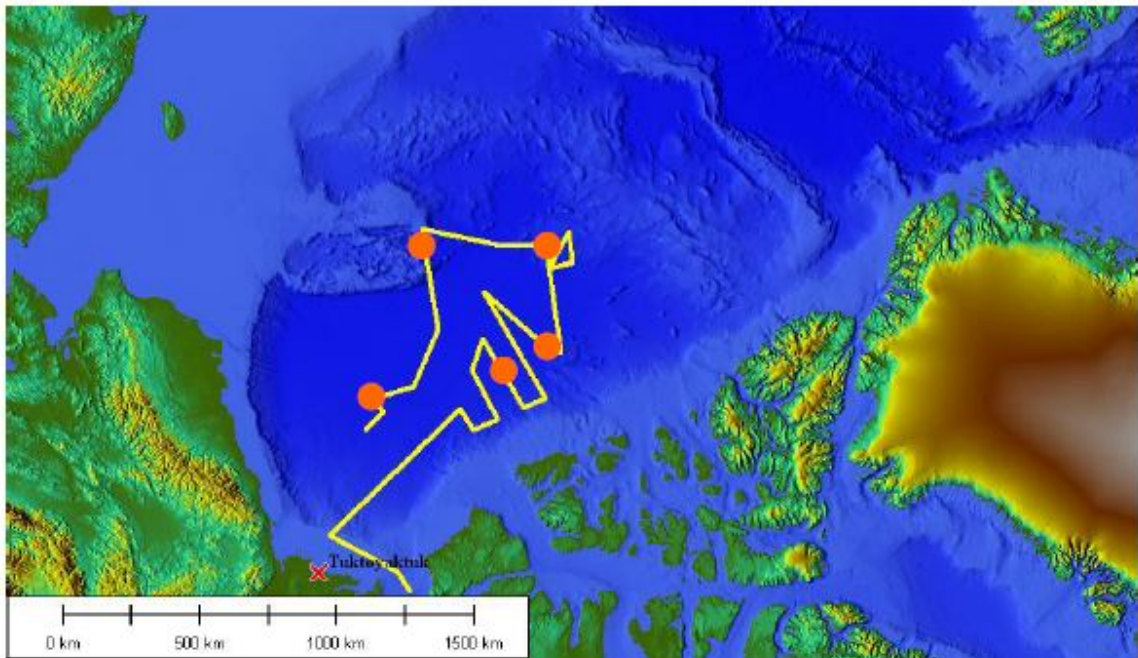


Figure 4.3 Location of full ocean depth SV probes.



Figure 4.4 Fred Oliff launching an expendable CTD.

## 4.6 Data Processing

CARIS GIS v4.4 was used to manage, compile, and view the processed bathymetric data. CARIS HIPS v6.1 was used to process survey position and depths. The processing sequence was:

- File conversion from Hypack to HDCS (CARIS multibeam) format,
- Edit vessel position data,
- Apply vessel gyro data,
- Clean/edit sounding data in HIPS' Single Beam Editor, and
- Apply tide data and sound velocity data and generate final sounding.

A bar/cone check was performed to verify the vessel draft, but as a result of wind and sea conditions it was not successful on two occasions. The ship's draft was verified weekly and confirmed by deploying a small launch to read the draft marks.

## 4.7 Recommendations and Conclusions

As suggested in the previous year's cruise report, the ship should be outfitted with another 12 or 3 kHz transducer for redundancy. If for some reason the existing system fails, there is currently no alternate method for bathymetry collection in deep water.

Knudsen sounder tests revealed that using a tone signal pulse with a paper graph for bottom detection works better than the CHIRP pulse. In addition, it is more user-friendly for helicopter spot sounding operations. Problems experienced in previous years with the connection with the ship network and the Knudsen sounder control and data logger were eliminated with the new system was installed over the winter.

Three CHS staff is sufficient for sounding operations onboard ship.

## **4.8 Acknowledgements**

CHS would like to thank NRCan for their help and support and the Captain and crew of the CCGS Louis S. St-Laurent for their assistance carrying out the UNCLOS project objectives.



## 5 Technical Report on the Seismic System

Borden Chapman





# Technical Review of the Operation of an Ice Strengthened Towed Seismic System in Canada Basin 2008

## 5.1 Introduction

In the late summer of 2008 Natural Resources Canada supplied equipment and personnel to undertake a seismic program to determine sediment thickness in areas of the Canada Basin. The program used the Canadian Coast Guard Ship Louis S. St. Laurent as the operational platform for a six week period commencing August 21<sup>st</sup> and running through October 3<sup>rd</sup>, 2008. For a three week period beginning September 9, 2008 the USCGC Healy was used as an escort vessel to provide ice breaking for the LSSL while gear was deployed.

## 5.2 Historical Background

In 2006, on board the icebreaker CCGS Louis S. St. Laurent, NRCan employees tested a prototype seismic tow system designed to function in Arctic sea ice conditions. The program evaluated the performance of a prototype "tow sled" capable of withstanding direct interference with sea ice while being towed immediately behind the vessel at speeds of 3-4 knots. NRCan staff also assessed ship's laboratory facilities and the existing handling equipment fitted to the quarterdeck and reported their findings in a final cruise report submitted to both CCG and NRCan managements.

During the winter of 2007 most of the recommendations in the previous year's report were acted upon. Modifications were made both to vessel and tow sled system. In the late summer of 2007, a six week program was successfully completed using the modified tow sled system, improved handling equipment and laboratory space on LSSL. At that time approximately 1800 nautical miles of seismic reflection data was collected along with refraction data from a total of 28 sonobuoys. As a result of the 2007 program, additional recommendations for refinements to the tow system were made. During the winter of 2007-8 these recommendations were implemented netting further improvement to system durability and performance in heavy sea ice conditions.

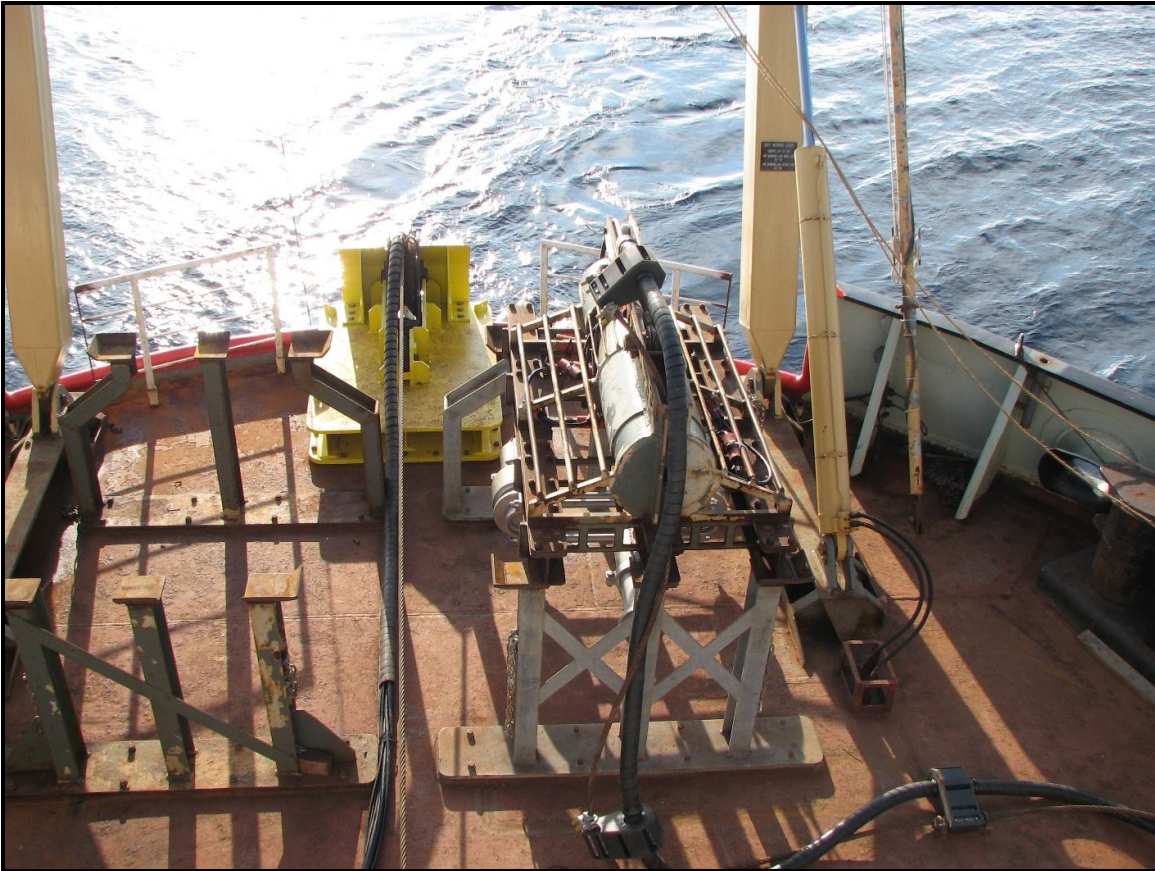
## 5.3 Equipment

In this report five specific equipment categories will be discussed. Each category will be further split to deal with individual pieces of equipment. Equipment problems which arose during the program will be noted along with suggestions for corrective solutions.

The five major equipment categories to be described in detail are:

1. Tow sled and G-gun equipment;
2. Compressor and air distribution system;
3. GeoEel streamer system;
4. Sonobuoy system;
5. Data Distribution on the vessel.

### 5.3.1 The Tow Sled System



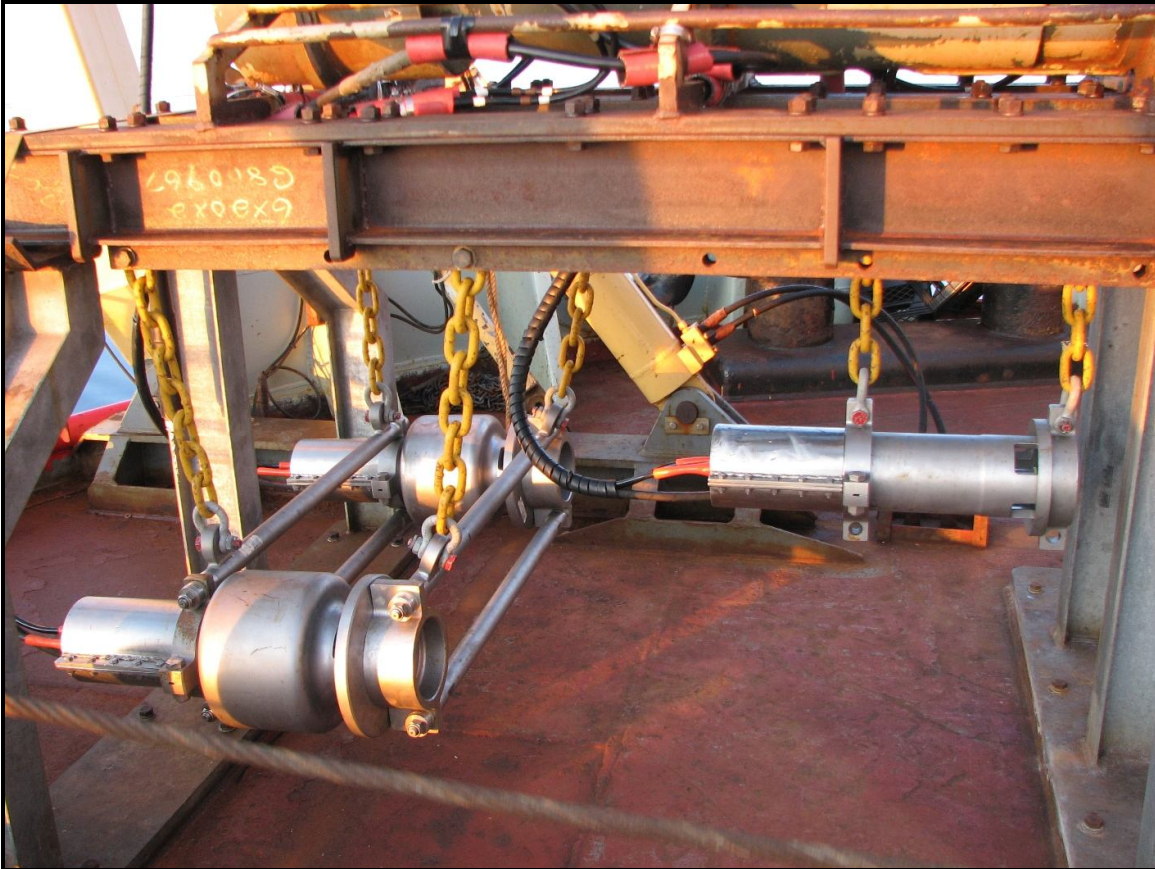
**Figure 5.1 Port Tow Sled on its bench with 3- Sercel "G-guns" fitted, 2008.**

Figure 4.1 shows the port tow sled system including the cylindrical 3500 pound hydrodynamic depressor weight at the top. The depressor was bolted to the gun "cradle" built from 3 re-enforced steel "I" beams. Chains attached to the gun cradle support 3 Sercel G-guns. Pull and lift points positioned on the top of the depressor weight allow for towing and recovery. The sled footprint was deliberately kept small to minimize the available area for contact with the sea ice. Dimensions are approximately 40" (1 meter) wide by 70" (2 meters) in length by 40" (1 meter) high. Total weight of the sled, with guns fitted, is approximately 5500 pounds. While submerged, the tow sled trails well immediately behind the vessel with very little yawl or attitude change even during times when heavy power is applied to the ship's propellers.

Benches were fitted to the deck of the vessel allowing storage of the sleds during transit (See Figure 4.1). The bench also allows access to the 3- Sercel G-guns and to the piping and all electrical connections when service is required.

Suitable bars and guards were added to the body of the sled to accommodate routing of hoses and electrical cables. They also protect the air and electrical cables from contact with sea ice during towing, deployment and recovery. A duplicate tow sled system was built and installed on the vessel in 2007.

During the winter of 2008, the two tow sleds were extensively modified to strengthen the lower half of the structure, now known as the “gun cradle”. Heavier “I” beams were incorporated in the design. A number of “stiffeners” were added between the “I” beams and along the beams’ outer edges. Also, the cradles were modified to allow easy replacement if structural failure occurred. The gun cradle was bolted to the depressor weight as shown in Figure 4.2. Four modified gun cradles were constructed for the 2008 survey season.



**Figure 5.2 Sercel G-guns when fitted to the re-enforced tow sled cradle in 2008. The gun cradle can be removed from the depressor for service if necessary.**

Shown in Figure 4.2, are the two aft Sercel 520 G-guns fitted with the spreader bars. These were added to the towing arrangement in 2008 as a result of previous years’ experiment. In 2007 the two aft guns, without the spreader bars, contacted repeatedly when fired. The original thought was that the spreader bars would catch sea ice during towing but in 2008 experience showed that the incident of gun/ sled damage due to gun interactions far exceeded that of sled damage resulting from the sea ice impact.

### **Pull cable and cable bundle**

The tow sled was attached to the vessel using a 1” steel “pull cable”. The inboard end of the pull cable was affixed to the aft bollard amidships of the quarterdeck. The overall length of the pull cable was 75 feet. This provides for a fixed pull depth of 33 feet from

sea surface to the top of the tow sled and a gun tow depth of 38 feet. The pull cable had a breaking strength of 100k pounds. On the pull cable there were four “eyelets” installed at 12 foot spacing starting at 12 feet from the top of the sled. These ½” steel cable eyelets were micropressed onto the 1” pull cable. The eyelets were used to aid in deploying and recovering the pull cable. See Figure 4.3



**Figure 5.3 Pull cable showing one of the eyelets used for deployment and recovery.**

The pull cable also served to support the cable bundle. The cable bundle or simply “bundle” was fitted to the pull cable by a total of seven bundle clamps. (See Figure 4.3). These bundle clamps rotate freely about the pull cable but grab the plastic bundle wrap securely. Because the bundle clamps freely rotate on the pull wire, the cable bundle can contact ice and be deflected behind the pull wire and away from the ice. The pull cable will actually help to deflect ice away from the cable bundle in this manner.

On the inboard end, the pull cable was fitted with a 3 foot open eye which fit over the aft bollard. The wet end of the pull cable has a hard eye attached. A two inch steel pin located at the top balance point of the tow sled fits through the eye.



**Figure 5.4 Two assembled tow bundles showing pull cables, bundles, with clamps fitted.**

The cable bundle consists of the following individual components:

1. 3- 2 conductor electrical cables for delivering firing signal voltages to the G-gun solenoids;
2. 3- 2 conductor electrical cables for sending the time break signals from the guns to the shipboard firing control computer;
3. 3- ½"Synflex air hoses for delivering air to each of the three G-guns
4. Armored multicore electrical cable for the GeoEel system.

Omniwrap, a plastic spiral product used in the hydraulics industry, was used to keep air and electrical lines clustered together and help protect these lines from damage during handling and towing operations.

The Omniwrap can be completely removed and reinstalled if cables or hoses inside the bundle need replacement. One of the greatest benefits of the product was that, although it does an excellent job of containing the bundle components, it allowed the individual components to move or "give" inside the bundle in the event of ice contact. This free movement of the cables inside the bundle reduced chances of overstressing the bundle components.

As there are no special armored cables or a custom made umbilical in the NRCan system, repairs require less time and were cheaper to perform.

## Tugger Winches

Each tow sled is raised and lowered using the ship's A frame and the respective tugger winch located on the tween deck. (See Figure 4.5). Each tugger is equipped with 150' length of ½" non-rotational steel cable. The outboard end of each tugger winch cable is fitted with a hard eye and was attached to the respective tow sled by a 1" lift pin, located just forward of the tow sled pull point. When lifted off the bench the sled will tilt downward at the back. This allows for personnel to easily handle the two aft guns electrical and air bundles around the rear bench legs. Note that the A frame was extended slightly outboard (approximately 8"- 10" on the hydraulic rams) to allow for proper tow sled balance and clearance when lifted clear of the bench.



**Figure 5.5** Two recovery tugger winches fitted to the tween deck; also note the hydraulic control station for these winches and the ship's A frame controls.

Acting on one of the recommendations from the 2007 program, modifications to the tugger winches' hydraulic controls were undertaken. The 50 HP pumping unit, providing the hydraulic power for the three tugger winches, was moved inside the vessel to a location under the starboard ladder leading down to the paint locker area below the Av Gas compartment. This provided a more environmentally secure site for this equipment. Additionally the winch controls, previously located on the quarterdeck, forward of the centre bollards, were relocated to the tween deck on a new deck extension platform, between the port and starboard tugger winches. (See Figure 4:5). This provided the winchman better visibility of the quarterdeck area during deployment and recovery operations.

A third tugger winch was fitted to the quarterdeck, on the forward, amidships bollard. (See Figure 4.6). This tugger winch was used in the deployment and recovery of the tow cable and bundle. During these operations the tugger winch cable was attached to the pull cable eyelets and the winch paid out or pulled in. This aided ship's personnel in controlling the rate at which the pull cable and cable bundle were deployed and recovered. Note that the tugger was only used to deploy/ recover the tow sled cable and bundle. The tow sleds were lifted out of the water using the tween deck tugger winches and A frame.



**Figure 5.6 Centre tugger winch mounted on the forward bollard, amidships, used for tow cable and bundle deployment and recovery.**

In 2008 modifications to the centerline roller sheave fairlead system were made. On previous cruises the bundle clamps were becoming caught up on the aft bulwarks and roller sheave base causing safety concerns and handling issues during tow sled recovery. A fairlead system was designed and constructed which better guided the bundle clamps and hose bundle over the large roller sheave. (See Figure 4.7). The modifications made over the 2008 winter eliminated the problems experienced the previous year.



**Figure 5.7 Early 2008 picture taken at the fabrication yard showing the newly fitted fairlead system attached to the LSSL aft roller sheave and base.**

### **Sercel G- Guns**

The sound source generators used for this program were chosen specifically for compact size, peak power and the frequency spectrum of the emitted pulse. Program prerequisites were for a sound source to produce an intense low frequency pressure wave, in the range 2 to 120 Hz, to penetrate up to 5 km of ocean bottom sediments in water depths to a maximum of 5000 meters.

There are three Sercel G-guns fitted to the tow sled: the Sercel 150 in<sup>3</sup> G-gun fitted as the front gun on the sled and two 520 in<sup>3</sup> in the rear. The 150 in<sup>3</sup> gun was added to provide a higher frequency pulse, adding upper frequency content to the pressure wave (see Figure 4.8).

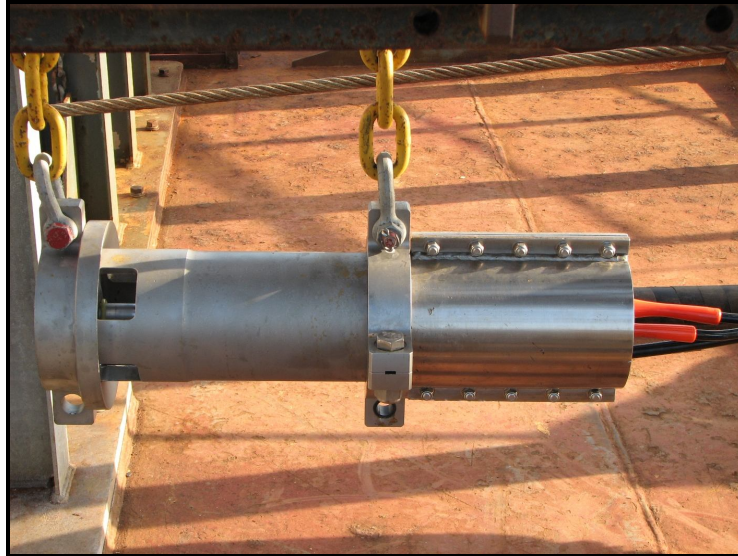


Figure 5.8 150 Cubic Inch G-gun mounted onto the front of the tow sled.

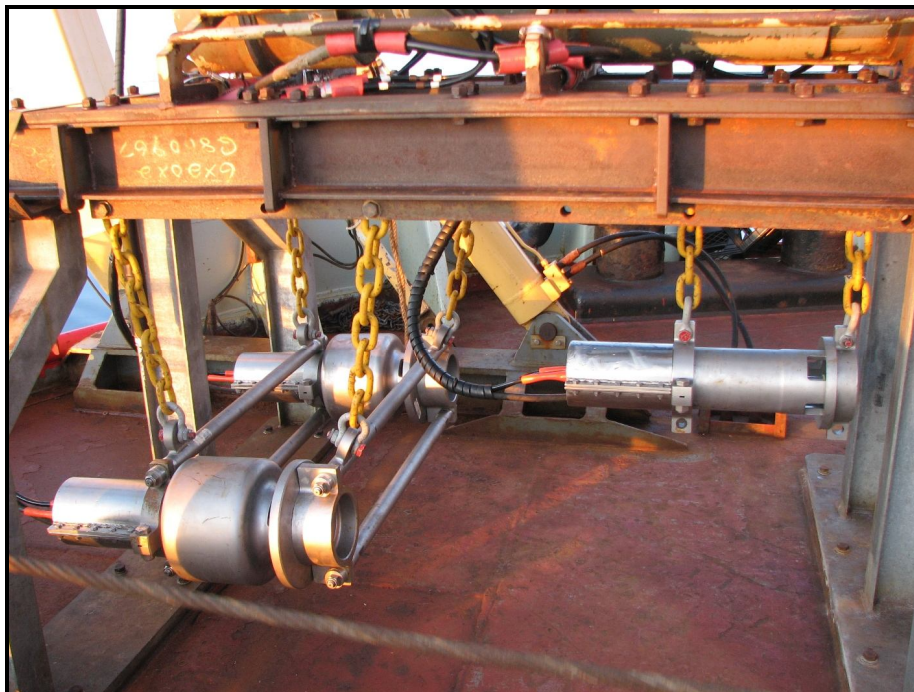


Figure 5.9 The tow sled with three Sercel G-guns fitted, ready for deployment (the 150 in<sup>3</sup> is on the right).

The 520 cubic inch Sercel G-gun has a centre frequency of 40 Hz and peak power of **6.5 b-m** at a tow depth of 30 feet.

The 2- 520 cubic inch G-guns were suspended below the tow sled cradle by grade 80- 5/8" chain. The chain was connected to the Sercel "spreader bars" which fixed the two guns at a specific distance apart while holding them rigidly together. This



greatly reduced the issues of aft gun contact which occurred in 2007 as mentioned earlier (see Figure 4.9).

Gun spacing on the sled was set to specifications provided by Sercel. From port to port, distances were approximately 1 meter. This produced an optimum focused pulse for the intended work.

During the first year of testing and deployment of the tow sled it became obvious that the electrical cables and air line needed extra protection at the guns. A stainless steel  $\frac{1}{2}$  shell clamp system was developed to provide this additional protection for the tow cables and air line. This addition to the guns has extended the useful life of the connections and reduced the chances of damage to the solenoid, time break sensor and air fitting. These clamps can be seen in Figure 4.10.

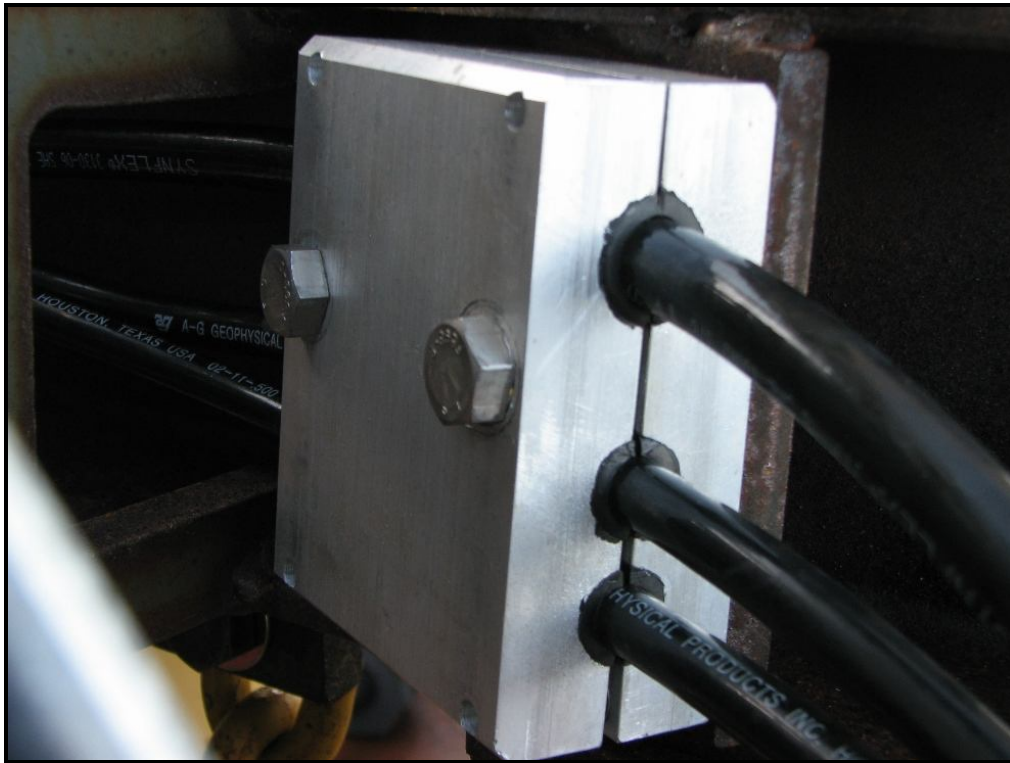


**Figure 5.10 10 520 cubic inch gun with collar protectors fitted.**

A hardware refinement completed for the 2008 program was the improvement to the break out blocks which secure the solenoid firing, and time break lines and the air line to the tow sled. There are three such blocks mounted on the sled, each mounted above and aft of the guns. In 2008 the blocks were redesigned, making it far less time consuming to mount the hoses and electrical lines to the sled. Figure 4:11 clearly shows the newly designed break out block.

The two lengths of  $\frac{5}{8}$ " grade 80 chain used to suspend the forward gun from the gun cradle were shortened by two links in 2008. This served to reduce the chances of damage to the forward gun's electrical lines and air hose due to contact with the spreader bars on the aft guns. The change did not impact the performance of the gun array.

The electrical cables from the aft G-gun solenoids were slightly damaged after considerable deployment time. These electrical cables were judged to be too short and therefore stressed at the point where the potting ended at the head of the cable. In future deployments the solenoid and time break electrical lines and the Synflex air line will be lengthened to reduce the chance of damage.



**Figure 5.11 Modified break out block as fitted in 2008.**

### **G-Gun Source Calibration**

Midway through the seismic program a gun calibration was undertaken to determine signatures and peak power of the Sercel G-guns. An IKB calibrated hydrophone was lowered to a depth of 400 feet below the gun sled. The actual position of the deployment point of the cal phone was 13 feet to port and 6 feet forward of the tow sled pull point. Each gun, and various combinations of the three fitted gun were fired. The resultant gun signals were recorded onto GSCDIG #4 to a total of nine separate files. The calibrated hydrophone was then raised to 200 feet below the sea surface and several more measurements were made. Typically each file contained a maximum of 15 separate shots.

During tests, the tow sled was at a fixed tow depth, approximately 33- 34 feet and the ship was stopped. The two aft guns were 5 feet below the tow sled pull point, making this depth 38 feet, the forward gun 4 feet below the sled pull point, making this depth 37 feet.

For some of the G-gun shots the time break signals were not perfectly synchronized. It is believed that this was due to icing in the guns. Effort was made to ensure enough shots were recorded to provide at least 2- 3 well synchronized gun signature patterns for the various combinations of the three guns.

On the final day of tow sled deployments another attempt to perform a gun calibration was made. The Port tow sled was deployed without the GeoEel streamer. Initially there were problems with ice in the air lines from the compressor. This was cleared with some effort by heating the "T" connection point between the port and starboard compressors. Later ice blockage occurred at the air manifold was again the icing condition was cleared using heat.

Once the guns were initially fired the calibration hydrophone was lowered to a depth of 400 feet. Several shots were fired using all three 520 cubic inch G-guns. Gun synchronization was a problem from the offset. After approximately 10 shots the signal gain from the IKB system diminished. This was the identical fault with the IKB system which was experienced in 2007. For this reason no further calibration attempts were made. The gear was recovered without completing the final calibration.

It is hoped that enough shots were collected before the gain change in the IKB preamplifier occurred.

Calibration data collected will be independently analyzed and a report generated.

### **5.3.2 Compressor and air distribution system**

The total volume of the 3 Sercel G-guns used for the 2008 UNCLOS program was 1190 cubic inches, 2- 520 in<sup>3</sup> guns and 1- 150 in<sup>3</sup> gun. At a maximum shot rate of 8 seconds, the air delivery system must be capable of supplying 6545 in<sup>3</sup> of compressed air per minute which translates roughly into 400 SCFM at a pressure of 1850- 1900 PSI. To this end, in 2006 NRCAN, GSC (A) procured two Hurricane Compressors, Model 6T-276-44SB/2500. These are air cooled, containerized compressor systems. Each compressor is powered by a C13 Caterpillar engine which turns a rotary screw first stage compressor and a three stage piston compressor capable of developing a total air volume of 600 SCFM @ 2500 PSI.

The compressor enclosures were welded to the ship on specially fitted structures that have now been designated as "boat deck extensions", on both the port and starboard sides next to the hangar. The starboard side extension was added during the winter of 2007 and the port side, in 2008. These structures accommodate the 12' x 20' containers housing the compressors and allow walkway access to the inboard side and forward end of the compressor container where man doors are fitted. Total weight of each enclosure is approximately 11.5 tons.



**Figure 5.12 From flight deck showing both compressor containers as fitted in 2008.**

Fuel for the diesel compressors was supplied by the ship. A record of all compressor status readings is included in Appendix B of this report.

The Hurricane compressors were able to supply the necessary air for the seismic program. As extensive repairs were carried out through the 2008 winter season on HC#1 compressor, technical personnel felt it best to run this machine as the primary pumper, leaving HC#2 to serve as a backup machine, only in operation during HC#1 repair periods. Again this year the HC#1 machine initially required an inordinate amount of service. Once repairs and modifications were completed on HC #1, the equipment performed satisfactorily.

### **Air distribution**

The high pressure air generated by the compressors was fed into a 1" delivery pipe that ran from the starboard side air compressor to the forward bulwarks, starboard side of the quarterdeck. At this location an air dump valve was fitted to allow operators to "blow down" the air pressure in the pipe and blow off any accumulated moisture. This process was done on a regular basis to ensure that there was minimal water lodged in the pipe. The tank rack and air manifold was fed from the 1" pipe at this point.

### ***Reservoir cylinders with start-up problems***

The reservoir cylinder and air manifold system (called the "tank rack") provided individual monitoring and control of high pressure air to each Sercel G-gun. The air manifold was equipped with a check valve on the supply side. Initially two identical systems, one for port side and one for starboard were fitted to the quarterdeck of the vessel.

Four air "T -size" reservoir cylinders were removed from the tank racks in late 2007 and sent for recertification. The test facility did not return the original four tanks, but replacement tanks of the same T-size and pressure capacity. Unfortunately technical personnel did not have an immediate opportunity to reconnect these cylinders to the tank rack. Onboard the LSSL, attempts to connect the air lines to the cylinders were made. At that time it was discovered that the  $\frac{3}{4}$ " female pipe threads tapped into the top of the four cylinders were all undercut very badly and a standard  $\frac{3}{4}$ " NPT nipple would not fit securely into the top of the cylinder. An attempt was made to weld pipe nipples into the top of each cylinder. Small leaks in the welds became evident when the cylinders were pressurized. This posed a safety hazard and the four cylinders were condemned.

Two empty T- size cylinders were located on the vessel, one an original GSCA air cylinder (yellow), a second, an empty oxygen cylinder. The two replacement cylinders were mounted into the starboard tank rack. The port side tank rack was decommissioned for the entire trip. For operational purposes, it was necessary to connect the port sled airlines to the starboard air manifold for port sled deployments. This did not pose any significant problem throughout the program.

Air leaks in two dump valves were repaired by valve replacement during the program.

### ***Backpressure valve***

A back pressure relief valve was installed in the air distribution system. The valve was mounted on the inner bulkhead of HC#1, the starboard compressor, but was linked to both compressors by a  $\frac{3}{4}$ " common Synflex air line (see Figure 4.13).



**Figure 5.13 6000 SCFM back pressure valve as fitted to HC #1 container bulkhead.**

The purpose for this valve was to dump surplus high pressure air to atmosphere through a dump line located above the HC #1 container.

To set this valve: (1) both compressor Barksdale switches were set to cause the compressors to auto-unload at 2100PSI, (2) the back pressure valve was then adjusted to open at 1900PSI. Thus, when making air, either compressor ran at full capacity. This prevented the machines from auto-unloading every minute as was the case in 2007 resulting in constantly changing loads on the machines.

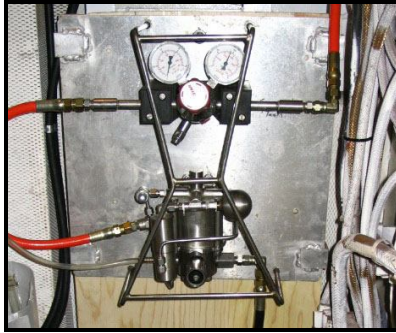
On the quarterdeck, the tank racks also served as connection point where the electrical lines from the bundle mated to the firing control lines running from inside the seismic lab. Figure 4:14 shows the internal wiring of the starboard junction box. The box connections points allow the technician access to the electrical lines running to the tow sled. Here continuity and resistance measurements can be made to check gun electrical performance for each gun. Two boxes were located on the quarterdeck, one for each sled.



**Figure 5.14 Electrical junction box for starboard sled showing internal wiring.**

### ***Antifreeze Injection System***

Throughout the seismic program gun freezing was a constant issue. To reduce the affect of freezing water in the air distribution system, an antifreeze injector pump was employed to introduce bio-degradable antifreeze into the high pressure air system. This antifreeze is sold under the brand name of "NoTox2" and is safe to use in high pressure air delivery systems such as aboard the vessel.



**Figure 5.15 Antifreeze injection pump.**

The injection system used control air of 80- 100 PSI from the ship's domestic air system, to operate a pump that drew small amounts of antifreeze into the pump's pressure chamber. At timed intervals, an injector piston forced open a check valve pumping antifreeze into the G-gun air reservoirs. The timing cycle of the injection could be adjusted from several seconds per cycle to 1.5 minutes. This finite control was accomplished using a small needle valve adjustment which controlled the amount of air pushing on the injector piston. It was determined, by trial, that a 45 second cycle rate was optimum. This worked out to 2- 3 G-gun shots for every injection of antifreeze. It is estimated that at an injection rate of 1 pump every 45 seconds, the program used approximately 30 gallons (130 liters) of NoTox2 antifreeze over the 6 week period.

It was suspected that the majority of ice built up in the air distribution system originated in the 175 feet of 1" steel line that ran from the compressor to the quarterdeck and the excess Synflex lines from the air manifold to the gun bundle. This posed a logistical problem as temperatures dropped to -10° C and below. The worst ice up condition seemed to occur after the first shot of the G-gun following deployment. If the air was not flowing through the system continuously, ice would form very quickly. To reduce the incidents of icing a Herman Nelson type of heater was used to continuously pre-heat the G-guns before deployment. Also prior to any deployment, the air 1" line from the compressors and the three air lines to the sled were "blown out" using high pressure air. When the G-guns were first fired, the centre gun was always fired first. Historically it seemed to be less susceptible to freeze-up.

Incidents of gun freezing were all but eliminated in 2008 using these methods (see Figure 4.16).



**Figure 5.16 Herman Nelson-type heater supplying a steady flow of warm air to the port sled system.**

### **Specific issues related to the Hurricane Compressors**

The first Hurricane air compressor (now designated as HC #1) was purchased by NRCan in the late fall of 2006. This compressor was chosen for three prime reasons:

1. Price: The compressor was priced at about 30% of the cost of an equivalent marine system of similar capacity, even after the cost of spares and a suitable enclosure were factored in
2. Air Cooled: The machine does not need any ship board services except for electrical connections for enclosure heat and lights. It utilizes fan cooled intercoolers for each stage of the compressor
3. Capacity: the Hurricane compressor is capable of producing 2500 PSI air pressure at 600 SCFM, sufficient for the seismic program on LSSL.



**Figure 5.17 Hurricane Compressor, (HC #1), fitted to the starboard side of LSSL.**

The air required to cool the compressor is taken in through louvered ducts on the inboard side of the compressor enclosure. The air is then pushed out the aft end of



the enclosure through the Caterpillar diesel engine radiator and through air and oil coolers on the John Deere pumper and onto the plenum fitted on top of the roof (see figure 4.17).

During much of the program the ambient air temperature was below zero degrees Celsius, and with the high air flow rate through the enclosure, this created an extremely uncomfortable working environment for the operator. Wind chill became a real issue and concern. It was learned through trial and error, that the inlet and exhaust louvers could be regulated to somewhat improve the operator comfort level inside the enclosure.

Similar issues to those described in the 2007 report were experienced again in 2008. Considerable time and attention was given to addressing problems brought on by excessive vibrations and misalignments in the compressor "plumbing". Installation of support structures, all custom manufactured, helped to reduce compressor break downs.

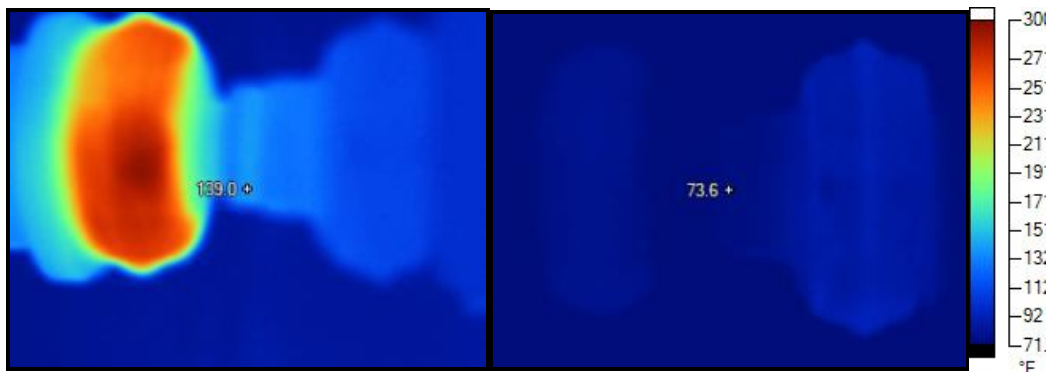
A number of brackets and supports were fabricated and fitted to key areas where vibration was causing performance and/ or safety issues. Most of these were in areas where watch keepers suspected problems might occur. Some problems were as a result of welding fatigue caused by vibrations and/ or simply poor design on the manufacturer's part.

Particular areas on HC #1 that were addressed in 2008:

1. Discharge air line from the rotary screw compressor - excessive flex in pipe causing oil leak at coupling. For this a custom support bracket installed
2. Fourth stage air discharge pipe coupling failure - designed and machined new fitting and installed hard piping
3. Drive shaft replaced due to a U joint failure. Note: It was learned by trial that a minimum of 25- 30 shots of grease, into each nipple, is required to "charge" a new U joints before being put into service.
4. Fourth stage safety "pop valve" was fitted with custom support bracket to reduce vibration and possible failure
5. Second stage supply air line support bracket (top of compressor frame near 3<sup>rd</sup> stage moisture separator tank) was removed, repaired and reinforced after weld failure and reinstalled
6. 1<sup>st</sup> stage thermo-bypass valve: support bracket fabricated and installed. This was suspected as a failure point due to excessive vibration at this location
7. Air discharge pipe nipple (out of the top of the separator tank) failure: Part of the pipe running from the air/ oil separator tank to heat exchanger. Cracked due to vibration/ metal fatigue on the thread of the pipe nipple. Welded and reinstalled
8. Mounting bracket on the air/ oil separator tank- caused tank failure. Weld broke through the tank causing air/ oil leak
9. Misalignment of piping from the 1<sup>st</sup> stage air line to the 1<sup>st</sup> stage air cooler; coupling installed and re-welded to reduce stress
10. 2<sup>nd</sup> stage inlet tank on top of the J-D pumper developed a leak. Tank was welded
11. Site glass on the air/ oil separator tank failed. Bypassed with 6" pipe nipple. Part required.
12. Electrical wiring issue with compressor shut down: Shorted electrical wire caused unexpected and extremely intermittent shut down of the compressor. Wire was redressed.

13. Re-drilled and re-tapped drive shaft shroud to allow all hardware to fit as designed. There were two holes that had been miss-drilled in the shroud, from the factory, and bolts could not be used in these holes to secure shroud to Cat engine.
14. 3<sup>rd</sup> stage discharge head coupling: Weld cracked leaking 800PSI air at 250 degrees F. Piping was removed and coupling repaired. New brackets were fabricated to permit better alignment of piping from JD head to the 3<sup>rd</sup> stage heat exchanger inlet.

In 2008 NRCan purchased a Fluke digital thermal imaging camera. This camera was used throughout the seismic program to observe and monitor air compressor functions. The failure of the drive line U joint was clearly documented over a short period by the technicians on watch. Figure 4.18 shows the U joint as the temperature rises to almost 300 degrees F. Also shown is the image of the replacement U joint after installation.



**Figure 5.18** Fluke digital thermal image of drive line U joint. The left image shows the joint heating to nearly 300°F during use. In the right image, the U joint has been replaced.

## Summary

Most of the problems experienced during the operation of HC #1 compressor were sorted out over the program period.

During the program there were two incidents of a damaged air lines on the tow sleds. Both times the connector on the end of the Synflex air line separated from the hose. This problem was addressed when the USCGS Healy science crew delivered correct 3/8" Synflex press hose dies to the LSSL. After proper hose connections were made, no further air hose issues arose.

Heat tape was fitted to key points on both Hurricane air compressors and associated air line connections inside the compressor containers. The air dump line on the back pressure valve was a particular concern as the large pressure drop across the valve causes a dramatic drop in the discharge air temperature at this location. For the first several days of the program the Fluke IR temperature probe was used to monitor key locations in the discharge line from the backpressure valve to ensure no air blockages occurred due to water freezing in this line. Heat tape was wrapped specifically around the base of the valve and the elbow at the base of the discharge

line (at floor level) inside the compressor container where temperatures were monitored to be at or below freezing, especially if HC #2 was on line.

The Sercel G-guns performed extremely well with no incidence of time lost due to gun mechanical failure. Gun icing issues were addressed in 2008 and a work-around to this problem was developed and proved successful.

The overall performance of the air distribution and tow sled system was judged satisfactory.

### 5.3.3 GeoEel Digital Seismic Streamer and Deck Handling System

#### System Description

The Geometrics GeoEel digital streamer system was used throughout the survey to acquire seismic reflection data. The streamer was towed from the aft end of the tow sled at a depth of 34 feet. Two active 150 foot streamer sections were included in the overall streamer configuration. Total streamer length was approximately 930 feet. Two identical streamer systems were assembled for the 2008 program and were deployed and recovered using the newly installed winches shown in Figure 4.19.

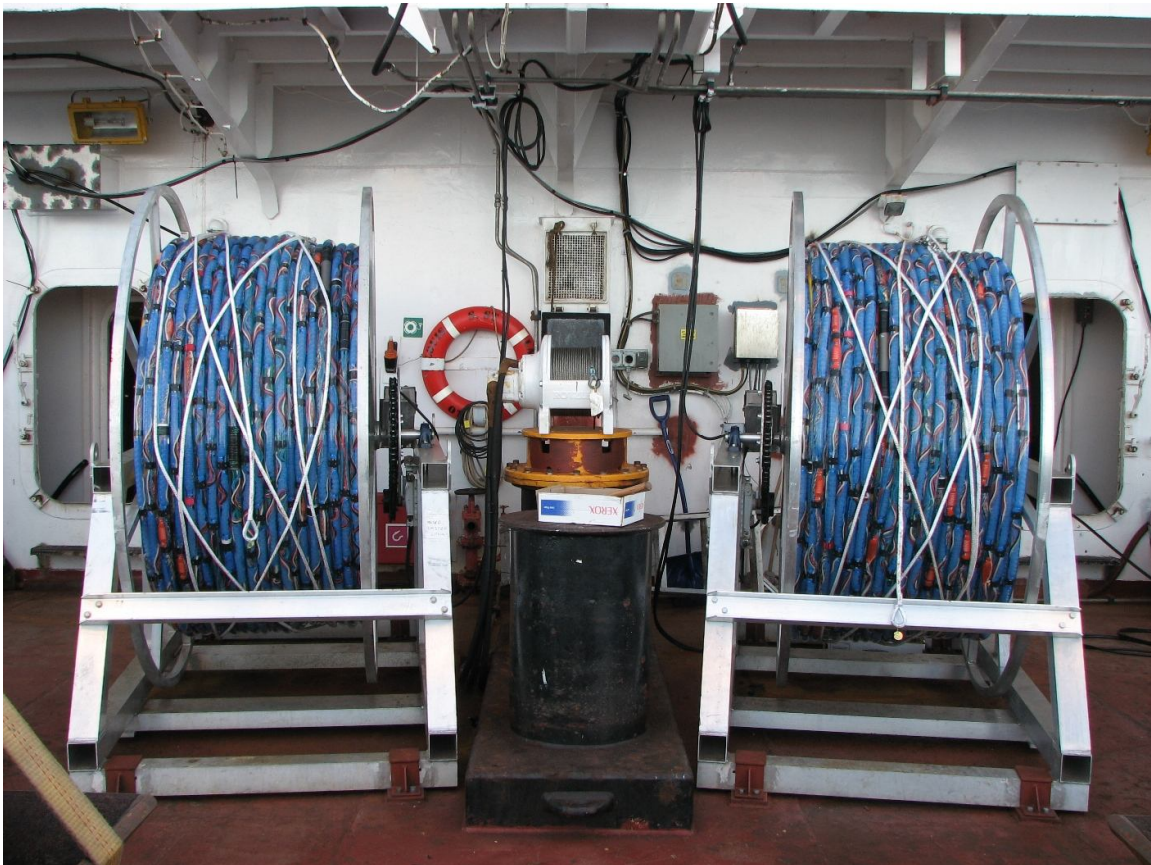


Figure 5.19 Two GeoEel streamer winches fitted in 2008.

The active elements in the GeoEel streamer were Benthos Geopoint hydrophones. There were eight groups of four Geopoint hydrophone cartridges in each active section. Thus, with two active sections, this streamer had a total of 16 active channels, each with four Geopoint cartridges. Seismic signals received by the hydrophone elements in the streamer were digitized by 24 bit A/D modules which form part of the streamer system. A log of the various configurations for the GeoEel systems is included in Appendix D of this report.

The digitized seismic signals were sent up the cable as data packets to the acquisition system. A Geometrics software program called Stratavisor provided streamer control, logging and display of the data.

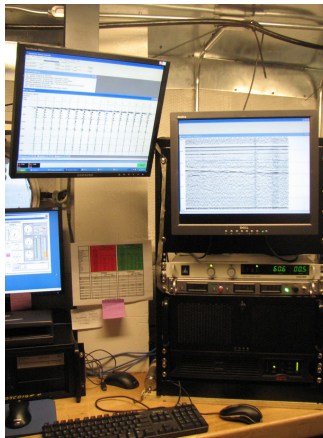
Included in the Stratavisor software was a streamer depth monitoring option. Depth sensors were fitted inside the forward end of each active section. The active section tow depth was displayed on the Stratavisor monitoring software. On one occasion the vessel was stopped by ice and the streamer slowly sank beyond the operational tolerance of the transducers. This caused permanent damage to the sensors in both active sections of the starboard streamer. There was no depth data available for this streamer after that incident 100' of Nylon tail rope was used to reduce streamer vibrations and keep good tension on the array while being towed.

No drogue chute was used during the 2008 program.

**Table 5.1 The GeoEel Deck System as fitted, 2008.**

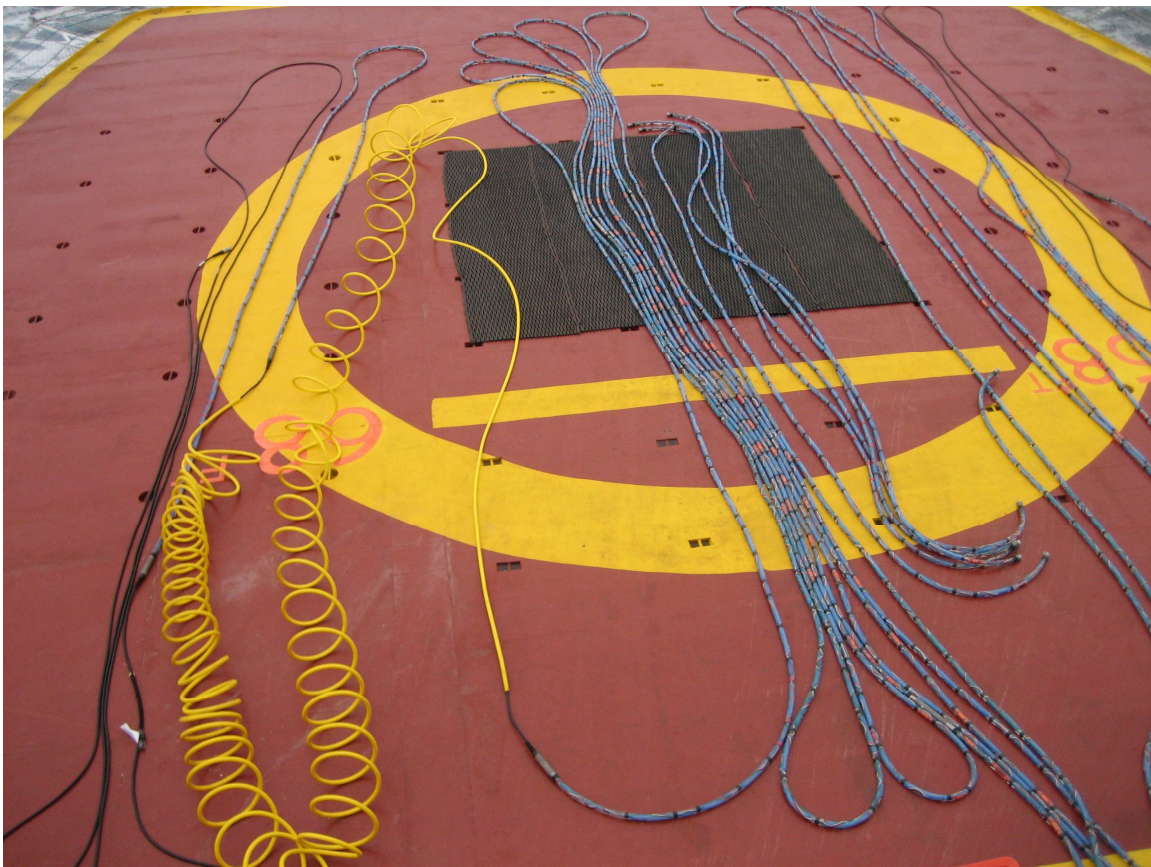
- Rack enclosure
- PC-based 3.00 GHz computer with 2 GB memory, 2x500 GB hard drives
- Geometrics Stratavisor NX Version 4.51 Operational Software
- Geometrics GeoEel SPSU Deck Control Unit with aux/depth
- Xantrex XFL 60-20 DC power supply unit
- APC Smart UPS 2200 battery back-up unit
- Lab-to-deck cable – SN DC01063 – 25m

During the 2008 survey, problems arose with the GeoEel Stratavisor software. It is believed that there may be bugs in the software package causing some Windows Registry entries to become corrupt. To cure the software problem, the entire operating system from the spare GeoEel PC was transferred to the damaged GeoEel PC hard drive. This restored the system to operational status and it was returned to service. At the completion of the repair, both system hard drives were ghosted onto DVD. This will provide operator rebuild capability if additional software problems develop in the future.



**Figure 5.20 GeoEel Deck System in the LSSL Seismic Lab, 2008.**

There were some operational problems during the first several days of surveying. The small fill and port screws on the end collars of the streamer sections were found to have become quite loose. This caused water ingress into the streamer fluid on several sections as noted in Appendix D. Replacement sections were used and the damaged sections will be returned for service to the manufacturer's facility.



**Figure 5.21 Digital Streamer System "unboxed" on the Flight Deck of LSSL.**

A GeoEel armored deck cable was included within the cable bundle lines for both Port and Starboard tow sleds. A Kelleem Grip, affixed to the inboard end of the yellow flotation jacket was attached to the point tow bridal which was secured to the rear of the tow sled. This served as the streamer tow point.

Each streamer connection was tightened using the tool provided by Geometrics, cleaned, and taped over using 3M Scotch 130C Splicing tape, 3M Scotchkote Electrical Coating, and 3M Scotch Super 88 Vinyl Tape. As per Geometrics suggestions, the oil filling screws and set screws were checked for tightness and covered by the tape.

The overall length of the streamer aft of the tow sled was approximately 930 feet including 100 feet of Nylon rope.

The Stratavisor software running on the deck PC communicated bi-directionally with the active streamer components (A to D modules, repeaters, and auxiliary channels for depth measurement devices) via a UDP data string similar to that used in a standard PC networks.

The Analog to Digital Converter Module located at the inboard end of each active section was assigned a designated IP address during Stratavisor software setup. The deck PC keeps track of the location of the individual A/D converters in this manner. The A/D module converts the 8 hydrophone analog channels into a UDP digital string which is sent through coaxial cable located within the streamer cable bundle to the lab PC.

There are repeater modules placed at distances not more than 300 feet apart throughout the length of the streamer cable including one on deck between the lead-in cable and the inboard end of the inboard end of the tow cable bundle.

## **Issues arising with the GeoEel System**

Most of the difficulties arising with the streamers in 2008 were as a result of seawater ingress into various streamer sections or connectors. The small filler screws located at both the inboard and outboard ends of the streamer sections loosen during deployments or were found to be loose from the manufacturer. It was also learned from experience that the connectors used to couple streamer sections and A to D and repeater modules together would also loosen during deployment.

Due to these repeated issues, extreme care was exercised to ensure that each section was inspected, tested and repeatedly tightened. The electrical insulating product called Scotchkote was used to carefully coat the screws and connectors once they were inspected for tightness. A layer of rubber vulcanizing tape was then applied, next a second coat of Scotchkote was added. Finally a layer of 3M cold weather electrical tape was added over the Scotchkote.

Final deployments for the streamer were actually quite acceptable after these checks were implemented.

After one deployment the deck cable (inside the pull bundle) and the flotation cable were badly damaged due to twisting of the two cables. It is believed that this damage occurred as a result of deploying the streamer in a very small ice lead, less than the overall streamer length. When the streamer was deployed a number of

twists occurred in its overall length and as the stress of towing increased, damage to these sections occurred.

Two sections of the streamer which were repaired as a result of 2007 damage did not function well on first deployments. One active section had a bad analog channel (channel 7) and the deck cable (inside the cable bundle) had immediate high leakage after the first 12 hour deployment.

Appendix E contains the detailed historical record of streamer configuration and performance for the 2008 UNCLOS program.

### 5.3.4 Sonobuoy System

#### System Description

Two Winradio VHF sonobuoy receivers were installed in the radio room on board the vessel. An Andrews DB292-C VHF antenna, cut to respond to frequencies between 150 and 160 MHz, was fitted to the aft railing on the port side of the crow's nest. Suitable coaxial cable was run from the crow's nest into the radio room to couple antenna to receiver (see Figure 4.22).

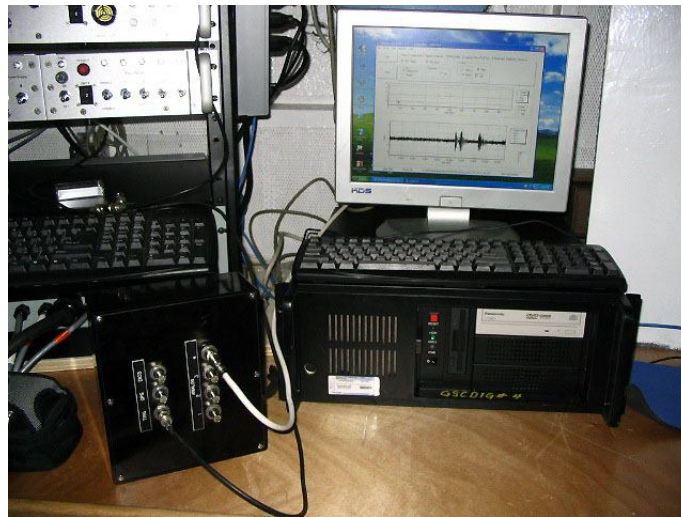


**Figure 5.22 Sonobuoy antenna as fitted in 2008.**

All Winradio receiver functions were controlled by manufacturer's software running on a laptop PC in the seismic lab. RS232 to UDP converters were used on both ends of a dedicated pair of fiber lines running directly from the radio room to the seismic lab, connecting both the laptop PC and the Winradio receiver.

A single RG-6 coaxial cable was run from the ship's radio room to the seismic lab. The RG-6 coaxial cable carried the sonobuoy analog signal output from the Winradio receiver to the GSC\_DIG #4 data logger, channel #1, located in the seismic lab. During the program Winradio receiver, Serial No. 016117, failed. It is believed that the helicopter DF beacon, which operates in the HF radio band, saturated the front end of the receiver and damaged sensitive circuitry. This receiver was one of the original two units received from Ultra Electronics when the sonobuoy system was purchased in 2006. Last year (2007) the first receiver was damaged and sent to the manufacturer for a replacement exchange. When they exchanged the unit, the new receiver was not equipped with the same external connections. The DIFAR output, available on the original unit, was not fitted to the replacement receiver. To work around this, NRC staff made up an adapter to connect the GSC\_DIG #4 data logger to the audio output stereo jack on the rear of the Winradio receiver (see Figure 4.23). This functioned, but did not provide the quality signal received from the original two units.

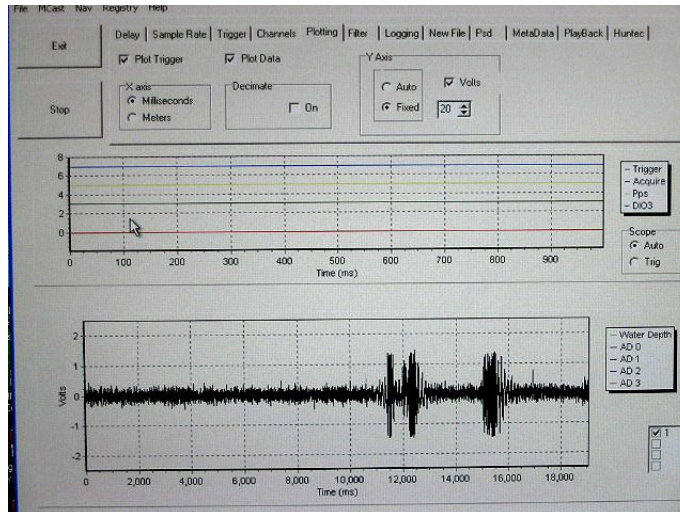
Prior to the 2008 seismic program, GSC\_Dig #4 was sent to a calibration facility and was recalibrated to confirm system performance.



**Figure 5.23 GSC\_Dig #4 Data Logger setup in the seismic lab on LSSL.**

Analog data from the Winradio sonobuoy receiver was input to channel one of GSC\_DIG #4, digitized by the 24 bit A/D card and logged to hard drive. Typical digitizing periods were 12 to 20 seconds with maximum sample rate typically 290 Hz. The digital acquisition trigger was provided from the Frydecky timing control box. Navigation data was recorded as part of the SEG-Y header file.





**Figure 5.24 Sonobuoy record displayed on GSC\_DIG #4 at range of 10 miles.**

## Summary

The radio link between the sonobuoys and the vessel was better than predicted by the sonobuoy manufacturer. With the height of the fitted receiving antenna on the vessel of approximately 80 feet, it was expected that ranges of 8- 10 miles would be the norm. In some cases reception extended to 15- 20 miles.

Winradio receiver, Serial No. 016117, failed after suspected HF RF energy damaged the receiver front end circuitry.

Standard procedures for sonobuoy deployments were adopted:

1. Transmit frequency for the buoy was originally set to 156.250 MHz, Channel 86 then lowered to 155.700, Channel 85 midway into the program
2. Standard Hydrophone depth was set to 60 meters (D2)
3. Standard sonobuoy RF transmission duration was set to 8 hours
4. The Winradio receiver must be shut off during helicopter operations to prevent radio front end damage believed to be caused from the ship's HF helicopter beacon.
5. No sonobuoys were deployed during helicopter operations

Initially, a high failure rate for the sonobuoys occurred. It is now believed that the buoys were likely functioning, but that the problem was actually the Winradio receiver being flooded with HF energy from the helicopter beacon.

At the end of the survey the sonobuoy antenna was removed from the crow's nest and inspected for wear and tear. At that time the coaxial cable running from the radio room to the antenna was measured; it showed no leakage and is considered functional. As the antenna was being serviced for winter storage, water was seen leaking from the sealed termination box where the coaxial cable exits the dipole. This was a concern and perhaps the reason for the apparent Winradio receiver malfunctions of 2008. New antennas will be purchased for next season's program.

During this 2008 program a total of 39 sonobuoys were deployed with data collected from 37 instruments.

Appendix D contains a list of deployment times and line numbers for the Sonobuoys deployed in 2008.

### **5.3.5 Data Distribution about the vessel**

One 2007 recommendation acted upon in the spring of 2008 was the installation and upgrade of the data network on the vessel. The system, prior to 2008, was a combined science and Coast Guard network. It was a fiber system based upon a 100mBit/second transfer rate with limited DHCP capability.

To enhance this network it was decided to separate the science and CCG networks entirely. This would provide three major improvements:

1. Increased security for the CCG internal system, specifically for navigation and engine room control, by completely isolating this equipment from the science network
2. Improve the overall speed of the system for file transfers etc.
3. Network control for key pieces of equipment which are not used CCG, like NRCan sonobuoy Winradio receivers and network printers.

This work was carried out in the late spring and the new system has proved to meet all the intended goals. The cost of the upgrades, slightly over \$110k, was shared by UNCLOS, DFO Science and CCG.

## **LSL 2008 Navigation and Data Distribution and Processing**

The data streams required by the various systems in operation in the seismic lab were provided through dedicated fiber connections from the bridge and the forward lab. Differential GPS navigation was provided by the science Novatel receiver. NMEA sentences from this system were multiplexed to the ship's speed log and gyro NMEA sentences and distributed to the seismic lab via a newly installed dedicated fiber connection. The bathymetry was distributed to the lab via a dedicated fiber connection from its location in the forward scientific lab. The information received from the bridge was again multiplexed with the bathymetry in the lab in order to get all this information to the seismic logger which will only allow one serial input feed. The Regulus navigation system, running Build 28894 version of the software, was used to view and log the scientific navigation. The Regulus system was also used to view and update the electronic log.

Some inconvenience was encountered due to a problem with the Regulus navigation system which causes it to slow down over time. Regular re-starting of the program appears to correct the problem although a full system reboot was undertaken. The navigation data were cleaned and merged using a text editor and the standard GSCA programs ETOA, INTA and APLOT. Raw E-format, raw A-format and cleaned and edited 10 second A-format files were saved on a daily basis and transferred to CD for GSCA archiving. All seismic and sonobuoy data as well as their related log files were also backed up to DVD for archiving. In addition, the compressor watch keepers and mammal observers maintained paper records of their observations. These were reviewed on a daily basis and transferred to digital spreadsheets.

Following recommendations stemming from last year's survey, the ship's network infrastructure was restructured and improved. A new 1Gbps backbone was installed; a new 24 core fiber connection was installed between the Seismic Lab and Bridge/Radio Room and a 12 core fiber connection between the Seismic Lab and the Forward Lab. The network itself was restructured into two networks, ship and science. The new structure has made possible the separation of ship and science network activity and IP address structure. Not only does the reduced traffic on each network increase the overall efficiency of both networks but the ability for the science programs to work within their own IP space has greatly improved their ability to work within the flexible and responsive network environment they require. The direct feed of the navigation and bathymetry through these new fiber drops has resulted in a flawless operation with no data interruptions or loss of the Knudsen sounder due to data communication problems. The fiber drop was used successfully for the serial control of the sonobuoy receiver in the Radio Room from the Seismic Lab. The only problem encountered was an extremely slow link between one of the cabins and the Seismic Lab. As this connection was to be used for a very high volume of data transfers the problem was quite serious. The problem was traced to a duplex mismatch between the cabin's media converter and the port it was connected to on the switch.

A network radio link was installed by the technicians from the USCGC Healy to provide communication between the two ships over an IP phone connection for the benefit of the science program. Although the system did work, it did not meet expectations as the range was limited to 1.5 to 2 nm. It had an expected range of 8 to 10 nm. More work will be done over the winter by the Healy technicians to identify and correct the problem. Two phones were installed, one in the Radio Room and another in the Conference Room. In order to isolate this network from the ship and science networks, the network connection to the phone in the Conference Room was accomplished by patching the radio link's computer directly to a network receptacle in the conference room via the Forward Lab and After Lab patch panels. Some problem occurred in installing this link as the link between the Radio Room and the Forward Lab was mislabeled and it took some time to identify this, and the first link attempted between the After Lab and conference room turned out to have a fair amount of signal attenuation impeding the communication. This again took some time to discover.

## Recommendations

- A complete check of all the fibre connections between patch panels should be undertaken to ensure that they are correctly labelled. A complete check of all the network drops should also be undertaken to ensure a proper duplex match between the media converters in the cabins and the port they are connected to on the network switch. Considerable time was lost because of these two problems as one would not expect to encounter these on an established network.
- ICAN, the developers of the Regulus navigation system, should be approached concerning the apparent problem with memory management. Although this could be a problem with the computer memory, this is not suspected as the problem is a persistent one across computers. The problem appears connected to the amount of information displayed on the screen and the

length of time the program has been running. The problem becomes apparent with the slow response to user commands and the irregular updating of the time display. The ship icon on the button used for centering the display also disappears although the buttons still work.

- Network receptacles should be installed at locations close to the compressor containers for more convenient connections to the compressor telemetry systems. If the starboard science containers remain on board and access their network switch is available, this would be adequate for the starboard compressor. The port compressor, however, needs a closer receptacle as the long run to the science container is excessive. Perhaps a receptacle in the helicopter workshop or emergency generator room would be possible.
- There is a need to allow some communication between locations on the science network and on the ship network. Presently, access to the Shipnet e-mail is the only one allowed. A cross network connection would be needed to allow the display of the compressor telemetry in the engine room. This would allow them to more efficiently monitor fuel needs and respond to them in an efficient manner. As not all science personnel require to be on the science network as they have no need to communicate with other science computers, there is a also very limited need to access the HP5500 printer from the ship's network. Other needs, again very limited, could also arise from the various scientific activities carried out on the ship. This could be accomplished by IP address to IP address routing. Again, the need is necessary but limited and the connections should only be allowed with the chief scientists and ship's technician's consent. The ship's technician should be aware of how this can be accomplished.

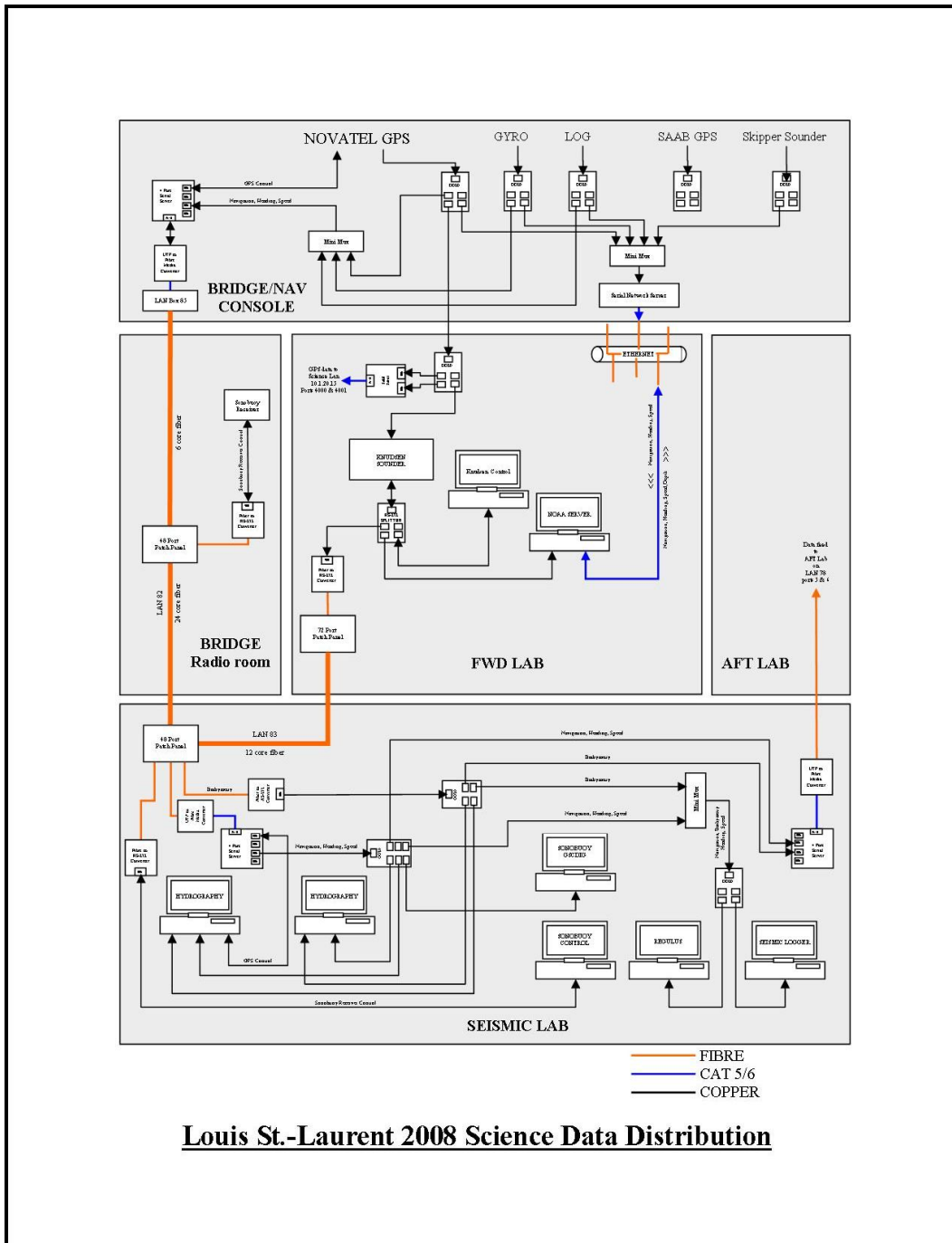


Figure 5.25 Pictorial Schematic of the new Science Network as fitted to LSSL in the spring of 2008.

### 5.3.6 Recommendations for future technical work:

1. better method of keeping track of streamer configuration, spares and configuration changes
2. assign two people to administer the streamer configuration throughout the program
3. asses damage to streamer components due to water ingress and establish a written service procedure for servicing same to prevent this from occurring in the future
4. an air supply, portable or otherwise, located in areas where the streamer service will be performed
5. obtain list of manufacturer's approved chemicals which can be used on the streamer components
6. suggest ways to allocate more time to complete repairs and not feel rushed
7. source of Dow 111 silicon grease in an easy dispenser to prevent contamination
8. supply of Kimwipes
9. check supply of all "O" rings used including the "square rings in the A to D module connectors
10. investigate "T" tank of Nitrogen and regulator to displace the moisture around and inside the streamer connectors
11. purchase a second streamer deck lead-in cable
12. check for a power supply cable for the spare streamer control unit
13. investigate better labeling system for the streamer sections and modules
14. new keyboard for the GeoEel computer
15. investigate a purchase of an UPS for the computers in the seismic lab
16. convert all control relays in the streamer winches to 24VAC
17. investigate better directional change switching system for streamer winches
18. install more cross bracing on the forward end of the streamer winches
19. repair weld on starboard winch hub (outer weld)
20. look at a sheer pin arrangement for the winches to prevent overstressing the drive system
21. install grating instead of solid decking by the winch controls
22. locate the start/ stop station for the 50 HP power pack at the winch operator's station
23. paint markers on the streamer winch and tugger winch drums to allow visual indication of winch rotation
24. install bracket on the stainless steel hydraulic line located on the quarterdeck to reduce vibration in this line
25. fabricate a better tank for the antifreeze pump that will allow operator to see tank level
26. purchase standard paint filters to filter antifreeze as it is added to the antifreeze tank
27. purchase brush cleaning kit for cleaning the G-guns
28. fabricate a "lazy Susan" for turning streamer boxes on deck
29. look at better saddle brackets for the air and electrical lines on the tow sled
30. look for a better "tent" arrangement for the tow sleds
31. investigate a better method of routing the streamer armored cable at or around the tow sled
32. investigate a better way of protecting the electrical wires and air hoses where they pass through the top of the tow sled

33. micropress collars on the pull cables instead of the bulldog clamps
34. install emergency lighting inside the compressor containers and the workshop
35. install fire bell and light inside containers hooked to the ship's system
36. install an A frame camera
37. moisture separator tanks on each compressor and one at the quarterdeck
38. move the T which combines the air supply from the two compressors into the HC #1 container and heat with cord
39. Nytrol gloves for personal hand protection when working with chemicals
40. recommend that all network drops located about the common areas of the vessel are checked and correspond to the appropriate line numbers at the switches
41. check with ICAN re problem with Regulus memory usage and for available upgrades
42. discuss HC interface through the science network
43. investigate Engine Room display of HC data and also for seismic lab
44. upgrade vents on port HC to ones with rubber seals
45. ship's telephone in workshop container
46. purchase trouble lights for workshop and HC's
47. set of larger wrenches for the HC's
48. toolboxes for HC's
49. welder outlet (220VAC single phase) on the quarterdeck
50. HP flex couplings on compressor, what's available
51. install better support system for the oil separators on the HC's
52. install better discharge valve on the 1<sup>st</sup> stage moisture separator
53. purchase cap screws for U joint
54. purchase new U joint
55. have the defective U joint replaced on drive shaft
56. U joint press
57. strap wrench or chain wrench for oil filters on the Cat
58. battery blankets for the G-guns
59. additional 110VAC outlets by A frame and bulwarks on the quarterdeck
60. jerry cans with visible site glass
61. diesel fuel supply located in the Av Gas area
62. purchase supply of A to D and repeater floats from Geometrics
63. inquire about a redesign of the depth sensors for the GeoEel
64. swappable HD system for the GeoEel system
65. replace all HD's in the lab PC due to damage from excessive vibration
66. investigate getting the depth sensor data out of the GeoEel Stratavisor software so it can be logged
67. install foam around the streamer drum cross braces
68. remove or reposition railing on the port side to improve access to HC #2
69. remove air duct on inboard bulkhead of the HC #2 container and reposition the HC #2 control PC onto this bulkhead
70. investigate a transformer change in HC #2
71. install hard piping from HC #2 to quarterdeck with relief valve
72. install exterior lighting on the HC's by doorways and in the walkway
73. install safety shield between the drive line on the compressors and the fuel tank
74. have all field repaired piping checked for defects in welding by certified inspection agency
75. procure stock of spare piping including long sweep 90's and couplings for future programs
76. Install inspection hatches onto the air plenums on HC's

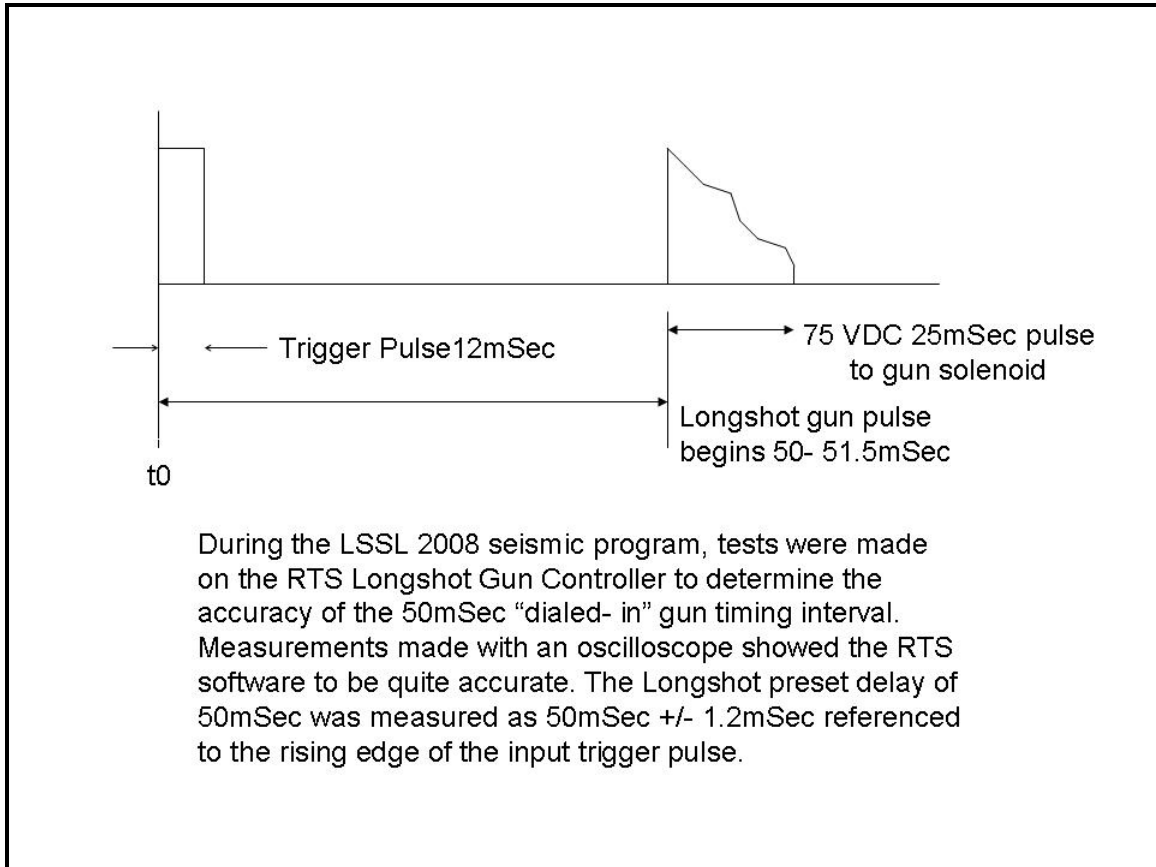
77. Install a "drip leg" on the quarterdeck air piping
78. Install interior and exterior thermometers
79. Install plenum manometers
80. Install heat trace tape and insulation on all piping from compressor to quarterdeck
81. Install digital pressure gages across air distribution system, at the outlet of each compressor and at the quarterdeck to monitor freeze-ups in these lines
82. Add capability to remotely transfer load from HC #1 to HC #2 or vice versa
83. Change analog gages on HC monitor PC's to Bar Graph
84. Install a band brake to the streamer winches
85. Promote safety regulations re establishing a "no go" area between the sled and benches during sled deployment
86. Use a "cable stop" to secure the cable bundle while tugger winch cable is being repositioned during deployments and recovery
87. Investigate the use of a "cavity notch filter" between Winradio receiver and antenna
88. Relocate the Winradio receiver to the crow's nest to reduce cable losses
89. install a fixed fall arrestor system in the crow's nest
90. install an Omni antenna for the sonobuoy receiver to improve reception during course changes
91. exhaust fan above the work bench
92. investigate relocating the injection points for antifreeze into each gun line
93. install cable tray at the deck head to handle the antifreeze hoses and electrical lines
94. inspection mirror for compressor servicing
95. retrieval tools for compressor maintenance
96. dye penetrate crack detection spray
97. improve the inboard centre fairlead system to better handle bundle clamps on deployment



### 5.3.7 Technical Appendices

#### Appendix A: Real Times System Longshot Calibration

The purpose of this exercise was to determine the accuracy of the “dialed in delay” vs. the actual measured delay in the RTS Longshot computer:



#### Appendix B: Hurricane Air Compressor Operator’s Log Sheets

See attached files:

- (1) HC #1 file: Louis 2008 Stb’d Compressor Log.xls
- (2) HC# 2 file: Louis 2008 Port Compressor Log.xls

Operator’s log Sheets for the  
Louis 2007 Electronic Log.xls

#### Appendix C: Safe Operating Procedure for the Startup of the Hurricane Air Compressor

1. Read and understand all safety rules and procedures about the operation of the Hurricane Air Compressor as outlined in the Hurricane Manual for this machine
2. Check all fluid levels

3. Drain fluid remaining in accumulator tanks and leave valves open
4. Do not attempt to start the compressor with air in the compressor system
5. Ensure compressor discharge valve is in the OPEN state
6. Ensure Emergency Stop switches are disengaged (extended condition)
7. Turn the “Unload/ Auto load” switch to the “Unload” state
8. Turn the “Off/ Run/ By-Pass” switch to the Bypass position and hold
9. Check for tripped tattle tale breakers and reset if necessary
10. Push and hold the “Start” button until the engine starts. Do not hold this switch and allow the diesel engine to turn over for more than 15 seconds. After 15 seconds release the “Start” button for 60 seconds to allow starter to cool and then repeat the start procedure
11. Observe engine RPM and maintain the RPM at 1200
12. While holding the “Off/ Run/ By-Pass” switch observe the 1<sup>st</sup> stage Pumper oil pressure. Keep the “Off/ Run/ By-Pass” switch engaged in the “By-Pass” position until Pumper oil pressure exceeds 20 PSI. If the oil pressure does not climb quickly shut the engine down immediately and investigate the reason for lack oil Pumper oil pressure before restarting the system again
13. Do not load the compressor until diesel engine and Pumper 1<sup>st</sup> stage operating temperatures reach 130 degrees Fahrenheit
14. Close Moisture Dump Valves on Accumulators
15. Turn “Unload/ Auto Load” switch to Auto Load and adjust engine RPM as load demands

## Appendix D: Sonobuoy deployment times and line numbers

This table contains information for the start and end times and line numbers for the 39 sonobuoys which were deployed on the 2008 LSSL Seismic program.

<b>LSSL 2008 Sonobuoy</b>			
Sonobuoy No.	Start	End	Line No.
1	241/0124	241/0914	LSL0801a
2	241/0916	241/1623	LSL0801a, LSL0802a
3	241/1636	241/2232	LSL0802a
4	242/0537	242/1312	LSL0803a
5	242/1314	242/2116	LSL0804a
6	242/2122	243/0641	LSL0804a, LSL0805a
7	243/0810	243/1610	LSL0805a
8	243/1615	244/0008	LSL0805a
9	244/0029	244/1145	LSL0805a
10	245/0009	245/1130	LSL0805b
11	245/1149	245/2336	LSL0805b, LSL0806a
12	245/2354	246/1142	LSL0806a
13	246/1148	247/0002	LSL0806a
14	247/0008	247/1136	LSL0806a
15	247/1145	247/1507	LSL0806a
16	248/0220	248/1353	LSL0806b
17	248/1404	248/2217	LSL0806b, LSL0807a
18	249/0218	249/1100	LSL0807a
19	249/1915	250/0351	LSL0807b
20	250/0404	250/1300	LSL0807b
21	250/1632	250/2120	LSL0807b
22	254/0636	254/1818	LSL0808a
23	254/1826	255/0430	LSL0808a
24	255/0628	255/1833	LSL0808a
25	255/1916	256/0439	LSL0808a
26	Receiver malfunction		
27	Receiver malfunction		
28	258/0343	258/1005	LSL0809a
29	259/0016	259/0520	LSL0809b
30	259/1213	259/1543	LSL0809b
31	260/0523	260/1039	LSL0810a
32	260/2340	261/1100	LSL0810a
33	262/0013	262/1043	LSL0810a, LSL0810b

34	265/0420	265/1348	LSL0811a
35	265/1401	265/1630	LSL0811a
36	265/2342	266/1135	LSL0811b
37	267/0326	267/1330	LSL0811c
38	268/0050	268/1235	LSL0812a, LSL0812b
39	269/0218	269/1305	LSL0812b

## Appendix E: Geometrics GeoEel configuration

Table E.1 2008 Starboard Side Streamer Configuration.

Julien Day	STBD Original		Day 248	Day 260	265	266
Section	Length(M)	Serial Number	Serial Number	Serial Number	Serial Number	Serial Number
Deck/Lab Cable Repeater		DC1063 RP01089	DC1063 RP01089	DC1063 RP01089	DC1063 RP01087	DC1063 RP01087
Bundle Cable Repeater		DC01067 RP01087	TC01073 RP01088	DC01067 RP01088	DC01067 RP01085	DC01067 RP01085
Float Tow Cable Repeater	90	TC01064 RP01084	TC01064 RP01084	TC01064 RP01084	TC01064 RP01084	TC01066 RP01084
Stretch	25	S01073	S01076	S01076	S01073	S01073
Anti-Vibe	10	V1064	V1064	V1064	V1064	V1064
Anti-Vibe	10	V1062	V1063	V1063	V1063	V1060
A/D Module Active	50	DG01172 ARD1047	DG01172 ARD1047	DG01172 ARD1047	DG01172 ARD1047	DG01172 ARD1047
A/D Module Active	50	DG01173 ARD1050	DG01175 ARD1056	DG01175 ARD1056	DG01175 ARD1050	DG01175 ARD1050
Anti-Vibe	10	V1060	V1060	V1060	V1060	V1074
Anti-Vibe	10	V1061	V1061	V1061	V1061	V1072
Stretch	25	S01075	S01075	S01075	S01075	S01074
Tail Swivel		TS01004	TS01004	TS01004	TS01004	TS01002

Table E.2 2008 Port Side Streamer Configuration.

Julien Day	Port Original		262	265
Section	Length(M)	Serial Number	Serial Number	Serial Number
Deck/Lab Cable Repeater		DC1063 RP01089	DC1063 RP01087	DC1063 RP01087
Bundle Cable Repeater		DC01068 RP01088	TC01064 RP01089	TC01064 RP01089
Float Tow Cable	90	TC01065	TC01065	TC01065 Used With
Repeater		RP01085	RP01085	STBD
Stretch	25	S01080	S01080	S01080
Anti-Vibe	10	V1076	V1076	V1076
Anti-Vibe	10	V1075	V1075	V1075
A/D Module		DG01176	DG01176	DG01176
Active	50	ARD1089	ARD1089	ARD1089
A/D Module		DG01174	DG01174	DG01174
Active	50	ARD1052	ARD1052	ARD1052
Anti-Vibe	10	V1074	V1074	V1074
Anti-Vibe	10	V1072	V1072	V1072
Stretch	25	S01074	S01074	S01074
Tail Swivel		TS01002	TS01002	TS01002

Table E.3 October 2008 Streamer Component Inventory and Status.

Section Type	Ser. No.	Length (M)	Condition	Comments
Deck/Lab Lead-in Cable	DC01063	23	Good	Coiled on top of Seismic Lab
Bundle Cable (Original)	DC1067	35	Good	Box #8 Remain on Board SN Shows DC1068
Bundle Cable (Repaired)	DC1068	35	Damaged	Box #4 For Repairs (Repaired in 2007)
Bundle Cable (New)	TC01072	35	Good - Unused	Box #6 Remain on Board
Bundle Cable (New)	TC01073	35	Damaged	Box #1 For Repairs
Float Tow Cable (Modified)	TC01064	90	Damaged	Box #9 For Repairs
Float Tow Cable (Modified)	TC01065	90	Damaged	Box #1 For Repairs
Float Tow Cable (Modified)	TC01066	90	Good	Box #3 Remain on Board
Active (Original)	ARD1047	50	Depth Not Working	Box #7 For Repairs
Active (Repaired)	ARD1052	50	Damaged	Box #7 For Repairs (Repaired in 2007)
Active (Original)	ARD1056	50	Damaged	Box #4 For Repairs
Active (Original)	ARD1050	50	Depth Not Working	Box #4 For Repairs
Active (New)	ARD1089	50	Good	Box #8 Remain on Board
Stretch (Original)	S01073	25	Good	Box #3 Remain on Board
Stretch (Original)	S01074	25	Good	Box #2 Remain on Board
Stretch (Original)	S01075	25	Good	Box #2 Remain on Board
Stretch (Original)	S01076	25	Good	Box #6 Remain on Board
Stretch (New)	S01080	25	Good	Box #2 Remain on Board
Anti-Vibe (New)	V1072	10	Good	Box #2 Remain on Board
	V1073	10	Good	Box #6 Remain on Board
Anti-Vibe (New)	V1074	10	Good	Box #2 Remain on Board
Anti-Vibe (New)	V1075	10	Good	Box #8 Remain on Board
Anti-Vibe (New)	V1076	10	Good	Box #8 Remain on Board
Anti-Vibe (Original)	V1060	10	Good	Box #2 Remain on Board
Anti-Vibe (Original)	V1061	10	Good	Box #6 Remain on Board
Anti-Vibe (Original)	V1062	10	Damaged	Box #9 For Repairs
Anti-Vibe (Original)	V1063	10	Damaged	Box #9 For Repairs
Anti-Vibe (Original)	V1064	10	Good	Box #4 Remain on Board

**Table E.4 A-to-D and Repeater Module Inventory and Status, October 2008**

<b>Module Type</b>	<b>Serial Number</b>		
Repeater (Original)	RP01084	Good	Pelican Case On Board
Repeater (Original)	RP01085	Good	Pelican Case On Board
Repeater (Original)	RP01087	Not Working	Pelican Case For Repairs
Repeater (Original)	RP01088	Loose End Connector	Pelican Case For Repairs
Repeater (Original)	RP01089	Good	Pelican Case On Board
AIDConverter (Original)	DG01172	Good	Pelican Case On Board
AIDConverter (Original)	DG01173	Not Working	Pelican Case For Repairs
AIDConverter (Original)	DG01174	Not Working	Pelican Case For Repairs
AIDConverter (Original)	DG01175	Bent Pin	Pelican Case For Repairs
AIDConverter (Original)	DG01176	Good	Pelican Case On Board
AIDConverter (Original)	DG01177	Good (New)	Pelican Case On Board
Tail Swivel (Original)	TS01002	Good	Box # End of S01074
Tail Swivel (Original)	TS01003	Good (New)	Pelican Case On Board
Tail Swivel (Original)	TS01004	Good	Box #2 End of S01075

NOTE:  
 The noted modules to be returned to Geometrics for service are located inside a Pelican case in Box #9



Table E.5 Streamer Storage and Shipment Inventory, October 2008.

End 2008 - Box Contents		
For Shipment	Remain On Board	
Box # 1	Box # 2	Box # 6
TC01065	S01074	TC01072
TC01073	S01075	S01076
Box # 4	S01080	V1061
DC01068	V1060	V1073
ARD1050	V1072	Box # 8
ARD1056	V1074	DC01067/68
Box # 7	Box # 3	ARD1089
ARD1047	TC01066	V1075
ARD1052	S01073	V1076
Box # 9	V1064	
TCO1064		Box # 5 Empty
V1062		
V1063		

## **Appendix F: Acknowledgements:**

The author wishes to thank the following for their contribution to the success of the program:

Captain, Officers and Crew of the Canadian Coast Guard Ship "Louis S. St. Laurent"  
Without their tireless support, the 2008 program would not have been a success;

The Technical Support Crew:

Mr. Jim Etter: Hydraulics, electronics and watch keeping

Mr. Paul Girouard: Navigation, network, and data curation

Mr. Fred Learning; Air gun tow sled, compressor mechanical, watch keeping

Mr. Rodger Oulton: Compressor and diesel mechanical and watch keeping

Mr. Dwight Reimer: GeoEel system, air gun control and watch keeping

Mr. Ryan Pike: Inventory control, air gun mechanical, watch keeping

Mr. Nelson Ruben: Air gun, tow sled and compressor, mechanical

Mr. Peter Vass: Machinery fabrication and equipment maintenance

These individuals worked long and hard to accomplish a task that at times, seemed to us impossible:

NRCan Staff of the Shared Services Office at GSC (A) in Dartmouth NS: Barb Vetese, Cheryl Boyd and Terry Hayes.

Without the cooperation and hard work of these individuals, our scientific program in 2008 would simply not have "gotten away from the wharf"!

## 6 Acquisition and Processing of the Seismic Reflection Data

John Shimeld

### 6.1 Introduction

A total of 2817.1 line km of 16-channel, normal incidence, 2D seismic reflection data were acquired over abyssal plain and continental slope regions of Canada Basin and Chukchi Plateau in the Arctic Ocean (Figure 5.1). Conditions ranged from open water with light swells through to completely ice-covered seas with, in several cases, up to 9/10 multiyear ice that was 2-3 m thick and under light to moderate compression with 2 m high ridges. The data quality is good to excellent except for isolated regions where ice conditions were the heaviest and the icebreaking operations caused significant noise on the records. From the standpoint of data quality, it may have been possible to successfully acquire data under slightly heavier ice conditions than were encountered during this cruise since seismic basement and the overlying sedimentary sequences were adequately imaged on all lines. However the risk of equipment damage or loss increases greatly as the ice thickens and the 2-3 m multiyear ice that was encountered this year likely represents the feasible limit of the two-ship seismic operation (*c.f.* Section 4).

The data were acquired along 12 lines, each of which is comprised of one or more segments. These are named with the prefix LSL08 followed by the line number and a letter indicating the line segment. For example, LSL0807b indicates segment b of line 7. Seismic acquisition continued along each line segment until adverse ice conditions or equipment failure prevented further progress, or until the end of the originally planned line was reached. In total, there are 21 line segments. A summary of the shotpoint ranges and line km for each is given in Table 5.1.

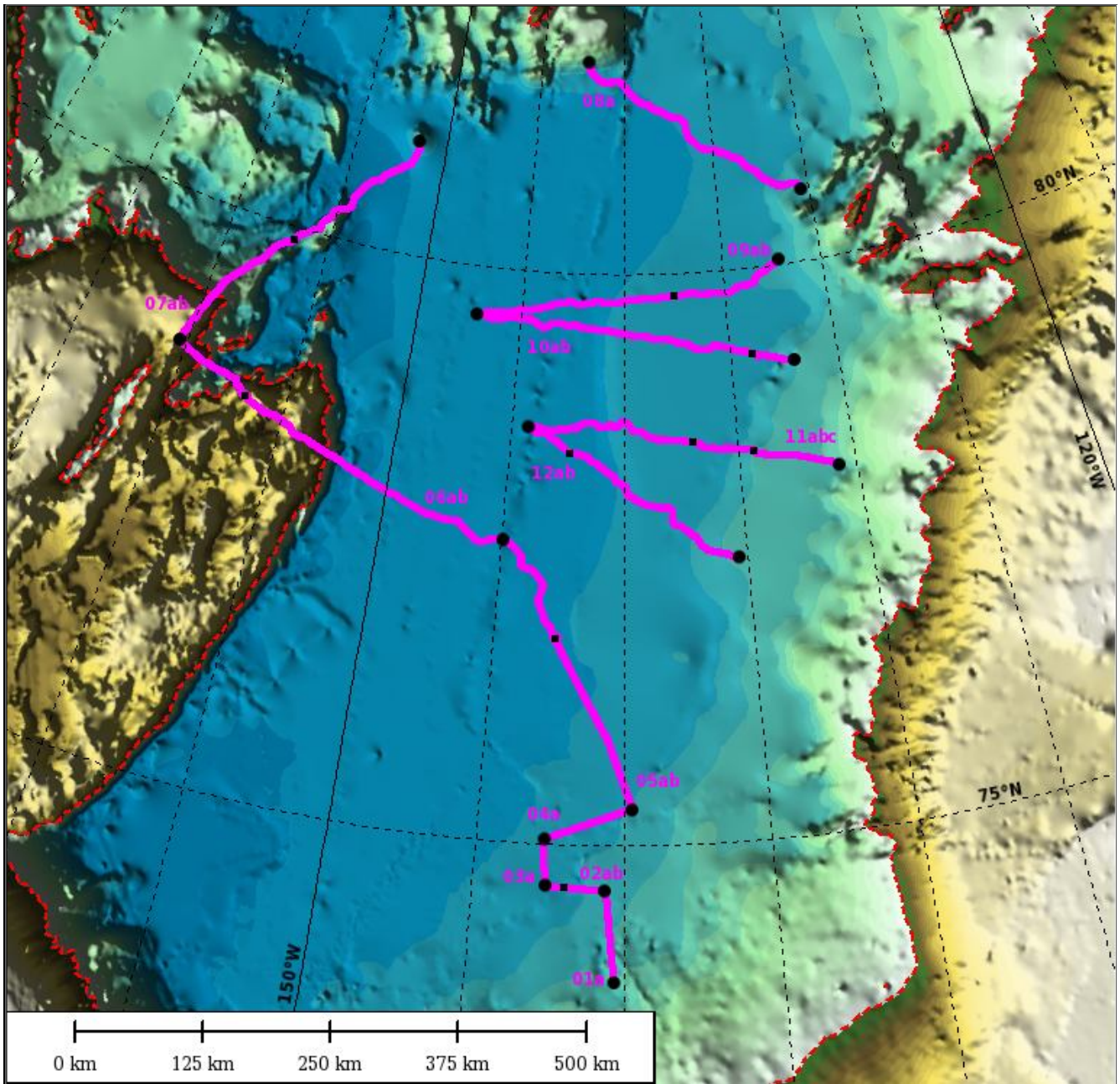


Figure 6.1 Regional trackplot map of the 16-channel, normal incidence, 2D seismic data acquired during the cruise. Twelve lines (LSL0801 through LSL0812) were acquired along a total of 21 segments (labelled a, b, and c). Black circles indicate the start/end of each line and black squares indicate the start/end of each line segment. Line labels are placed adjacent to segment a of each line. The backdrop is a shaded relief image of the International Bathymetric Chart of the Arctic Ocean (second edition) with distinct colour bands for each 100 m increment of water depth. The darkest blue represents water depths of 3800 m or greater. The dashed red line delineates the 2500 m isobath.

**Table 6.1 Summary of line segments acquired during the survey.**

<b>Line Segment</b>	<b>First Good Shotpoint</b>	<b>Last Good Shotpoint</b>	<b>Line Kilometres</b>
1. LSL0801a	14	2569	89.7
2. LSL0802a	2750	3892	42.6
3. LSL0802b	3920	4350	14.4
4. LSL0803a	4351	5699	45.4
5. LSL0804a	5700	8289	91.4
6. LSL0805a	8342	13505	191.7
7. LSL0805b	13514	16950	123.1
8. LSL0806a	16951	27057	302.5
9. LSL0806b	27114	30275	92.4
10. LSL0807a	30301	35241	149.0
11. LSL0807b	35400	40301	176.4
12. LSL0808a	40302	49241	265.2
13. LSL0809a	49242	53088	122.7
14. LSL0809b	53089	58536	195.4
15. LSL0810a	58537	66612	281.7
16. LSL0810b	66617	68476	45.2
17. LSL0811a	68479	71088	84.1
18. LSL0811b	71089	73069	60.0
19. LSL0811c	73070	77948	180.3
20. LSL0812a	77949	79434	51.6
21. LSL0812b	79435	85664	212.5
			<b>total: 2817.1 km</b>

## 6.2 Source Parameters

### 6.2.1 Source Array

A cluster of 3 Sercel G-guns was used as the seismic source during the survey. The port and starboard airguns each had a volume of 550 in<sup>3</sup>, and these were suspended beneath the tow sled 1 m apart from each other and 1 m aft of the midship airgun. Initially, a 550 in<sup>3</sup> airgun was also used in the midship position but this configuration caused excessive recoil when firing the cluster, leading to undue wear on the air lines and connectors. Therefore, to alleviate the recoil, a smaller (150 in<sup>3</sup>) airgun was used in the midship position. The airgun cluster configurations used during the survey are listed below in Table 5.2.

**Table 6.2 Configurations of the airgun cluster used as the seismic source during the survey.**

Line Segment	Port Airgun (in <sup>3</sup> )	Midship Airgun (in <sup>3</sup> )	Starboard Airgun (in <sup>3</sup> )	Comments
LSL0801a	520	520/0	520	midship airgun stopped @SP 1110
LSL0802a	520	0	520	
LSL0802b	520	520/0	520	midship airgun stopped @SP 4257
LSL0803a	520	0	520	
LSL0804a	520	0	520	
LSL0805a	520	0	520	
LSL0805b	520	150	520	
LSL0806a	520	150	520	
LSL0806b	520	150	520	
LSL0807a	520	150	520	
LSL0807b	520	150	520	
LSL0808a	520	150/0	520	midship airgun stopped @SP 48450
LSL0809a	520	150	520	
LSL0809b	520	150	520	
LSL0810a	520	150	520	
LSL0810b	520	150	520	
LSL0811a	520	150	520	
LSL0811b	520	150/0	520	midship airgun stopped at SP 71497
LSL0811c	520	150	520	
LSL0812a	520	150	520	

## 6.2.2 Shot Interval

The source was fired at regular time intervals as a function of water depth. These are listed below in Table 5.3.

**Table 6.3 Shot intervals used during the data acquisition.**

<b>Two-Way Time to Seafloor Reflection (s)</b>	<b>Shot interval (s)</b>	<b>Approximate Shotpoint Interval (m)</b>
3–4	14	30
4–5	17	35
> 5	19.5	40

## 6.2.3 Calibrated Measurements of the Seismic Source

Recordings of the source wavelet generated by the G-guns were made using a Neptune Sonar Type T49 calibrated hydrophone (*c.f.* Section 4). This was initially attempted on August 27<sup>th</sup> (day 240) before the start of the seismic survey, but the recording equipment malfunctioned and the tests had to be abandoned. Subsequently source wavelet recordings were made during September 16<sup>th</sup> (day 260) and September 26<sup>th</sup> (day 270).

With the ship stationary, the calibrated hydrophone was lowered into the water from the quarterdeck to a depth of 400 feet below the sea surface. Various combinations of airguns were then fired using an air pressure of 1925 pounds per square inch, and a number of shots were recorded in SEG-Y formatted files using the AGCDIGS digitizer with a sample interval of 43  $\mu$ s and a recording window of 545.713 ms (12692 samples). Recordings were also made with the calibrated hydrophone suspended at 200 feet below sea surface on September 16<sup>th</sup>, but there was insufficient time to do this on September 26<sup>th</sup>. A summary of the recordings of various gun combinations is given in table 4.

The source measurements were by necessity done during brief opportunities when there was a break in seismic acquisition and when the ice conditions were appropriate. Unfortunately, as noted in table 4, a significant number of airgun timing errors occurred during the tests because there was insufficient time available to completely clear the airlines of ice build-up and to let the airguns stabilize. The constraint on time available for the source measurements was further tightened by the need to finish the tests quickly before ice could form in the airgun ports and jeopardize planned seismic acquisition.

A more serious issue, also noted in table 4, is that gain changes are apparent on shot records from both September 16<sup>th</sup> and 27<sup>th</sup>. Since these records were made during the middle of the tests, there is reason to suspect systematic errors in the

amplitudes of all the source measurements. Careful analysis is necessary to quantify the gain changes, correct the trace amplitudes, and determine an absolute sound production level if possible. No attempt was made to do this in the field.

**Table 6.4 Summary of source wavelet recordings made using calibrated hydrophone. Each file name gives the receiver depth, airgun position within the cluster, airgun volume (cubic inches), and the recording date (year, calendar day, hour, minute, second UTC).**

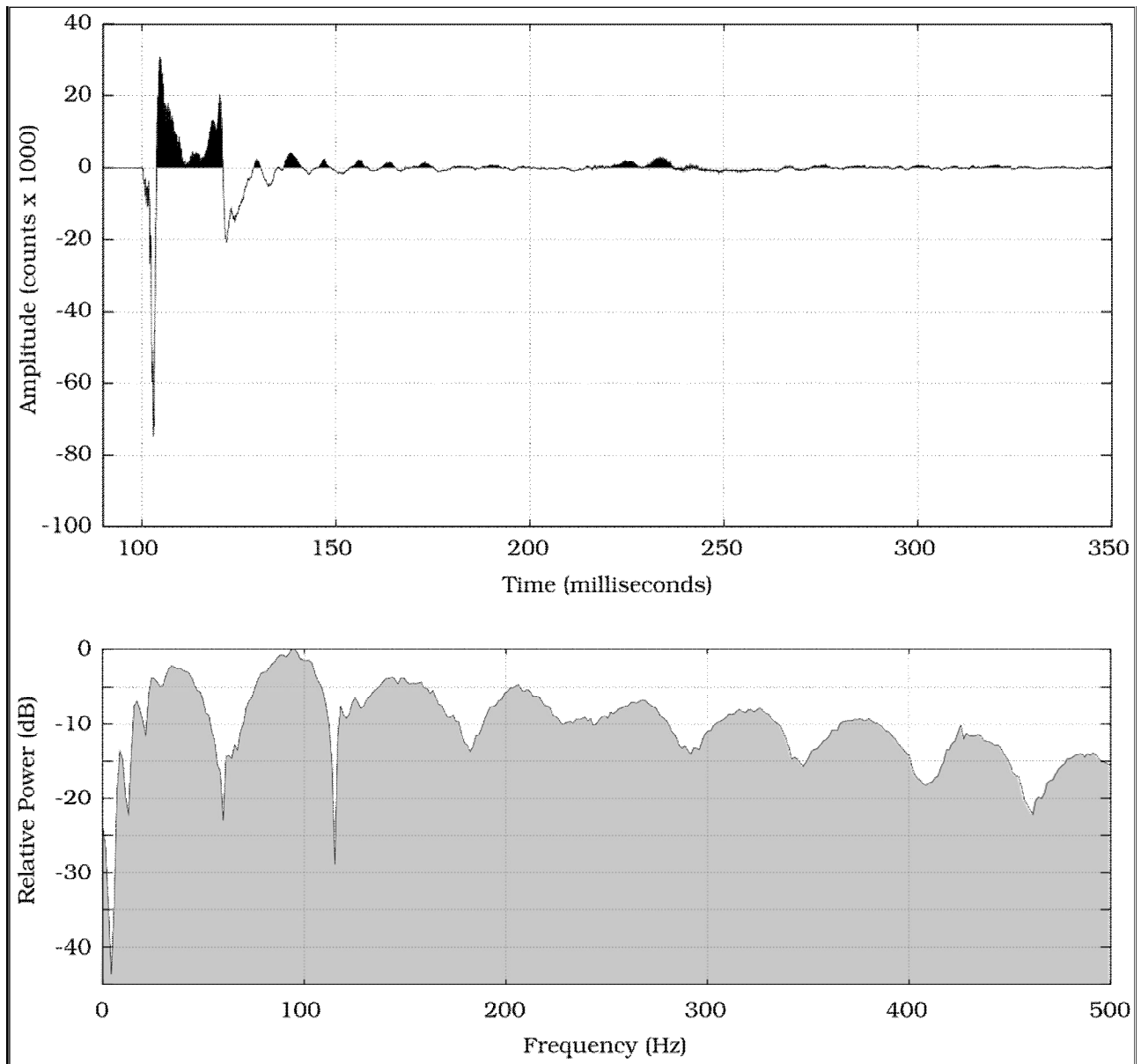
File Name	Shots	Comments
200ft_stbd520_mid150_pt520_2008_260_04_59_22.SGY	19	gun timing errors: shot 149
200ft_stbd520_pt520_2008_260_05_05_07.SGY	15	gun timing errors: shots 178–179
400ft_mid150_2008_260_04_20_54.SGY	18	
400ft_mid150_pt520_2008_260_04_35_02.SGY	15	
400ft_pt520_2008_260_04_24_31.SGY	16	misfire: shot 26; drift in time break: shots 27–35
400ft_stbd520_2008_260_04_27_51.SGY	17	gain change between shot 42 and the remaining shots 43–58
400ft_stbd520_mid150_2008_260_04_31_36.SGY	17	
400ft_stbd520_mid150_pt520_2008_260_04_44_20.SGY	50	gun timing errors: shots 109–149
400ft_stbd520_mid520_pt520_2008_270_15_42_18.SGY	43	gain changes across all shots; gun timing errors: all shots
400ft_stbd520_pt520_2008_260_04_39_02.SGY	18	gun timing errors: shot 91

To derive an estimate of the source wavelet for predictive deconvolution, ten traces were aligned and stacked from each of the two following files:

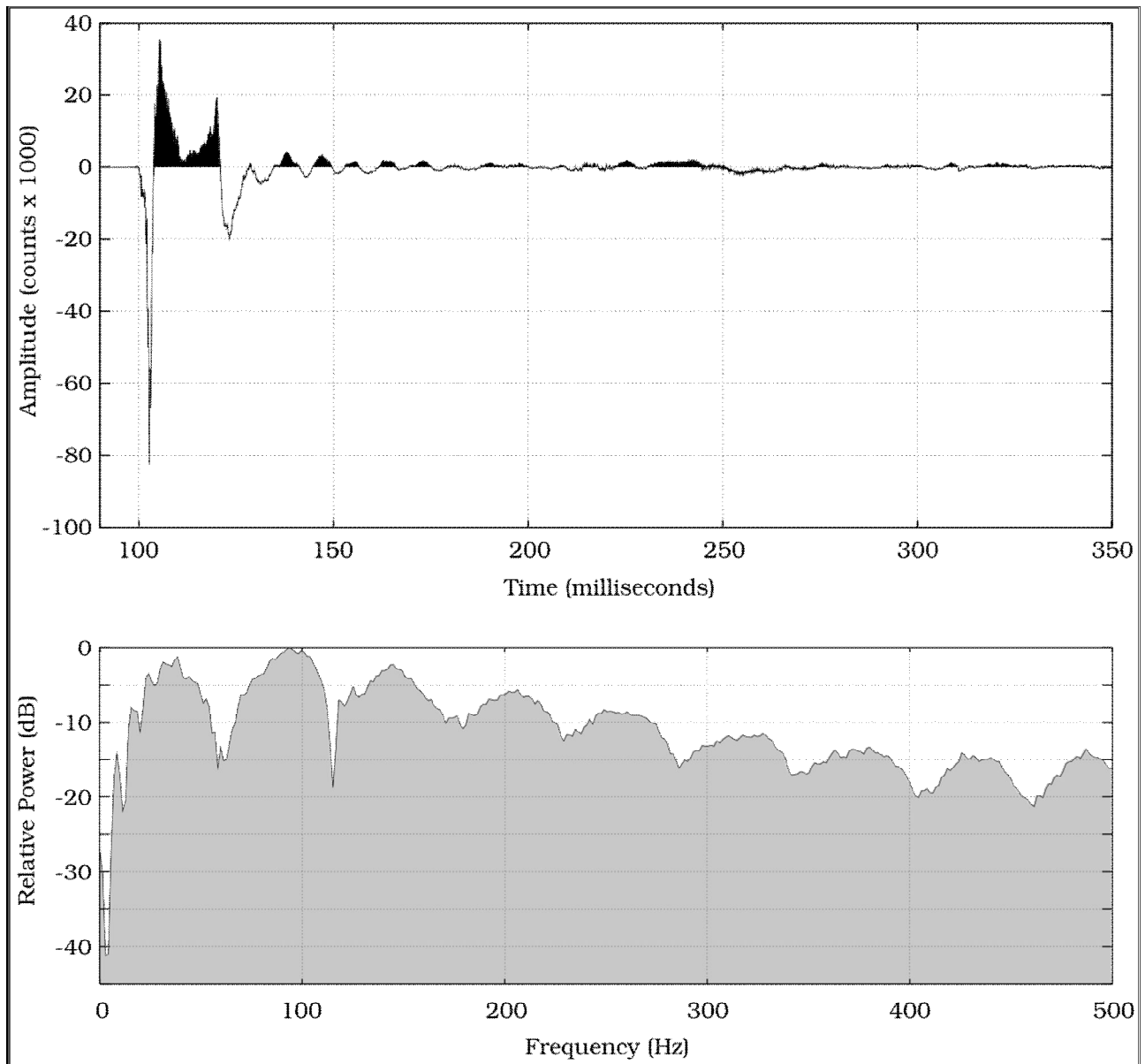
1. 400ft\_stbd520\_pt520\_2008\_260\_04\_39\_02.SGY; and
2. 400ft\_stbd520\_mid150\_pt520\_2008\_260\_04\_44\_20.SGY.

The time series and relative power spectra for the above source wavelets exhibit a high degree of similarity (figures 2 and 3). In both cases notches occur in the power spectra at 5.0, 11.9, 20.5, and 28.5 Hz due to destructive interference between the primary and bubble pulses. Also, power in the 50 to 72 Hz band is significantly reduced by destructive interference between the primary and source ghost pulses. This corresponds to a source depth of 11.8 m below the sea surface using a notch frequency of 61 Hz and a measured near-surface water velocity of 1440 m/s (personal communication, Jon Biggar, from sound velocity profiles made during the cruise). In comparison with the two-gun cluster (Figure 5.2), the addition of a 150 in<sup>3</sup> airgun in the mid-ship position (Figure 5.3) adds power in the 25–50 Hz and 75–90 Hz bands and increases the peak-to-bubble ratio slightly from 2.6 to 3.0.





**Figure 6.2** Time series and relative power spectrum of the source wavelet derived by aligning and stacking ten traces from 400ft\_stbd520\_pt520\_2008\_260\_04\_39\_02.SGY. The peak to bubble ratio is 2.6. Destructive primary–bubble pulse interference causes notches in the power spectra at 5.0, 11.9, 20.5, and 28.4 Hz. The notch between 50 and 72 Hz is caused by destructive interference between the primary and source ghost pulses.



**Figure 6.3** Time series and relative power spectrum of the source wavelet derived by aligning and stacking ten traces from 400ft\_stbd520\_mid150\_pt520\_2008\_260\_04\_44\_20.SGY. The peak to bubble ratio is 3.0. Destructive primary–bubble pulse interference causes notches in the power spectra at 5.0, 11.9, 20.5, and 28.4 Hz. The notch between 50 and 72 Hz is caused by destructive interference between the primary and source ghost pulses.

### **6.3 Receiver Parameters**

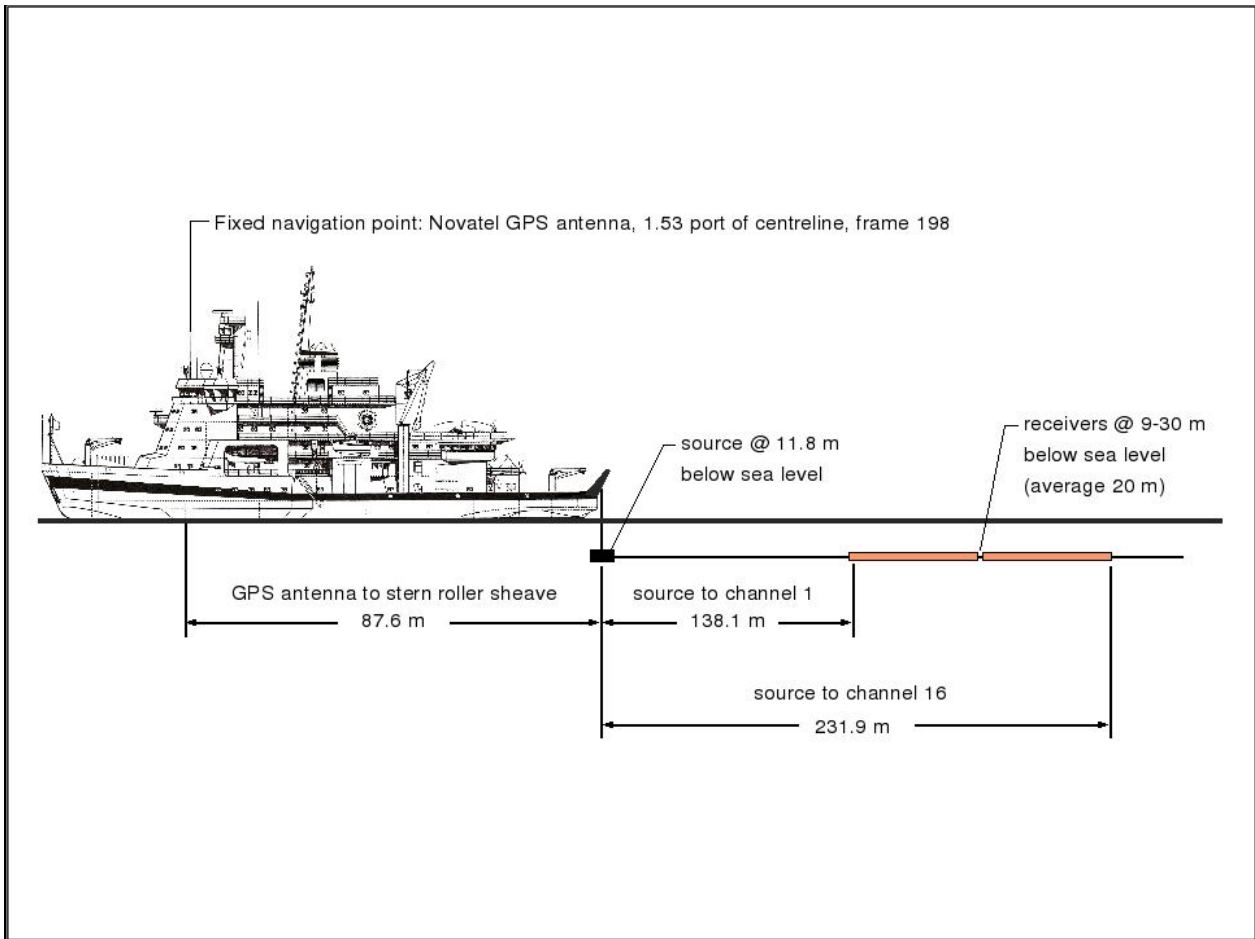
The receiver array consisted of two active sections, each 50 m long with 64 equally spaced hydrophones. These were configured into 8 channels per active section with 8 hydrophones per group. Accordingly, there were a total of 16 active channels and the group interval was 6.25 m.

### **6.4 Source/Receiver Offsets**

The Novatel Global Positioning Satellite (GPS) antenna located above the wheelhouse top at frame 198 of the ship was used as the fixed navigation point for the survey. The source and receiver offsets relative to this fixed navigation point are shown on Figure 5.4.

### **6.5 Recording Parameters**

Seismic reflection data were recorded using the Geometrics GeoEel system described in Section 4. With this system, analog hydrophone signals are converted to 24-bit digital traces by analog-to-digital converters in the streamer and are automatically summed for each receiver group. The trace data from each receiver group are broadcast, via ethernet connection in the streamer, to the multithreaded CNT-2 software running under the Windows NT operating system on a personal computer in the seismic lab. The CNT-2 software provides a user interface for configuring the GeoEel system, for monitoring the data quality during acquisition, for testing the receiver array, and for recording the data to magnetic disk drive and/or magnetic tape. Additional data such as geographic position or source signature information can also be logged by the CNT-2 software through a serial communications port. The recording parameters that were used during the survey are listed in Table 5.5.



**Figure 6.4** Offsets between the fixed navigation point, the source, and the near and far channels of the receiver array.

**Table 6.5 Recording parameters used with the CNT-2 software during the survey.**

<b>Parameter</b>	<b>Value</b>
Group Interval	6.25 m
Sample interval	2.000 ms
Recording window	13.5 seconds
Recording delay	0.0 s for segments LSL0801a through LSL0807a 0.5 s for segments LSL0807b through LSL0812b
Active channels	1 through 16 (near trace: 1; far trace: 16)
Low cut analog filter	AC coupling in the GeoEel digitizer acts as a 3 Hz low cut filter. This setting was used for all line segments except LSL0805a through LSL0807a.
Shot/file number comparison	not enabled
Preamp gains	Preamp gains were set to +30 dB for all line segments except LSL0805a through LSL0807a, for which the preamp gains were set to +6 dB.
Transconductance	20 Volt/bar
Noise analysis peak threshold	18 microbar
Noise analysis average threshold	9 microbar
Noise analysis low cut frequency	6 Hz

## 6.6 Noise Records

On August 26th, before the start of the seismic survey, a series of recordings were made of the ambient noise in the water without the airguns firing. In addition to testing the receiver and acquisition systems, these recordings were conducted to investigate the signature of noise generated by equipment onboard the Louis S. St. Laurent. During the noise tests, the ship was in open water with 10–15 knot winds and 2.0–2.5 m swells from astern. The sequence of tests that were performed is summarized below in Table 5.6.

**Table 6.6 Summary of tests conducted to measure ambient noise in the water.**

<b>Record #</b>	<b>Streamer</b>	<b>Tow Point</b>	<b>Knots</b>	<b>Centre Prop.</b>	<b>Bubbler</b>
1–195	starboard	ship rail	2.7 to 1.4 (decreasing)	yes	no
196–345	starboard	ship rail	3.2–3.8	yes	no
346–574	starboard	ship rail	3.9–4.3	yes	no
575–700	starboard	ship rail	3.6–4.0	no	yes
701–851	starboard	ship rail	4.0 to 0.2 (decreasing)	no	yes
852–905	starboard	ship rail	0.2–1.4 (streamer drifting to starboard of stern. Use port shaft to move off)	no	yes
906-1079	starboard	ship rail	3.7–4.3	no	yes
1080–1180	port	ship rail	1.4–2.4	no	no
1181–1317	port	ship rail	3.0–3.2	no	no
1318–1425	port	ship rail	3.6–4.3	no	no
1450–1570	starboard	airgun sled	2.0–3.7	no	no
1571–1850	starboard	airgun sled	3.9–4.3	no	no

### *Noise Test Results*

A plot of the unfiltered traces for record 101 is shown on Figure 5.5. At this time the propeller revolutions per minute were minimal and speed through the water was 1.3 knots, so the record is a good representation of ambient sound in the water without noise from the propellers or from towing the streamer. Energy below 3.0 Hz dominates the record, which is due to the 2.0–2.5 m swells that were present during the test.

When the swell noise is removed using a 3.0/8.0 Hz low cut filter, a distinctive pattern of coherent noise is revealed with peaks visible in the amplitude spectrum every 5 Hz interval and also at some 2.5 Hz intervals (Figure 5.6). Particularly strong spikes occur at 10, 15, 20, 30, 35, 37.5, 40, 97.5 and 120 Hz. This coherent noise is from power generators, compressors, and engines onboard the Louis S. St. Laurent which transmit electro-mechanical signals through the hull of the ship and into the water, and the amplitude of this noise correlates closely with the amount of power applied to the ship propellers.

On individual records, such as plotted on Figure 5.6, coherent noise is manifested as a series of events with both positive and negative dips (positive dips correspond to events travelling from the near trace to the far trace). As seen in the F-K spectrum, these dips are predominantly  $\pm 4.3$  ms/trace, or about 1450 m/s, which agrees well with the observed near-surface water velocity (personal communication, Jon Biggar). Dips of -2.2 and -1.2 ms/trace are also present, which correspond to apparent velocities of 2840 and 5200 m/s, respectively. The nature of these events is enigmatic; it is plausible that some energy might travel within the streamer itself, perhaps at velocities around 2800 m/s, but not likely at 5200 m/s. Since the observed dips are nearly integral divisors of the predominant dip (i.e. 1/2 and 1/4 of 4.3 ms/trace), it seems likely that the shallow negative dips are caused by some form of aliasing.

At times when the power to the propeller shafts is increased in order to change the ship's speed or heading, or to provide more thrust for ice breaking, the noise records exhibit a distinctive pattern of high amplitude, coherent events with both positive and negative dips of about 35 ms/trace (200 m/s). The records on Figure 5.7 provide a clear example when the ship speed was being increased from 1.4 to 3.8 knots. The resultant coherent noise is strongly focused in the 4–8 Hz band. Initially, noise of this sort was ascribed to strumming of the tow cable and streamer in the turbulent prop wash. Near the middle of the cruise, however, the repeater unit immediately aft of the airgun sled was secured about 1 m further downstream of the sled than had previously been the practice. Immediately after this change, a significant reduction was observed in the coherent noise that had been thought to be related to strumming. Therefore the nature of this noise remains uncertain; it may be related to strumming, or perhaps it is caused by electromagnetic interference introduced into the repeater unit through proximity to the airgun sled and metal tow cable.

Near trace plots are shown on Figure 5.9 for records 76–175 and 721–820. During both these record intervals, minimal power was applied to the ship propellers and speed through the water was falling. In the latter case, though, the ship air bubbler system was in operation and the streamer drifted progressively closer to the stern. Qualitatively, the bubbler system adds very little noise to the records when the streamer is in its normal position more than 100 m astern (i.e. records 721–750 with respect to records 76–175). Noise from the bubbler system becomes increasingly evident as the distance between the ship and the streamer decreases. Comparison of

the two amplitude spectra plotted on Figure 5.9 demonstrates that the bubbler system adds coherent noise at the distinct 5.0 and 2.5 Hz intervals described earlier. This is likely because of the increased power generation necessary to run the air compressor. Random noise is also added by the bubbler system, but the level is not significant when the streamer is in the normal towing position.

Coherent noise bursts of more than 2 seconds in duration are evident on roughly every fifth trace of the near trace plot shown on Figure 5.9. Noise of this sort contaminated the records throughout a number of time intervals during the survey. It is similar to noise bursts that appear on the sonobuoy records. No specific cause could be identified, but it is suspected that the noise bursts are created by electromagnetic radiation emanating from a radio beacon onboard the Louis S. St. Laurent. Again, this suggests that electromagnetic interference somehow affects the acquisition system perhaps either through the repeater unit or the deck cable.

Variable density plots of the near traces from records 401–500 and 1601–1700 are shown on Figure 5.10. The starboard streamer system was deployed during both these record intervals, and the speed through the water was comparable at about 3.8–4.2 knots. For the former record interval, the streamer was towed from the ship rail while, for the latter record interval, the streamer was towed from the airgun sled. There were no other differences in the receiver array or recording system configuration. There is a significant increase in coherent ship-generated noise on the records (i.e., with the same amplitude spectrum as the coherent noise already described) when the streamer is towed from the gun sled versus when the streamer is towed from the ship rail. As in the previous examples, the influence of electromagnetic interference from power plants and engines onboard the ship.



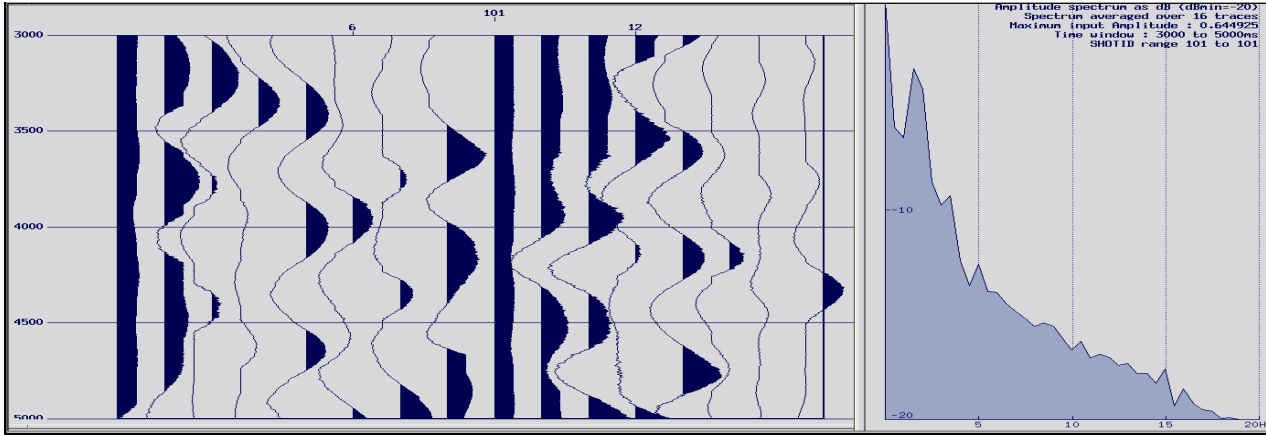


Figure 6.5 Noise record 101 of unfiltered traces 1 through 16 between 3.0 and 5.0 seconds (left) and the associated amplitude spectrum (right).

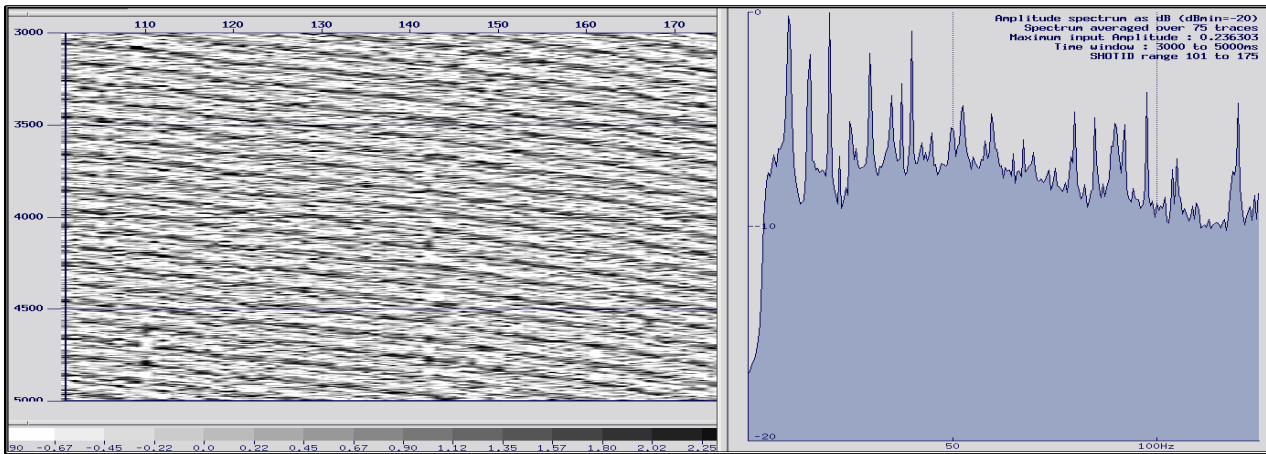


Figure 6.6 Variable density plot of near traces from records 101 to 175 after application of a 3.0/8.0 Hz low cut filter to remove swell noise. Automatic gain control has been applied to the traces to make the dipping events more visible.

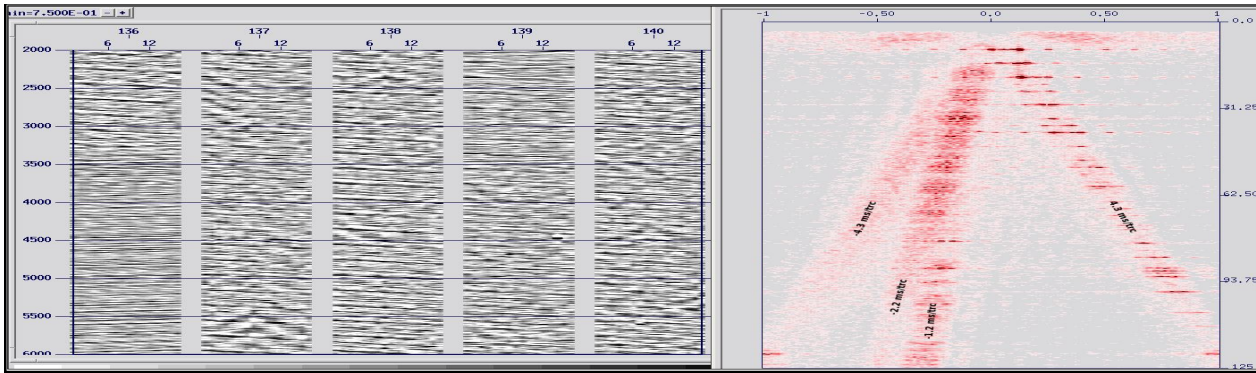


Figure 6.7 Variable density display of noise records 136 through 140 (left) after application of a 3.0/8.0 Hz low cut filter to remove swell noise. The F-K spectrum of these records is plotted on the right. Positive dips correspond to energy travelling from the near trace to the far trace. Note the strong peaks of ship-generated noise at the 5 and 2.5 Hz intervals listed in the text. Automatic gain control has been applied to make dipping events more visible.

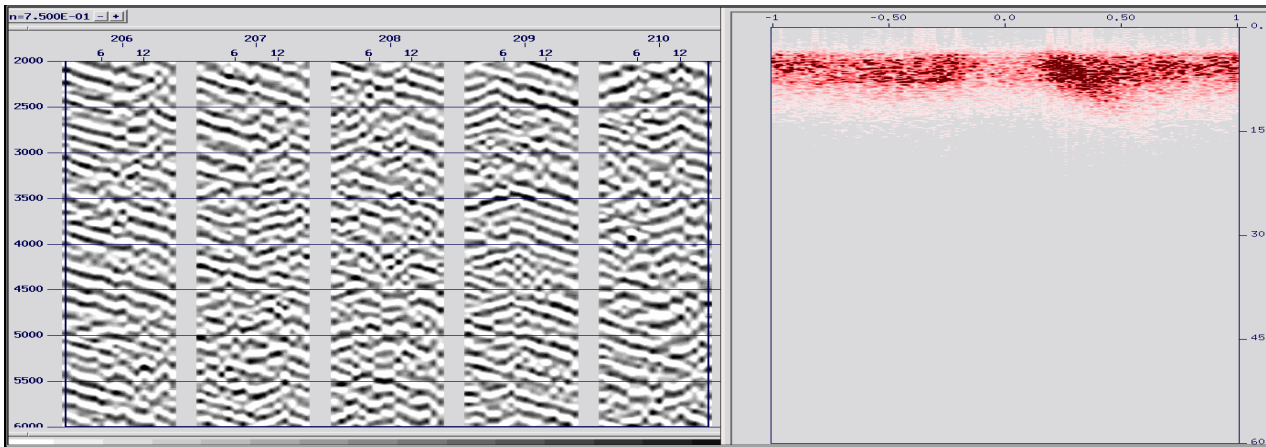


Figure 6.8 Variable density display of noise records 206 through 210 (left) after application of 3.0/8.0 low cut filter to remove swell noise. The F-K spectrum of these records is plotted to the right. Automatic gain control has been applied to make dipping events more visible.

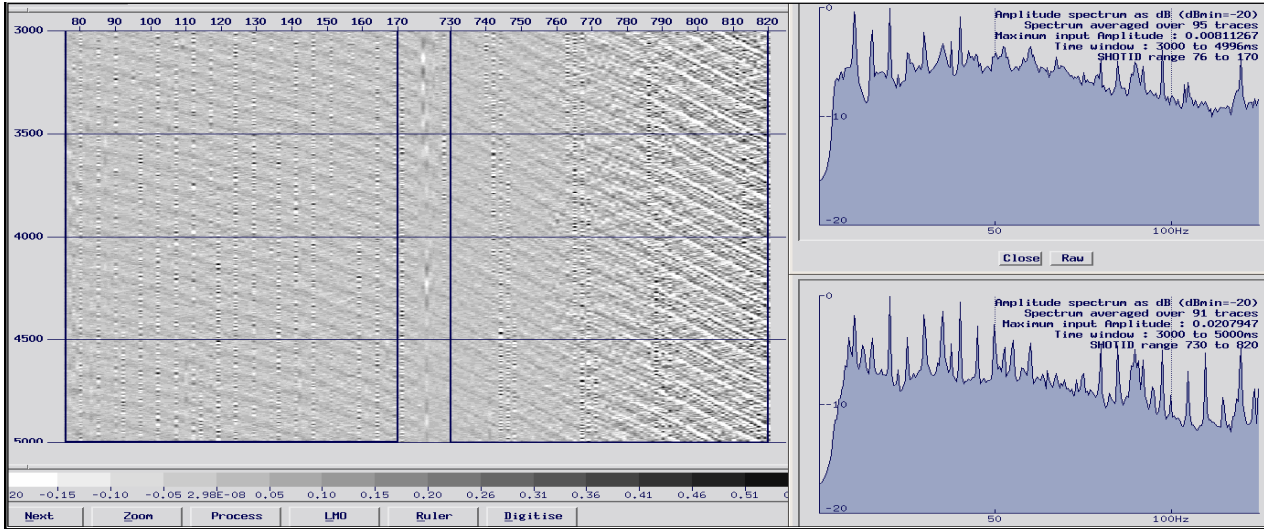


Figure 6.9 Variable density plot of near traces from noise records 76–175 and 721–820 (right) after application of 3.0/8.0 low cut filter to remove swell noise. No trace scaling has been applied. The amplitude spectrum for records 76–175 is plotted on the upper right, and the spectrum for records 721–820 is plotted in the lower right.

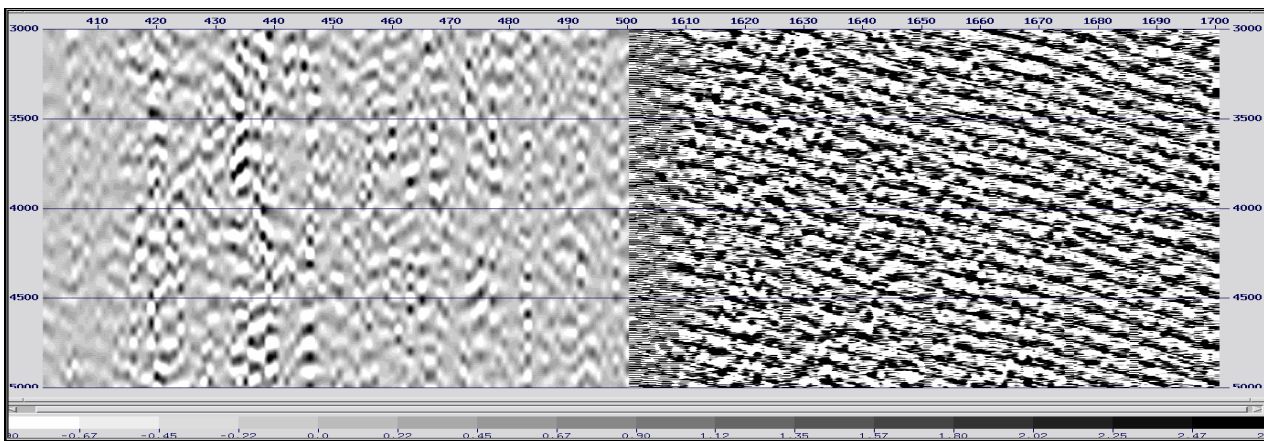


Figure 6.10 Near trace plot from noise records 401–500 (left) and 1601–1700 (right). No trace scaling has been applied.

## 6.7 Data Storage

Digital shot records were stored on magnetic disk drive, one file per shot record, in the Society of Exploration Geophysicists SEG-D 8058 Revision 1 format. Included in each SEG-D file is a 2048 byte (32 block) fixed header containing information logged from the ship's network within a 1 second window at each shot time. This information includes a GPS navigation string (GGA-string) with the Universal Coordinated Time (UTC) and the geographic position in degrees and decimal minutes (reference ellipsoid: World Geodetic System, 1984), water depth from the 12 kHz sounder (SDDBT-string), speed through the water (VWVHW-string), heading (HEHDT-string), speed over ground (GPVTG-string), and course over ground (also in the GPVTG-string).

As a backup, the SEG-D files were copied every half-hour onto a separate magnetic disk drive installed in the recording computer. The data were also transferred via Ethernet connection to a third magnetic disk drive attached to the computer used for processing. Upon completion of each line, all associated shot records and log files were copied onto two duplicate optical DVD disks for archival.

## 6.8 Data Quality Monitoring and Seismic Watchkeeping

During acquisition the CNT-2 user interface was used to automatically plot each shot record, the amplitude spectra of each trace, a bar graph of root-mean-squared (RMS) noise levels, a log of diagnostic messages, and a simple brute-stack record section. An example monitor display is shown on Figure 6.11. This provided immediate, shot-by-shot feedback on the GeoEel system performance and confirmation that the data were of acceptable quality. During seismic acquisition, watchkeepers kept a half-hourly log of the following system parameters: calendar day, UTC time, latitude, longitude, line segment, water depth, course over ground, heading, speed over ground, speed through water, ship's bubbler (on/off), streamer system (port/starboard), streamer leakage, streamer current, streamer voltage, streamer depth (inboard/outboard), seismic source system (port/starboard), shot number, total source volume, number of airguns, firing rate, and recording delay. An electronic copy of the watchkeepers' log is included with the cruise documentation.

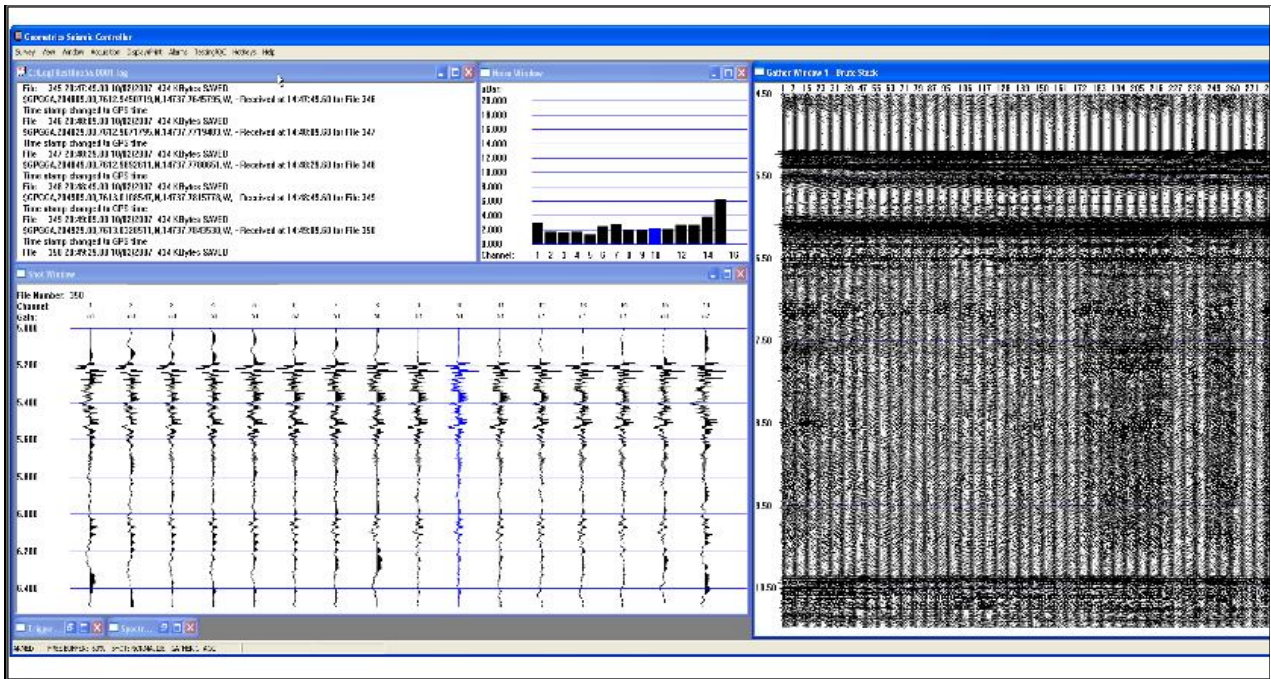


Figure 6.11 Screen capture of the CNT-2 graphical user interface showing a message log (top left), RMS noise chart (top middle), shot record (bottom left), and brute stack (right). The software also allows the frequency spectra of each trace to be monitored (not shown).

## 6.9 Data Processing

The Globe Claritas commercial software package (version 4.4) developed by the New Zealand Institute of Geological and Nuclear Sciences was used to process the seismic data during the cruise. This software proved to be a very efficient and versatile tool for evaluation of the data quality, assessment and verification of field acquisition parameters, and production of processed seismic sections. The data processing software was installed on a dual-processor laptop running under the Fedora Linux operating system (version 2.6.22). An external 500 gigabyte, universal serial bus hard-drive was used to store copies of both the raw and processed datasets.

### 6.9.1 Processing steps

Seismic data processing was performed incrementally in a series of steps to allow efficient design and testing of the various filter parameters. The basis sequence is outline below in Table 5.7.

**Table 6.7 Seismic data processing steps.**

<b>Job Name</b>	<b>Description</b>
01_segdin	<ul style="list-style-type: none"> <li>- read shot records from SEG-D formatted files</li> <li>- remove auxilliary traces (chn 17–20)</li> <li>- define offsets in trace headers</li> <li>- apply static correction for recording delay</li> <li>- antialias high cut filter (180/225Hz)</li> <li>- debias</li> </ul>
020_dump_hdr	<ul style="list-style-type: none"> <li>- dump navigation information from trace headers</li> <li>- interpolate missing navigation points</li> <li>- generate files for geometry and navigation</li> </ul>
024_calc_track_dist	<ul style="list-style-type: none"> <li>- calculate distance along track for brute stack binning</li> </ul>
026_water_depth_ahl	<ul style="list-style-type: none"> <li>- convert 12 kHz soundings to two-way time using 1500 m/s for trace headers</li> </ul>
030_brute_stack	<ul style="list-style-type: none"> <li>- bandpass filter (3/9/80/112 Hz)</li> <li>- <math>T^2</math> amplitude scaling</li> <li>- trace balance</li> <li>- 16:1 trace sum</li> <li>- assign traces to 50 m bins along track and stack</li> <li>- resample to 4 ms</li> </ul>
040_plot_brute	<ul style="list-style-type: none"> <li>- automatic gain control (250 ms window)</li> <li>- water column mute</li> <li>- generate 11x17" plots (30 traces/cm; 3.9 cm/s)</li> </ul>
050_edit_swell_strum	<ul style="list-style-type: none"> <li>- edit bad/noisy traces using RMS amplitude plots</li> <li>- low cut filter (3.0/8.0 Hz)</li> </ul>

<b>Job Name</b>	<b>Description</b>
	- F-K dip filter (> 2 ms/trace)
060_pick_sfpw	- digitize 1st and 2nd peaks of seafloor pulse
062_streamer_depth	- estimate trace by trace streamer depths using empirical best fit relation with the seafloor pulse width
064_decon_stack	- add geometry to trace header and design CMP bins at 50 spacings - T <sup>2</sup> amplitude scaling - trace balance - signature deconvolution using recorded source wavelets to convert records to minimum phase - removal of receiver ghost using estimated trace by trace receiver depths - predictive deconvolution (design window: 50–3500 ms beneath seafloor; filter length: 200 ms; gap length: 2nd zero crossing of autocorrelation function for each trace) - CMP sort and stack
070_stoltmig	- Stolt migration using constant velocity of 1800 m/s
080_finalize	- F-X deconvolution (filter length: 200 traces; filter apply: 100 traces; panel overlap: 40 traces; time window: 240 ms; time window overlap: 100 ms) - time-varying bandpass filter (linear transition from 2/7/80/120 Hz at 0-2 seconds below seafloor to 2/7/50/60 Hz at >4 seconds below seafloor) - 4 dB per second gain, relative to seafloor, to compensate for attenuation - gain of -14 dB applied to first primary seafloor multiple - 90° phase shift to convert to zero phase - 26 ms bulk shift (traces shift upwards) to datum of mean sea level as determined from 12 kHz sounder measurements - resample to 4 ms - water column mute - insert null traces for empty CMPs - insert CMP latitude/longitude coordinates (stored as 4-byte integers representing arc seconds x 100) into trace header byte locations 81 and 85.
090_plot	- generate 11x17" plots (30 traces/cm; 3.9 cm/s)

## 6.9.2 Estimation of Streamer Depths

The processing steps outlined above are fairly standard and are applied to most conventional multichannel datasets. However, further explanation of the derivation of streamer depths for deconvolution of the receiver ghost is warranted.

Typically the depth of active section is measured by transducers that are installed in streamer birds. For operation in ice-covered waters though, use of streamer birds is not feasible since they would be vulnerable to damage and may increase the risk of damage or loss for the entire streamer. Therefore the GeoEel active sections used for this project were manufactured with a single depth sensor inside each active section.

Two issues with the depth sensors arose during the survey. The first was that, though the depth sensor readings were continuously displayed by the CNT-2 software, the depth values were not written into the trace headers. It should be possible in future surveys to capture the depth information for the trace headers by broadcasting the values from the serial communications port of the seismic logger. However, there was not sufficient time during this survey to experiment and so the depth values were simply recorded in the observers' log at regular shot intervals.

The second issue is related to the fact that throughout the survey the streamer was negatively buoyant. Each time the ship was beset in ice or had to stop for operational reasons, the streamer would sink at a rate of approximately 100 m/hr. During acquisition of LSL0808a, the starboard streamer sank to a depth of greater than 70 m and the depth sensors stopped working. The depth sensors in the port streamer were also malfunctioning so, for the remainder of the survey, no streamer depth information was available.

Accurate measurement of the streamer depth is important for seismic surveys in ice-covered waters because changing ice conditions lead to frequent course deviations, variations in speed through the water, and even complete stops. As a result the streamer depth was observed to vary between 9 and 30 m, averaging about 20 m, during typical operations. In extreme circumstances, the depth was as shallow as 3 m due to strong prop wash, and deeper than 80 m when the ship was at a standstill. Furthermore, the near receiver group was typically 4–9 m shallower than the far receiver group.

Such significant variation in the receiver depths must be known on a shot by shot and trace by trace basis in order to remove the effects of the receiver ghost from the shot records. An estimation of the depth of each receiver group was derived by correlating the values recorded in the observers' log with the pulse width of the seafloor reflection (Figure 5.12). Using these estimated depths, the receiver ghost was deconvolved from the wavelet with reasonable success (Figure 5.13).



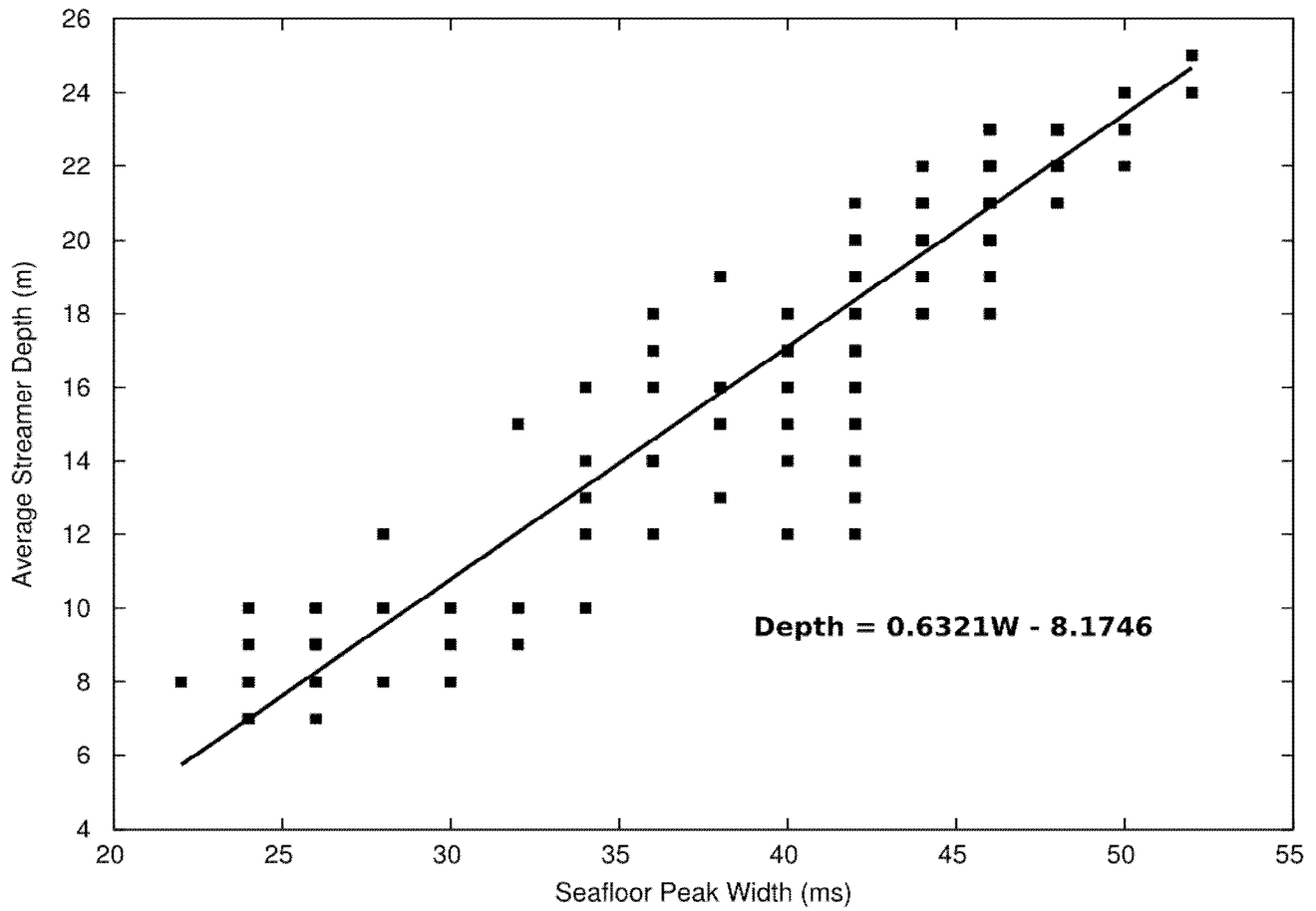
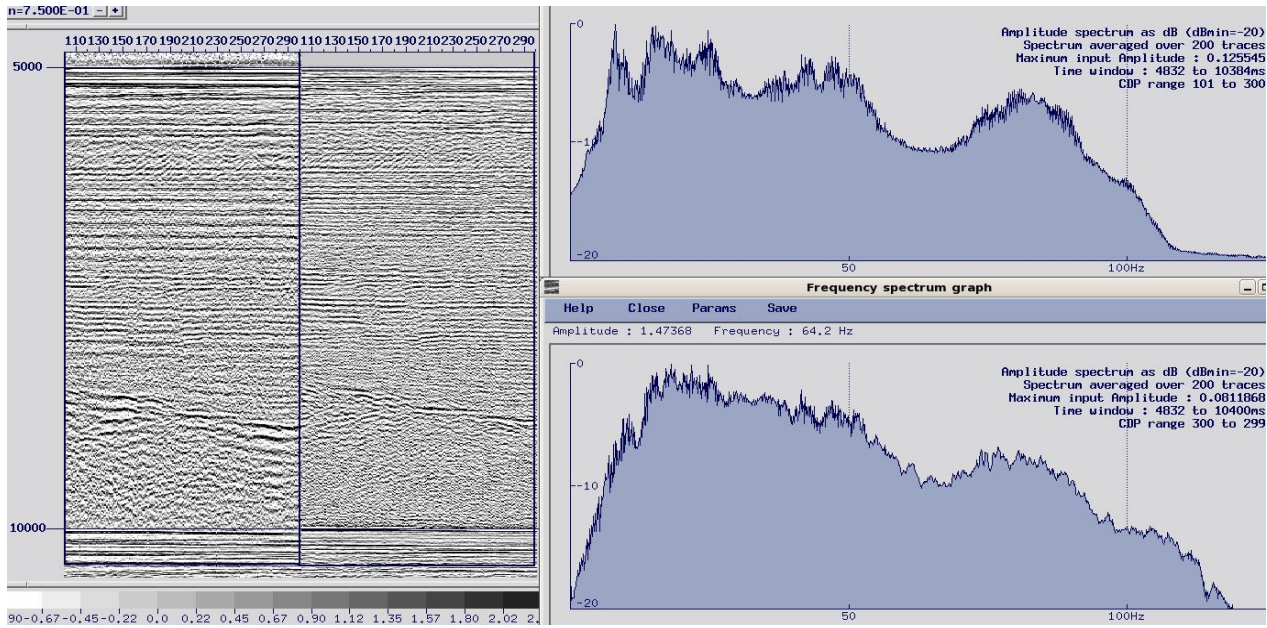


Figure 6.12 Streamer depth determined as an empirical function of seafloor peak width through least squares regression.



**Figure 6.13** Variable density plots of brute stack (left panel) and final stack (right panel) after source signature deconvolution and removal of receiver ghosts using streamer depths estimated on a trace by trace basis from the seafloor pulsewidth. For this record interval the streamer depths ranged between 19 and 22 m, as reported by the transducers in the streamer. This causes the receiver ghost notch in the amplitude spectrum of the brute stack (top right) between about 30 and 36 Hz. Deconvolution to remove the receiver ghost successfully boosts amplitudes in this band (bottom right).

## 6.10 Recommendations

1. Further investigate the mechanism by which ship-generated coherent noise is introduced into the seismic acquisition system and determine whether some form of electromagnetic shielding would be effective.
2. Purchase modular depth sensor units that can be added to the streamer at the connectors and which could be easily swapped out in the event of a malfunction. Ideally there should be depth sensors in proximity to the near receiver group, the middle receiver group, and the far receiver group.
3. Configure the CNT-2 acquisition system so that streamer depths are recorded in the correct trace headers on a shot by shot basis.
4. Lengthen the distance between the airgun sled and the adjacent repeater unit and determine whether this reduces coherent noise in the records.
5. A few months prior to the seismic program, obtain the latest version of the CNT-2 acquisition software and manuals, install two copies of the software on removable hard drives, and create an installation backup. The new software should be tested prior to the start of acquisition.
6. Replace the computer hard drives on the seismic data recorder before the next field season in case of sector damage due to the vibration of ice-breaking.

## 7 Marine Mammal Monitoring Report

In order to meet the requirements of the Inuvialuit Environmental Assessment and the Canadian Environmental Assessment Act, three marine mammal watchers were to work around the clock for the duration of the cruise. The ship the CGGS Louis S. St-Laurent sailed from Kugluktuk on August 22, 2008 and returned on October 2, 2008. The assessments require the air guns to be turned off in there is a marine mammal within 1 km of the ship.

The three marine mammal watchers were hired through the Paulatuk Hunters and Trappers Committee. Two of them, Jonah Nakimayak and John Ruben, had done the same task last year. A third observer, Dale Ruben, was new to the ship. A 24-hour a day watch schedule was set up that started as soon as the ship lifted anchor.

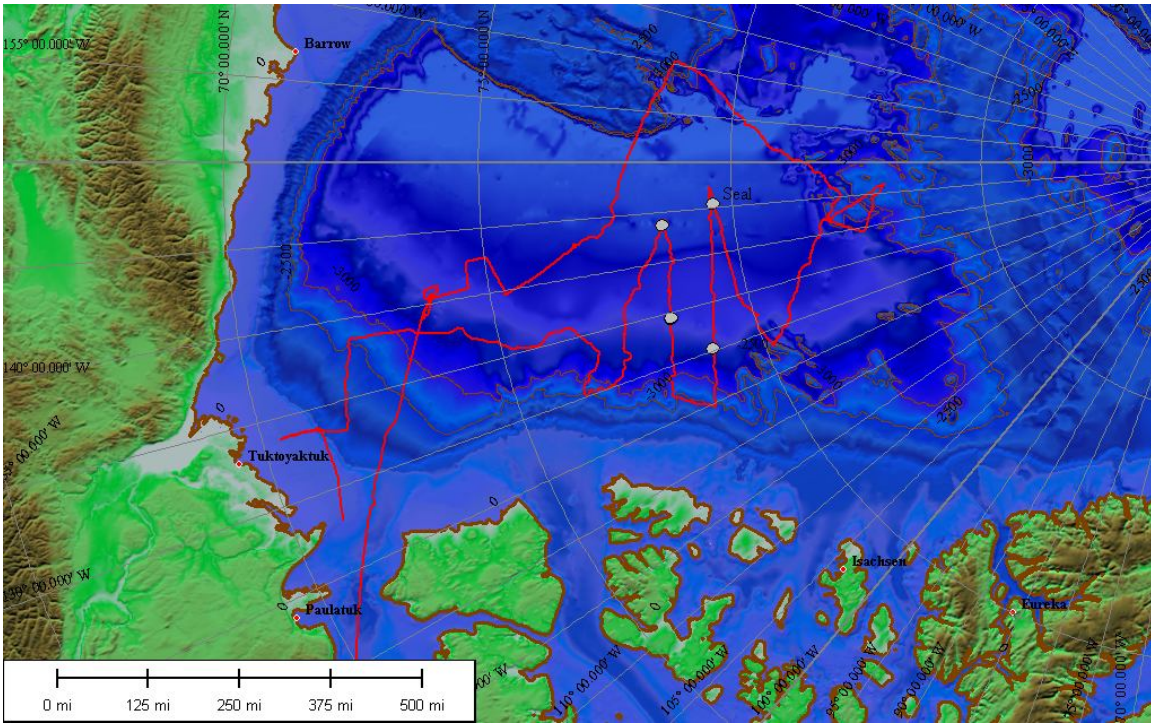
0800- 1600 Jonah Nakimayak  
1600-2400 John Ruben  
2400-0800 Dale Ruben

The monitors did the vast majority of their observations from the flying Bridge. It is a deck above the Bridge and is not covered. They were supplied with radios so that were able to contact the Bridge at any time. They were also welcomed to use the Bridge at any time. Generally they preferred working from the Flying Bridge because there were fewer distractions so they could concentrate. It had the additional advantage of being in the fresh air although at times it was cold. Log sheets were kept and annotated at half hour intervals. The digital logs are available from GSCA. This task required a stiff board below the log sheets. The Flying Bridge has a high rail and a special platform and chair were built by the carpenter to allow for the observer to sit if he chose to. For scientific ships in the future consideration should be given in the design for the work station of the marine mammal monitors.

The observers were on constant watch and reported all sightings as they occurred. When the airguns were to be fired, the Officer on the watch contacted the marine mammal observer on the Flying Bridge and requested permission to fire. Once this was given the firing sequence for the guns was initiated.

There were few sightings of marine mammals and the variety was limited; only seals and bears were seen. Almost all the bears were at distances of greater than 1.8 km or 1 nm. The marine mammal observers exhibited the ability to identify a bear long before any one else on the ship could sight them. On one occasion a bear was identified and it was announced to the ship's company. Many people came to the Bridge and for a full 15 minutes (1 nm with the ship travelling 4 knots) no other person could identify it. When the bear was within 1 nm range the Captain saw it and shortly thereafter the rest of the assembled group.

For the program next year Jonah would prefer an early time frame, August – September rather than September-October because the long days allow for better visibility. In addition, night vision glasses, stabilized binoculars and new GPS would facilitate the observation of marine mammals.



**Figure 7.1** the red line shows the ship's track. The grey dots are the position where marine mammals were sighted. There were three polar bears and one seal.

## 8 Overview of Ice Conditions

Deborah R. Hutchinson

The series of figures presented here are mosaics of the RADARSAT ice imagery at the approximate time of each track line, showing both satellite imagery and seismic or bathymetric track locations for each line. The dates and times for the images and the lines are displayed on each mosaic so that the match between the position of the ship and the actual conditions represented in the images can be approximated. Table 7.1 gives relevant details about each figure.

The images are recorded in order to show that many of the bends and jogs in the track lines are created by the ship steering to avoid large multiyear ice floes. A good example is the deviation south around a large ice floe on the left side of figure 3 (start of Line 8). In some instances, the track line appears to be slightly offset from an ice floe or a lead. This may be because the ice has moved relative to location of the track line.

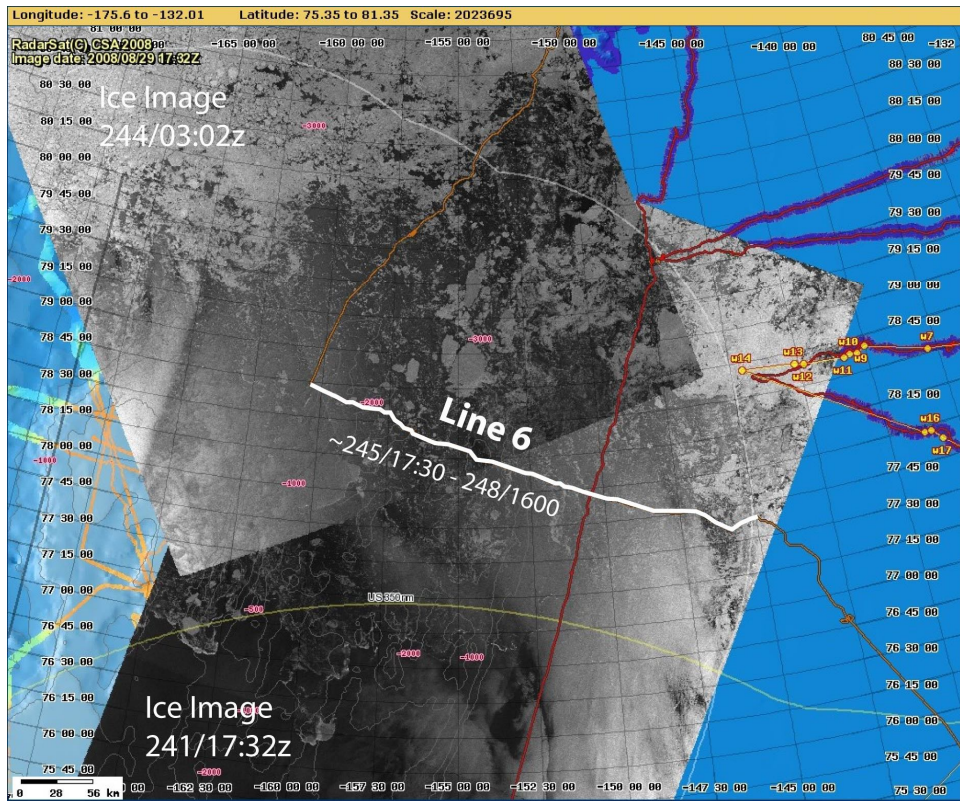
The source of the imagery is screen shots from the MapServer aboard *Healy*. The MapServer displays geo-referenced ice imagery together with ship tracks, buoy drift, and other relevant data being collected or monitored aboard the vessel. *Louis* ship tracks were displayed during the 2008 two-ship work, making the screen shots a convenient and easy way to capture the ice imagery and track line information.

Weather conditions during the cruise were excellent, with winds generally light and variable. Pressure conditions in the ice pack were sometimes severe and were therefore presumably created by far-field, rather than local forces. Thorough details about ice conditions are given in reports by Barbara Molyneaux, ice observer aboard the 2008 cruise.

**Table 8.1 Ice image details.**

Line No.	Fig. No.	JD/Time of Line <sup>1</sup>	Comment
1-5	None		Open water or light ice conditions
6	7.1	245/1730 – 248/1600	Louis as single ship
7	7.2	248/1600 – 250/2130	Louis as single ship
8	7.3	254/0600 – 256/0430	Healy breaking ice for Louis
9	7.4	257/2200 – 260/0030	Healy breaking ice for Louis
10	7.5	260/0530 – 262/1330	Healy breaking ice for Louis
11	7.6	265/0400 – 267/2230	Healy breaking ice for Louis
12	7.7	267/2230 – 269/1930	Healy breaking ice for Louis
Single7-8	7.8	250/2130 – 254/0600	Louis breaking ice for Healy
Multi8-9	7.9	256/0430 – 257/2200	Louis breaking ice for Healy
Multi10-11	7.10	262/1330 – 265/0400	Louis breaking ice for Healy
Multi12-End	7.11	269/1930 – 272/0430	Louis breaking ice for Healy

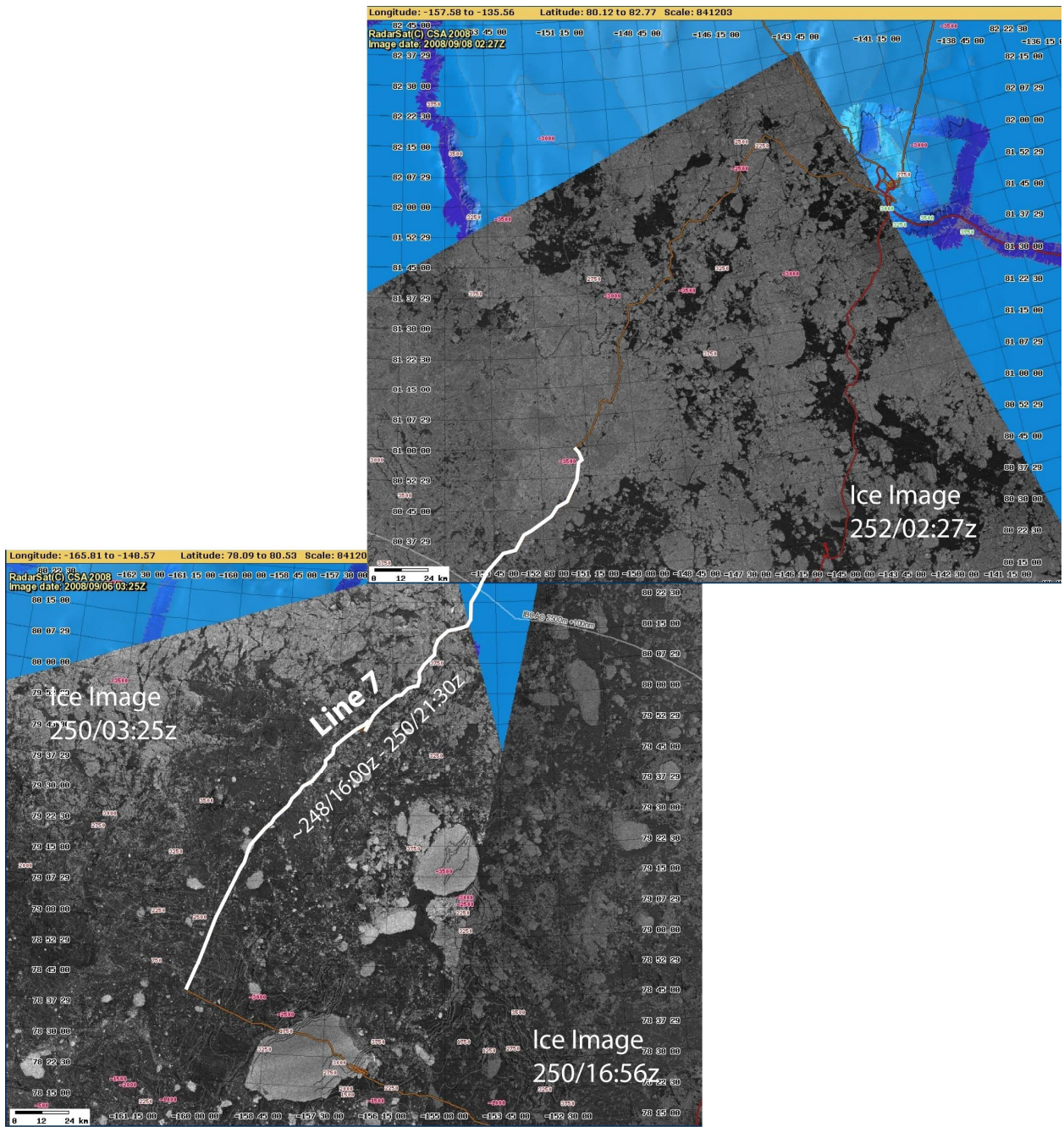
<sup>1</sup>JD: Julian Day. Time: GMT. Times approximate to closest half hour.



Source: USCGC Healy MapServer

Figure 8.1 Ice imagery along Line 6.





Source: USCGC Healy MapServer

Figure 8.2 Ice imagery along Line 7.

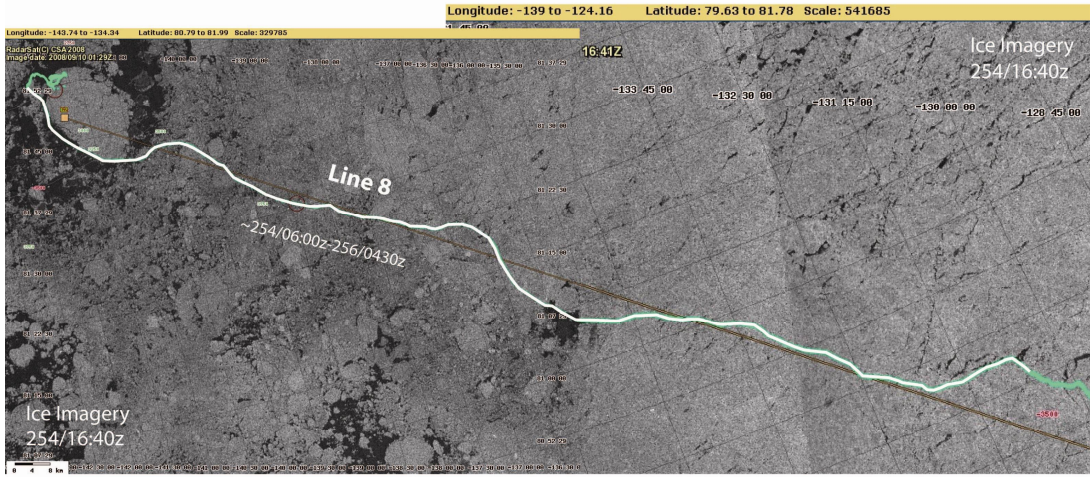


Figure 8.3 Ice imagery along Line 8.

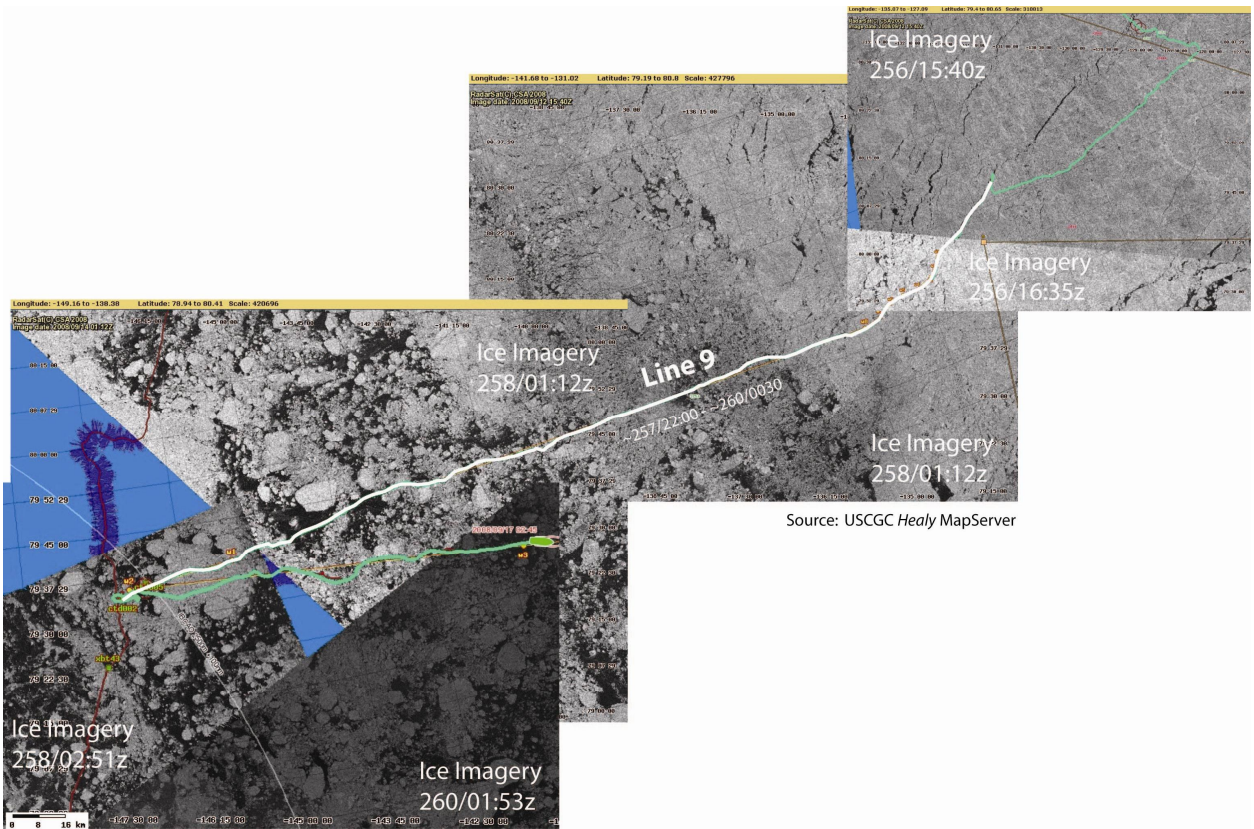
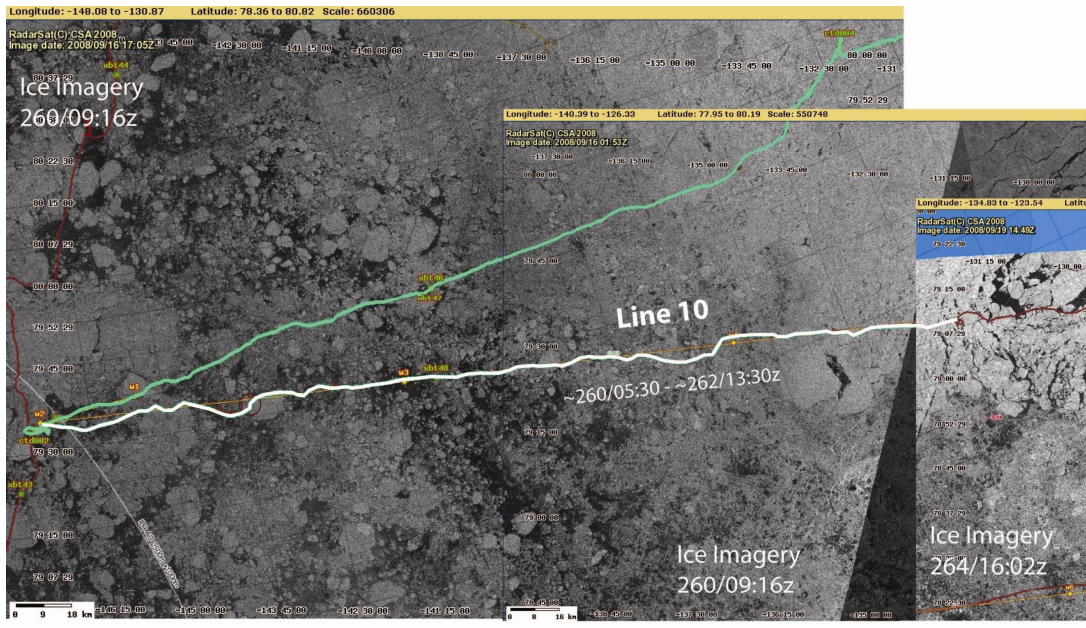
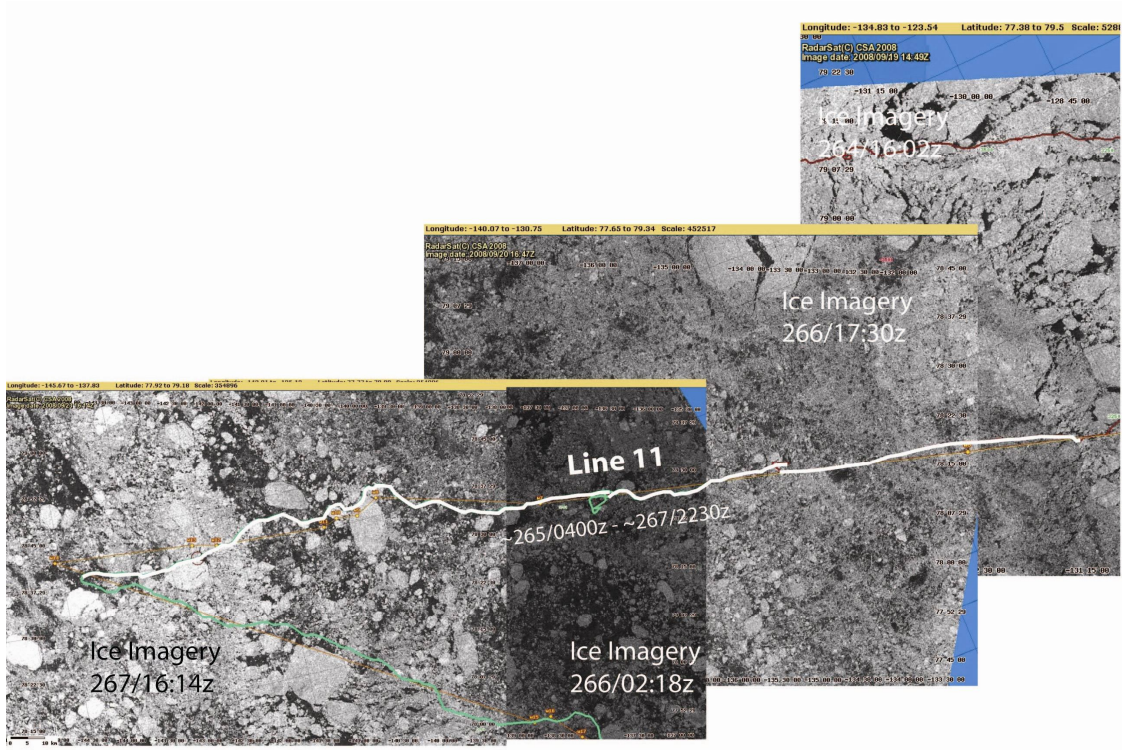


Figure 8.4 Ice imagery along Line 9.



Source: USCGC Healy MapServer

Figure 8.5 Ice imagery along Line 10.



Source: USCGC Healy MapServer

Figure 8.6 Ice imagery along Line 11.

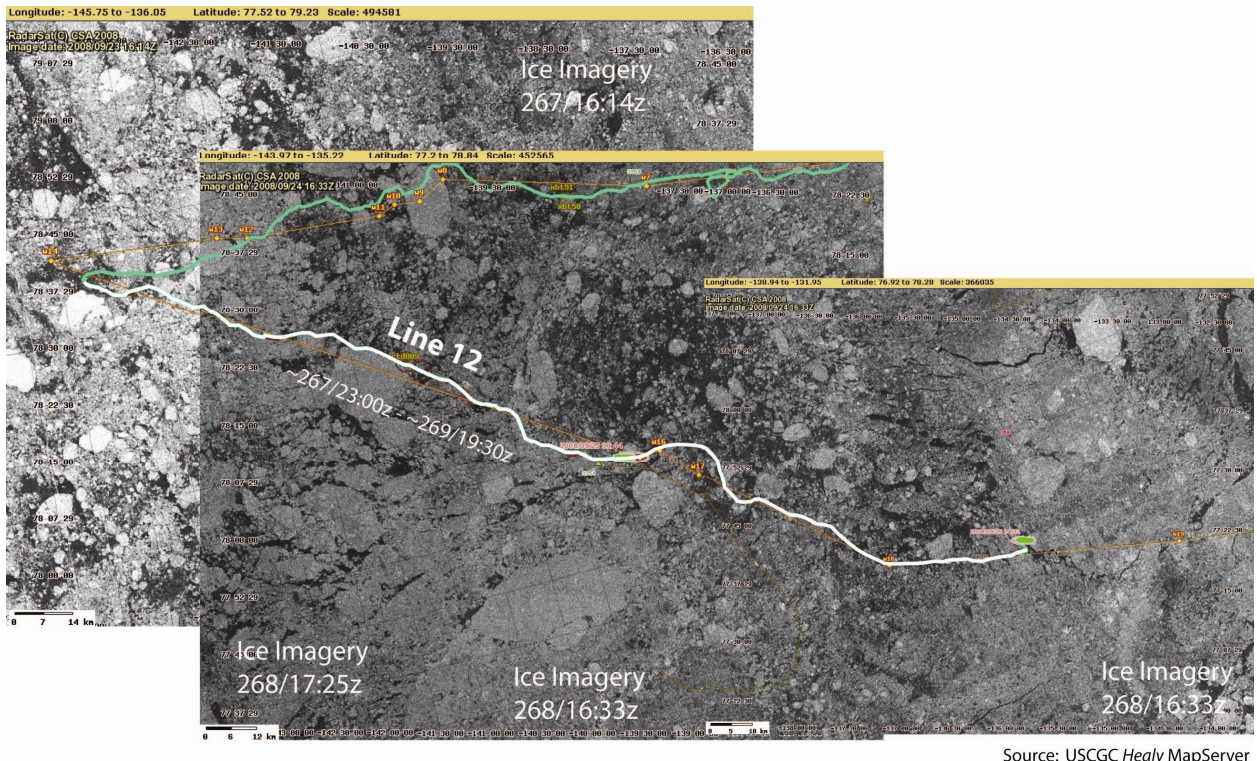


Figure 8.7 Ice imagery along Line 12.

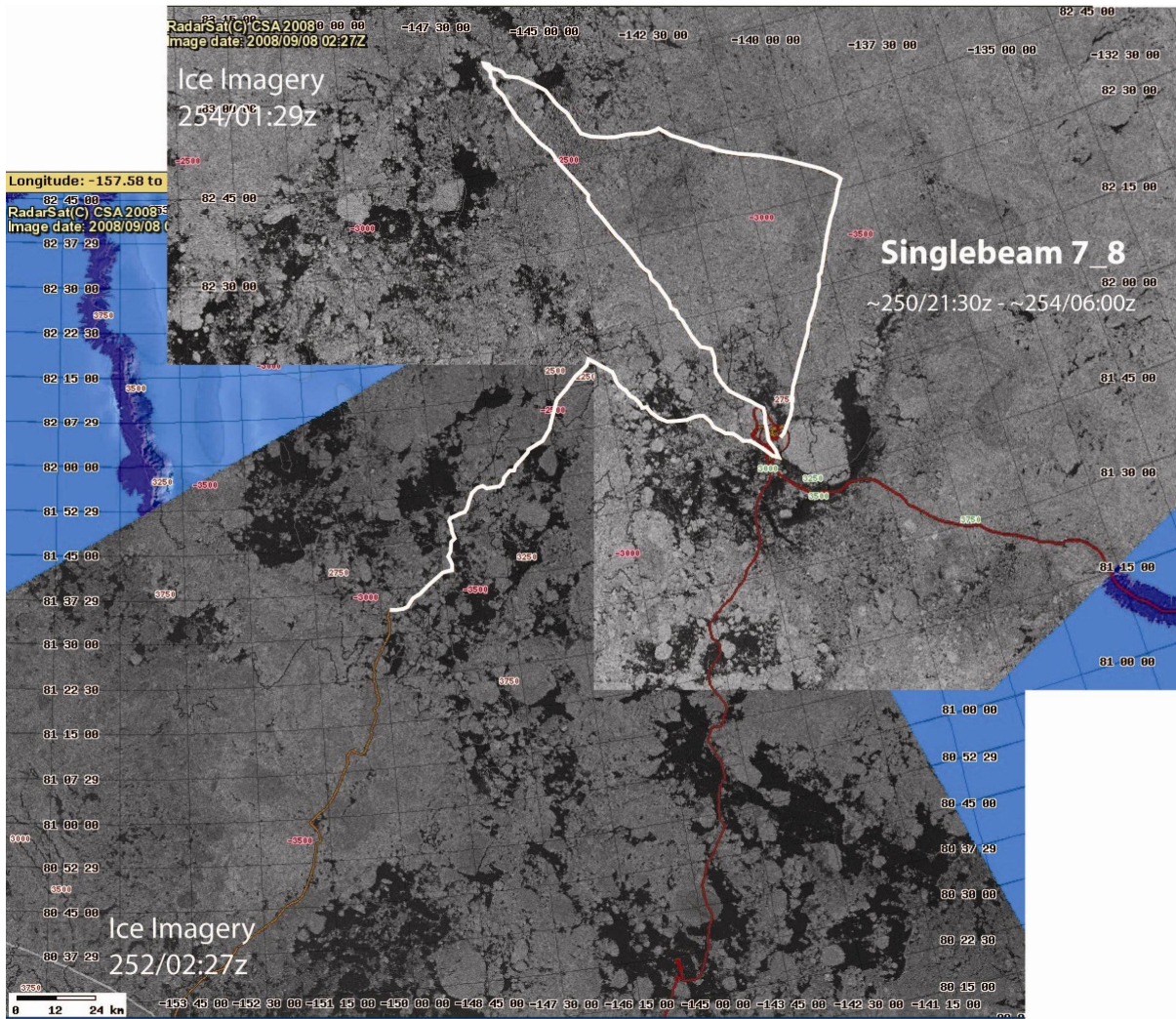


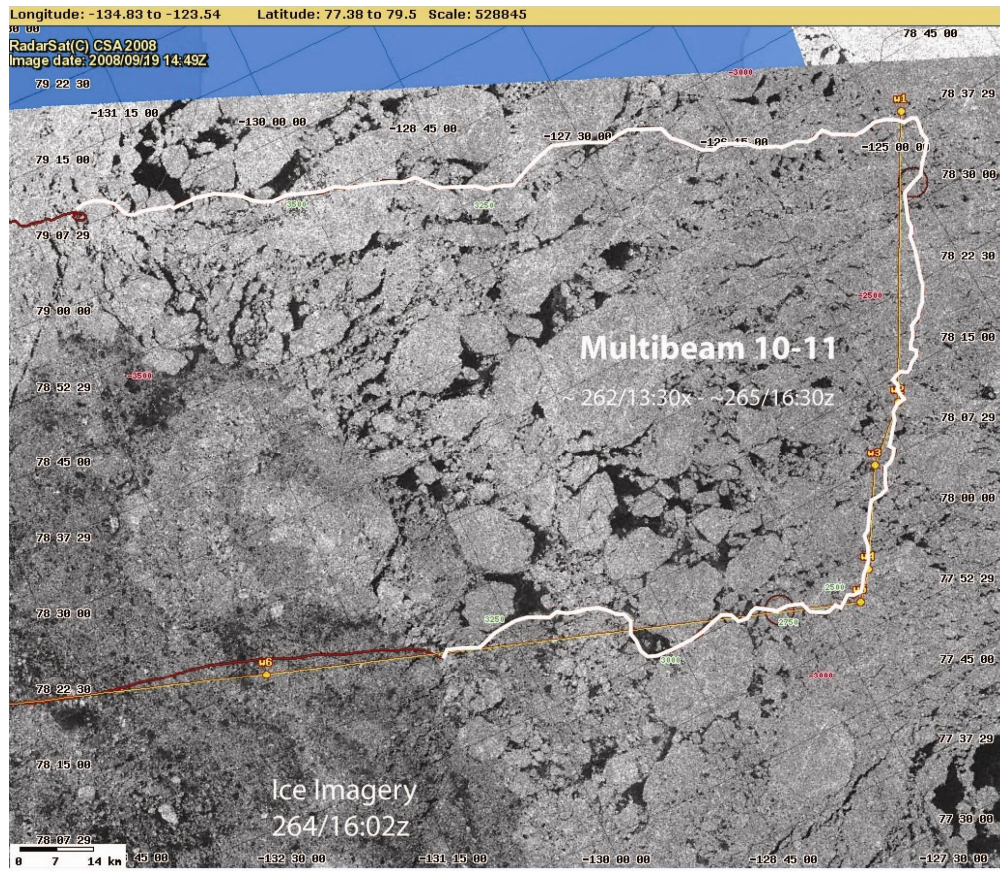
Figure 8.8 Ice imagery along singlebeam tracks between Lines 7 and 8.



Source: USCGC Healy MapServer

Figure 8.9 Ice imagery along multibeam track between Lines 8 and 9.





Source: USCGC Healy MapServer

Figure 8.10 Ice imagery along multibeam track between Lines 10 and 11.

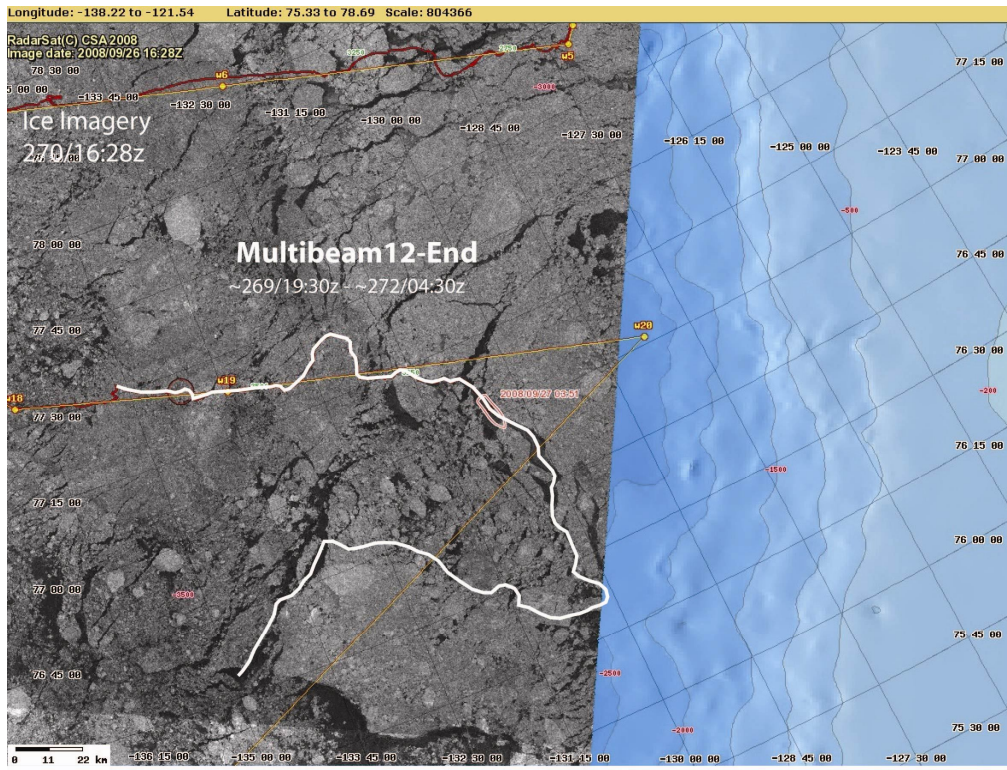


Figure 8.11 Ice imagery along multibeam tracks between Line 12 and the end of two-ship operations.

## 9 XCTD Report

Shigeto Nishino

Japan Agency for Marine-Earth Science and Technology (JAMSTEC)

### 9.1 Objective

The goal of the project is to measure temperature and salinity profiles in the Arctic Ocean to better understand water mass distributions and the ocean circulation, which are related to the sea ice distribution, heat and freshwater transports, biogeochemical cycles, and their temporal variations in the changing Arctic climate system.

### 9.2 Method

XCTD (eXpendable Conductivity-Temperature-Depth) profiler probes (Tsurumi-Seiki Co., Ltd.) were launched by a hand launcher LM-3A (Tsurumi-Seiki Co., Ltd.) from the stern of the ship to measure vertical profiles of water temperature and salinity to a depth of 1000m (or the bottom in shallower water). The data is communicated back to a digital data converter (MK-130, Tsurumi-Seiki Co., Ltd.) and a computer onboard the ship by a fine wire which breaks when the probe reaches maximum depth.

According to manufacturer's nominal specifications, the range and accuracy of parameters measured by the XCTD are shown in Table 8.1.

**Table 9.1 Manufacturer's specifications for XCTD probes (Tsurumi-Seiki Co., Ltd.).**

Parameter	Range	Accuracy
Conductivity	0 ~ 60 ms/cm	+/- 0.03 ms/cm
Temperature	-2 ~ 35 °C	+/- 0.02 °C
Depth	0 ~ 1000m	Greater of 5m or 2% water depth

During the cruise, 67 XCTD casts were made. Table 8.2 summarizes all casts. Four XCTDs (numbers 21, 28, 34, and 59) failed to obtain data. The possible reasons for these failures are as follows:

- Cast 21: The probe was trapped in the bubbles of the seismic gear.
- Cast 28: The probe was dropped on the ice.
- Cast 34: Unknown.
- Cast 59: The cast wire contacted the cable of the seismic gear.

**Table 9.2 LSSL2008-31 (UNCLOS) XCTD Log.**

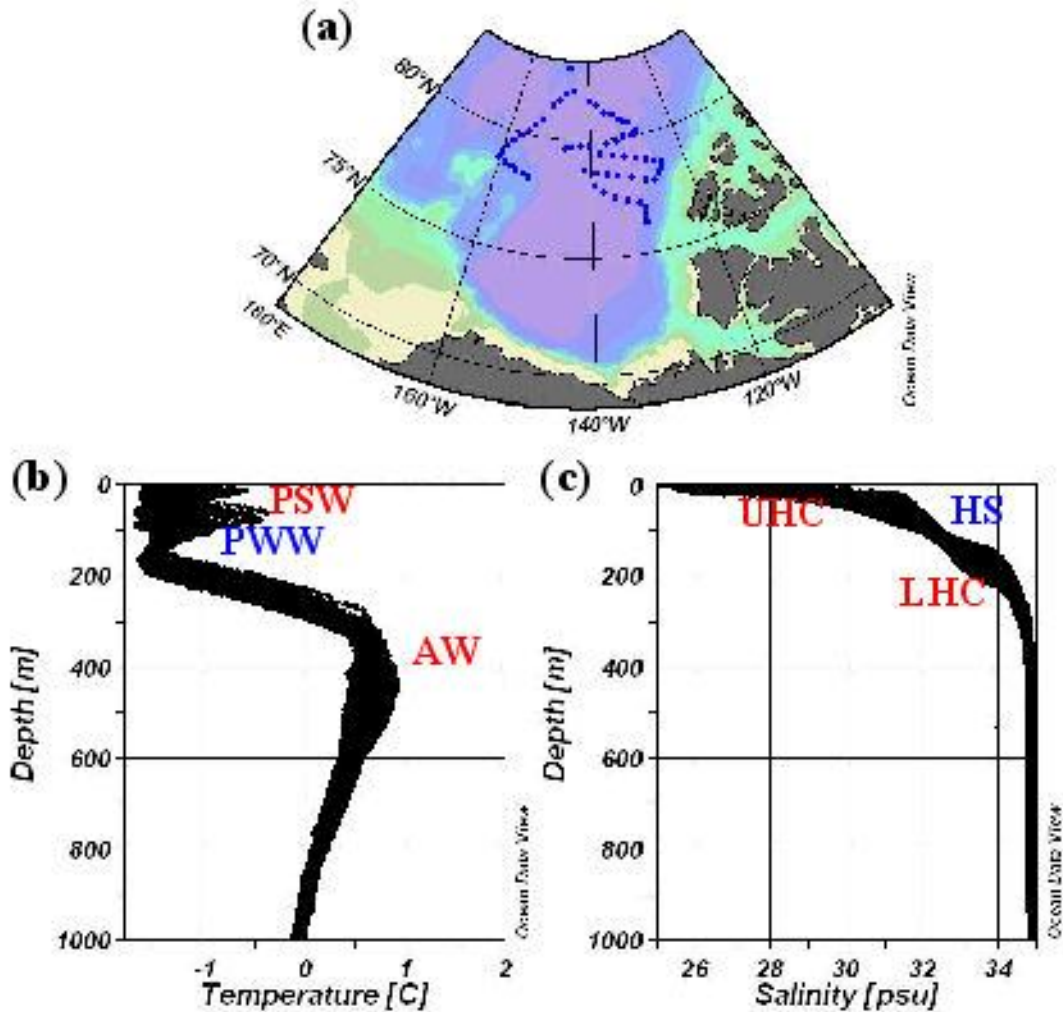
Station	Month	Day	Time(UTC)	Latitude	Longitude	Depth	File name	Probe number
XCTD-001	Sep	3	04:11:09	7811.18386N	15321.25426W	2305	200831-XCTD-001	07022702
XCTD-002	Sep	3	09:32:32	7817.72095N	15436.83758W	987	200831-XCTD-002	07022701
XCTD-003	Sep	3	15:47:57	7823.07113N	15607.98987W	2284	200831-XCTD-003	07022694
XCTD-004	Sep	4	04:36:58	7832.36305N	15720.01480W	3863	200831-XCTD-004	07022697

XCTD-005	Sep	4	10:03:17	7837.25841N	15849.23832W	2882	200831-XCTD-005	07022700
XCTD-006	Sep	4	15:33:36	7843.48204N	16019.78835W	777	200831-XCTD-006	07022703
XCTD-007	Sep	4	20:56:23	7900.45587N	15959.09422W	2470	200831-XCTD-007	07022704
XCTD-008	Sep	5	01:42:18	7917.90788N	15923.91211W	3304	200831-XCTD-008	07022705
XCTD-009	Sep	5	08:48:41	7936.32950N	15811.09241W	3592	200831-XCTD-009	07095703
XCTD-010	Sep	5	15:11:21	7952.42787N	15649.44059W	3841	200831-XCTD-010	07095700
XCTD-011	Sep	6	02:27:30	8009.33609N	15517.09565W	3856	200831-XCTD-011	07095697
XCTD-012	Sep	6	09:14:57	8027.31814N	15404.95833W	3858	200831-XCTD-012	07095694
XCTD-013	Sep	6	15:45:04	8042.92803N	15220.58081W	3849	200831-XCTD-013	07095695
XCTD-014	Sep	7	05:20:46	8124.66555N	15013.07831W	3838	200831-XCTD-014	07095698
XCTD-015	Sep	7	10:09:54	8139.83293N	14832.29975W	3710	200831-XCTD-015	07095699
XCTD-016	Sep	7	15:18:24	8156.78193N	14653.74800W	3461	200831-XCTD-016	07095702
XCTD-017	Sep	7	21:09:19	8204.70390N	14435.47576W	3100	200831-XCTD-017	07095701
XCTD-018	Sep	8	20:45:17	8302.87882N	14629.69984W	2626	200831-XCTD-018	07095705
XCTD-019	Sep	10	13:21:46	8140.52335N	14006.27735W	3787	200831-XCTD-019	07095704
XCTD-020	Sep	10	19:08:23	8127.27136N	13813.49436W	3779	200831-XCTD-020	07116785
XCTD-021	Sep	11	01:35:39	8114.63984N	13625.06351W	3766	200831-XCTD-021	07116786
XCTD-022	Sep	11	03:25:19	8108.74165N	13600.63809W	3763	200831-XCTD-022	07116787
XCTD-023	Sep	11	08:41:45	8100.69912N	13411.18706W	3731	200831-XCTD-023	07116781
XCTD-024	Sep	11	16:22:17	8046.31553N	13225.54761W	3678	200831-XCTD-024	07116782
XCTD-025	Sep	11	20:31:18	8042.66184N	13149.39993W	3649	200831-XCTD-025	07116784
XCTD-026	Sep	12	07:39:42	8037.25166N	13022.41324W	3635	200831-XCTD-026	07116778
XCTD-027	Sep	12	17:22:22	8013.73083N	12836.19396W	3200	200831-XCTD-027	07116779
XCTD-028	Sep	13	05:10:31	8006.17545N	12904.61041W	3192	200831-XCTD-028	07116780
XCTD-029	Sep	13	05:13:15	8006.16608N	12904.72743W	3198	200831-XCTD-029	07116775
XCTD-030	Sep	13	09:26:06	8003.03472N	13008.88188W	3061	200831-XCTD-030	07116776
XCTD-031	Sep	13	09:30:05	8003.02925N	13008.92747W	3061	200831-XCTD-031	07116777
XCTD-032	Sep	13	16:37:49	8001.45963N	13204.39420W	3625	200831-XCTD-032	07022672
XCTD-033	Sep	13	17:56:31	8004.59292N	13201.89855W	3643	200831-XCTD-033	07022671
XCTD-034	Sep	14	06:01:48	7951.43139N	13347.23948W	3711	200831-XCTD-034	07022670
XCTD-035	Sep	14	06:07:02	7951.39436N	13347.61577W	3711	200831-XCTD-035	07022675
XCTD-036	Sep	14	15:02:55	7948.78687N	13620.98777W	3764	200831-XCTD-036	07022674
XCTD-037	Sep	14	15:09:24	7948.80897N	13622.67110W	3764	200831-XCTD-037	07022673
XCTD-038	Sep	15	03:21:15	7945.13261N	14016.45167W	3812	200831-XCTD-038	07022678
XCTD-039	Sep	15	09:07:59	7944.16300N	14215.96166W	3834	200831-XCTD-039	07022677
XCTD-040	Sep	15	17:01:10	7939.23661N	14442.35738W	3848	200831-XCTD-040	07022676
XCTD-041	Sep	15	21:34:49	7937.31596N	14609.14506W	3853	200831-XCTD-041	07022681
XCTD-042	Sep	17	11:47:13	7925.03934N	13748.47403W	3784	200831-XCTD-042	07022680
XCTD-043	Sep	17	21:15:43	7919.05392N	13503.09923W	3743	200831-XCTD-043	07022679
XCTD-044	Sep	18	07:43:35	7910.12616N	13235.06548W	3618	200831-XCTD-044	07022660
XCTD-045	Sep	18	18:41:45	7901.72165N	13006.48338W	3544	200831-XCTD-045	07022659
XCTD-046	Sep	18	18:46:54	7901.69948N	13006.41231W	3544	200831-XCTD-046	07022658
XCTD-047	Sep	19	02:33:25	7853.15352N	12801.69827W	3247	200831-XCTD-047	07022663
XCTD-048	Sep	19	06:26:05	7846.25349N	12634.55054W	3043	200831-XCTD-048	07022662
XCTD-049	Sep	19	10:46:39	7839.45865N	12500.03829W	2750	200831-XCTD-049	07022661
XCTD-050	Sep	19	19:51:44	7823.80760N	12521.87399W	2480	200831-XCTD-050	07022666
XCTD-051	Sep	20	02:45:57	7814.59404N	12603.06406W	2380	200831-XCTD-051	07022665
XCTD-052	Sep	20	13:56:32	7756.33267N	12719.20881W	2093	200831-XCTD-052	07022664

XCTD-053	Sep	20	20:39:49	7803.06020N	12903.92673W	2987	200831-XCTD-053	07022669
XCTD-054	Sep	21	07:04:17	7815.34776N	13134.87744W	3556	200831-XCTD-054	07022668
XCTD-055	Sep	21	17:13:54	7823.40014N	13424.00336W	3686	200831-XCTD-055	07022667
XCTD-056	Sep	22	08:51:37	7829.93610N	13640.83777W	3767	200831-XCTD-056	07012628
XCTD-057	Sep	23	03:02:08	7834.53998N	13856.12252W	3564	200831-XCTD-057	07012629
XCTD-058	Sep	23	12:21:06	7841.56932N	14124.12531W	3831	200831-XCTD-058	07012630
XCTD-059	Sep	23	21:56:37	7838.86133N	14403.82384W	3852	200831-XCTD-059	07012625
XCTD-060	Sep	25	01:34:13	7801.05032N	13928.72542W	3789	200831-XCTD-060	07012626
XCTD-061	Sep	25	10:13:32	7746.01853N	13733.57718W	3735	200831-XCTD-061	07012627
XCTD-062	Sep	25	20:01:33	7729.50003N	13521.53265W	3648	200831-XCTD-062	07012622
XCTD-063	Sep	26	20:00:21	7719.68962N	13257.86411W	3504	200831-XCTD-063	07012623
XCTD-064	Sep	27	01:57:41	7710.32341N	13056.00216W	3233	200831-XCTD-064	07012624
XCTD-065	Sep	27	04:55:38	7655.11546N	13009.61637W	2562	200831-XCTD-065	07012619
XCTD-066	Sep	27	08:00:49	7636.02942N	13021.60456W	2709	200831-XCTD-066	07012620
XCTD-067	Sep	27	11:51:24	7618.78223N	13020.72371W	2530	200831-XCTD-067	07012621

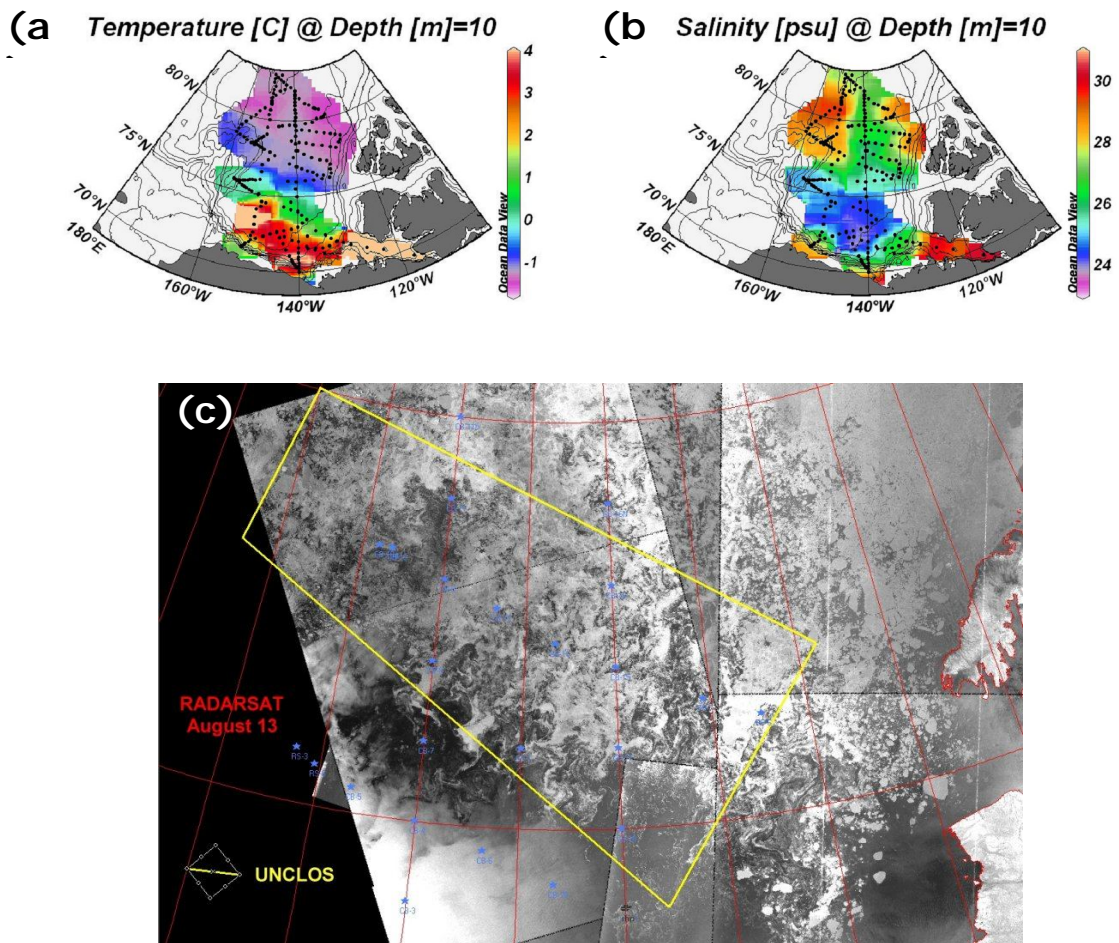
### 9.3 Preliminary Results

Figures 8.1a, 8.11b, and 8.1c summarize XCTD stations, temperature and salinity profiles at all the stations, respectively. Typical temperature profiles show temperature maxima at 15 – 20 m, ~ 80 m, and ~ 400 m, and temperature minima between them. The surface temperature maximum (15 – 20 m) is caused by the surface heating, and the subsurface temperature maximum (~ 80 m) is the influence of warm water from the Pacific Ocean called Pacific summer water (PSW). The temperature maximum at ~ 400 m results from the circulation of Atlantic water. The temperature minimum below the heated surface water is a remnant of winter cooling. The temperature minimum between the temperature maxima of PSW and Atlantic water is caused by the spreading of Pacific winter water (PWW) into the western Arctic Ocean. Salinity profiles indicate a sharp upper halocline between surface fresh water, which is composed of meteoric (river and precipitation) and sea-ice melt waters, and PSW. A halostad is found at depths of PWW. The halostad is caused by deep convection accompanied by the winter cooling for the formation of PWW. A halocline between PWW and Atlantic water is called lower halocline. The lower halocline water is derived from the eastern Arctic Ocean.



**Figure 9.1 (a) XCTD stations, (b) temperature and (c) salinity profiles at all the XCTD stations in this cruise (LSSL2008-31, UNCLOS). In (b) and (c), letters are abbreviations for Pacific summer water (PSW), Pacific winter water (PWW), AW (Atlantic water), UHC (upper halocline), LHC (lower halocline), and HS (halostad).**

Figures 2a and 2b show temperature and salinity distributions, respectively, at a depth of 10 m. For the illustrations, the XCTD data were combined with the CTD and XCTD data in the previous cruise (LSSL2008-30, JOIS). A region with higher temperature and lower salinity south of  $\sim 77^\circ \text{N}$  at the  $150^\circ \text{W}$  meridian and south of  $\sim 75^\circ \text{N}$  at the  $140^\circ \text{W}$  meridians corresponds to an open water region (Figure 2c). North of the region, sea-ice covers the ocean. The surface temperature and salinity distributions are very consistent with the sea-ice distribution.



**Figure 8.2 (a) Temperature and (b) salinity distributions at a depth of 10 m, and (c) RADARSAT sea-ice image on 13 August 2008. For the illustrations of (a) and (b), the XCTD data were combined with the CTD and XCTD data in the previous cruise (LSSL2008-30, JOIS).**

Figures 8.3a and 8.3b show distributions of temperature on an isohaline surface of  $S = 32$  and dynamic height from 1000 m to 100 m, the depth of which roughly corresponds to the level of  $S = 32$  isohaline surface. For the illustrations, the XCTD data were combined with the CTD and XCTD data in the previous cruise (LSSL2008-30, JOIS). Furthermore, the data from R/V Mirai of JAMSTEC in 2004 (Shimada, 2004) were combined to compare our results with that of the western part of the Canada Basin. The  $S = 32$  isohaline surface is located at the bottom of Pacific summer water (PSW), which spreads east of the Chukchi Plateau (Shimada et al., 2001; See also red allows in Figure 8.3b). West of the Chukchi Plateau, temperature minimum water occupies along the  $S = 32$  isohaline surface and the water is thought to be PSW that has been cooled in winter on its way to the Chukchi Abyssal Plain (Nishino et al., 2008). On the  $S = 32$  isohaline surface, low temperature water was found not only in the Chukchi Abyssal Plain (western part of the Canada Basin) but

also northern and eastern parts of the Canada Basin (Figure 8.3a). Based on the dynamic height, anticyclonic circulation (blue arrows in Figure 3b) seems to carry the lowest temperature water in the Chukchi Abyssal Plain into the northern and eastern parts of the Canada Basin. The temperature minimum water of  $S = 32$  in the Chukchi Abyssal Plain has relatively high nutrients, because the water would have passed through the western Chukchi Sea where the nutrients are regenerated from the bottom of the shelf. Therefore, the water would play an important role in biological activities in the Canada Basin, if the sea-ice retreats to the northern part of the Canada Basin.

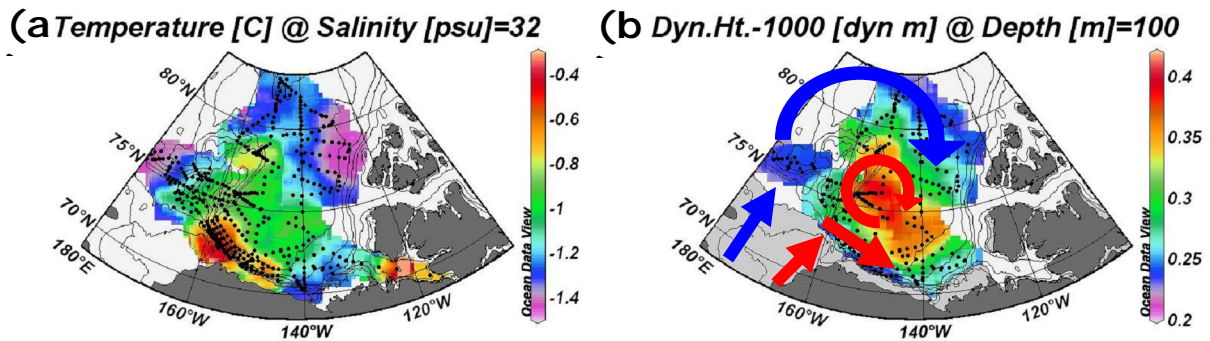


Figure 8.3 (a) Temperature on an isohaline surface of  $S = 32$  and (b) dynamic height at a depth of 100 m relative to 1000 m. In (b), schematic circulation patterns on the Pacific summer water and its modified water by winter cooling are shown by red and blue arrows, respectively.

## 9.4 Data Management Policy

The XCTD observation is conducted under the program of JWACS (Joint Western Arctic Climate Studies) between JAMSTEC and DFO. Data will be shared among the participants of this cruise (LSSL2008-31, UNCLOS). Sharing the data with third party shall be by mutual consent between JAMSTEC and IOS/DFO.

Science coordinators

JAMSTEC: Koji Shimada (shimadak@jamstec.go.jp) \*1

IOS/DFO: Eddy Carmack (Eddy.Carmack@dfo-mpo.gc.ca)

\*1 Now at Tokyo University of Marine Science and Technology; koji@kaiyodai.ac.jp