



**GEOLOGICAL SURVEY OF CANADA
OPEN FILE 4987**

**Cruise Matthew 2003069 Geophysical and Multibeam
Bathymetry Surveys of Summerside, PEI, and Miramichi, NB,
24 October – 7 November 2003**



Lighthouse on Indian Spit in the entrance to Summerside PEI

D.R. Parrott, T. Milligan and G. Bugden

2010



Natural Resources
Canada

Ressources naturelles
Canada

Canada



**GEOLOGICAL SURVEY OF CANADA
OPEN FILE 4987**

**Cruise Matthew 2003069 Geophysical and Multibeam
Bathymetry Surveys of Summerside, PEI, and Miramichi, NB,
24 October – 7 November 2003**



Lighthouse on Indian Spit in the entrance to Summerside PEI

D.R. Parrott, T. Milligan and G. Bugden

2010

©Her Majesty the Queen in Right of Canada 2010

This publication is available from the Geological Survey of Canada Bookstore (http://gsc.nrcan.gc.ca/bookstore_e.php).
It can also be downloaded free of charge from GeoPub
(<http://geopub.mcan.gc.ca/>).

Parrott, D.R., Milligan, T., and Bugden, G. 2010. Cruise Matthew 2003069 Geophysical and Multibeam Bathymetry Surveys of Summerside, PEI, and Miramichi, NB, 24 October – 7 November 2003; Geological Survey of Canada, Open File 4987, 43 p.

Open files are products that have not gone through the GSC formal publication process.

Background	5
Survey Overview	7
Data Acquisition and Processing	8
Sidescan Sonar	8
IKB Technologies Seistec Sub-bottom profiler	9
Digital Data Acquisition	10
Navigation	11
Multibeam Bathymetry	11
Multibeam Backscatter	12
Acoustic Doppler Current Profiler	12
Seafloor Samples	13
Tides	15
Preliminary Results	16
Summerside, PEI	16
Miramichi, NB	21
CTD and dissolved O ₂ measurements	26
Access to Data and Samples	29
Acknowledgements	29
References	29
Appendices	31
Appendix I. Survey particulars	31
Appendix II - Survey personnel	31
Appendix III - Summary of activities (all times in GMT)	32
Day 295 – Wednesday 22 October 2003 – Mobilization	32
Day 296 – Thursday 23 October 2003 – Standby	32
Day 297 – Friday 24 October 2002 – Depart Halifax	32
Day 298 – Saturday 25 October 2003 – En route to Miramichi	32
Day 299 – Sunday 26 October 2003 – Summerside, PEI	32
Day 300 – Monday 27 October 2003 – Charlottetown, PEI	32
Day 301 – Tuesday 28 October 2003 – Charlottetown, PEI	33
Day 302 – Wednesday 29 October 2003 – Summerside, PEI	33
Day 303 – Thursday 30 October 2003 – Summerside, PEI	33
Day 304 – Friday 31 October 2003 – Summerside, PEI	33
Day 305 – Saturday 1 November 2003 – Summerside, PEI	33
Day 306 – Sunday 2 November 2003 – Summerside, PEI	33
Day 307 – Monday 3 November 2003 – Summerside, PEI	34
Day 308 – Tuesday 4 November 2003 – Summerside, PEI	34
Day 309 – Wednesday 5 November 2003 – BIO	34
Day 310 – Thursday 6 November 2003 – BIO	34
Day 321 – Monday 17 November 2003 – BIO to Summerside	34
Day 322 – Tuesday 18 November 2003 – Summerside	34
Day 329 – Monday 24 November 2003 – BIO to Miramichi	35
Day 330 – Tuesday 25 November 2003 – Miramichi	35
Day 331 – Wednesday 26 November 2003 – Miramichi	35

Day 332 – Thursday 27 November 2003 – Miramichi and return to BIO	35
Appendix IV Start and end times of data collection on CCGS <i>Matthew</i>	36
Appendix V Start and end times of graphic records	36
Appendix VI Start and end times of digital tapes	36
Appendix VII Miramichi sample locations and descriptions	37
Eckman grabs	37
Benthos corer	37
Appendix VIII Summerside samples	38
Appendix IX Grab sample photographs – Miramich - November 2003	39
Appendix X Navigation configuration for Matthew 2003069	41
Plotting Room Layout	41
Bridge Connections	42
Main Lab Connections	43

Background

Canada's ports and harbours require routine dredging to maintain operational viability and allow passage of deep-draft vessels. Dredge spoils from these operations are often placed in offshore disposal sites. Monitoring of these disposal sites is required to understand the long term fate of the dredged materials.

The Geological Survey of Canada (GSC), a part of Natural Resources Canada (NRCan) have initiated a project "Assessing Marine Environmental Quality in Coastal Waters of Eastern Canada", that is designed to assess the effects of human activities in marine environments. The project will provide decision makers with geoscience information to resolve user conflicts and balance competing demands for seafloor use with conservation. One of the project priorities is to assess the impact of marine disposal of dredge spoil. Conceptual models will be developed for the behaviour of material in disposal sites under various marine environments, ranging from quite sheltered areas to exposed sites with high tidal and current stress. The project focuses on sites with differing degrees of human impact, management, and user conflict. The project will provide outputs, consisting of maps conforming to new marine-mapping standards and protocols, databases in high-priority areas, conceptual models and reports. The primary outcome of this project will be that ocean-management decisions made by stakeholders will be based on sound scientific information collected by NRCan.

Environment Canada (EC) is mandated with the responsibility to administrate the Disposal at Sea Regulation under Part 7 of the Canadian Environmental Protection Act (CEPA). CEPA requires the Minister of Environment to monitor disposal sites.

NRCan and EC formed a joint project study to study the effects of offshore disposal of dredged material with the intention that collaborative efforts will contribute to, and accelerate, the objectives of both departments.

During 2003, several sites were studied as case studies of the effects of disposal activities in unique environments: a sheltered coastal environment in Summerside, PEI; a tidal estuary in Miramichi, NB; a partially protected site in Yarmouth, NS; and a high energy site in Saint John, NB. The result of the monitoring will be used to compare and contrast the impact of disposal activities in these sites.

Survey Matthew 2003069, conducted from 22 October to 7 November 2003 was scheduled to collect data at the disposal sites in Miramichi, NB and Summerside, PEI. The shipping lane in Summerside, Prince Edward Island, was dredged in 1998 to provide a safe channel for vessels entering and leaving Summerside. The dredged material was placed west of the channel, in Bedeque Bay, in about 2-5 metres of water. A major dredging project was undertaken in 1981-83 in the Miramichi River, New Brunswick, when 6,160,000 metric tonnes of material was dredged from the shipping channel. Much of this material was placed in a disposal site within the Miramichi estuary in 3-5 metres water depth (Site B). Other material was placed in the Miramichi River near Douglstown (Site A), and outside the barrier island in deeper water.

Due to weather conditions at the time of the survey, which prevented work being performed in the Miramichi, the schedule was modified to concentrate on the site at Summerside PEI. Sidescan sonar and sub-bottom profiler data were collected from the CCGS *Matthew* (Fig. 1a). Multibeam bathymetry data were collected over the disposal site with a Simrad EM3000 system, mounted in the survey launch *Plover* (Fig. 1b). Further offshore data were collected with an EM1002 system installed on the

CCGS *Matthew*. These data were used to provide information on the character and distribution of seafloor sediments, and the geological and oceanographic processes that have affected the seafloor over offshore marine disposal sites that received material from dredging the shipping channel and turning basin in Summerside.

After the Matthew 2003069 survey, sediment samples were collected in Summerside PEI. In November 2003, sediment samples, Acoustic Doppler Current Profiler (ADCP), CTD, and dissolved oxygen measurements were collected in the Miramichi estuary, by Tim Milligan of the Department of Fisheries and Oceans using a launch (Figure 1c). These results are included in this report.

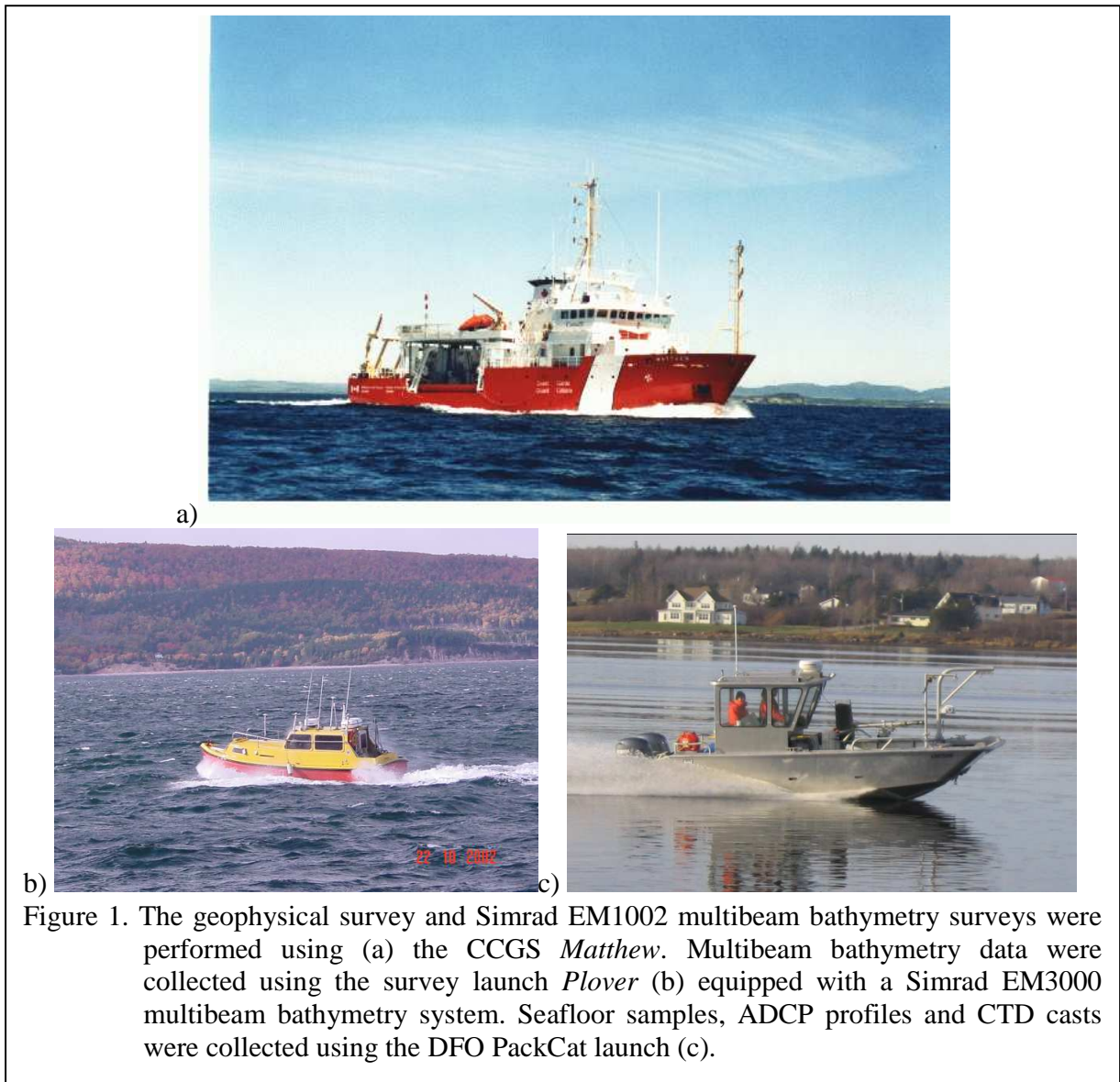

Figure 1. The geophysical survey and Simrad EM1002 multibeam bathymetry surveys were performed using (a) the CCGS *Matthew*. Multibeam bathymetry data were collected using the survey launch *Plover* (b) equipped with a Simrad EM3000 multibeam bathymetry system. Seafloor samples, ADCP profiles and CTD casts were collected using the DFO PackCat launch (c).

Geophysical equipment used during the survey consisted of a Simrad MS992 dual frequency (120 and 330 kHz) sidescan sonar system, and an IKB Seistec sub-bottom profiler. Sediment samples were collected with a Eckman grab sampler and a small gravity corer, and bottom photographs were taken along transects through the survey area. A track plot showing areas where data were collected is shown in Figure 2.

Survey Overview

During the mobilization of the survey, and during equipment calibration procedures on the first morning of the survey, a crew of six personnel from the Canadian Broadcasting Corporation show *The Nature of Things* filmed the deployment and operation of assorted pieces of geophysical and multibeam bathymetry survey equipment. Interviews were recorded on the vessel with GSC employee Steve Blasco (a recent recipient of the Order of Canada) and Mike Lamplugh of CHS. Footage from the interviews and equipment shots will be incorporated into a promotional video for an upcoming documentary series on *The Nature of Things*. In particular, a documentary will be prepared on the use of multibeam bathymetry for studies of the sea floor in Halifax Harbour and lake bottom in Tobemory Park in Ontario.

Prior to 2003, the CCGS *Matthew* utilized a Simrad EM100 system, installed in the early 1990's, for multibeam bathymetry measurements. A state-of-the-art Simrad EM1002 multibeam bathymetry system was installed on the CCGS *Matthew* early in 2003. Personnel from the GSC had not had an opportunity to work with the EM1002 system prior to cruise *Matthew* 2003069. Mike Lamplugh and Chris LeBlanc from the Canadian Hydrographic Service agreed to accompany the vessel during the transit from Halifax to the survey area in Miramichi Bay and familiarize GSC personnel with the assorted hardware and software used for the collection and processing of multibeam bathymetry data with the EM1002 system. Aluizo Maciel de Oliveira Junior from the Brazilian Hydrographic Service also accompanied the vessel to observe some of the techniques utilized by the CHS for data collection. Procedures for taking, editing and downloading the velocity profile of the water column were demonstrated. A patch test required for the detection of systematic errors in the multibeam bathymetry system was performed in Bedford Basin. A guided tour of the hardware associated with the EM1002 system, included details about the operation and calibration of the ram used to deploy the multibeam bathymetry transducer below the ship's hull. Operations of the various software programs was demonstrated and GSC personnel collected data on a series of long lines during the transit. The data were then cleaned to integrate tidal offsets and detect spurious navigation and bathymetry data using the HIPS cleaning and processing software developed by Caris of Fredericton NB. The final activity was to calibrate the outer beams of the EM1002 system. Lines were run at right angles to allow comparison of nadir beams from one traverse with outer beams from orthogonal traverse. A factor was calculated in an iterative fashion, to correct for errors detected in the different traverses. During this procedure, a problem was encountered with the pitch calibration on the EM1002 transducer ram. A temporary solution was applied to correct the problem.

And, then there was the weather! The original scheduled departure date was delayed for two days due to high winds, and equipment problems. Upon arrival at Summerside PEI, gale force winds were forecast for the next 2 to 3 days, forcing the vessel to take refuge. Unfortunately, there was no dock space available in Summerside, requiring the vessel to transit back to Charlottetown to dock at the Coast Guard Base. Three days later, the *Matthew* departed Charlottetown for the transit to Summerside. Upon arrival at Summerside, the wind had increased again and the vessel docked. The survey launch *Plover* was able to collect some data over the disposal site in less-than-ideal conditions. Two days later, the *Matthew* departed Summerside, and collected a series of multibeam bathymetry lines for the remainder of the day and throughout the night. The *Plover* collected data over the disposal site from noon to midnight. The following morning winds increased again to gale force. Gale force winds forecast for the following day failed to fully materialize, and the launch *Plover* collected data over the disposal site. Finally a day with light winds occurred and multibeam bathymetry data were collected over an older disposal site, while sub-bottom profiler, sidescan sonar and multibeam bathymetry data were collected further offshore. The gale to storm force winds forecast for the next three days, extended beyond the remaining time left on site, ending the survey. The vessel remained in

Summerside for most of the next day and departed for Halifax during the evening of 5 November 2003, after the winds had decreased.

After the multibeam bathymetry survey, seafloor samples were collected in Summerside PEI by Tim Milligan of the Habitat Ecology group of the Department of Fisheries and Oceans, at the Bedford Institute of Oceanography. Grab samples, small cores, Acoustic Doppler Current Profiler (ADCP) data and CTD, and dissolved oxygen casts were obtained over Dumpsite A in Miramichi River and Dumpsite B in Miramichi Inner Bay.

Data Acquisition and Processing

The following geophysical and sampling equipment was used during survey Matthew 2003069:

- Simrad MS992 sidescan sonar system in a neutrally-buoyant tow configuration
- IKB Seistec[®] high resolution sub-bottom profiler
- AGCDIG 4-channel digital geophysical data acquisition system
- GSCDIG 4-channel digital geophysical data acquisition system
- Regulus survey navigation package with input from differential GPS
- Simrad EM3000 multibeam bathymetry system
- Linux workstations running GRASS with GSCA extensions
- Caris HIPS multibeam bathymetry data cleaning software running on Windows NT
- RDI Intrumentst Workhorse Acoustic Doppler Current Profiler
- Eckman Grab sampler
- Benthos gravity corer

Sidescan Sonar

High-resolution, acoustic images of the seabed were produced with a Simrad MS992 dual frequency (120 and 330 kHz) sidescan sonar system mounted in a neutrally-buoyant towbody and deployed 13 metres behind a dead weight depressor (a 120 kg iron blister weight on a swivel) as shown in Figure 2. The towfish was deployed about 50 metres behind the vessel. This configuration was chosen to reduce artifacts seen on the sidescan sonar records due to vessel-induced heave, and thereby improve resolution. The sidescan sonar system was capable of resolving objects as small as about 0.15 m. An ORE TrackPoint II acoustic position system was used to position the towfish. A hardcopy graphic record of the 330 kHz portion of the sidescan sonar data was produced on an Alden 9315CTP thermal recorder.

Sidescan sonar data from survey Matthew 2003069 (both 120 and 330 kHz) were collected at 100 metre range using an AGCDIG digitizer with version 2.3 software. A sample interval of 80 microseconds was used. 3400 samples per ping were collected at 200 metre range and 1700 samples at the nominal 100 metre range setting. Digital gain settings for the sidescan sonar system and digitizers were logged on field sheets. During the survey, data were imported into a Linux workstation at a resolution of 0.35 metres (across track). The seafloor was detected and slant range and beam corrections were applied to the raw data to remove geometric distortions present in sidescan sonar data. The data were integrated with navigation and imported into the GRASS GIS system at 0.5 metre resolution for data near the disposal site and 1.0 metre resolution for regional data. The sidescan sonar data from adjacent survey lines were integrated to produce a sidescan sonar mosaic. A variable layback, based on towfish positions from the TrackPoint II positioning system, was applied to the sidescan sonar data.

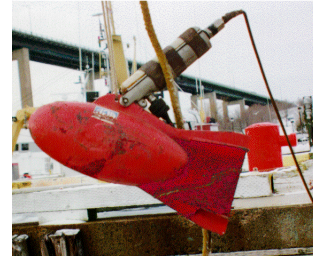
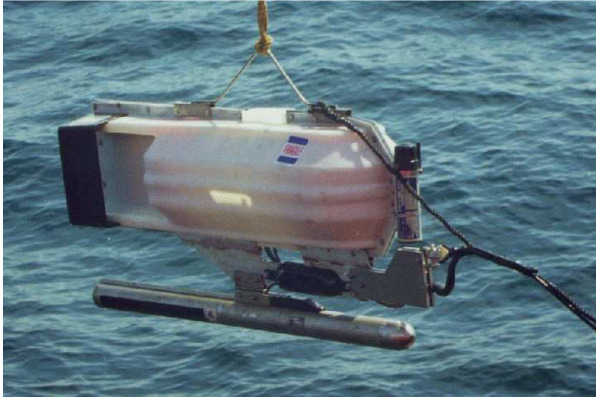

Figure 2. Neutrally buoyant sidescan sonar towfish (shown on the left) and deadweight depressor used by GSCA. The towfish was towed about 13 metres behind the deadweight depressor. The TrackPoint II beacon is visible on the front of the towfish, but not used during this survey.

IKB Technologies Seistec Sub-bottom profiler

An IKB Technologies Seistec high-resolution, sub-bottom profiler system was used to map the thickness and structure of materials on the sea floor and provide information on the genesis of the sediments. The system uses an electrodynamic (boomer) source to produce a repeatable impulse-like output providing a vertical resolution of 0.25 metre or better. The Seistec system was equipped with an internal line-and-cone array and an external streamer. The boomer and line-and-cone array are contained in a small catamaran as shown in Figure 3. The external streamer was attached to the front of the catamaran, so that the lead-in section of the streamer was positioned under the boomer and line-and-cone array with the receiving elements trailing behind the catamaran. The catamaran was deployed by crane on the starboard side of the vessel and towed on the port side at the surface. The system was fired 2 times per second, or faster, and graphic records were displayed on a thermal graphic recorder. The power supply to the boomer was operated at a nominal setting of 175 Joules. Graphic records were printed on an EPC9800 recorder set for 125 millisecond scans in two channel mode. Data were sampled at a 38 microsecond interval for 124 milliseconds to provide 3845 samples per channel. Bandpass filtered signals were recorded. External streamer data were filtered at 1000 to 7000 hertz.

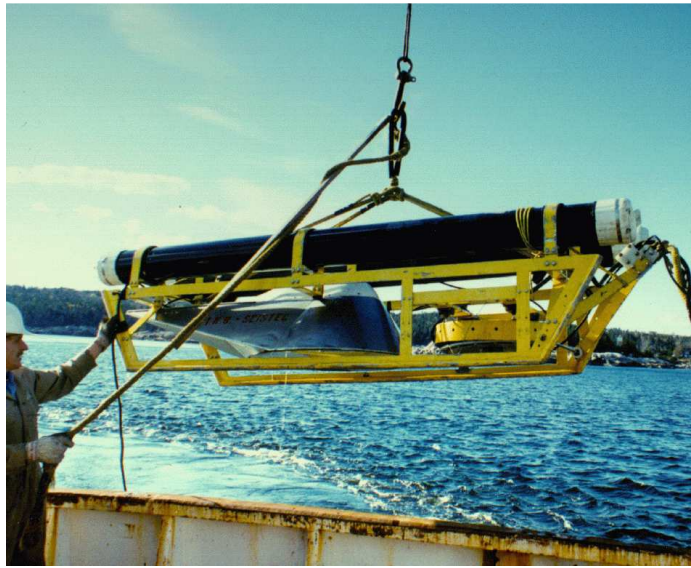

Figure 3. Seistec sub-bottom profiler showing the catamaran used to tow the boomer and line-and-cone array at the surface. Power and signals are contained in the tow cable bundle on the front of the catamaran.

Digital Data Acquisition

The sidescan sonar and sub-bottom profiler data were digitized and logged on an AGCDIG digital data recorder, developed by the Geological Survey of Canada (Atlantic), running version 2.3 software. The clock in the AGCDIG was synchronized to the GPS time signal. No gains or corrections were applied to the raw logged data during digitization. Channel configurations for the logged data were:

Sidescan sonar - 80 microseconds sample interval

Channel	Use
0	120 kHz port
1	120 kHz starboard
2	330 kHz port
3	330 kHz starboard

Sub-bottom profiler – IKB Seistec - 38 microseconds sample interval

Channel	Use
0	STB Seistec line cone receiver
1	STB GF10/15P streamer hydrophone

Data were also recorded on the new GscDig, a seismic and sidescan sonar digitizing system which will replace the ageing AgcDig systems with a modern computer and A/D board. The system is highly oriented to networking and modular components, and mainly consists of a digitizer/logger module and a simple real time or file display. The digitizer program is called GDAim (Analog Input Module) and runs on a special GscDig computer containing high speed sigma delta digitizer boards. In addition to the A/D, the computers have DVD Burners and 180 GByte hard disk drives. The computers are connected to the ship's ethernet and in a workgroup called GSCA and use DHCP for IP numbers and share the GscDig directories on the C: drive.

Navigation

Navigation was provided by a Global Positioning System utilizing differential corrections broadcast by the Canadian Coast Guard. Accuracy of the navigation was about 4 m.

Tracks and survey lines were run with the *Regulus II* navigation software (build 24799 - 2003.8.5) by ICAN Limited, Mount Pearl, NF. The primary navigation computer, in the navigation room on the bridge deck, received differential GPS signals from the bridge receiver (*Magnavox*). See Appendix VII for diagrams of the equipment installation. The primary navigation computer was also configured with line feeds on Com 2 to input from the *TSS POS/MV320* integrated inertial positioning and attitude sensor system, however the navigation feed from the bridge was generally used. The GPS feed included position, course over ground and speed over ground. The navigation data along with the heading from the *Anschutz Kiel* gyrocompass and depth below keel from the *ELAC LAZ 4400* echosounder were combined through a *Baytec* multiplexer which fed the combined data to a line splitter for distribution over the ship's RS-232 data distribution network. The video output from the main navigation computer was split by a *VideoView* signal splitter in the navigation room and fed to the bridge. The bridge personnel were able to monitor the navigation for geophysical line running from, either the central telegraph on the bridge for running lines, or from the starboard wing telegraph for sampling stations. Unfortunately, the two bridge monitors could not be viewed simultaneously due to the signal cable configuration.

An additional *Regulus* computer was placed in the after-lab on the main deck, where the geophysical equipment was operated, to provide a display of the vessel position overlain on charts and multibeam bathymetry images. This computer received the same positioning data as the computer in the navigation room. Data from this computer was also forwarded to the *Seistec* AGCDIGS computer, the *Simrad MS992* sidescan AGCDIGS computer, the sidescan, the record annotator and the digital underwater camera.

A third navigation computer was placed in the navigation room, as a spare, and used to modify waypoints or sampling station markers while conducting surveys. These data would then be transferred to the main navigation computer without interruption on the bridge display. Unfortunately, this computer eventually became inoperable for navigation when the *Regulus II* software refused to load.

Multibeam Bathymetry

Multibeam bathymetric data were collected using a *Simrad EM3000* multibeam bathymetry system mounted in the hydrographic survey launch *Plover* (Figure 1b). The *EM3000* system uses 300kHz transducer with 127 beams with a beamwidth of $1.5^\circ \times 1.5^\circ$. The system provides a depth resolution of 1 cm with an accuracy of 5 cm RMS. Each beam insonifies an area of approximately 1.35 m^2 at 50 metres water depth. A *Simrad EM1002* system was used on the *CCGS Matthew* using a 95 kHz transducer with 121 beams with a beamwidth of 2° . The system provides coverage to a depth of 1000 metres, and across-track coverage of up to 1200 metres in deep water.

Each vessel used an Applied Analytics Corporation POS-MV 320 attitude sensing system with integrated differential GPS navigation system to determine the position and attitude. The systems integrate data from an inertial measurement unit and differential GPS signals. A positional accuracy 0.5 to 4 metres can be obtained using the phase differential of the GPS carrier frequency when using DGPS, and of 0.02-0.10 metres when using an RTK source. This survey was performed using DGPS data for an accuracy of 0.5 to 4 metres. A heading aiding accuracy of $0.1^\circ - 0.5^\circ$ can be obtained from the raw GPS data. A Kalman filter is used to improve the heading estimate to $0.05^\circ - 0.1^\circ$. Vessel

attitude is measured using an inertial measurement unit to provide an accuracy of 0.0003° for pitch, roll and heading. More information on this system can be found at www.applanix.com.

Survey lines were run at a variety of spacing throughout the survey area to provide 200 percent coverage of the seafloor. Data were processed using version 5.0 of the HIPS data cleaning program (CARIS by Universal Systems Limited, Fredericton, NB) on a Windows NT workstation to remove spurious soundings and navigation data and to correct for tidal variations. Data were also imported into a Linux based workstation and processed using the MBTools software developed by the Lamont-Doherty Institute. The processed data were imported into the GRASS GIS system where shaded-colour relief images were generated and overlaid on bathymetry maps of the area.

During the survey, tidal amplitude corrections were made using predicted tides generated using the program Tides and Currents by Nobeltec. Amplitudes were measured by a temporary gauge installed in Cheticamp NS.

Multibeam Backscatter

The strength of an echo from the seafloor is known as the acoustic backscatter intensity. Acoustic backscatter intensity values are controlled by the physical properties of the seafloor sediments such as the velocity of sound, the density and roughness of the sediment. Backscatter generally increases as the sediments on the seafloor become denser and less porous, and increase in grain size. Acoustic backscatter intensity measurements extracted from the Simrad EM1002 and EM3000 data were used to map the character and distribution of sediments.

Acoustic Doppler Current Profiler

Seafloor sediments are remobilized by currents induced by tides, river flow, wind and waves. Data were collected at various stages of the tide, using an RD Instruments 1200kHz Sentinel Acoustic Doppler Current Profiler (ADCP), to measure current velocities in the water column and near the seafloor and provide information on the potential for sediment remobilization. Velocities were calculated for 75 bins of 0.25m size, to provide information on the flow velocities in the study area. A blanking interval of 0.25m exists, where no data were obtained near the seafloor adjacent to the transducer face. The system used a beam angle of 20 degrees. Data were acquired and displayed using the RDI WinRiver software. Diagrams displaying an ensemble average of 5 pings were generated and are shown later in this report. More details on the system can be obtained at <http://www.rdinstruments.com/>.

Seafloor Samples

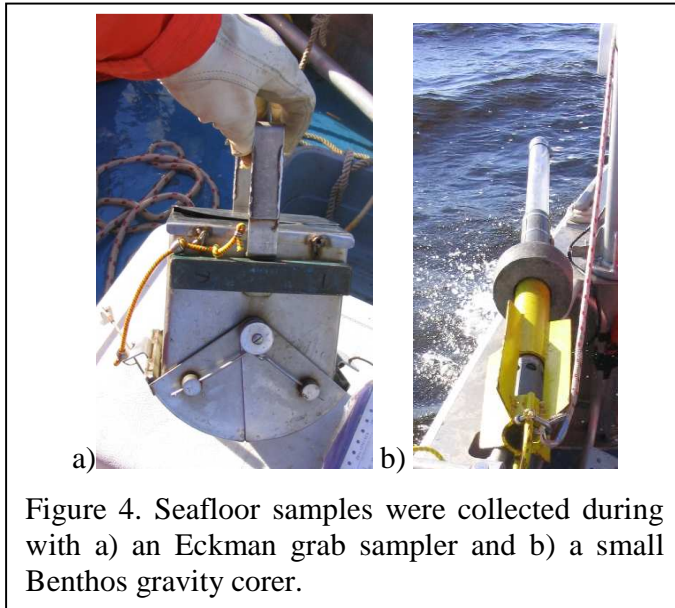

An Eckman grab sampler was used to collect sediment samples in Summerside PEI and Miramichi NB (Figure 4a). Cores were taken in selected areas with a small Benthos gravity corer (Figure 4b). The sample locations are shown in Figure 5 and are provided in Appendix VII. Digital images were taken of most of the grabs and are incorporated as 'hotlinks' in an ArcView GIS data base to provide geographically referenced access to the images. Low-resolution copies of all available grab sample images are presented in this report in Appendix V. A copy of a CDROM with the images was archived at the Geological Survey of Canada offices in Dartmouth, NS. Grain size distribution and chemical analyses will be performed on the samples.

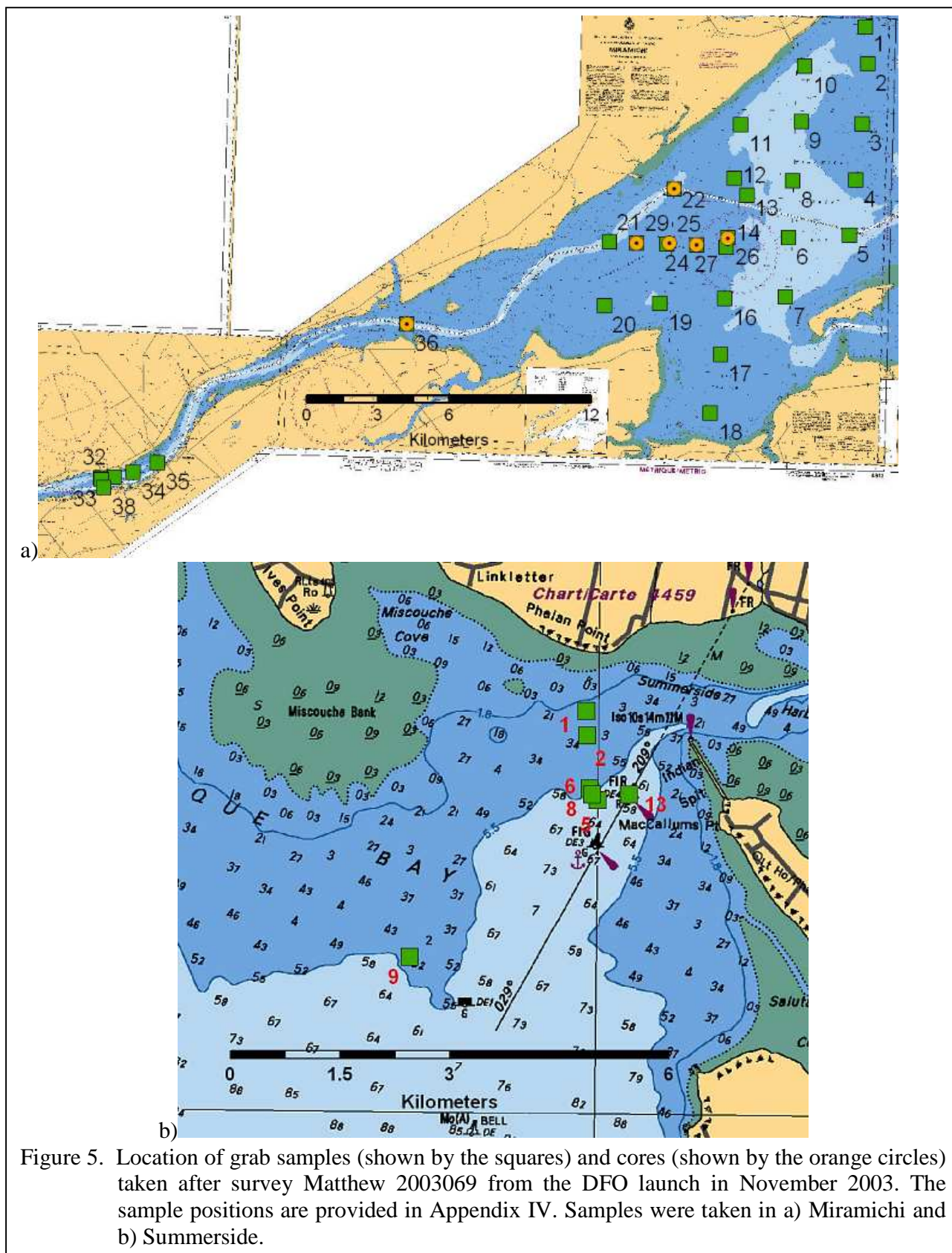

Tides

During the survey, predicted tides for the survey area in Summerside PEI were calculated using the program Tides and Currents Pro by Nobeltec (Figure 6a). In addition a Vemco TDR was deployed at the Summerside Marine Terminal to provide a local (but unreferenced) level. A tidal range of about 2 metres was predicted. Predicted tides were calculated for Chatham NB for use during ADCP profiles and sampling operations (Figure 6b).

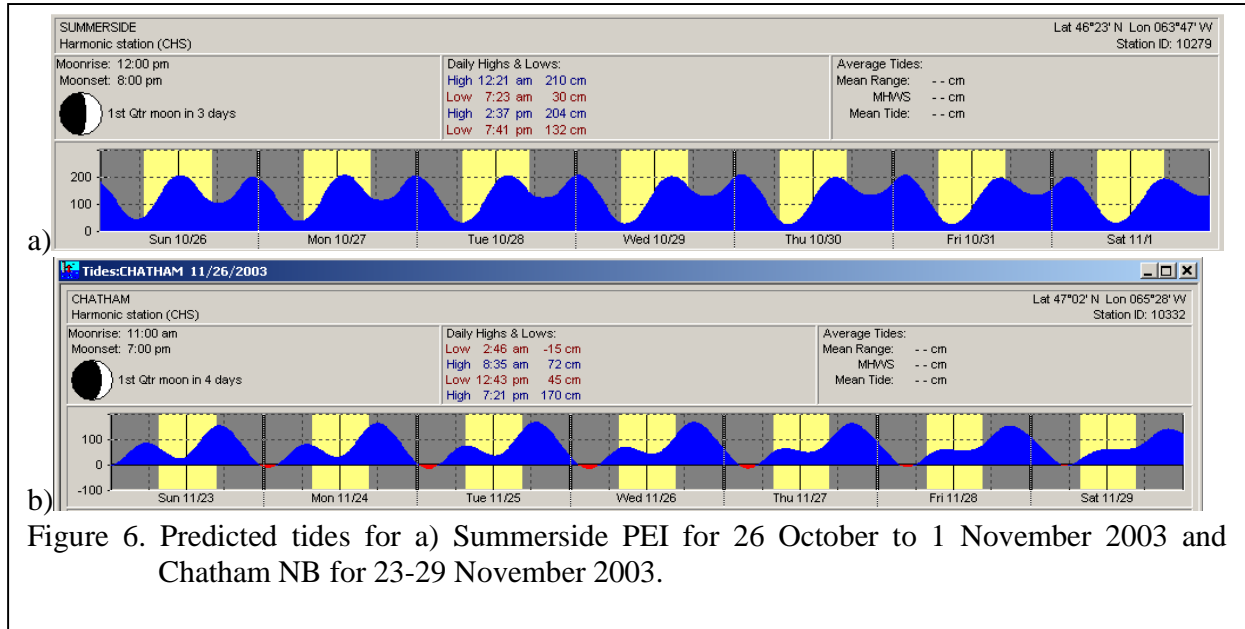

Figure 6. Predicted tides for a) Summerside PEI for 26 October to 1 November 2003 and Chatham NB for 23-29 November 2003.

Preliminary Results

Summerside, PEI

Multibeam bathymetry and backscatter data were collected over disposal sites in Bedeque Bay, adjacent to the shipping channel in Summerside, and in a 15 km long zone offshore, during cruise Matthew 2003069, as shown in Figure 7. The nearshore surveys were performed using a Simrad EM3000 system on the launch *Plover*. The offshore survey was performed using a Simrad EM1002 system mounted in the CCGS *Matthew*. Sidescan sonar and sub-bottom profiler data were collected along the red line shown on the offshore survey.

The offshore survey shows evidence of an old river drainage system identified by Kranck (1971) who mapped a series of ancient river channels and a lake, of unknown age, and argued that some of the principal valleys were deepened in places, perhaps by ice. The rivers formed a rough surface with numerous valleys and ridges. During the Pleistocene, glaciers were interpreted to have eroded the previously formed drainage system and deposited a widespread glacial till. Kranck (1972) proposed that the post-glacial history of Northumberland Strait depended on a complex interplay between glacial rebound and submergence. After falling for a few thousand years sea-level began rising after 9000 BP and the Strait became completely flooded approximately 5,000 years ago (Shaw et al., 2002).

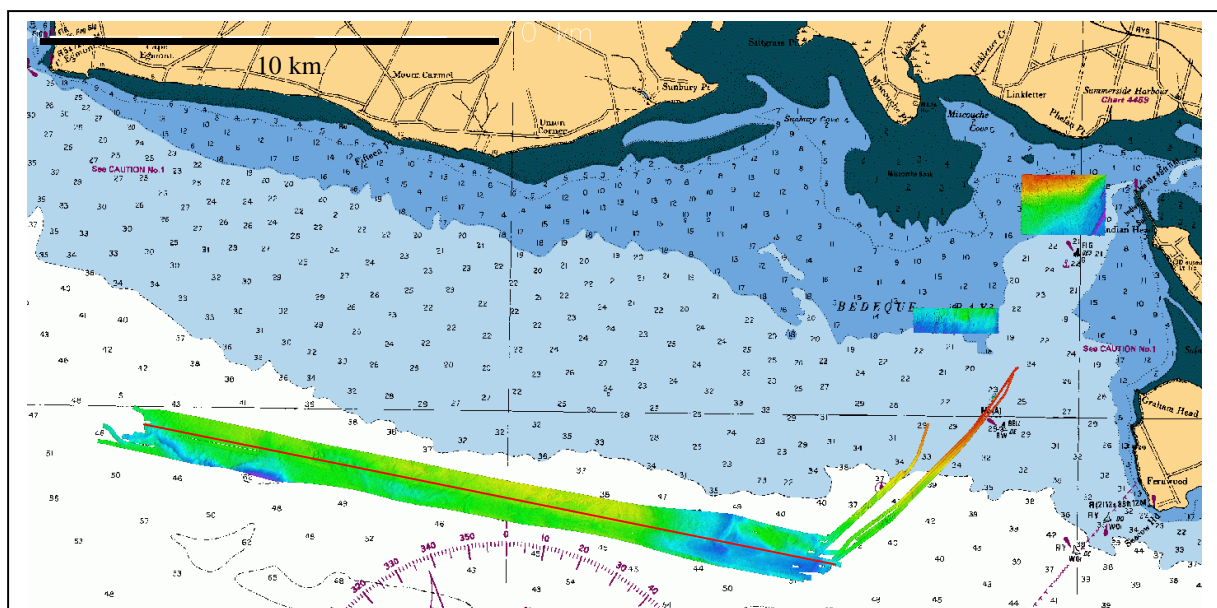

Figure 7. Location of multibeam bathymetry data collected off Summerside PEI during Matthew 2003069. The nearshore surveys were performed using a Simrad EM3000 system. The offshore survey was performed using a Simrad EM1002 system. Sidescan sonar and sub-bottom profiler data were collected along the red line shown on the offshore survey.

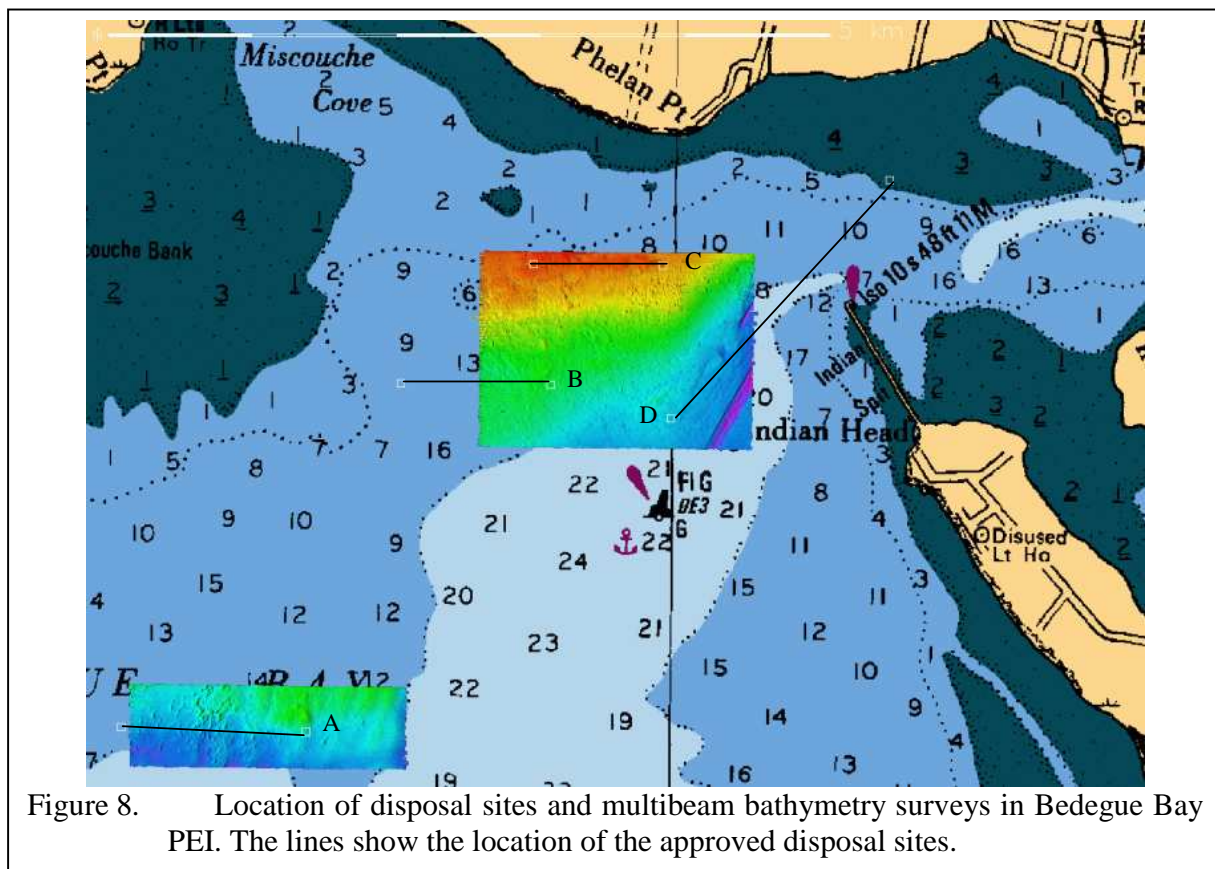
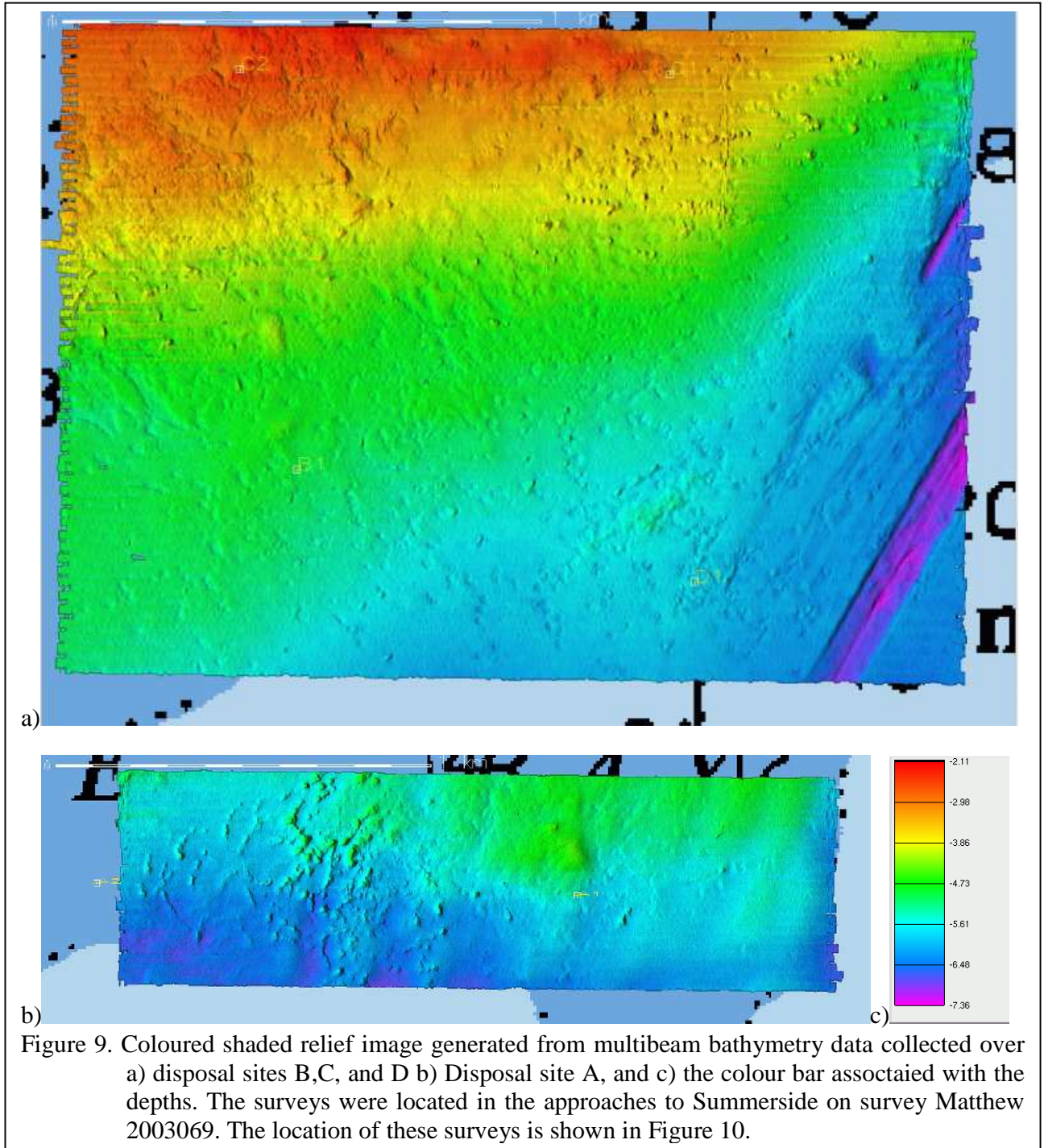

Figure 8. Location of disposal sites and multibeam bathymetry surveys in Bedegue Bay PEI. The lines show the location of the approved disposal sites.

Shaw et al. (1997) reported on the results of a multibeam bathymetry survey performed in 1996 by the Canadian Hydrographic Service, which confirmed the presence of the ancient river system, and interpreted that the valleys generally deepened towards the southeast, suggesting drainage in that direction. They confirmed that the valleys had been deepened in places, so that the paleo-landscape included a series of lake basins connected by rivers. The valleys of the river system appeared to be incised into glacial deposits. The 'fresh' appearance of the tributary valleys feeding into the principal valleys, led Shaw et al. (1997) to suggest that the tributary channels were postglacial in age.

About 80,500 m³ of material has been dredged from the shipping channel and turning basin in Summerside and placed in approved offshore disposal sites. Shaded colour-relief images were generated from the Simrad EM3000 multibeam bathymetry data collected over the disposal sites. Figure 8. Sites A and B have not received any material since 1992. Site C received about 49,000 m³ of dredged material, place by a scow, between 1992 and 1995. Site D received about 31,500 m³ of dredged material, place by a suction dredge, in 1995.

The image in Figure 9a shows details of the survey over sites B, C, and D. A large cluster of dredge spoils in about 5 metres water depth in the northeast portion of the image, near the location of site C. Some of the dredge spoils are aligned in straight or arcuate lines, indicating disposal from a moving vessel. The dredged channel is quite evident in the southeast portion of the image and aligns with the position of the channel on the hydrographic chart. An additional section of the seafloor appears to have been excavated about 200 metres north of the channel. A series of linear features are present just north of the channel and could be related to the dredging process where a suction cutter dredge was used, or may be related to propeller wash from vessel maneuvering outside the channel.



The image in Figure 9b shows details of the survey over site A, where a large concentration of dredge spoils are evident in about 7 metres water depth in southwest portion of the image. Since this disposal site was last used prior to 1992, only a coarse grained material would have remained as discrete piles of sediments in the strong currents and wave conditions that are encountered at this site.

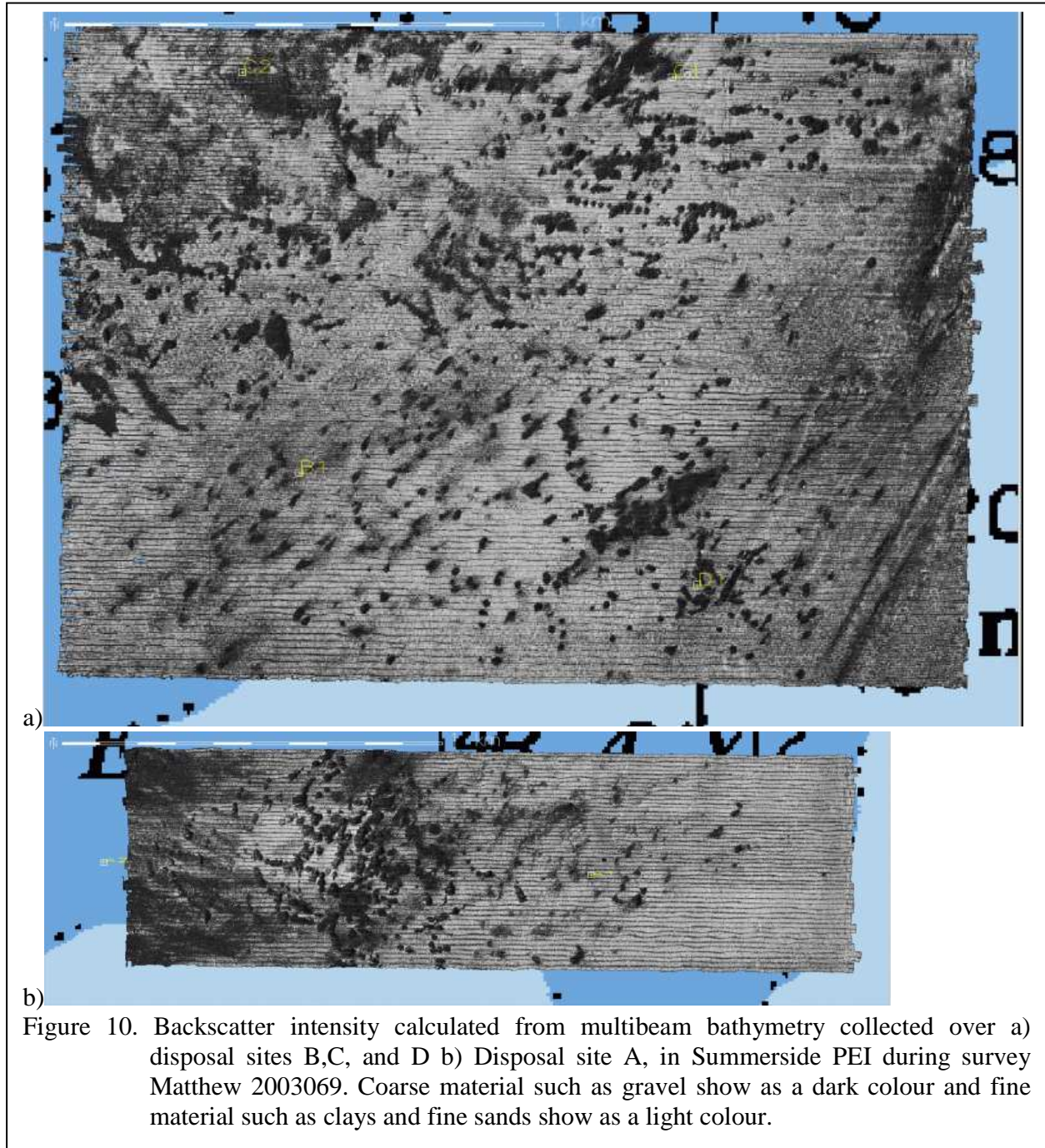

The multibeam bathymetry data were also processed to extract backscatter intensity values and these values used to generate a mosaic (shown in Figure 10). The dredge spoils are visible throughout the images as the discrete small dark areas. While many of the dark areas are associated with bathymetric highs, others are associated with small depressions in the seafloor.

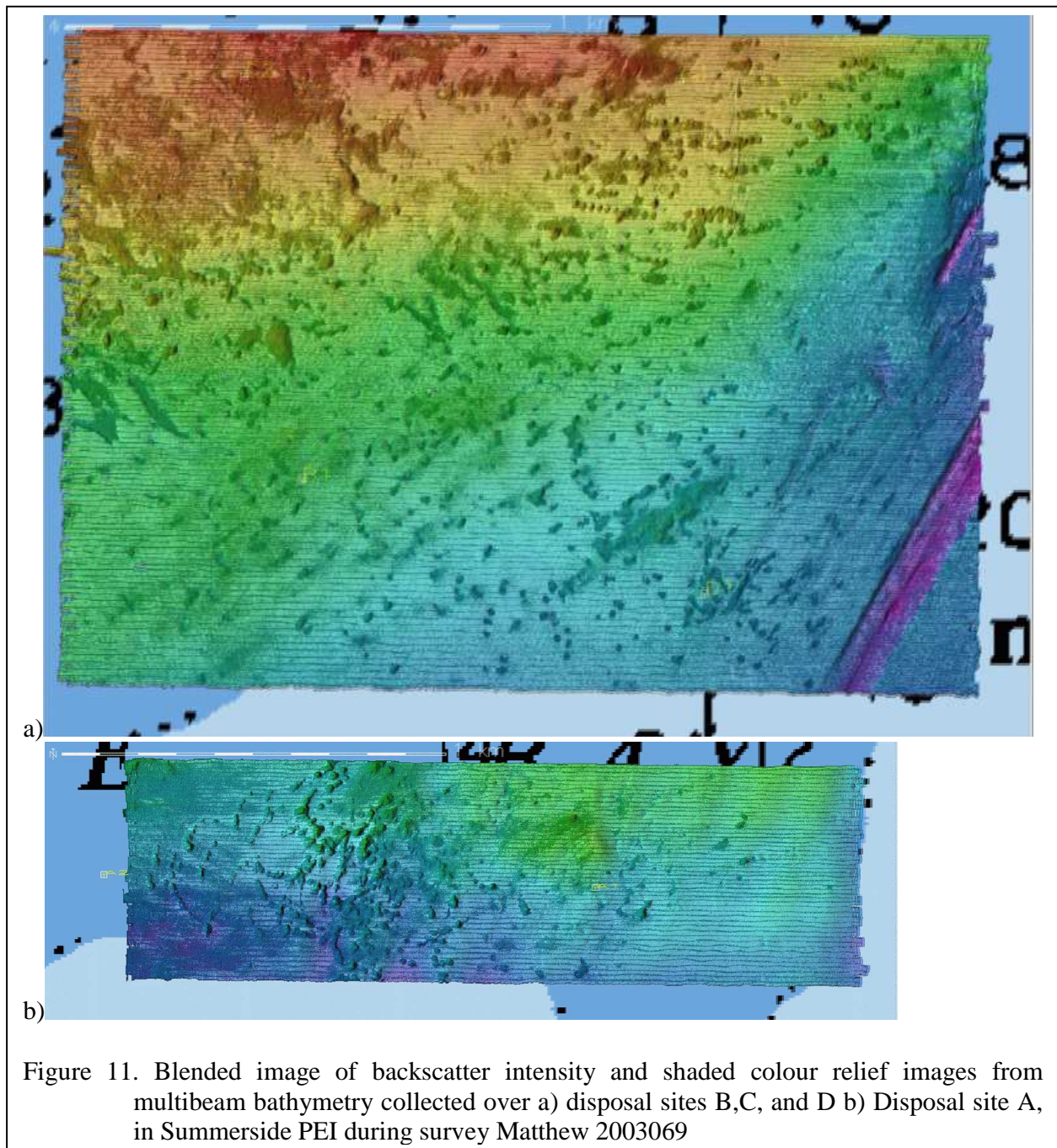

As an experiment, the images of the colour shaded relief (Figure 9) and backscatter intensity (Figure 10) were combined, to study the relationship between the high acoustic backscatter intensity (dark areas) and bathymetry. The image in Figure 11 shows an image generated by using 50% weighting for colour shaded relief and backscatter intensity. The combined image confirms that the discrete dark areas are associated with both bathymetric highs and depressions. It appears that, where dredge spoils were dumped on a soft seafloor, a small depression may have been excavated.

Miramichi, NB

Seafloor sediments are remobilized by currents induced by tides, river flow, wind and waves. Acoustic Doppler Current Profiler (ADCP) data were collected at various stages of the tide to measure current velocities in the water column and near the seafloor and provide information on the potential for sediment remobilization. Data were collected on 3 traverses in the Miramichi River and Inner Bay as shown in Figure 12. Each profile was run for two stages of the tide. The resulting profiles are plotted in Figures 13 to 15 with hot colours (reds) indicating flow down stream (out of the page in the diagrams), and cold colours (blues) indicating flow up stream (into of the page in the diagrams). The tide plot for each profile is provided, indicating the timing of the ADCP profiles. Note that the tides are asymmetric in the survey area, with the lowest amplitude changes occurring during the daylight hours during the survey. Higher velocities would have been encountered in the other phases of the tide. Tidal predictions were available for several locations within Miramichi Inner Bay. The ADCP profiles are presented with predictions from the closest location.

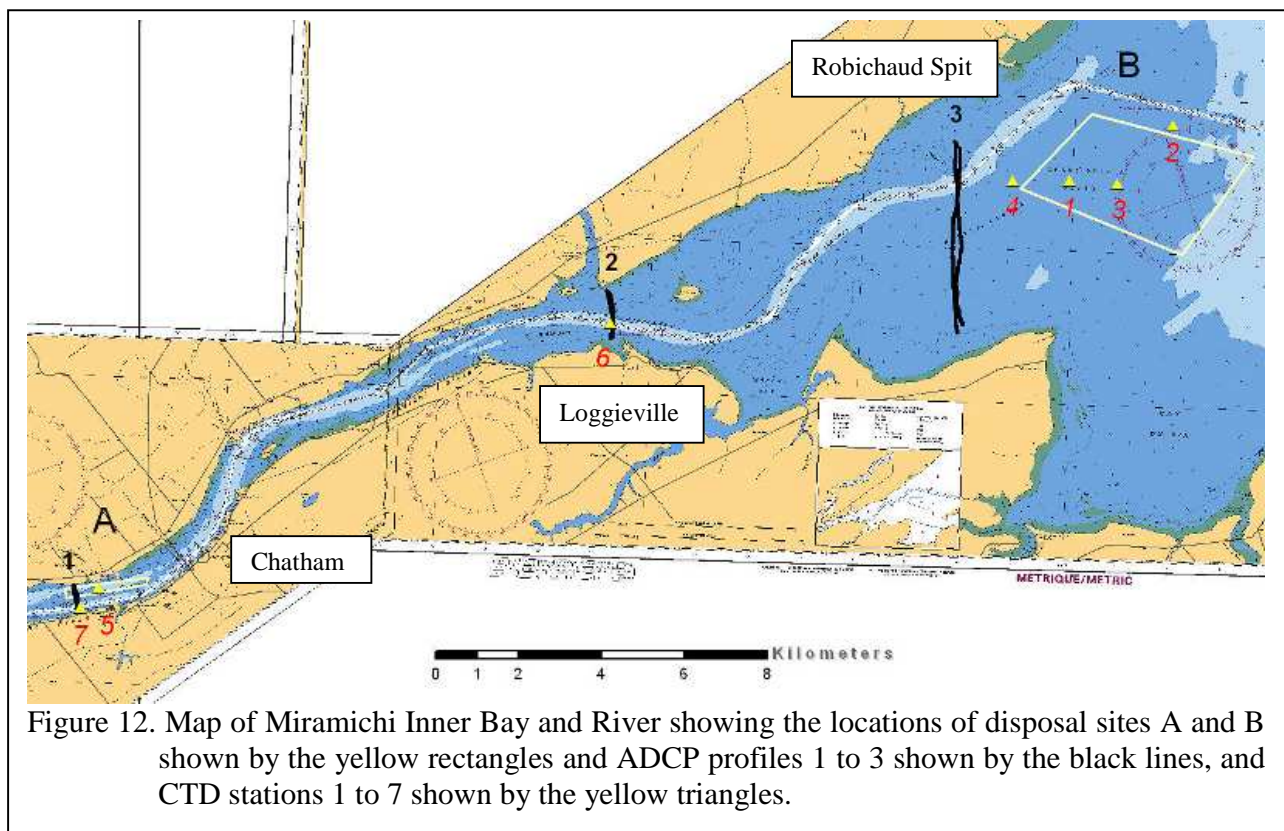

Figure 12. Map of Miramichi Inner Bay and River showing the locations of disposal sites A and B shown by the yellow rectangles and ADCP profiles 1 to 3 shown by the black lines, and CTD stations 1 to 7 shown by the yellow triangles.

Profile 1 was taken over the upstream portion of Disposal Site A, near Douglastown. Predicted tides for Chatham are used for a comparison of the data. On the falling tide, as shown in Figure 13a, downstream velocities of about 0.5 m/s can be observed on the surface of the water column, with an upstream component of about 0.13 m/s observed over the deepest part of the channel at 5.5 metres depth. Just after the tide started to rise (Figure 13b), downstream velocities of 0.7 m/s were observed at the surface, and the upstream component was found moved deeper in the channel. Note that these profiles were collected using predicted tides only, and that the differences were quite small between the phases of the tides.

The transects in Profile 2, located near the entrance of the Bartibog River, just downstream from Loggieville, are shown in Figure 13. Note that the transects were taken quite close in time. The first profile (Figure 14a) was run at slack tide, and most of the flow is seen to be down stream. As the tide starts to rise there was an increase in the depth of the surface layer flowing downstream at about 0.7

m/s. A small zone of upstream flow can be seen, south of the main channel. Predicted tides from Loggieville are used for a comparison of the data.

The transects in profile 3, located near Robichaud Spit, are shown in Figure 15. Predicted tides from Robichaud Spit are used for a comparison of the data. The first profile (Figure 15a) was run on the ebb tide, and most of the flow in the top 1-2 metres is seen to be down stream with velocities as high as 0.6 m/s. Below 2 metres, most of the flow is upstream, with a velocity of about 0.2 m/s. The second transect was taken at near the maximum flood tide (Figure 15b). The surface layer was flowing downstream at about 0.2 m/s. In the shipping channel, upstream velocities of about 0.7 m/s were encountered.

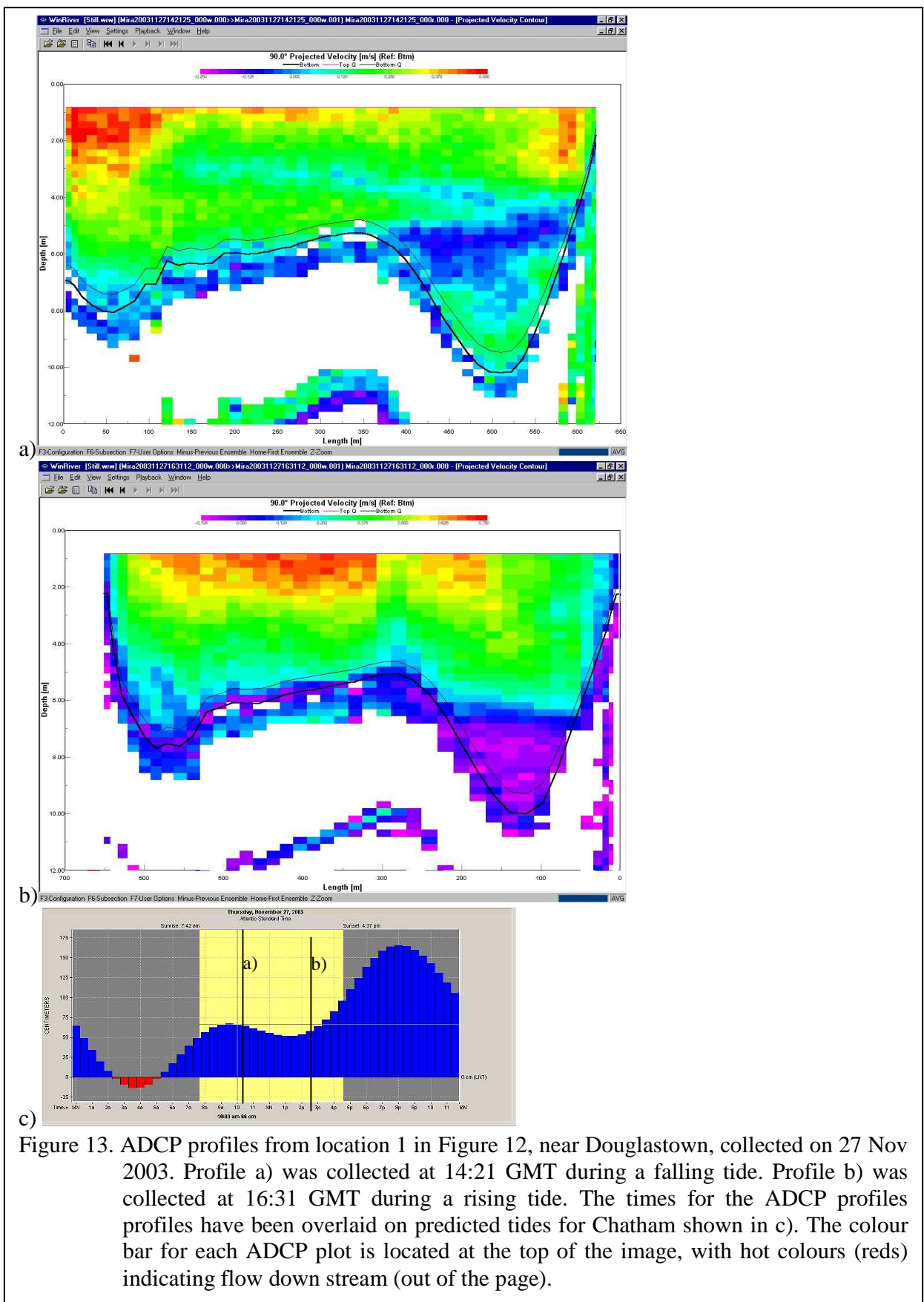
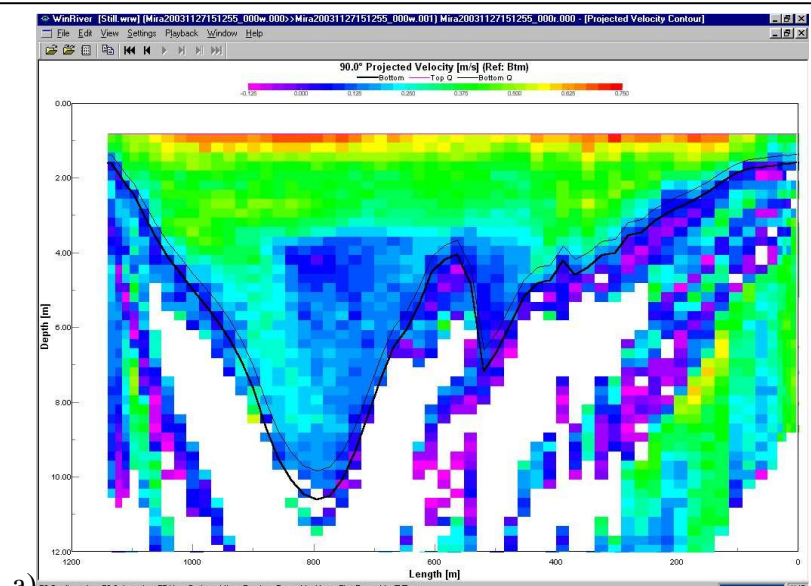
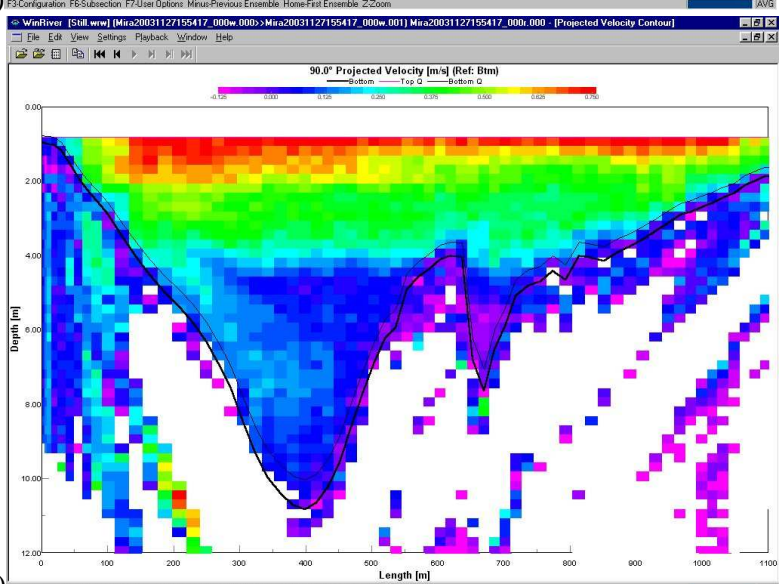

Figure 13. ADCP profiles from location 1 in Figure 12, near Douglastown, collected on 27 Nov 2003. Profile a) was collected at 14:21 GMT during a falling tide. Profile b) was collected at 16:31 GMT during a rising tide. The times for the ADCP profiles have been overlaid on predicted tides for Chatham shown in c). The colour bar for each ADCP plot is located at the top of the image, with hot colours (reds) indicating flow down stream (out of the page).



a)



b)

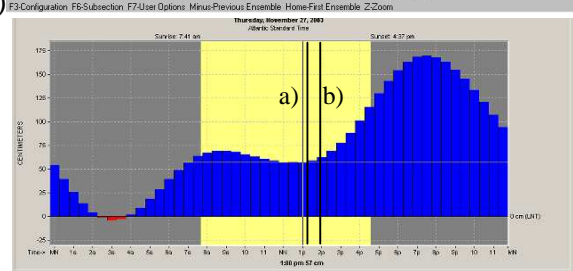

c)

Figure 14. ADCP profiles from location 2 in Figure 12 collected on 27 Nov 2003. Profile a) was collected at 15:12 GMT during a falling tide. Profile b) was collected at 15:54 GMT during a rising tide. The times for the ADCP profiles have been overlaid on the predicted tides for Loggieville shown in c). The colour bar for each ADCP plot is located at the top of the image, with hot colours (reds) indicating flow down stream (out of the page).

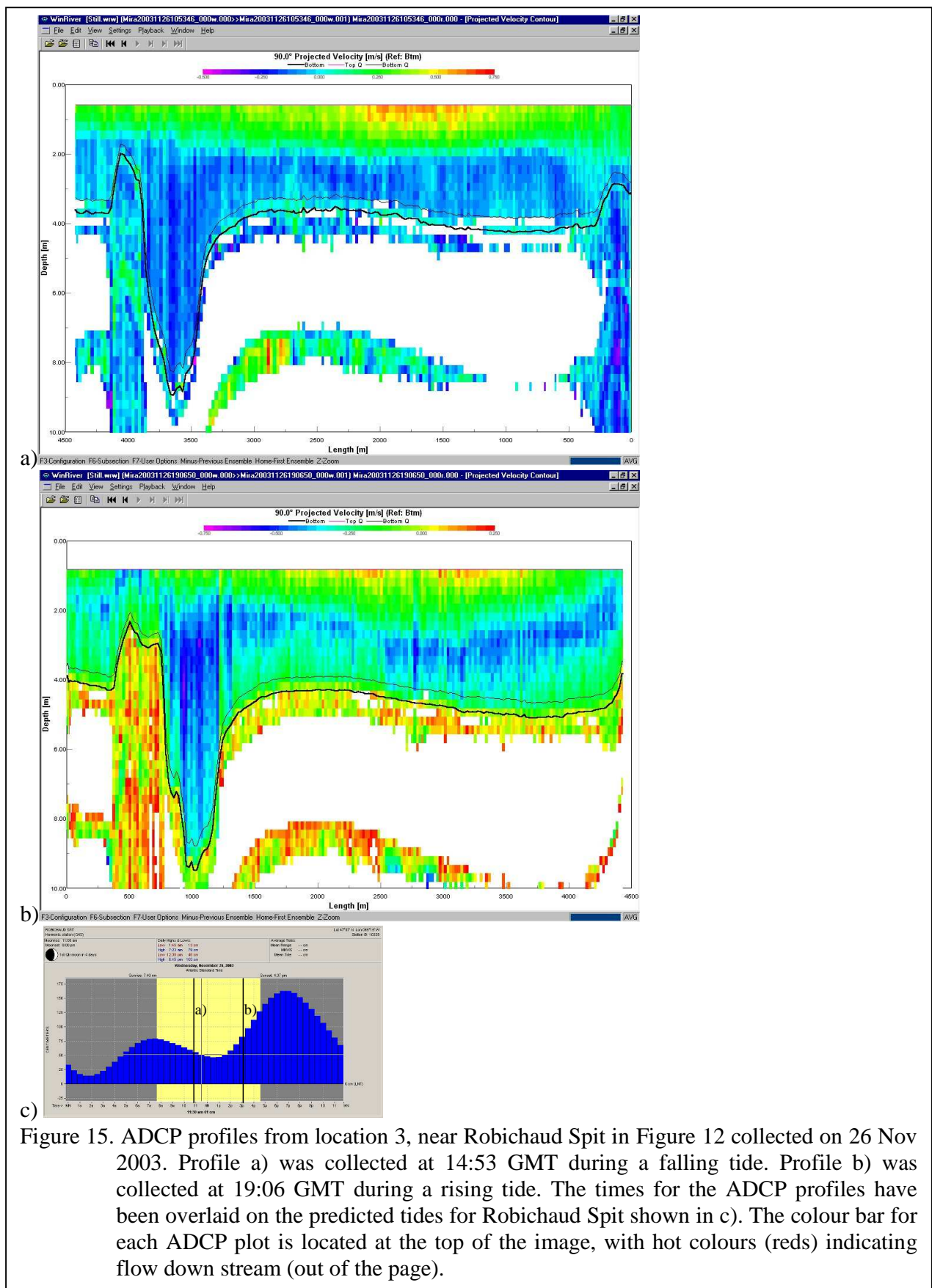
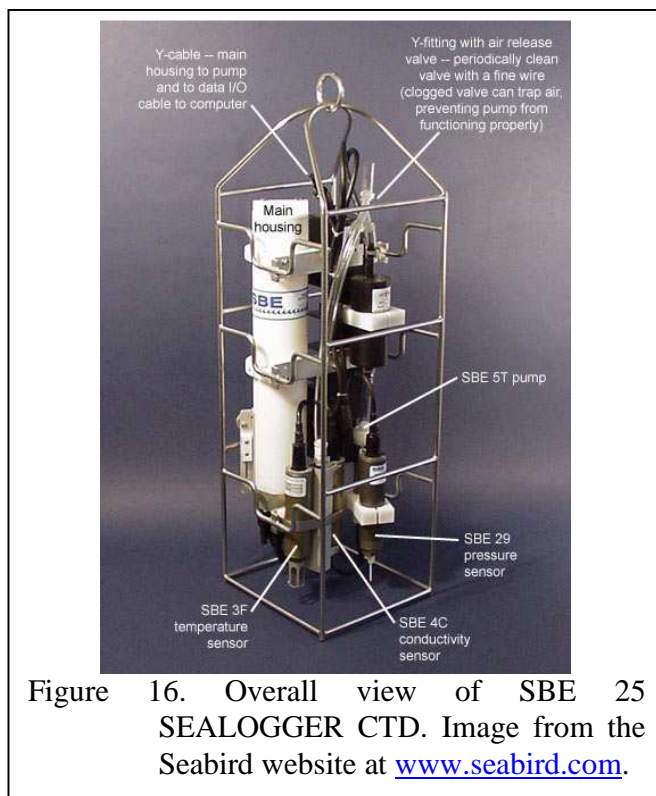

Figure 15. ADCP profiles from location 3, near Robichaud Spit in Figure 12 collected on 26 Nov 2003. Profile a) was collected at 14:53 GMT during a falling tide. Profile b) was collected at 19:06 GMT during a rising tide. The times for the ADCP profiles have been overlaid on the predicted tides for Robichaud Spit shown in c). The colour bar for each ADCP plot is located at the top of the image, with hot colours (reds) indicating flow down stream (out of the page).

CTD and dissolved O₂ measurements



Nine profiles were acquired using a Seabird 25 CTD to determine the characteristics of the water column in the study area to provide insight into the mixing of the fresh water from the river and brackish water from the inner bay. The package was fitted with the following sensors: SBE 3F temperature sensor, SBE 4C conductivity sensor, SBE 29 pressure sensor, SBE 5T pump chlorophyll fluorescence, photosynthetic active radiation (PAR), dissolved oxygen and optical backscatter (OBS). An image of the standard configuration of the SBE 25 is shown in Figure 16.

The instrument were recorded internally at 8 Hz as the system was lowered and retrieved by hand. The data were subsequently downloaded and processed. Sample temperature, salinity, and turbidity data (derived from the OBS) are presented in Figures 17-19 which show the changes in the salinity and suspended particulate matter distributions along the estuary. The locations of the profiles are given in Table 1. The locations of profiles plotted in Figures 17-19 are are shown in Figure 12.

Station	Cast	Date	Time (UTC)	Latitude			Longitude			Depth (m)
1	1	11/26/2003	17:20	47	6.925	N	65	12.081	W	4.3
1	2	11/26/2003	17:27	47	6.925	N	65	12.081	W	4.3
2	1	11/26/2003	17:53	47	7.680	N	65	10.134	W	5.6
3	1	11/26/2003	18:17	47	6.903	N	65	11.172	W	5.2
4	1	11/26/2003	18:53	47	6.900	N	65	13.168	W	5.2
5	1	11/27/2003	14:01	47	1.244	N	65	30.351	W	6.7
6	1	11/27/2003	15:32	47	4.896	N	65	20.760	W	10.7
7	1	11/27/2003	16:42	47	0.980	N	65	30.684	W	10.3
7	2	11/27/2003	16:53	47	0.977	N	65	30.681	W	10.4

Table 1 Location of CTD casts in Miramichi Inner Bay during survey Matthew 2003069.

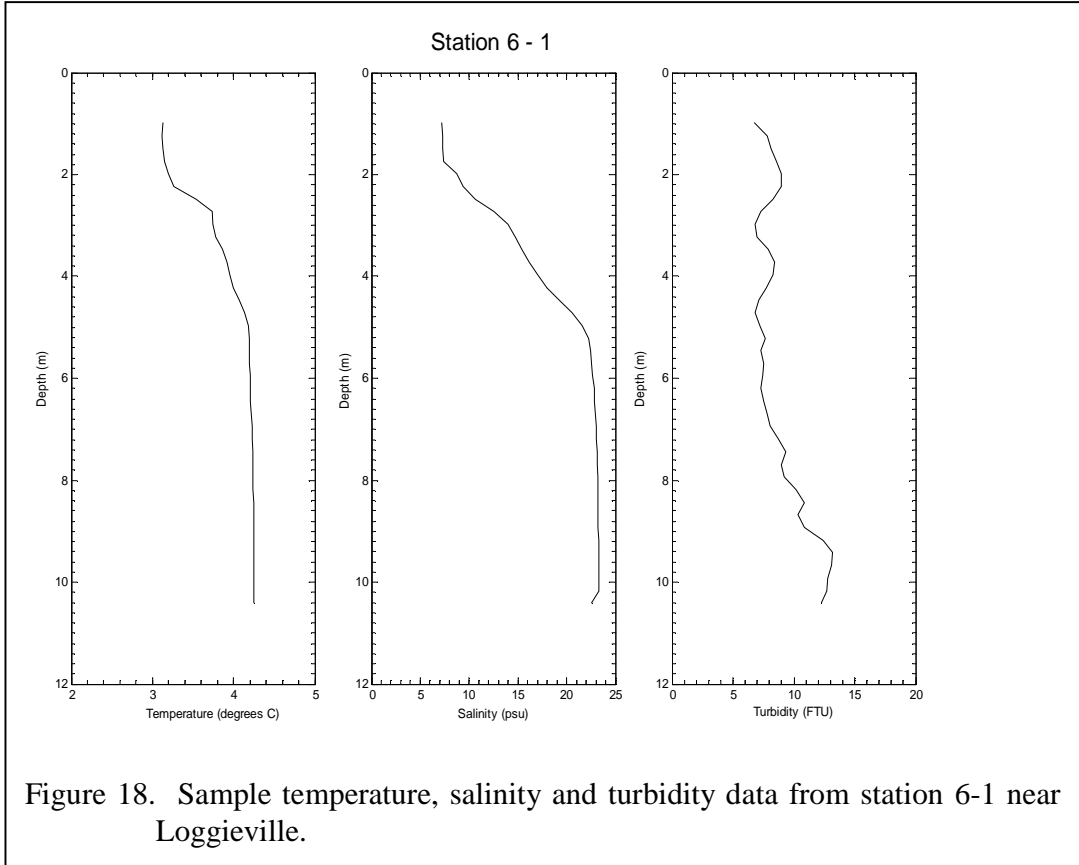
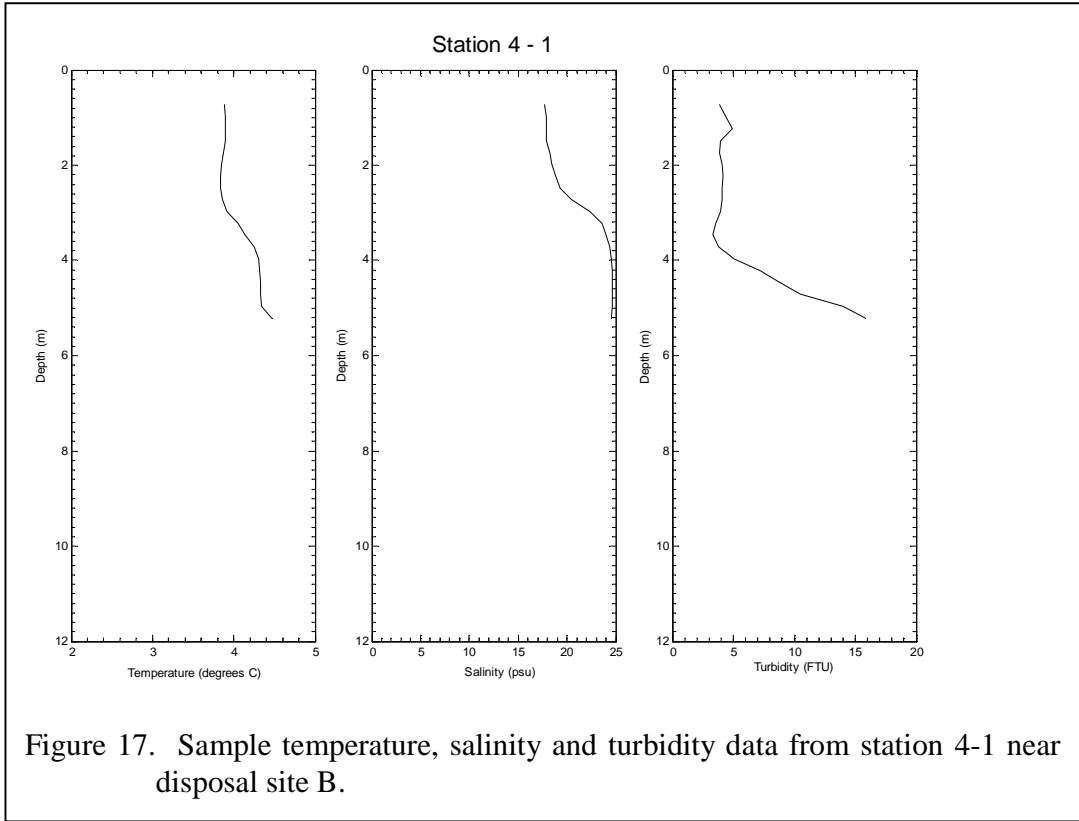

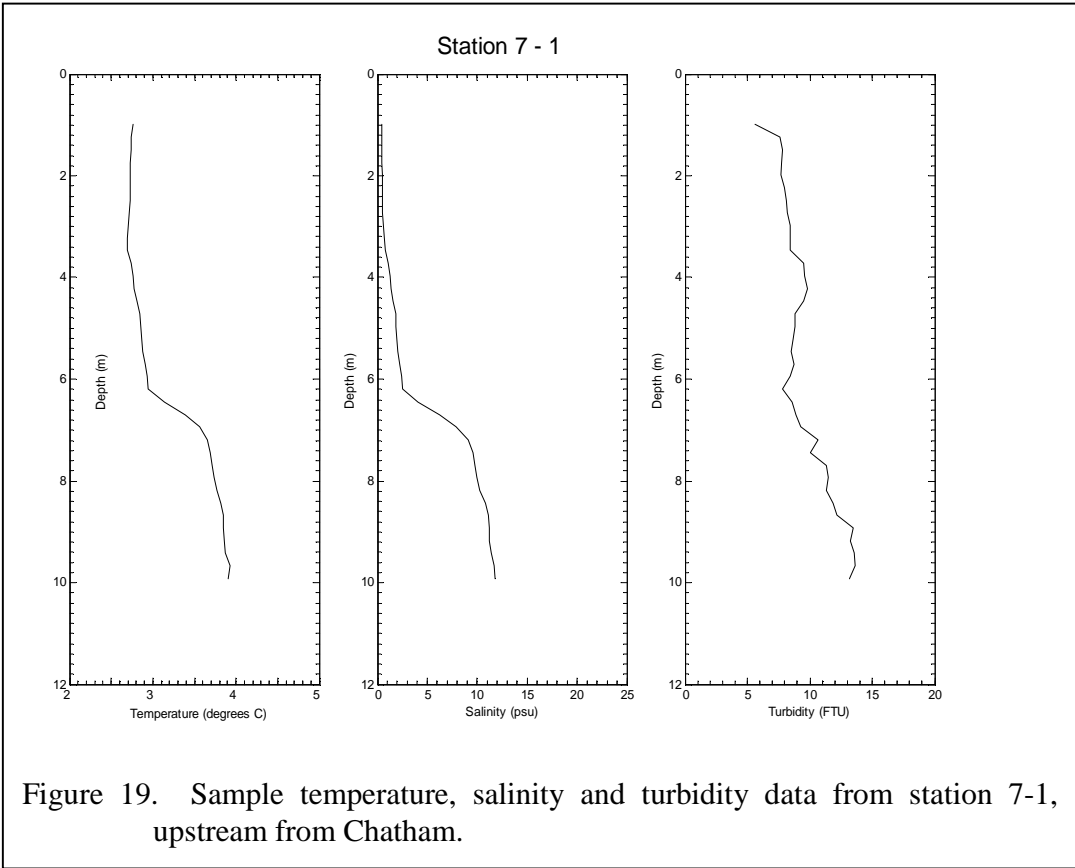

Access to Data and Samples

The sidescan sonar, sub-bottom profiler, multibeam bathymetry, photographs, and grab samples collected during this survey are archived at the Geological Survey of Canada - Atlantic, in Dartmouth Nova Scotia. For access to the geophysical data and samples contact the senior scientist for the survey, Russell Parrott (902-426-7059) or Susan Merchant of the GSCA. Digitally processed sidescan sonar mosaics, ExaByte tapes containing the sidescan sonar data in SEG-Y format, CD-ROMs containing the sidescan sonar and sub-bottom profiler data in SEG-Y format, and ExaBytes tapes of the raw data are available for viewing.

Acknowledgements

We would like to thank the officers and crew onboard the CCGS *Matthew* for their assistance in the various surveys. Angus Robertson provided the diagrams and a detailed description of the navigation configuration. Brent Law assisted with sample collection on the DFO PackCat launch in Summerside, PEI and Miramichi, NB. The draft report was reviewed by John Shaw.

References

- Applanix Corporation, 85 Leek Crescent, Richmond Hill, Ontario, CANADA L4B 3B3. Phone 905-709-4600. E-mail Info@applanix.com Website <http://www.applanix.com>
- CARIS HIPS hydrographic data cleaning software, CARIS, 264 Rookwood Avenue Fredericton, New Brunswick, CANADA, E3B 2M2. <http://www.caris.com>
- Kranck, K. 1971. Surficial geology of Northumberland Strait: Marine Science Paper 5, Geological Survey of Canada Paper 71-53, 9 pp.
- Kranck, K. 1972. Geomorphological developments and post-Pleistocene sea level changes, Northumberland Strait, Maritime Provinces. Canadian Journal of Earth Sciences, **9**, pp 835-844
- Nautical Software Inc, Tides and Currents 4.2, 14657 SW Teal Blvd, Suite 132, Beaverton, Oregon, USA 97007 Copyright 1994-1998. Nautical Software Inc., <http://www.tides.com>
- Olex Display Software by Olex AS Pirsenteret N-7462 Trondheim Norway http://www.olex.no/index_e_NY.html
- Parrott, D.R. 2002. Cruise Matthew 2001065 Geophysical Surveys and Sampling Operations in the Northumberland Strait and Saint John NB 23 October – 7 November 2001. GSC Open File Report In press. November 2002.
- RD Instruments 9855 Businesspark Avenue San Diego, CA 92131 USA Tel: (858) 693-1178 Fax: (858) 695-1459 <http://www.rdinstruments.com/>
- Shaw, J., Courtney, R.C., Fader, G.B., Parrott, D.R., Taylor, R.B., and Hughes-Clarke, J.E. 1997: Application of multibeam bathymetry to sea-level studies in Atlantic Canada. Proceedings, Canadian Coastal Conference 1997, Guelph, Ont. p. 350-359.
- Shaw, J., Gareau, P., and Courtney, R.C., 2002. Paleogeography of Atlantic Canada 13-0 kyr. Quaternary Science Reviews, v. 21, no. 16-17, p. 1861-1878.

Sea-Bird Electronics, Inc., 1808 136th Place NE Bellevue, Washington, USA 98005 Tel: 425-643-9866 Fax: 425-643-9954 Email: seabird@seabird.com Web: <http://www.seabird.com>
www.seabird.com.

Appendices

Appendix I. Survey particulars

Name of Vessel:	CCGS Matthew
Vessel captain:	Paul Bragg
Dates of Survey:	24 October – 5 November 2003
Area of Operation:	Summerside, PEI
Senior Scientist:	Russell Parrott, GSCA

Appendix II - Survey personnel

Geological Survey of Canada Atlantic

Russell Parrott	Senior Scientist
Anthony Atkinson	Electronics Technologist
Fred Jodrey	Sampling/photography
Darrel Beaver	Multibeam bathymetry data collection/multibeam data processing
Angus Robertson	Navigation and EM1002
Lori Cook	Geophysical watchkeeping and record keeping

Canadian Hydrographic Service

Michael Lamplugh	EM1002 training
Chris LeBlanc	Caris Hips training

Brasilian Hydrographic Service

Aluizo Maciel de Oliveira Junior	Visiting hydrographer
----------------------------------	-----------------------

Others

Walli Rainey	Geophysical watchkeeping and record keeping
Eric Patton	Navigation and EM1002

Sampling Program - Summerside

Tim Milligan	DFO Scientist
Brent Law	DFO Scientist

Sampling Program - Miramichi

Tim Milligan	DFO Scientist
Gary Bugden	DFO Scientist
Brent Law	DFO Scientist
Russell Parrott	NRCan Scientist

Appendix III - Summary of activities (all times in GMT)

Day 295 – Wednesday 22 October 2003 – Mobilization

All GSC gear is mobilized on CCGS *Matthew* at BIO to be ready to sail at 12:00. Problems with a ship's generator and a bad weather forecast delays scheduled departure until Friday 24 October.

Day 296 – Thursday 23 October 2003 – Standby

GSC and ship personnel assist CGC film crew from "The Nature of Things" to obtain video footage of activities related to multibeam bathymetry, geophysical surveying, and underwater video as part of a promotional feature for a new series.

Day 297 – Friday 24 October 2002 – Depart Halifax

- 11:00 GSC and CBC personnel deploy small ROV to provide additional footage for CBC documentary
- 12:00 GSC personnel arrive CCGS *Matthew* (Parrott, Beaver, Atkinson, Robertson and contractor Patton). Mike Lamplugh and Chris LeBlanc from the Canadian Hydrographic Service and Aluizo Maciel de Oliveira Junior from the Brazilian Hydrographic Service accompany the vessel to familiarize GSC personnel with the Simrad EM1002 multibeam bathymetry system installed on the CCGS *Matthew* in early 2003.
- 13:00 Depart BIO to perform patch test for multibeam bathymetry system. CBC personnel obtain video footage of activities.
- 17:30 CBC personnel depart vessel and return to BIO.
- 18:00 Perform Fire and Boat drill prior to departing Bedford Basin.
- 19:00 Depart Bedford Basin en route to Miramichi NB by way of the Canso Canal.

Day 298 – Saturday 25 October 2003 – En route to Miramichi

- 11:00 GSC personnel continue familiarization with the EM1002 system while en route to Miramichi. Overview of software, computer hardware and EM1002 hardware including operation of ship's ram to deploy transducer. Collect data while in transit to Cobequid Bay.
- 16:00 Patton and Robertson start to process data from patch test in Halifax to become familiar with the cleaning and processing software.
- 17:30 Transit through lock in the Canso Causeway. Encounter 20 knot winds in St. Georges Bay, and check the weather forecast. Strong southwesterly winds predicted for Sunday and Monday in Miramichi area. Decide to transit to Summerside for early Sunday morning and perform multibeam bathymetry survey of disposal site in harbour approaches.
- 22:30 Transit in Northumberland Strait

Day 299 – Sunday 26 October 2003 – Summerside, PEI

- 11:00 Near Summerside PEI. Weather forecast for strong winds later in the day, increasing tomorrow. No dock space available in Summerside due to scheduled arrival of large vessels.
- 12:00 Commence calibration procedure to calibrate the outer beams of the EM1002 system. Lines run at right angles to allow comparison of nadir beams from one traverse with outer beams from orthogonal traverse. Problem encountered with the pitch calibration on the EM1002 transducer ram.
- 14:30 Complete calibration. Set course for Charlottetown to avoid predicted strong winds.
- 20:00 Arrive Charlottetown and secure at Coast Guard Base.

Day 300 – Monday 27 October 2003 – Charlottetown, PEI

Secure at Coast Guard Base Charlottetown due to high winds.

- 13:00 Lamplugh, LeBlanc and de Oliveira depart Matthew for Halifax by rental car.
Continue with cleaning of EM3000 data from Yarmouth.
- 23:45 Rainey, Cook and Jodrey arrive by vehicle from Halifax.

Day 301 – Tuesday 28 October 2003 – Charlottetown, PEI

- Secure at Coast Guard Base Charlottetown due to high winds.
Continue with cleaning of EM3000 data from Yarmouth.
Winds decrease late in the day, but are forecast to increase Wednesday afternoon.

Day 302 – Wednesday 29 October 2003 – Summerside, PEI

- 10:00 Depart Coast Guard Base Charlottetown and transit to Summerside. Jodrey remains on shore to drive GSC vehicle to Summerside.
Continue with cleaning of EM3000 data from Yarmouth.
- 15:00 Secure at Summerside Marine Terminal near Coast Guard Base Summerside due to forecast high winds.
- 17:00 Deploy survey launch *Plover*. Problems encountered with multibeam system. Different components appear not to be communicating properly.
System shutdown and rebooted. Now seems to be working.
- 21:00 *Plover* returns after running a series of lines at the disposal site. Survey conditions less than ideal due to the shallow water and short choppy waves.

Day 303 – Thursday 30 October 2003 – Summerside, PEI

- 10:00 Strong winds from the west. Secure at Summerside due to high winds. Continue with cleaning of EM3000 data from Yarmouth.

Day 304 – Friday 31 October 2003 – Summerside, PEI

- 10:00 Strong winds from the west. Secure at public wharf Summerside Marine Terminal due to high winds.
- 17:00 Winds abate. Deploy launch *Plover* to continue survey over disposal site.
- 18:00 CCGS *Matthew* departs Summerside to commence survey further offshore.
- 19:00 Complete velocity cast. Start running SE-NW line.
- 22:00 Run NW-SE line. Recover launch *Plover* for data download and supper.
- 23:00 Deploy *Plover* to continue survey over disposal site, and surrounding area.
- 23:59 Continue with EM1002 survey off Summerside.

Day 305 – Saturday 1 November 2003 – Summerside, PEI

- 00:01 Continue with EM1002 survey off Summerside. *Plover* running lines over disposal site.
- 04:30 Recover *Plover* from survey. Continue with EM1002 survey off Summerside.
- 11:30 Winds increasing as predicted by forecast.
- 12:30 Secure at Summerside Marine Terminal due to winds, and to exchange Coast Guard personnel.
Continue with cleaning of EM3000 data from Yarmouth and Summerside, and EM1002 data from Summerside. Winds remain high throughout the day.

Day 306 – Sunday 2 November 2003 – Summerside, PEI

- 11:30 Secure at Summerside Marine Terminal due to predicted gale force winds.
- 12:30 Deploy launch *Plover* to continue with survey over disposal site.
Continue with cleaning of EM3000 data from Yarmouth and Summerside, and EM1002 data from Summerside.
Test small ROV – continued problems with water leaks around connectors.

Day 307 – Monday 3 November 2003 – Summerside, PEI

- 11:30 Deploy launch *Plover* to continue with survey over disposal site.
- 12:00 CCGS *Matthew* departs Summerside to commence survey further offshore.
Make arrangements for vehicles from GSCA to arrive at Matthew to transport personnel back to BIO.
- 13:00 Complete velocity cast. Deploy sidescan sonar and Seistec. Start running SE-NW line to abut previous data and provide data for comparison of sidescan sonar vs EM1002 backscatter resolution. Sub-bottom profiler data will be used to determine depth extent of channels etc. identified on multibeam.
Discuss problems with access to CHS computers by GSCA computers with Lamplugh. The easiest solution is to leave a GSC computer attached to the network until the ship returns to Halifax, and the CHS system will be modified to allow access. This is a bit of a nuisance – but acceptable.
- 16:00 Recover sidescan sonar and Seistec. Continue running nw-se lines with EM1002.
- 20:45 End of multibeam bathymetry lines. Recover ram.
Note: The EM1002 had trouble tracking the seafloor just before the end of the line. Comparison with earlier data showed that the system had encountered problems at the same location while leaving the harbour. Something about the water column and seafloor characteristics at this location result in problems for the system.
- 21:15 Secure alongside Summerside Marine Terminal.
- 21:25 Recover launch *Plover*.
- 21:45 Murphy arrives from GSCA with vehicle.
Note strong (gale and storm force) winds forecast for next 3 days with only a short period of light winds.

Day 308 – Tuesday 4 November 2003 – Summerside, PEI

- CCGS *Matthew* secure at public wharf Summerside due to gale force winds. Scheduled to depart later in day when winds subside.
- 13:00 Beaver, Murphy and Atkinson depart CCGS *Matthew* in Summerside to recover tide gauge installed in Chatam for Miramichi survey.
- 17:00 Vehicle driven by Chapman from GSCA arrives at Matthew to transport personnel back to BIO.
- 21:00 CCGS *Matthew* departs Summerside.

Day 309 – Wednesday 5 November 2003 – BIO

GSCA at BIO. Finish unloading vehicles and set up computers back in the office. CCGS *Matthew* en route to BIO.

Day 310 – Thursday 6 November 2003 – BIO

CCGS *Matthew* secure at BIO. Demobilize geophysical gear. Problem with FTP access to CHS computers addressed by Steve Perry (GSC) and Mike Ruxton (CHS). Transfer data from CHS computers to GSC computers.

Day 321 – Monday 17 November 2003 – BIO to Summerside

Milligan and Parrott select sediment sample sites near the Summerside offshore disposal sites. Milligan and Law Depart BIO for Summerside.

Day 322 – Tuesday 18 November 2003 – Summerside

Milligan and Law collect samples near the disposal sites, and return to BIO.

Day 329 – Monday 24 November 2003 – BIO to Miramichi

Milligan, Law, Bugden and Parrott depart BIO and transport DFO PackCat launch to Miramichi, NB.

Day 330 – Tuesday 25 November 2003 – Miramichi

Milligan, Law, Bugden and Parrott collect samples near the Disposal Site B and within Miramichi Inner Bay. The boat is launched and recovered at the boat ramp in Chatham near the old train station – now called Choo-Choo's bar.

Day 331 – Wednesday 26 November 2003 – Miramichi

Milligan, Law, Bugden and Parrott collect samples near Disposal Site B and within Miramichi Inner Bay. ADCP system calibrated and profiles collected in the Inner Bay. CTD and dissolved O₂ measurements taken.

Day 332 – Thursday 27 November 2003 – Miramichi and return to BIO

Milligan, Law, Bugden and Parrott collect samples and ADCP profiles near Disposal Site A and within Miramichi Inner Bay. CTD and dissolved O₂ measurements taken. The launch is loaded on the trailer and transported back to BIO.

Appendix VII Miramichi sample locations and descriptions

Eckman grabs

Stn No	Station Type	Refer No.	Day/Time	Latitude	Longitude	Depth	Comments
1	Eckman Grab	212665	3291520	47 11.9670	65 05.7430	4.2	Thin brown veneer over black oxidized mud
2	Eckman Grab	212666	3291534	47 11.1173	65 05.6230	4.0	Brown silty sand with shell hash
3	Eckman Grab	212667	3291546	47 09.7510	65 05.7548	4.1	Grey sand
4	Eckman Grab	212668	3291600	47 08.4765	65 05.9264	3.8	Brown sand
5	Eckman Grab	212669	3291611	47 07.2150	65 06.0709	7.1	Brown sand
6	Eckman Grab	212670	3291620	47 07.1257	65.08.0988	6.6	Brown mud
7	Eckman Grab	212671	3291630	47 05.7665	65 08.1461	7.3	Brown mud with sand
8	Eckman Grab	212672	3291643	47 08.4230	65 08.0133	6.2	Thin veneer of mud over black red; shells
9	Eckman Grab	212673	3291659	47 09.7681	65 07.7857	6.4	Light brown jelly over sandy silt, some shells
10	Eckman Grab	212674	3291704	47 11.0331	65 07.7316	7.5	Thin brown mud veneer over grey sand
11	Eckman Grab	212675	3291813	47 09.6600	65 09.8166	6.7	Light brown veneer over grey mud, organic
12	Eckman Grab	212676	3291824	47 08.4286	65 09.9763	6.4	Light brown veneer over mud
13	Eckman Grab	212667	3291833	47 08.0600	65 09.5450	6.5	Thin brown veneer over black layer; shell fragments
14	Eckman Grab	212678	3291843	47 07.0760	65 10.1360	6.2	Thin brown veneer over sandy gravel, black sediment
15	Eckman Grab	212679	3291857	47 06.8590	65 10.1830	6.3	Light brown veneer over black mud; minor shell hash
16	Eckman Grab	212680	3291909	47 05.6990	65 10.1740	6.6	Brown mud
17	Eckman Grab	212681	3291920	47 04.4220	65 10.2730	6.2	Light brown mud over darker mud
18	Eckman Grab	212682	3291930	47 03.0880	65 10.3570	5.4	Thin brown veneer over dark grey mud; minor sand
19	Eckman Grab	212683	3291942	47 05.5510	65 12.3380	6.5	1cm veneer brown mud over brown-black mud
20	Eckman Grab	212685	3301441	47 05.4565	65 14.1916	4.5	Brown mud veneer (jelly) over more cohesive clay
21	Eckman Grab	212686	3301533	47 06.9117	65.14.0893	9.4	Brown clay over dark clay; very cohesive, surface oxidization
22	Eckman Grab	212687	3301545	47 08.1622	65.11.9761	8.3	2cm of light brown mud over black mud with eel grass
24	Eckman Grab	212689	3301631	47 06.8992	65 12.1598	4.1	Brown mud, minor sand
27	Eckman Grab	212694	3301809	47 06.9028	65 11.1740	5.2	2cm veneer of light brown clay over darker cohesive clay
29	Eckman Grab	212698	3301849	47 06.9010	65 13.1680	5.2	Thin light brown clay over darker brown clay, minor shell hash
31	Eckman Grab	212700	3311353	47 01.2240	65 30.3510	6.7	Olive grey medium sand with gravel, grass, leaves
32	Eckman Grab		3311435	47 01.1903	65 30.8190	6.4	No sample
33	Eckman Grab	242825	3311437	47 01.1513	65 30.7792	6.4	Medium olive grey clay, sand, shells
34	Eckman Grab	242826	3311443	47 01.3400	65 29.7210	8.0	Medium grained sand
35	Eckman Grab	242827	3311448	47 01.5770	65 28.9180	6.1	Sand only
36	Eckman Grab	242828	3311529	47 04.8960	65 20.7600	10.7	Silty sand with shell hash
38	Eckman Grab	242832	3311647	47 00.9780	65 30.6820	10.1	

Benthos corer

Stn No	Station	Refer No	Day/Time	Latitude	Longitude	Depth	Length	Comments
23	Core	212688	3301605	47 08.1680	65 11.9810	8.4	66cm	Light brown mud over grey brown; very fluid
25	Core	212690	3301700	47 06.9240	65 12.0810	4.1	47cm	Veneer of sand and gravel over sand mud, strong organic smell
26	Core	212693	3301731	47 07.0670	65 10.1340	5.6	58cm	Light brown clay over dark grey clay, no grit
28	Core	212695	3301817	47 06.9028	65 11.1740	5.2	60cm	Light brown veneer over sand, grey clay layer at bottom
30	Core	212699	3301853	47 06.9010	65 13.1680	5.2		Light brown clay over darker
37	Core	242829	3311434	47 04.8960	65 20.7600	10.7	59cm	Olive grey, with layers of wood chips

Appendix VIII Summerside samples

Station	Station Type	Ref No.	Day/Time	Latitude	Longitude	Water Depth	Comments
1	Eckman grab	212650	3220925	46.38297	63.38297		Sand
2	Eckman grab	212651	3220936	46.37995	63.37995		Rocks and Sand
3	Eckman grab	3220945					No sample
4	Eckman grab	3220951					No sample
5	Eckman grab	212652	3220955	46.37202	63.37202		Sand
6	Eckman grab	212653	3221002	46.37347	63.37347		Rocks and Sand
7	Eckman grab	3221007					No sample
8	Eckman grab	212654	3221014	46.37268	63.37268		No sample
9	Eckman grab	212655	3221020	46.35245	63.35245		Rocks, Sand Shells
10	Eckman grab	3221027					No sample
11	Eckman grab	3221035					No sample
12	Eckman grab	3221042					No sample
13	Eckman grab	212656	3221050	46.37273	63.37273		Mud

Appendix IX Grab sample photographs – Miramich - November 2003

Note: Times are shown in AST as MM/DD/YYYY HH:MM:SS

Miramichi Nov 2003



2003-60_08.JPG
2003:11:25 13:43:57



2003-69_18.JPG
2003:11:25 16:29:41



2003069_01.JPG
2003:11:25 12:21:55



2003069_01a.JPG
2003:11:25 12:21:41



2003069_02.JPG
2003:11:25 12:33:39



2003069_02a.JPG
2003:11:25 12:33:58



2003069_03.JPG
2003:11:25 12:46:37



2003069_03a.JPG
2003:11:25 12:46:57



2003069_04.JPG
2003:11:25 13:00:36



2003069_05.JPG
2003:11:25 13:10:28



2003069_06.JPG
2003:11:25 13:19:39



2003069_07.JPG
2003:11:25 13:31:08



2003069_09.JPG
2003:11:25 13:56:26



2003069_10.JPG
2003:11:25 14:04:19



2003069_11.JPG
2003:11:25 15:14:03



2003069_12.JPG
2003:11:25 15:24:44



2003069_13.JPG
2003:11:25 15:34:09



2003069_14.JPG
2003:11:25 15:43:30



2003069_15.JPG
2003:11:25 15:57:39



2003069_16.JPG
2003:11:25 16:09:08



2003069_17.JPG
2003:11:25 16:20:08



2003069_19.JPG
2003:11:25 16:42:31



2003069_20.JPG
2003:11:26 11:42:16



2003069_21.JPG
2003:11:26 12:34:40

Grab Sample Photographs

Miramichi Nov 2003



2003069_22.JPG
2003:11:26 12:45:47



2003069_24.JPG
2003:11:26 13:31:33



2003069_27.JPG
2003:11:26 15:10:08



2003069_29.JPG
2003:11:26 15:48:29



2003069_31.JPG
2003:11:27 10:52:19



2003069_33.JPG
2003:11:27 11:37:39



2003069_33a.JPG
2003:11:27 11:37:03



2003069_34.JPG
2003:11:27 11:43:46



2003069_35.JPG
2003:11:27 11:48:45



2003069_36.JPG
2003:11:27 12:29:16



2003069_38.JPG
2003:11:27 13:47:08

Appendix X Navigation configuration for Matthew 2003069
Plotting Room Layout

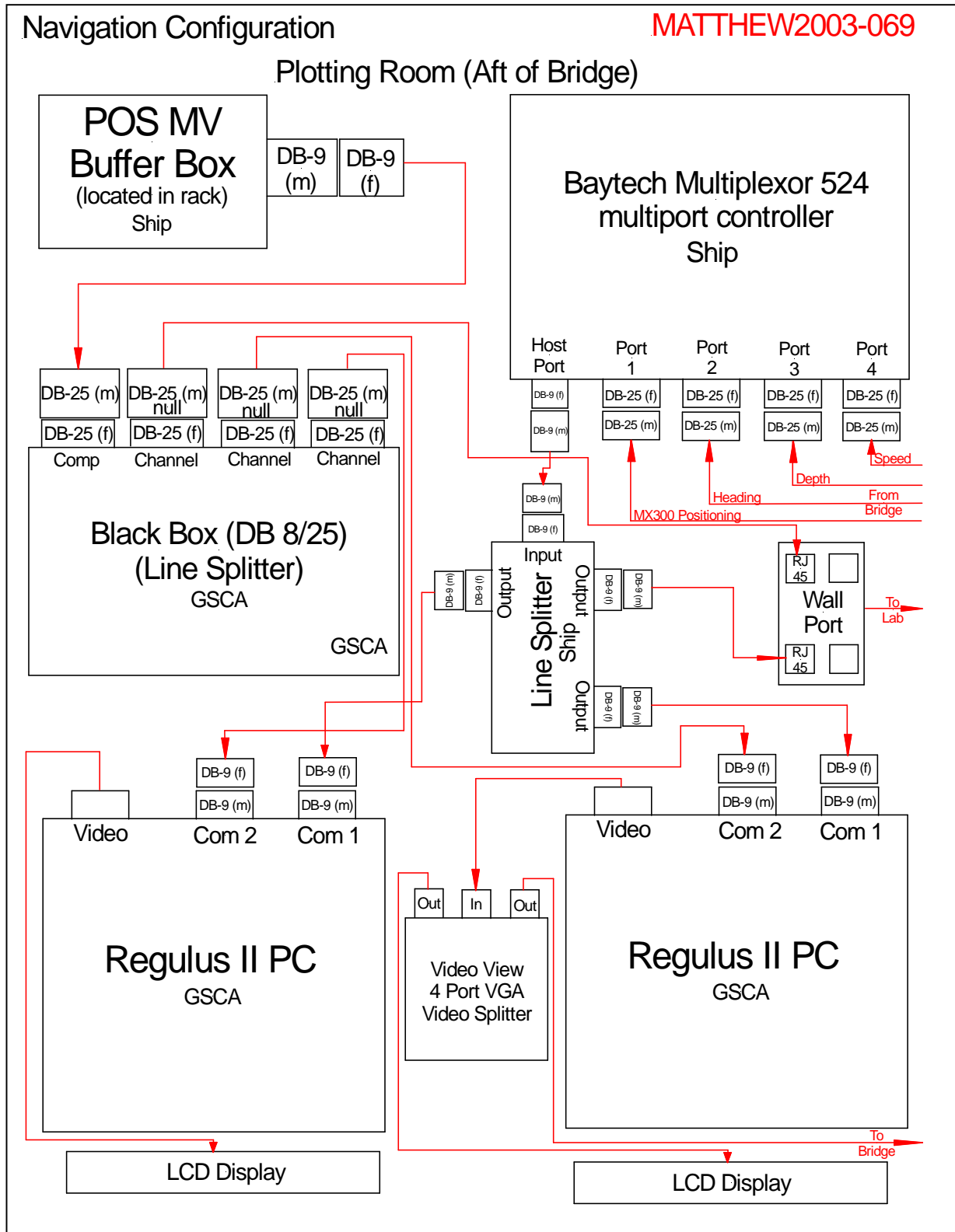

Bridge Connections

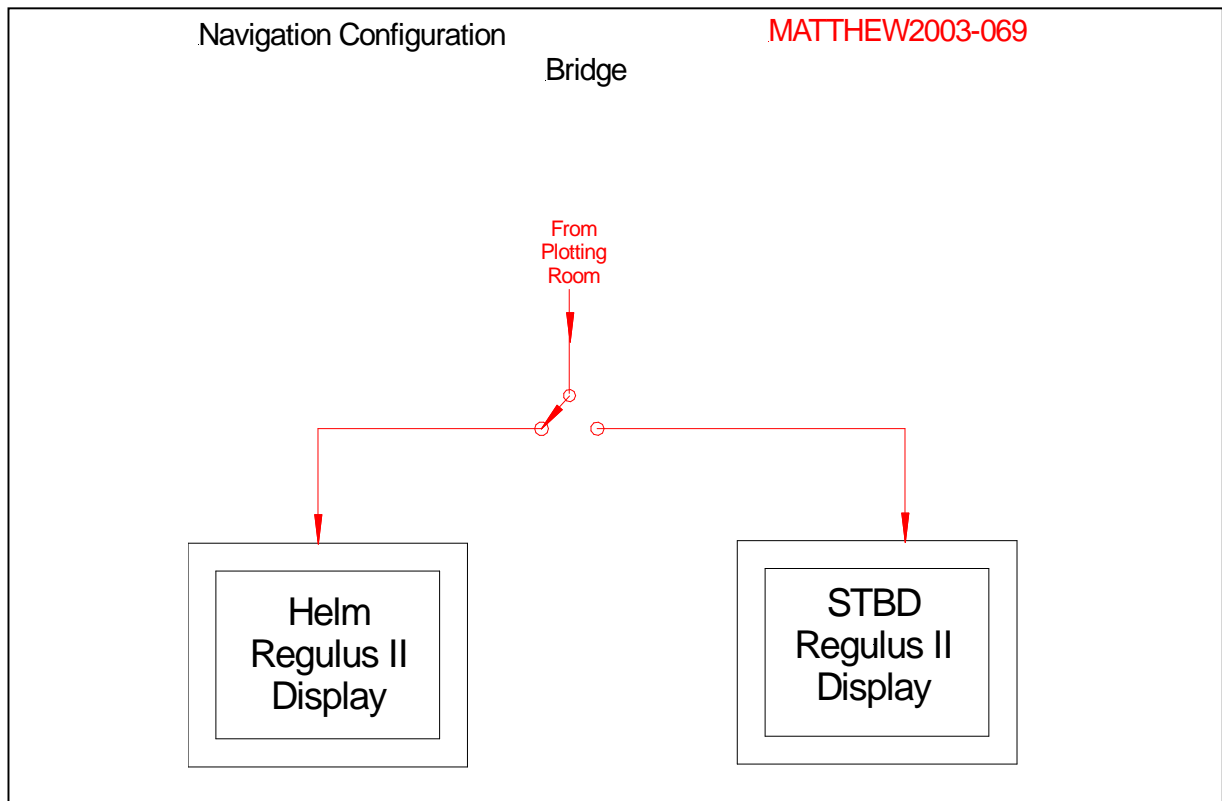

Main Lab Connections

