



Energy, Mines and
Resources

Energie, Mines et
Ressources

**BEDFORD INSTITUTE
OF OCEANOGRAPHY**

**INSTITUT OCÉANOGRAPHIQUE
DE BEDFORD**

BEDFORD INSTITUTE OF OCEANOGRAPHY

TOWING WINCH INVESTIGATION

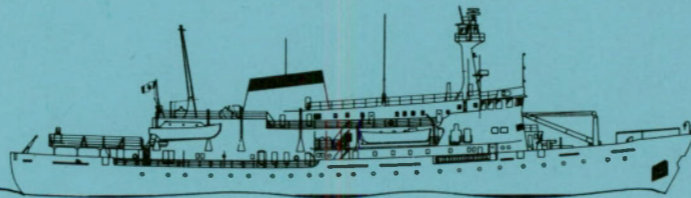
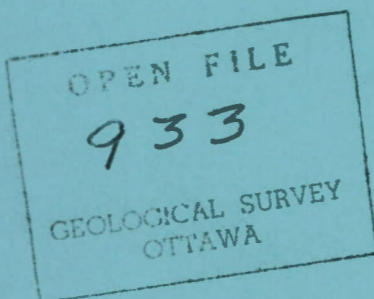

Canada

This document was produced
by scanning the original publication.

Ce document est le produit d'une
numérisation par balayage
de la publication originale.

Report

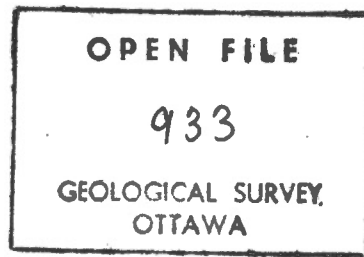

BEDFORD INSTITUTE OF OCEANOGRAPHY
TOWING WINCH INVESTIGATION

Prepared for

Mr. K. Manchester
Atlantic Geoscience Centre
Geological Survey of Canada
Bedford Institute of Oceanography
P.O. Box 1006
Dartmouth, N.S.

Submitted by

WHITMAN, BENN & ASSOCIATES LIMITED
CONSULTING ENGINEERS

HALIFAX, N.S.

TABLE OF CONTENTS

	<u>PAGE</u>
1.0 INTRODUCTION	1
2.0 BACKGROUND INFORMATION	1
2.1 General	1
2.2 Discussion with Users	3
2.3 Discussion with Winch Manufacturers	14
2.4 Discussion with Cable Suppliers	18
3.0 TECHNICAL CONSIDERATIONS	22
3.1 Summary Requirements	22
3.2 Winch Selection Criteria	23
3.3 Single Drum Versus Traction Winches	24
3.4 Discussion	27
3.5 Recommended Winch	28
3.6 Ancillary Equipment	29
3.7 Other Considerations	30
3.8 Piston Coring and Rock Core Drilling	31
3.9 Traction Winch Alternate	32
4.0 EVALUATION OF BIO VESSELS	32
4.1 CSS Hudson	32
4.2 CSS Baffin	33
4.3 CSS Dawson	34
5.0 CONCLUSIONS	34
APPENDICIES	
1. NAMES AND ADDRESSES OF USERS, WINCH MANUFACTURERS, AND CABLE SUPPLIERS	
2. WINCH PERFORMANCE SPECIFICATION	
3. CABLE PERFORMANCE SPECIFICATION	
4. TERMS OF REFERENCE	

1.0 INTRODUCTION

This study, initiated by Mr. K. Manchester of the Bedford Institute of Oceanography (BIO), is concerned with an investigation into the type, performance and feasibility of installing a towing winch on BIO ships, Hudson, Baffin and Dawson.

The primary purpose of the winch is to tow deep ocean survey instrumentation, such as the Sea-Marc system, in order to acquire survey information in water depths up to 20,000 feet. A secondary requirement is that the winch be capable of piston coring to depths of 20,000 feet with a 3,000 lb corer, and also capable of handling the BIO rock core drill in water depths up to 11,600 feet.

Of primary importance is the requirement that the winch system be portable and easily moved from ship to ship. It is also important that the winch system be self-contained, probably with its own diesel powered prime mover, and be capable of accepting multiple or interchangeable drums to allow for easy changing of cables.

Further details of the study requirements are contained in the Terms of Reference which accompany this report as Appendix 4.

2.0 BACKGROUND INFORMATION

2.1 General

While Whitman, Benn & Associates Limited has some familiarity with the existing winches and handling equipment used on Bedford Institute of Oceanography vessels, they are not particularly familiar with the design of deep tow systems. Consequently, it was never intended that Whitman, Benn design a custom winch and handling system, but rather that they become familiar enough with the requirements to specify a system suited to the Bedford Institute of Oceanography's needs. This goal was achieved through a comprehensive telephone survey of users of similar deep tow systems, both institutional and private organizations, and through discussions with Canadian and American winch manufacturers and cable suppliers.

This section summarizes the results of the telephone survey and the various discussions upon which the selection of the system was based.

2.2 Discussion with Users of Deep Tow Vehicles

Lamont Doherty Geological Observatory - The deployment of deep towed vehicles was discussed with Dr. W. Ryan of Lamont Doherty Geological Observatory on October 7, 1981. Dr. Ryan operates a Sea-Marc mapping system and is probably the person most experienced with the deployment of the system. He provided the following information:

- In deep water the Sea-Marc system normally tows with a cable length of approximately 1.5 times the water depth. This is consistent with an optimum towing speed of approximately $1\frac{1}{2}$ knots in deep water. Therefore, to achieve a towing depth of 20,000 feet, a cable length of approximately 30,000 feet is required.
- The ultimate breaking strength of the cable used by Lamont Doherty is between 30,000 and 33,000 lbs., and the normal working load in the deep water towing configuration between 10,000 and 15,000 lbs. Under adverse weather and operating conditions, this load can go as high as 20,000 to 22,000 lbs. The cable is a .68 inch diameter coaxial cable with two layers of counterwound armour.
- The electrical characteristics of the cable are not that important to the deployment of the 500 kHz Sea-Marc system. However, in the case of video systems a 4 MHz system is required, and, according to Dr. Ryan, this requires a larger diameter cable. Dr. Ryan indicated that .68 inch diameter is probably the smallest practical diameter and that larger cables introduce a problem with winch drum size.
- The Sea-Marc system normally operates between 300 ft. and 1,600 feet above the sea floor. Therefore, to avoid rapid changes in bottom topography, a fairly high haul rate is desirable. The range of values quoted varied from 100 feet/min., which was considered too slow, to 300 feet/min., which was considered desirable for short term (3 to 4 minutes) operation. Generally, 200 feet/min. is a reasonable and practical operating value, but 300 feet/min. would be useful if it could be readily obtained. These line speeds are associated with the normal working load of 10,000 to 15,000 lbs.

In answer to questions on the handling systems used by Lamont Doherty, Dr. Ryan provided the following information:

- Lamont Doherty have experienced numerous problems with traction winches and cable life has been extremely short (1 or 2 months). With cables costing between \$80,000 and \$100,000, this is a serious problem.
- Lamont Doherty are presently undertaking the design of a single drum winch system because they are of the opinion that it is more desirable to store the cable under high tension than to subject it to the more frequent bending and wear associated with a traction winch system.
- They consider the design of the level wind mechanism is extremely important in the case of a single drum winch and consequently they have given Lebus International a contract to design a suitable mechanism for them. They anticipate using a Lebus grooved drum in association with the Lebus spooling mechanism.

Other features of the single drum winch they are designing include:

- the use of a diesel hydraulic power source;
- the use of a low noise slip ring assembly which permits easy access;
- the use of split grooving in association with the Lebus level wind system; and
- the use of a non-removable winch drum because they prefer to change cables rather than purchase interchangeable winch drums.

Dr. Ryan was contacted again on November 16, 1981 and further discussion took place as to the most suitable type of winch. The following items were discussed:

- Dr. Ryan is proceeding with the purchase of a large single drum winch to deploy the Sea-Marc. However, he is somewhat concerned as to his choice of winch because while Lamont Doherty have considerable experience with coring winches, and definitely favour large single drum winches for this application, he is not certain that a single drum winch is the most appropriate for the deployment of a deep tow vehicle.
- Dr. Ryan confirmed that the values of cable tension quoted for the deployment of Sea-Marc during the earlier telephone conversation were measured and not estimated

values. That is, 10,000 to 15,000 lbs. working load and 20,000 to 22,000 dynamic load.

- Dr. Ryan agreed that a design line speed of 200 feet/min, was quite realistic. He also agreed with Mr. Jim Kosolas of International Submarine Technology that values above 100 feet/min. were undesirable under normal operating conditions, and emphasized that higher operating values were primarily associated with the need to avoid obstacles when operating under conditions of rapidly changing bottom topography.
- The possibility of using a V-grooved traction winch with large diameter bull wheels was suggested to Dr. Ryan. He had no basic criticism of this suggestion and agreed that winch selection is primarily dependent upon the properties of the cable and whether or not it is more desirable to store the cable under high tension, or to pass the cable over numerous turns of a bull wheel.
- With regards to motion compensating systems, Dr. Ryan agreed with Jim Kosolas of IST that these systems are not required for the deployment of the Sea-Marc because the vehicle is decoupled from the tow cable by means of a large depressor.

Mr. Dale Chayes of Lamont Geological Observatory was contacted on December 2, 1981 and he provided the following information:

- Lamont Doherty have experienced numerous problems with the traction winch system they use for deploying the Sea-Marc. While some of these problems are related to the age of the equipment and lack of proper maintenance, others are directly related to the use of a traction winch in this application.
- Where the application is not well defined, traction winches provide flexibility, for example, interchangeable traction heads can be used for different cable sizes and types, and spooling under low tension is advantageous under certain circumstances.
- When using traction winches under high tension conditions, cable lubrication can be squeezed out resulting in cable slippage on the traction heads. A Lamont Doherty cable failed this summer due to the heat generated by a slipping cable.

- Lamont Doherty are presently designing a new winch. In developing the design considerable emphasis has been placed on minimizing the number of cable bending cycles and, in this regard, they consider single drum winches to be superior to traction winches. Single drum winches weigh less, require less space and are less complex than traction winches.
- Single drum winches are only appropriate if perfect level winding can be achieved, and to meet this criteria Lamont recommend Lebus grooving and a Lebus spooling mechanism.
- For round wires such as used for the deployment of the Sea-Marc, the Lebus spooling mechanism works extremely well, but this is not the case with non round wire such as a 3 x 19 construction (basically triangular).
- Storage under tension in a corrosive environment is undesirable and Lamont intend to wash, blow dry and lubricate their cable after use to minimize corrosive action.
- The operation and understanding of single drum winches is an order of magnitude simpler than traction winches and this is beneficial when operating in the marine environment with inexperienced personnel. This is frequently the situation on oceanographic ships.
- A suitable bend radius to cable diameter ratio is either 40 times the cable diameter or 400 times the diameter of the largest individual armour wire. For the 0.68 inch diameter cable used for deploying the Sea-Marc, Lamont have determined that the winch core diameter should be at least 30 inches and the fleet angle compensator diameter 32 inches.
- It is important to consider the concept of fail safe systems in a general context. For example, what happens if the ship's power fails? Can you bring in or pay out cable? What happens if the motor burns up? Can you recover the system?
- The range of speed for deployment and recovery of the Sea-Marc is between 100 feet/minute and 200 feet/minute, but for slowly changing bottom topography Lamont would like to achieve speeds as low as 1 to 2 feet/minute. Since traction winch systems do not function well at low speed, this is another factor in favour of single drum

winches. The slower response speed of single drum winches is not critical to the deployment of the Sea-Marc.

- Lamont utilize a towing crane of the type developed by Scripps Oceanographic Institution for deploying the Sea-Marc. This has proved more advantageous than a conventional A-frame because it permits far greater ship maneuverability. The cable passes into the base of the towing crane, along the boom, over a sheave and then to the Sea-Marc vehicle. The crane turns on its base to the optimum alignment and permits greater ship maneuverability. This is an important consideration because with ships travelling at $1\frac{1}{2}$ to 2 knots, it is difficult to maintain steerage and any system that improves the ship's maneuverability is of great benefit.

International Submarine Technology Limited - Mr. J. Kosolas of International Submarine Technology Limited was contacted on October 29, 1981 and he provided the following information:

- A motion compensating system would not be cost effective with the Sea-Marc system unless it could be obtained at little, if any, cost (under \$10,000).
- Further discussion of motion compensating systems confirmed that there is a direct coupling between a ship and a towed body, even when 30,000 feet or more of cable are deployed. According to Mr. Kosolas, one can ignore the cable catenary and basically consider the cable between the towed body and the ship to be a straight line. He based this statement on his experience with these systems and stated that measurements have confirmed this direct coupling and also indicate that with the drag of the towed body approximately equal to the drag on the cable, the angle of the cable leaving the towed body is similar to the angle of the cable leaving the ship.
- The reason that direct coupling between the ship and the towed body is not a problem with the Sea-Marc system is that the Sea-Marc vehicle is neutrally buoyant and decoupled from the tow cable by a large depressor and approximately 300 feet of line.
- In response to a question as to the desirability of carrying out a theoretical design study taking into account the Sea-Marc, its tow cable, the winch and the motion of the ship, Mr. Kosolas indicated that some deep tow sys-

tems with heavier and larger bodies have approached resonant conditions. Resonance is not a problem with the Sea-Marc because of the relatively low weight and drag of the depressor.

- The winch International Submarine Technology use to deploy the Sea-Marc system utilizes two 5 ft. diameter urethane lined V-groove traction wheels and a plain storage drum. The cable passes over approximately 270° of each traction wheel and is stored on a storage winch at between 200 and 300 lbs tension. The system was originally designed and built by Pengo. The storage drum holds approximately 30,000 feet of .7 inch diameter cable.
- The line speed recommended by Mr. Kosolas was approximately 100 feet/min. for both deployment and recovery since rates in excess of this value are likely to damage the electronics.
- With regard to slip rings, Mr. Kosolas indicated that the slip rings they utilize are manufactured by Meridian Laboratories of Middleton, Wisconsin. These slip rings are a mercury type slip ring with a 20 amp capability at 5,000 volts. They are essentially noise free and have provided satisfactory results.
- Mr. Kosolas recommended that the cable be washed down with fresh water before storage, and, when not in use, the winch should be covered. In his opinion, this considerably increases cable life.

Sound Ocean Systems Incorporated - Mr. Ted Brockett of Sound Ocean Systems Incorporated was contacted on November 12, 1981 and he provided the following information:

- A motion compensating system is not required for the deployment of the Sea-Marc since the towed body is decoupled from the cable by a depressor.
- Mr. Brockett was strongly against either the use of a single drum winch or a multiple pass type of traction winch. He favours a traction winch system using two large bull wheels with rubber liners of the type manufactured by Pengo. He emphasized this type of V-groove traction winch because of the high cost of electro/mechanical cable and the resulting need to preserve cable life. In Mr. Brockett's opinion, cable life is increased both by the use of large diameter bull wheels (54 to 60 inches) and storage under low tension.

- Mr. Brockett confirmed the estimates of working load (10 to 15,000 lbs.) provided by Dr. Ryan of Lamont Doherty Geological Observatory. Discussion of line speed confirmed the value of 100 feet/min. given by Mr. Kosolas, but Mr. Brockett also acknowledged that a value of 200 feet/min. might well be desirable when operating under conditions of rapid changing bottom topography.
- Mr. Brockett felt that it would be far more advantageous to purchase a standard winch of 20 to 25,000 lbs. line pull at 100 feet/min. from an existing manufacturer than it would be to custom design a unit.
- With regard to the problem of cables jumping off traction wheels, Mr. Brockett acknowledged that this did occur on one occasion. He considered, however, that with the proper layout of deck equipment, this problem could be avoided. He further indicated that on the occasion that the cable jumped off the traction wheels, they were utilizing a system without fail safe braking and operating under extremely severe conditions.
- Mr. Brockett indicated that the use of a hydraulically operated A frame on the stern is perhaps the most ideal configuration for the deployment and recovery of the Sea-Marc vehicle. He further indicated that his experience with tension compensating sheaves suspended from the A frame was not particularly good and he was now of the opinion that large diameter (48 inches) uncomplicated sheaves were by far the most appropriate and troublefree.

Westinghouse Oceanic - Mr. Haury of Westinghouse Oceanic was contacted on October 14, 1981 and he provided the following information:

- Westinghouse Oceanic have developed a performance specification for a winch and handling system to deploy a deep tow vehicle for the U.S. Navy. The actual installation has been designed by Techwest Enterprises Limited of Vancouver, B.C.
- The system utilizes a motion compensating "A" frame because the vehicle, even at a depth of 20,000 feet, is extremely sensitive to ship motion. The motion compensating system is, to Mr. Haury's knowledge, the first system that actually monitors ship motion and utilizes a control system that moves the "A" frame in response to commands from a microprocessor while the winch remains stationary.

- The winch is a traction type and utilizes two Hagglund low speed hydraulic motors. The storage drum has a core diameter of 28 inches, a flange diameter of 5 feet, and is 6 feet long. It accommodates approximately 108 turns and 22 wraps of .7 inch diameter coaxial cable for a total length of 30,000 feet. The traction wheels are 28 inches in diameter and to obtain the required maximum line pull of 25,000 lbs., there are 6 grooves in each of two wheels. The normal operating tension is 14,000 lbs. at full depth.

Deep Sea Ventures - Mr. R. Kaufman of Deep Sea Ventures was contacted on October 13, 1981 and he provided the following information:

- Deep Sea Ventures own and operate the research vessel R.V. Prospector out of San Diego, California. This vessel has a custom winch which was installed for Deep Sea Ventures by the Newport News Shipbuilding Company. The winch is installed below deck and utilizes an electrical DC motor drive. The winch is a single drum installation that spools 2 sizes of cable; 35,000 feet of 5/8 inch dredge wire and 25,000 feet of 3/4 inch diameter coaxial TV cable. The flange diameter is 8 feet and the drum length 8 feet. The coaxial TV cable is spooled using a Lebus level wind system.
- Deep Sea Ventures have operated their system for approximately 12 years and have only experienced cable failure on one occasion. They are basically satisfied with the existing winch system, but some modifications, including an increase in drum and side plate strength, have been considered.

Woods Hole Oceanographic Institution - Captain R. Dinsmore of the Woods Hole Oceanographic Institution was contacted on October 15, 1981 and he provided the following information:

- Woods Hole are planning to install a U.S. Navy owned traction winch manufactured by Western Gear of Seattle on their research vessel, the Atlantis II. The unit will be semi-portable and will be suitable for installation on other vessels. It is to be an electro-hydraulic system powered by the ship's electrical system.
- During a discussion of the merits of traction and single drum winches, Captain Dinsmore indicated that some of the problems now experienced with single drum winches and spooling mechanisms are associated with inadequate

quality control on the wire. That is, they have recently discovered that some coaxial cable is outside of the specifications. For this reason, traction winches are perhaps more attractive.

- Woods Hole do not intend to purchase a motion compensating system, since, in their experience, this requirement is unnecessary. However, they acknowledge that these devices are of some use if they can be purchased at a reasonable price.
- Captain Dinsmore provided the following information on the winch they are installing on the Atlantis II. Normal working load 10,000 to 15,000 lbs.; maximum working load 30,000 lbs. (20,000 to 25,000 lbs. for deep tow vehicle); cable diameter .68 inches; haul rate 200 feet/min. to 300 feet/min.; horsepower 200 to 250.

Bedford Institute of Oceanography - The deployment of deep tow vehicles was discussed with Dr. R.L.G. Gilbert, Mr. K. Manchester and Mr. M. Chin-Yee of the Bedford Institute of Oceanography on November 4, 1981. The following information was provided:

- The BIO have experienced little difficulty with slip rings providing there is sufficient room to access the end of the drum shaft.
- In the opinion of both Dr. Gilbert and Mr. Manchester, towed bodies normally act as though they are directly connected to the ship regardless of the depth or length of line deployed unless specific arrangements, such as that used for the Sea-Marc system, are used to decouple the body from the ship.
- During the discussion of traction winch systems, Dr. Gilbert mentioned that cables have jumped off traction wheels on several occasions. Since this is obviously a crisis situation, it is important that the design of the new system take this into account.
- The subject of electro-hydraulic and diesel hydraulic drives was discussed, and it was concluded that an electro-hydraulic drive would probably be the most desirable because of initial cost savings and the fact it is always possible to rent a diesel electric generator if adequate ship service power is not available.
- With regards to the ratio of line out to operating depth, a value of 1.7 was suggested. This agrees favourably

with the value of 1.5 provided by Dr. Ryan of Lamont Doherty Geological Observatory.

- Discussion with Mr. Manchester on the subject of line speed suggested that the values given by Dr. Ryan of Lamont Doherty might be more appropriate than those of Jim Kosolas of IST simply because the operating requirements of the BIO are closer to those of Dr. Ryan. That is, whereas Jim Kosolas suggested values of 100 feet/min., the BIO will probably require line speeds in the order of 200 feet/min. Even higher values, while perhaps desirable, will require too great a horsepower.
- Mr. Manchester emphasized the requirement for a clean system, that is, a system which restricts the number of small hydraulic lines in the vicinity of the winch, and where possible, boxes in the hydraulic lines. His explanation for this requirement, is that with the ships covered in ice, crew members are likely to beat the ice off with mallets.
- There was some discussion of the latest deep coring techniques which use synthetic ropes such as kelvar to overcome the problem with conventional wire cable of cable weight exceeding the breaking strength. Due to the many problems associated with high tension storage of synthetic ropes, the traction winch system, where the rope is stored under low tension, is by far the most desirable. Storage under low tension prevents the bottom layers of synthetic rope having their cross section distorted.

Scripps Oceanographic Institution, San Diego, California -
Mr. Boegeman, Engineering Section Head, Deep Tow Project,
University of California was contacted on November 25th, 1981, and he provided the following information:

- He has been involved with deep tow vehicles for approximately 18 years, and has discussed their deployment with a large number of individuals and organizations.
- Scripps presently utilize a traction winch system consisting of a storage winch and 2 bull wheels for the deployment of deep tow vehicles. The bull wheel diameter is approximately 36", and four or five turns are required to develop the required line tension.
- Mr. Boegeman indicated that the majority of people in the deep tow business have standardized on a .680" diameter

electro/mechanical cable. This diameter is consistent with the deployment of towed vehicles to about 20,000 ft. The advantage of using this standard cable is that several cable manufacturers are familiar with it, and considerable development work has gone into its construction.

- Electro/mechanical cable is more susceptible to damage than conventional wire cable because of the soft core which permits the armouring to deform.
- During the early stages of the deep tow project, most failures were associated with broken strands in the outer armour, this mode of failure generally being a result of winch problems, inadequate layout of deck equipment, and the use of sheaves with too small a diameter. The second mode of cable failure was associated with water leaking into the electrical conductor. This is not a problem if the cable is properly constructed with non-hosing properties, but without these properties, any leakage effectively ruins the cable.
- Mr. Boegeman said that Scripps used to specify counterwound torque balanced armouring, where torque balancing was achieved by using large diameter wires for the inner layer and small diameter wires for the outer layer. Unfortunately this latter feature makes torque balanced wire more susceptible to wear and damage, and, as a consequence, Scripps no longer specify torque balanced wire and use large diameter wires for both the inner and outer layers.
- Mr. Boegeman indicated that a useful rule of thumb for the .68" diameter cable is that the tension is comprised of approximately $\frac{1}{2}$ lb. per foot of water depth (not length of cable deployed) plus the drag on the towed vehicle itself. In the case of the Sea-Marc vehicle, this gives a loading of between 10,000 and 12,000 lbs. At Scripps, they start to become concerned with cable failure when the load approaches 15,000 lbs., since unmeasured bending stresses make this load equivalent to a 20,000 lb. direct line pull. Consequently, since the yield strength of this type of cable is approximately 21,000 lbs., it is desirable to keep measured loadings below 15,000 lbs.
- During the discussion of cable problems, Mr. Boegeman indicated that reverse bends are undesirable, particularly when associated with small diameter sheaves.

- During discussion of the merits of single drum winches, Mr. Boegeman indicated that the most suitable system he has seen for the deployment of deep tow vehicles is the large single drum unit used by Deep Sea Ventures on their vessel R.V. Prospector. He indicated that Deep Sea Ventures has achieved far greater cable life than any other organization of which he is aware, and he basically attributes this to the fact that the winch is built into the vessel, is of particularly large and heavy construction, and utilizes both a large winch drum diameter and large sheaves.
- Mr. Boegeman said that cable life could be greatly extended by proper care. For example, during the last recovery on any particular cruise, Scripps pay out the longest length of cable associated with that particular cruise, and during recovery spray on a preservative in order to minimize corrosion.

Racal Decca Company Limited - Mr. R. Hoff and Mr. R. Haas of the Racal Decca Company were contacted on December 7, 1981 and they provided the following information:

- Racal Decca have used two systems to deploy deep tow vehicles; an earlier single drum unit and a more recent traction unit. The single drum unit was associated with a particularly complicated deck layout and numerous problems were experienced with it.
- The traction unit they are now using was manufactured by Crossline Manufacturing of Navasota, Texas. They are having numerous problems with this unit, but now believe that they have found acceptable solutions and all that remains is their implementation.
- Traction units involve more bends in the cable than an equivalent single drum unit, but they are not convinced that a single drum unit is necessarily better.
- It is important to consider the design of the cable and the winch simultaneously. This was not done at the time they designed their unit. They have since spent considerable time discussing the construction and manufacture of cables with Rochester Cables, Vector Cables, Blake Wire and Cable, and the South Bay Cable Company.
- The vehicle they deploy is not the Sea-Marc, but a deep tow vehicle that utilizes a drag chain. A vertical heave compensator is also incorporated into their system, and

they are of the opinion that a compensator is necessary for the deployment of all deep tow vehicles.

- Line speeds of 300 ft/min were quoted for areas of rapidly changing bottom topography. However, because their system utilizes a drag chain and a neutrally buoyant vehicle to set the depth of the vehicle above the sea floor they also said that a rapid recovery rate is not critical.
- They have experienced some problems with the traction sheaves and believe this may be something to do with the choice of sheave material. That is, the material which is A36 steel is too soft for this application. In their opinion, a harder steel is required.
- A motion compensating system is a definite requirement to reduce dynamic loads.
- The diameter of the stern sheave is critical and should be as large as possible.
- The cost of the traction winch system they are utilizing is approximately \$250,000.

2.3 Discussion with Winch Manufacturers

Although discussion took place with numerous winch manufacturers, only that information which has some bearing on the development of the performance specification is recorded in this section.

Fathom Oceanology Limited, Port Credit, Ontario - The requirements of the Bedford Institute of Oceanography winch installation were discussed with Mr. McLerie of Fathom Oceanology Limited at their head office in Port Credit, Ontario. Mr. McLerie was most interested in this project and expressed a keen interest in being put on the list of bidders. Mr. McLerie provided the following information:

- Fathom Oceanology's background is ocean orientated and they have made their name through the marketing of soft nosed cable fairings. They also manufacture variable depth sonar systems for the Canadian, Brazilian, U.S. and Italian navies. The workmanship, finish and testing facilities associated with the variable depth sonar systems were most impressive.
- The subject of faired cable was discussed at some length, and it was concluded that deployment of the Sea-Marc

system is not a faired cable application, simply because it is impractical with 30,000 ft. of cable. Faired cable is normally stored as a single layer on a storage drum and it is not possible to store faired cable of the type manufactured by Fathom in multiple layers. The advantage of faired cable is that it reduces drag and, therefore, for a given operating depth, it enables towing speed to be increased, typically from one or two knots to six or seven knots. This is particularly advantageous when carrying out marine searches or mapping, but the impracticality of storing a long length of faired cable means that the BIO installation will be restricted to a plain cable.

- The "side winder" slip ring mechanism that has been patented by Fathom Oceanology was discussed. This device attaches to the side of the winch in place of conventional slip rings and maintains continuity of electrical signals by utilizing a separate drum for the electrical conductor. The use of this device was subsequently discussed with representatives of the BIO, and their experience with this system has not been good. It is probable that the mechanism is suitable for relatively short cables such as used with the variable depth sonar systems, but is not suitable for long cable lengths.
- Fathom Oceanology has the capability to analyze the performance of systems taking into account vessel motion, sea state, winch performance, and motion compensation system performance. Mr. McLerie was of the opinion that a theoretical study of a system performance would be a desirable step and should be considered in advance of final system selection.

John T. Hepburn Ltd., Toronto, Ontario - The requirements of the Bedford Institute of Oceanography winch installation were discussed with Mr. E. Pfieler, Engineering Head, Winch Division, and Mr. R. Ballentyne Manager, Mechanical Division on October 23rd, 1981 at John T. Hepburn's mechanical manufacturing facility in Toronto, Ontario. They were most helpful and provided the following information:

- If rapid system response is required, a hydraulic drive is the optimum solution because of the high inertia involved with large electric motors. In the case of hydraulic systems, rapid rotational changes are achieved by small movements of a swash plate.
- The response of a single drum winch varies with the position of the cable relative to the take-off diameter and,

therefore, where rapid response is required, it normally requires a fairly sophisticated control system.

- Traction winches are generally preferred because the cable is contained on a storage drum under low tension, and when under tension is contained in grooved bull wheels that minimize cable wear.
- While traction winches are generally preferred, they do involve a certain amount of additional complexity, and, therefore, are generally more expensive. The storage winch is normally a constant tension winch, this being necessary to maintain the tension over the bull wheels. The value of tension is not critical, but tension is required to maintain friction over the bull wheels and prevent cable slippage and resulting impact loads. For this reason, it is necessary to synchronize the storage winch rotation with the rotation of the bull wheels.
- During a discussion of Lebus grooving and spooling equipment, Mr. Pfieler indicated that the area where the crossover of the cable occurs is an area of wear and abrasion.
- The possibility of carrying out a system performance evaluation with and without motion compensation was discussed with Mr. Pfieler and Mr. Ballentyne. They both indicated that this might be a desirable step, but were not totally convinced that such an analysis is necessary. If they were required to carry out an analysis, they would, in all likelihood, have this analysis carried out by a professor at the University of Toronto.

W.C. Markey Co. Ltd., Seattle, Washington - The proposed Bedford Institute winch installation was discussed with Mr. Markey of the W.C. Markey Co. on October 15th, 1981, and he provided the following information:

- The Markey Co. have been marketing single drum winches for approximately 25 years. They have specialized in single drum winches since, in their experience, the hydraulic problems associated with traction winches are detrimental to the image of quality and trouble free installations that they have established over the years. This quality image was supported by Mr. Dinsmore of Woods Hall and also by Mr. Manchester of the BIO.
- The largest winch that Markey have manufactured is a 43,000 ft. 9/16" diameter cable, single drum winch for

the University of Hawaii which is installed on the vessel "Kanakeoki." This particular winch has a core diameter of 30", a face width of 55", and 72" diameter drum flanges. The total weight of the unit is 35,000 lbs. and it has a 100 gal/min, 3,000 p.s.i. hydraulic drive system. This unit is used for dredging and deep sea coring. It has not been used with coaxial cable to Mr. Markey's knowledge.

- In answer to a general question about the drum strength of large single drum winches when spooling under tension, Mr. Markey said that they have solved this problem by manufacturing extremely heavy winch drums. For example, the side plates of the University of Hawaii winch are approximately 4" thick.

TechWest Enterprises, Vancouver, B.C. - The proposed Bedford Institute of Oceanography winch installation was discussed with Mr. Thomas of TechWest Enterprises on October 15th, 1981, and he provided the following information:

- A traction winch would be most suitable in this application.
- TechWest Enterprises' speciality is the design of winches and motion compensating systems, and they have designed systems for both the British and the Americans. Their strength is the ability to make performance predictions on towed systems that incorporate motion compensating devices. A motion compensation system that they manufactured for Westinghouse Oceanic of the U.S. monitors 5 of the 6 degrees of freedom associated with vessel motion.
- Mr. Thomas was strongly in favour of carrying out a system analysis, whether or not a motion compensation system was involved.

Tension Stringing Equipment, Louisiana, U.S.A. - The requirements of the Bedford Institute of Oceanography winch installation were discussed with Mr. Barry Crawford of Tension Stringing Equipment on November 13th, 1981, and he provided the following information on V-grooved traction winches (V-grooving refers to the shape of the urethane traction wheel liners):

- Mr. Crawford indicated that it is the V-grooving that provides the friction necessary to reduce the cable tension and it is this grooving that accounts for the fundamental difference between the V-groove type of traction winch and the conventional multi-pass traction

winch which utilizes U-grooving. The V-grooved traction wheel liners are generally sized for a particular cable, although, providing there is not too large a size difference, other cables can be used.

- In the opinion of Mr. Crawford, it would be possible to use a V-groove traction winch for deployment of the rock core drill and also for piston coring.
- Basically, a V-groove traction winch is a traction winch consisting of two large diameter sheaves and a storage winch; the large diameter sheaves being lined with V-grooved urethane liners. The reason behind the selection of the large diameter bullwheels is that smaller diameters are prone to result in damaged cable insulation and damaged electrical conductors.
- The general standard for sizing traction wheel diameters is, in the case of steel cables, 30 to 35 times the cable diameter, and in the case of electro/mechanical cables, 70 times the cable diameter.

2.4 Discussion with Cable Manufacturers

Rochester Cables, Culpepper, Virginia - The use of electro/mechanical cables to deploy deep tow vehicles was discussed with Mr. A.G. Berian of Rochester Cables Limited on November 25, 1981, and he provided the following information:

- He is the author of two papers, "Design and Handling Factors in the Reliability and Life of Electrical Wire Lines" and "Specifying and Using Contra-Helically Armoured Cables for Maximum Life and Reliability".
- Mr. Berian indicated that 80% of the systems utilizing electro/mechanical cable are in the oil field logging industry and almost all utilize a single drum winch with $\frac{1}{2}$ inch diameter electro/mechanical cable. He estimated that there are approximately 5,000 of these systems worldwide and the single drum concept is favoured because it minimizes the weight of the machinery and the space requirement. These units are portable land based units. A typical single drum winch used for this application utilizes 18,000 to 20,000 feet of cable and generally provides storage for 26,000 feet.
- In the case of single drum winches, Mr. Berian indicated that the larger the number of wraps the greater the care that has to be taken with the cable. He further indicated that with a single drum system it is desirable to

store the cable under high tension. When it was pointed out that during the latter stages of the recovery of the Sea-Marc vehicle the cable is under relatively low tension he suggested that the traction winch alternative might be more appropriate.

- Mr. Berian emphasized that cable life is dependent upon two variables - bend radius and flexure of the cable. Empirical graphs contained in wire rope manufacturing company catalogs are representative of electro/mechanical cable performance and provide a comparative measure of the effect of bend radius on cable life. The fatigue life of electro/mechanical cable is somewhere between 15,000 and 20,000 flexure cycles, where a cycle is considered to have occurred when a change in bend radius of the cable takes place. For example, when a cable changes direction over a pulley, even by as little as 10°, this is considered a flexure cycle.
- The subject of reverse bending of the cable was discussed with Mr. Berian and he indicated that reverse bends are detrimental to cable life unless the bull wheels are approximately 5 times the diameter of an individual bull wheel apart. A rough estimate as to the loss of fatigue life associated with a reverse bend is in the order of 25% of total cable life.
- Mr. Berian is not familiar with V-grooved urethane lined bull wheels, but he did not see anything fundamentally wrong with the concept.

The following information was extracted from Mr. Berian's paper "Design and Handling Factors in the Reliability and Life of Electrical Wire Lines".

- The primary causes of electro/mechanical cable damage are in order of occurrence frequency:
 - handling damage;
 - abrasion; and
 - corrosion
- To obtain maximum life and reliability from electrical wire lines, proper handling techniques are necessary in all phases of transportation, storage, operation and maintenance. The steel contra-hellical armour is a complex mechanism which must maintain structural stability to properly interface with equipment and protect the electrical core. An extremely important factor in armour mechanics is maintaining freedom of movement between the

two armour layers, because this freedom is necessary for proper cable flexing. Under load high friction forces tend to limit this freedom and the presence of foreign material in this area increases friction and consequently the susceptibility to damage.

- Proper spooling avoids stress concentrations and nestling of the line and ensures that:
 - the line tension will be sufficiently high to permit layers on the drum to hold near circular cross-sections; and
 - the line tension will be lower than that which will overly compress the core and/or possibly distort the armour at the crossover points.
- Cable is spooled under tension because contra-helical armour resists compressive distortion when under tension much more than when relaxed. Sufficient tension, therefore, is desirable to obtain intimate contact of all cable parts and to ensure that the inner armour wires seat into the armour bedding uniformly.
- The diameter of sheaves should be based on the recommendations of the cable manufacturer and will generally follow the accepted practice of minimum sheave diameter equals 400 times the diameter of the largest armour wire.
- The correct sheave groove design is important to provide proper support to the cable. If the groove is too small, the armour will distort in the groove with a great deal of friction and rapid wear of the armour wires. If the groove is too large, either on initial selection or as a consequence of wear, the cable will become elliptical and therefore cause distortion of the cable cross-section, unusually high inter-armour friction and premature wear.
- The single most important operating principle is the maintenance of line tension to prevent formation of loops which can result in kinks or, under extreme conditions, bird caging. A momentary lack of high tension may also allow the cable to leave the sheave groove and subsequently be crushed on the edge of the groove or on the sheave pin when retensioned.
- Subjecting an electro/mechanical cable to tension in excess of 50% of the cable breaking strength can result in damage by:

- crushing of the armour at the points where turns cross over underlying turns on the winch drum (cross over points); and
- permanent yielding of armour wires at the sheaves causing high wires and possibly damage to the conductor.

Tension Member Technology - Mr. Philip Gibson of Tension Member Technology was contacted on December 3, 1981, and he provided the following information:

- Tension Member Technology are consultants to industry and government regarding cable construction, testing and handling systems.
- Double drum traction winches introduce more bending cycles than a single drum winch. However, traction heads are properly grooved to support the cable whereas on single drum winches the cable is supported by the cables beneath it. In this configuration, the support geometry is not as good.
- A problem with single drum winches is that tension surges are dissipated over a shorter length than with traction winch installations. This is particularly critical where proper spooling of the cable has not been provided since the cinching action of the tension surge can cause cables to force themselves between lower layers. This is extremely detrimental to cable life.
- Torque balancing is required to prevent loops and kinks from forming in the cable. Therefore, although torque balanced cable does not appear to be a requirement for deploying the Sea-Marc vehicle, this is not necessarily the case with all deep tow vehicles.
- Bending cycles and sheave size are inter-related parameters and Tension Member Technology have fairly refined information on many types of cable construction. The fatigue life of cable varies considerably and among the many factors that affect fatigue life are the helix angle of the armouring, the percentage space between two wires on the same layer, and the metallurgical properties of the wires. By way of illustration, Tension Member Technology have recently tested two electro/mechanical cables of identical construction with the exception of the helix angle of the wires and obtained quite different fatigue lives.

Blake Wire and Cable Corporation, Terrance, California - Mr. Bill Tell of Blake Wire and Cable Corporation was contacted on December 1, 1981 and he provided the following information:

- Coaxial cable normally fails due to work hardening of the conductor, and when designing cables, it is important to make sure that when the cable is loaded, it is the armour that takes the load, not the copper conductor. This is more difficult than it seems because the copper conductor is closer to the cable length than the armour wires which are 3 to 5% longer due to the cable construction. Consequently unless special arrangements are made the copper conductor can be overloaded. The Blake Wire and Cable Corporation recommend that the copper conductors be spirally wound around a nylon filament in order to ensure that the conductor is sufficiently long so as not to carry any of the cable load.
- For land applications it is normal to use a polyethylene coating over the copper conductor, but in marine applications, polypropylene is preferred. Polypropylene has greater stiffness, a higher resistance to cold flow, a high tensile strength, and is more suitable for high pressure applications.
- The Blake Wire and Cable Corporation were unable to provide any conclusive information on the problems associated with storage of electro/mechanical cable under high tension, however, they consider that storage under high tension is probably undesirable and mention that they normally spool cable at around 500 lbs. tension for shipment.

Vector Cables, Houston, Texas - Mr. Barry Campbeilh of Vector Cables was contacted on December 2, 1981, and he provided the following information:

- Although unable to quantify the problems associated with storage of cable under high tension, Mr. Campbeilh indicated that the failure mechanism would be associated with armour piercing the jacket and eventually pinching the conductor.

3.0 TECHNICAL CONSIDERATIONS

3.1 Summary Requirements

The operating requirements associated with the deployment of the Sea-Marc bottom profiling system are summarized below:

Operating depth 20,000 ft. maximum
Cable length 30,000 ft.
Cable diameter 0.68"
Line speed - maximum 300 ft./min.
 - minimum 3 ft./min.
Line pull - normal operation 15,000 lbs.
 at 200 ft./min.
 - maximum 30,000 lbs.
Tension limiting - Yes
Motion compensation - No
A Frame or Towing Crane - Yes
Slip ring assembly - Yes

3.2 Winch Selection Criteria

Winch selection is primarily governed by three considerations:

- the operating requirements of the Sea-Marc system as identified in Section 3.1;
- the characteristics of the vessel or vessels upon which the system is to be installed; and
- the desired operating life of the winch and the various system components.

Accepting that both the operating requirements of the system to be deployed and the characteristics of the BIO ships are essentially fixed the governing consideration becomes that of operating life.

With regards to operating life the key element is the electro/mechanical cable used to deploy the Sea-Marc and any winch system must be compatible with the requirements of the electro/mechanical cable or vice versa.

Electro/mechanical cable life is governed by:

- the number of bending cycles to which the cable is subjected;

- the bend radius of the winch and the various sheaves that comprise the total handling system;
- the extent and magnitude of tension cycling to which the cable is subjected; and
- whether or not the cable is stored under tension.

Generally, it can be stated that the less the number of bending cycles the better; the greater the bend radius the better; and the less the extent and magnitude of tension cycling the better.

It is difficult to say with any degree of certainty whether storage under tension is desirable or not, but based on the information we have collected we are of the opinion that providing the storage tension does not exceed 50% of the cable breaking strength it is not detrimental, and, in the case of electro/mechanical cable, possibly advantageous.

3.3 Single Drum Versus Traction Winch

The following is a comparison of the merits of single drum and traction winches as they relate to the deployment of the Sea-Marc system. That is, the comparison is only applicable to this application and other applications should be the subject of an independent assessment.

- Bending Cycles - Typically a single drum winch introduces considerably fewer bending cycles than a traction winch of similar capacity. This has a direct bearing on cable life which in a comparative, if not an absolute sense, can be quantified. The number of bending cycles should be evaluated on the basis of the complete system, that is, the winch and deck layout, rather than the winch alone.
- Tension Cycling - With a single drum system the cable is stored at tensions that reflect the history of the deployment. Since, other than transient effects, the tension history is essentially constant, the cable is not subjected to a wide range of operating tension. This is advantageous when considering cable life, and, furthermore, storage under tension is recommended for electro/mechanical cables within certain limits. It is also recommended that when the cable is first put on the drum it is stored at values of tension that approximate the tension history that will be experienced in service. On traction winches the cable is continuously subjected to

large changes in tension between the load and storage side of the traction heads.

- Simplicity of Operation - A single drum winch is far easier to understand and operate than an equivalent traction winch. This is an extremely important consideration where inexperienced operators are utilized, and this situation may, on occasion exist at the Bedford Institute of Oceanography.
- Maintenance - The hydraulics associated with a single drum winch are far less complex than an equivalent traction winch and this implies greater reliability and simpler maintenance and repair requirements. In the absence of hydraulic expertise in the immediate area this is an important factor.
- Size and Weight - A single drum winch is both smaller and involves less weight than a traction unit of equivalent capacity. This offers obvious advantages for most ship board installations.
- Low Tension Storage - The following benefits are frequently associated with low tension storage:
 - The cable is stored at low tension and this is beneficial to cable life. In fact, in the case of electro/mechanical cable, the reverse may be true.
 - The use of low tension storage avoids the problems of drum and flange design associated with single drum winches. While this is certainly true, it is a design problem rather than an inherent failing of single drum winches. Therefore, providing a suitable drum can be designed, and we believe it can, this argument cannot really be used to support the selection of a traction winch.
- Constant Line Pull - Traction winch systems provide a constant line pull regardless of the length of cable deployed whereas with single drum winches the line pull varies with the takeoff diameter. This is a desirable feature of traction winches and, in some applications, this feature is sufficient to dictate the use of a traction winch. In the case of the Sea-Marc where maximum line pull is associated with the maximum length of cable deployed, this is not a governing criteria.
- Cable Support - With a traction winch the cable is supported in a properly shaped groove while under high

tension whereas with a single drum unit the cable is supported by the layers of cable beneath it. While support in a properly shaped groove is intuitively the best, we have been unable to make a quantitative comparison with the layered cable support. Nevertheless, it is evident that unless proper spooling and hence proper cable support is achieved on a single drum winch, cable life will be drastically reduced.

- Flexibility - Traction winch systems offer greater overall flexibility than single drum winches because interchangeable traction heads can be purchased for various cable sizes and types and used with lightly constructed storage drums. While this is certainly true in many applications, particularly those involving synthetic ropes, electro/mechanical cable requires proper spooling even at low tension. Therefore even the storage drum will require proper spooling equipment.
- Flexibility of Installation - Traction winches offer greater flexibility of installation than single drum winches because the storage winch can be separated from the traction heads. This permits the storage winch to be installed below deck or in other advantageous locations. Some of this flexibility has been negated by safety requirements on the BIO vessels which require that even cable on the low tension side of the traction heads be contained in cable trays.
- Tension Surges - It has been suggested that traction winch systems are less susceptible to tension surges than single drum winches because slippage can take place over the traction heads. In the case of single drum winches there is no "slack" in the system and the surge must be dissipated over a relatively short cable length. Unless the cable is properly spooled, this can cause cinching of the cable between the lower cable layers. This is particularly detrimental to cable life.
- Slippage - Traction winches rely on friction between the traction heads and the cable to carry the load. With electro/mechanical cables which are lubricated to prevent corrosion, the lubrication can be squeezed out of the cable thereby reducing the friction and causing slippage. When the cable stops slipping this can result in impact loads. To prevent slippage it is necessary to carefully control the storage winch tension and this can introduce control problems.

- Control - Where rapid response is required, traction winches are better because the system does not have to overcome the high inertia of the cable storage drum. However, it has been suggested that low speed control is difficult to obtain with traction winches. We have yet to establish the validity of this latter statement.
- Cost - Single drum winches are significantly less expensive than traction winches, perhaps by a factor of two or three. Maintenance costs are also significantly less because of the lesser complexity.

3.4 Discussion

While the operating requirements associated with deployment of the Sea-Marc were relatively straightforward to identify, the selection of the most appropriate type of winch was quite difficult.

This is because among the various users there are two, possibly three, schools of thought as to the most appropriate type of winch. The alternatives being a single drum winch, a multi-pass traction winch and a V-grooved traction winch.

While the choice of winch type varies, the criteria used to determine winch suitability are consistent, that is, cable life and operating conditions. Cable life is particularly significant because of the high direct cost (\$100,000 for 30,000 feet) associated with this item, and also the high indirect cost associated with failure of the cable. Operating conditions during deployment, use and recovery are also a major consideration in the selection of the most appropriate winch and handling system.

Proponents of single drum winches emphasize system simplicity, fewer bending cycles, and cost as the desirable features of single drum winches, while proponents of traction winches emphasize system response, system flexibility, low tension storage and the implications of this on drum design, and the fact that while under high tension the cable is contained in properly shaped grooves which minimize cable wear. As is frequently the case when disagreements arise, there are merits to both arguments.

Although both single drum and traction winch systems offer workable solutions, we believe a single drum winch is the winch is the most appropriate for the deployment of the Sea-Marc. Factors that influenced this conclusion include:

- generally the technical evaluation favours single drum winches rather than traction winches;
- the relative simplicity of single drum winches is beneficial under the Bedford Institute's mode of operation;
- single drum winches are significantly less expensive than traction winches; and
- single drum winches are smaller and lighter and therefore more portable than equivalent traction winches.

This assessment agrees with the recommendations of the two organizations most familiar with the use of deep tow vehicles - Lamont Doherty Geological Observatory and Scripps Oceanographic Institution. However, it is important to realize that neither of these organizations presently utilize a single drum winch and to date have deployed their deep tow systems using traction winches. On a more positive note, a particularly successful installation is the large single drum winch on the Deep Sea Ventures' vessel R.V. Prospector. This installation has been operating for 12 years with few, if any, problems or damage to the electro/mechanical cable.

It is also reported that following an extensive evaluation of various deep tow systems, the Japanese (Jamtech) selected a single drum winch for their deep tow program.

3.5 Recommended Winch

The recommended winch for the deployment of the Sea-Marc system is a single drum winch generally meeting the following design requirements.

- Storage capacity - 30,000 ft. of 0.68" dia. cable.
- Drum and flange design to be compatible with cable storage starting at 20,000 lbs. tension on bare drum decreasing linearly to 10,000 lbs. tension with 30,000 ft. of cable on the drum.
- Drum core diameter - 34" minimum
- Rated line pull bare drum - 20,000 lbs. at 150 ft./min.
- Rated line pull, full drum - 10,000 lbs. at 300 ft./min.
- Maximum line pull, bare drum - 30,000 lbs.

- Maximum line speed, full drum - 300 ft./min.
- Speed control - variable from 3 ft./min to 300 ft./min.
- Drive system electro/hydraulic
or diesel hydraulic
- Disc brake system
- Fail safe braking
- Lebus grooving
- Lebus fleet angle compensator with positive sheave control.
- Compensator sheave diameter - 40" minimum
- Maximum width of unit - 8' 6"
- Maximum height of unit - 8' 6"
- Maximum length of unit - minimum practical
- Readily accessible slip ring assembly.

3.6 Ancillary Equipment

Motion Compensation

There are two basic types of motion compensation system, active and passive. An active system monitors either vehicle or ship motion and by the use of sophisticated control systems attempts to maximize vehicle stability. This type of system is both complex and expensive. A passive system is basically a constant tension device which utilizes a system of sheaves to take in or pay out cable and thereby minimize tension surges. Indirectly, this system also provides a degree of motion compensation. This system is not necessarily complex and at its most basic, not particularly expensive. It does, however, introduce more bending cycles into the tow cable.

From discussion with the various users, an active motion compensation system is neither desirable nor necessary to deploy the Sea-Marc vehicle. Whether a passive or tension compensating device is required appears to be related to the cost and difficulty associated with the particular installation. Generally, we believe that such a system offers some worthwhile advantages, but further investigation of this

item is warranted. The experience gained on the Bedford Institute's upcoming cruise (April 1982) should provide the answer to this question.

The reason the Sea-Marc does not require an active motion compensation system is that the vehicle is decoupled from the tow cable by a large depressor and 300 ft. of neutrally buoyant line.

Towing Crane or A Frame

The optimum point for towing deep tow vehicles is from the stern of the ship and towing is normally accomplished using some form of towing crane or A frame. Towing from the stern greatly enhances ship maneuverability and this is extremely desirable with a vehicle towing 3 or more miles behind the ship. A towing crane of the type developed by Scripps is more desirable than an A frame primarily because it further improves ship maneuverability. Further investigation of this item is required before a final recommendation can be made, and, in the interim, an A frame provides an acceptable solution.

Slip Rings

Some form of mercury filled slip ring assembly is desirable for the deployment of the Sea-Marc. This is because the vehicle is continually being raised or lowered as the bottom topography changes and continuity of electrical signal is contingent upon the use of good quality slip rings.

3.7 Other Considerations

Cable Life - Electro/mechanical cables are engineered systems in their own right and proper cable specification is essential to maximize cable life. This is an extremely important consideration with cables costing in the order of \$100,000.

Proper cable selection can be best ensured by providing potential cable manufacturers with full details of the system layout and proposed methods of operation. Upon receipt of cable designs from the manufacturers, it will, with specialist assistance, be possible to evaluate them and make the most appropriate selection.

Another major factor in maximizing cable life is proper maintenance of the cable. For example, after each cruise the cable should be properly washed, dried and lubricated before storage in order to prevent rapid corrosion and deterioration. A further step is maintaining a detailed

record of cable use including length of cable deployed, operating conditions, range of operating tension, estimated bending cycles, visible damage, etc. This information can be used to establish maintenance procedures such as reversing the cable, replacing heavily worn sections, and returning to the manufacturer for refurbishing.

3.8 Piston Coring and Rock Core Drilling

Piston Coring

The recommended type of single drum winch has the ability to take piston cores, and while the tension history associated with piston coring is quite different from deep towing, the drum design will be adequate for this application. However, it would not be advisable to use the electro-mechanical deep tow cable for piston coring. Two options exist:

- (1) To specify a winch drum with bolt on Lebus grooving and change cables as required.
- (2) To specify interchangeable winch drums and change both drum and cable as required.

By utilizing interchangeable winch drums, the drum design could be tailored to meet the specific requirement, but we do not see this as a significant advantage. Furthermore, it might, unless the drums were visibly different, result in confusion.

Interchangeable drums do offer the advantage of more rapid turnaround from one system to another.

The recommended approach is to provide for both options by specifying bolt on Lebus grooving and readily interchangeable winch drums.

It should be noted that when changing cables, it will also be necessary to ensure that all sheaves are of the appropriate diameter and sized to suit the particular cable.

Rock Core Drilling

The recommended type of single drum winch has the ability to carry out rock core drilling, and while the tension history associated with rock core drilling is quite different from deep towing, the drum design will be adequate for this application. The electro/mechanical cable may also be compatible strength-wise, but there is some question as to whether the electrical characteristics are suitable for

transmitting television signals - television cameras are sometimes used with the rock core drill.

As with piston coring, the requirement for rock core drilling is provided by bolt on Lebus grooving and readily interchangeable winch drums.

3.9 Traction Winch Alternative

While we have concluded that a single drum winch is the most appropriate for the deployment of the Sea-Marc, to date most deep tow systems, including the Sea-Marc, have been deployed using traction winches.

Based on our evaluation the most suitable type of traction winch is a V-groove traction winch of the type used by International Submarine Technology Ltd. (IST), the designers of the Sea-Marc vehicle. The primary advantage of this type of traction winch over a conventional multi-pass traction winch is that far fewer bending cycles are introduced into the cable.

4.0 EVALUATION OF BIO VESSELS

4.1 CSS Hudson

The CSS Hudson is the most logical BIO vessel to carry the proposed towing winch.

While sufficient deck space is available on both the fore-deck and afterdeck of the Hudson, ship maneuverability considerations dictate that the towing winch be installed on the stern. A further consideration favouring an afterdeck installation is that the existing Pengo winch on the fore-deck already provides the ability to undertake piston coring, rock core drilling, and to a limited extent, deep towing.

A disadvantage of installing the winch on the afterdeck is that a portion of the helicopter deck will need to be made removable.

The afterdeck will require few, if any, structural modifications to carry the winch and associated cable loads. Nevertheless a detailed evaluation will be required when the final winch selection has been made and attachment details are available.

Overall vessel stability will not be a problem with the winch on the afterdeck, but as with the structural consider-

ations, further evaluation should be conducted following final winch selection.

The existing 'A' frame on the stern of Hudson is designed to carry a distributed load of 8,900 lbs. at full extension with a safety factor of between 4.0 and 5.0.

A preliminary investigation indicates that by restricting the 'A' frame to its minimum extended height and applying the load at the centre lifting point a safety factor of 2.0 is achievable at an operating load of 15,000 lbs. This safety factor assumes that the load is applied normal to the 'A' frame (the optimum direction) and makes no allowance for side loads that would be developed as the vessel turned. As such, the safety factor is well below that normally recommended for ship board installations. Obviously, the 'A' frame is of insufficient strength to develop the 30,000 lb. line pull required in an emergency situation.

In a general sense, the weaknesses of the existing 'A' frame are the cross member, the hydraulic cylinders, and the inability of the frame to take side loads. The legs of the frame appear adequate but further analysis is required of the connection details.

While as demonstrated above the 'A' frame is generally undersized, it may, as an interim measure, be possible to accommodate the side loads and relieve the loads on the hydraulic cylinders by the addition of suitable stays or guy cables. The cross member could be either strengthened or replaced. Modifications of this type may be appropriate during the initial training cruises with the deep tow system, but are not a long term solution.

4.2 CSS Baffin

There is little, if any, readily available space on the CSS Baffin for the installation of a towing winch.

The majority of the deck space at the bow is allocated to survey launches and other equipment, and at the stern space is severely restricted by the helicopter deck and other equipment.

Vessel stability would also be a problem unless other equipment, for example, the launches, were excluded from cruises involving deep towing.

4.3 CSS Dawson

There is no suitable space for a towing winch on the stern of Dawson and therefore we consider it unsuitable for the deployment of a deep tow vehicle.

Vessel stability would also be a major problem with a winch of this size.

5.0 CONCLUSIONS

A single drum winch is the most suitable type of winch for deploying the Sea Mark deep tow vehicle because it is:

- Less complex
- Simpler to operate
- Smaller and lighter
- Less expensive
- Better suited technically
- Favoured by experienced users of Sea Marc

The winch should have the following basic features:

- An electro/hydraulic or diesel/hydraulic drive
- A winch drum of 34" minimum diameter and a capacity of 30,000 ft. of 0.68" electro/mechanical cable.
- Bolt on Lebus grooving.
- Lebus spooling.
- A Lebus fleet angle compensator with a compensator sheave of 40" minimum diameter and positive sheave control.
- The ability to accept interchangeable winch drums.
- A tension limiting device incorporated.
- A nominal rating of 20,000 lbs. line pull at 150 ft./min. at the bare drum.
- A maximum line pull of 30,000 lbs. at the bare drum. (This line pull being associated with emergency recovery only - line speed is not a criteria.)
- A maximum line speed of 300 ft./min. at the full drum.
- A minimum controllable line speed of 3 ft./min.

Tension measurement and line metering should be independent of the winch, preferably at the stern sheave.

The 0.68" cable should be specified to suit the winch installation and deck layout. The actual selection should be made with the assistance of a technical expert.

The towing winch should be installed on the stern of the vessel to provide the necessary ship maneuverability.

The CSS Hudson is the most appropriate vessel and the winch should be installed on the stern. The 'A' frame will require modification and ultimately replacement.

The CSS Baffin has both space and stability restrictions.

The CSS Dawson is unsuitable.

APPENDIX 1

ADDRESSES OF USERS, WINCH MANUFACTURERS,

AND CABLE MANUFACTURERS

WINCH MANUFACTURERS

Canadian Manufacturers

- 1) Do-Tan Manufacturing Limited
15 Hatt St.
Dundas, Ont.
L9H 2G1

Contact: Mr. R. Elms

Phone: 416-628-2241

Telex: 061-8852

- 2) Fathom Oceanology Ltd.
863 Rangeview Rd.
Port Credit Ont.

Contact: A. McLerie
Technical Sales Contracts Administrator

Phone: 416-274-1551

Telex: 06-960226

- 3) John T. Hepburn Ltd.
Mechanical Division
914 Dupont St.
Toronto, Ont.
M6H 1Z2

Contact: Mr. E. Pfieler & Mr. R. Ballentyne

Phone: 416-671-2200

Telex: 06-968793

- 4) MSE Engineering Systems Ltd. * 265 Canartic Dr.
Downsview, Ont.
M3J 2M7

Contact: Mr. T. Cooper
Technical Representative

Phone: 416-661-5646

Telex: 065-23982

* MSE Engineering Systems Ltd. are agents for:

Sea Mac Marine Projects
8702 Pagewood, Houston
Texas, USA
77063

Contact: G. Hower

Phone: 713-784-5454

Telex: 762285

- 5) Techwest Enterprises Ltd.
3650 Wesbrook Mall
Vancouver, B.C.
V6S 2L2

Contact: W.D.R. Thomas, Manager
Marine and Mechanical Engineering Group

Phone: 604-224-1113

Telex: 04-507748

- 6) Timberland Equipment Ltd.
P.O. Box 490
Woodstock, Ont.
N4S 7Z2

Contact: Mr. L. Clark
Product Co-ordinator

Phone: 519-537-6262

Telex: 064-74133

- 7) Wilson Machine Company
2299 Lapierre St.
Lasalle, Quebec
H8W 1B7

Contact: Mr. Arnold

Phone: 514-365-4101

Telex: 055-66265

USERS

- 1) Deep Sea Ventures
P.O. Box 486
Gloucester Point
Virginia 23062

Contact: Mr. R. Kaufman

Phone: 804-642-2121

Telex: 828398

- 2) International Submarine Technology Ltd.
2733-152 Ave.
North East Redmond, Washington
98052

Contact: Dr. J. Kosolas

Phone: 206-883-6171

Telex: 04-353554

- 3) Lamont Doherty Geological Observatory
Columbia University, Palisades
New York 10964

Contact: Dr. W. Ryan & Mr. D. Chayes

Phone: 914-359-2900

Telex: -

- 4) Marine Physical Laboratory of
the Scripps Institution of Oceanography
San Diego, California
82132

Contact: Mr. D.E. Boegeman
Engineering Section Head
Deep Tow Project

Phone: 714-294-3650

Telex: -

5) Racal Decca Survey Incorporated
P.O. Box 22397
Houston, Texas
77027

Contact: Mr. R. Hoff & Mr. R. Haas

Phone: 713-783-8220

Telex: 0775194

6) Sound Ocean Systems Inc.
4326 150th Ave.
Bellevue, Washington
98006

Contact: Mr. T. Brockett

Phone: 206-746-3926

Telex: -

7) Westinghouse Electric Corporation
Oceanic Division
P.O. Box 1488
Annapolis
Maryland, USA
21404

Contact: Mr. A. Haury

Phone: 301-765-5477

Telex: -

8) Woods Hole Oceanographic Institution
Woods Hole
Massachusetts, 02543

Contact: Captain R. Dinsmore

Phone: 617-548-1400

Telex: 951679

U.S. Manufacturers

- 1) Lebus International Inc.
P.O. Box 2352
Longview, Texas
75606

Contact: Mr. L. Green
Winch Engineer

Phone: 214-758-5521

Telex: 735429

* At the present time Lebus do not manufacture complete winches.

- 2) Markey Machinery Co. Inc.
79 South Horton St.
P.O. Box 24788
Seattle, Washington
98124

Contact: Mr. M.J. Markey

Phone: 206-622-4697

Telex: -

- 3) Tension Stringing Equipment Inc.
Route 4, Box 124F
Shreveport, Louisiana
77107

Contact: Mr. B. Crawford

Phone: 318-929-2368

Telex: 507441

- 4) Smatco
P.O. Box 4036
Houma, Louisiana
USA 70361

Contact: -

Phone: 504-868-0630

Telex: 58-7311

CABLE MANUFACTURERS

- 1) Blake Wire & Cable Corp.
19505 Pacific Gateway Drive
Torrance, California

Contact: Mr. W. Tell

Phone: 213-515-0561

Telex: --

- 2) Rochester Corp.
P.O. Box 312
Culpeper, Virginia
22701

Contact: Mr. A. Berian
Product Manager

Phone: 703-825-2111

TWX: 710-839-3439

- 3) South Bay Cable Division
P.O. Box 67
Idyllwild, California
92349

Contact: Mr. T. Stannitz

Phone: 714-659-2183

Telex: -

- 4) Vector Cable Co.
555 Industrial Rd.
Sugarland, Texas
77478

Contact: Mr. W. Savage
Sales Development Engineer

Phone: 713-491-9196

Telex: 910-880-4891

CABLE CONSULTANTS

1) Tension Member Technology
15161 Golden West Circle
Westminster, California
92683

Contact: Mr. P. Gibson

Phone: 714-898-5641

Telex: -

APPENDIX 2

WINCH PERFORMANCE SPECIFICATION

PERFORMANCE SPECIFICATION

FOR A

DEEP TOWING WINCH

1.0 ELECTRO-HYDRAULIC POWERED WINCH

1.1 Purpose

The purpose of the winch is to deploy, operate, and recover a deep tow vehicle at water depths up to 20,000 ft.

1.2 Operating Environment

The winch is required to operate in the marine environment. Under adverse weather conditions it will be subject to immersion in sea water and associated impact loadings, and shock loadings associated with violent ship motions. In northern waters it will be subject both to ice build up and the abuse of seamen trying to remove the ice.

1.3 General

The winch shall be capable of stopping, holding and restarting under the specified loading conditions and speeds. Stops and starts shall be smooth in either direction of drum rotation.

The winch shall be of robust construction and hydraulic lines and fittings liable to damage shall be protected by guard covers.

1.4 Line Speed and Line Pull

- Bare drum 20,000 lbs. at 150 FPM
- Full drum 10,000 lbs. at 300 FPM
- Maximum line speed (full drum) 300 FPM
- Minimum controllable line speed 10 FPM
- Maximum line pull, bare drum 30,000 lbs.
(This line pull is associated with emergency recovery only, that is, if towed body stuck on bottom - line speed is not a criteria).

1.5 Tension Limiting

An incremental tension limiting device shall be incorporated to enable the operator to preset the maximum developed tension at either 15,000; 17,500; or 20,000 lbs. An override shall be provided to accommodate the emergency requirement to develop 30,000 lbs. line pull.

1.6 Winch Drum

- Capacity - 30,000 ft. of 0.68" diameter electro mechanical cable
- The design shall permit the winch drum (complete with cable) to be readily interchangeable.
- Bolt on Lebus grooving to be provided for 0.68" diameter cable.
- Minimum drum diameter 32".
- Drum strength to be compatible with requirements of Lebus spooling and storage tensions varying from 20,000 lbs. on the bare drum to 10,000 lbs. on the full drum.

1.7 Spooling

The horizontal distance between the centreline of the winch drum and the centre of the sheave where the cable leaves the ship shall be minimized. The attached sketch shows the relationship between the stern sheave and two possible winch locations on the CSS Hudson.

A Lebus fleet angle compensator with positive sheave control shall be provided.

The minimum compensator sheave diameter shall be 40".

The positive sheave control mechanism shall be adjustable to accommodate different wire sizes.

1.8 General Dimensions of Winch Unit

- Maximum overall width 8'-6"
- Maximum overall height 8'-6"
- Maximum overall length minimum practical

REPRESENTATIVE LAYOUT(S)

CSS HUDSON

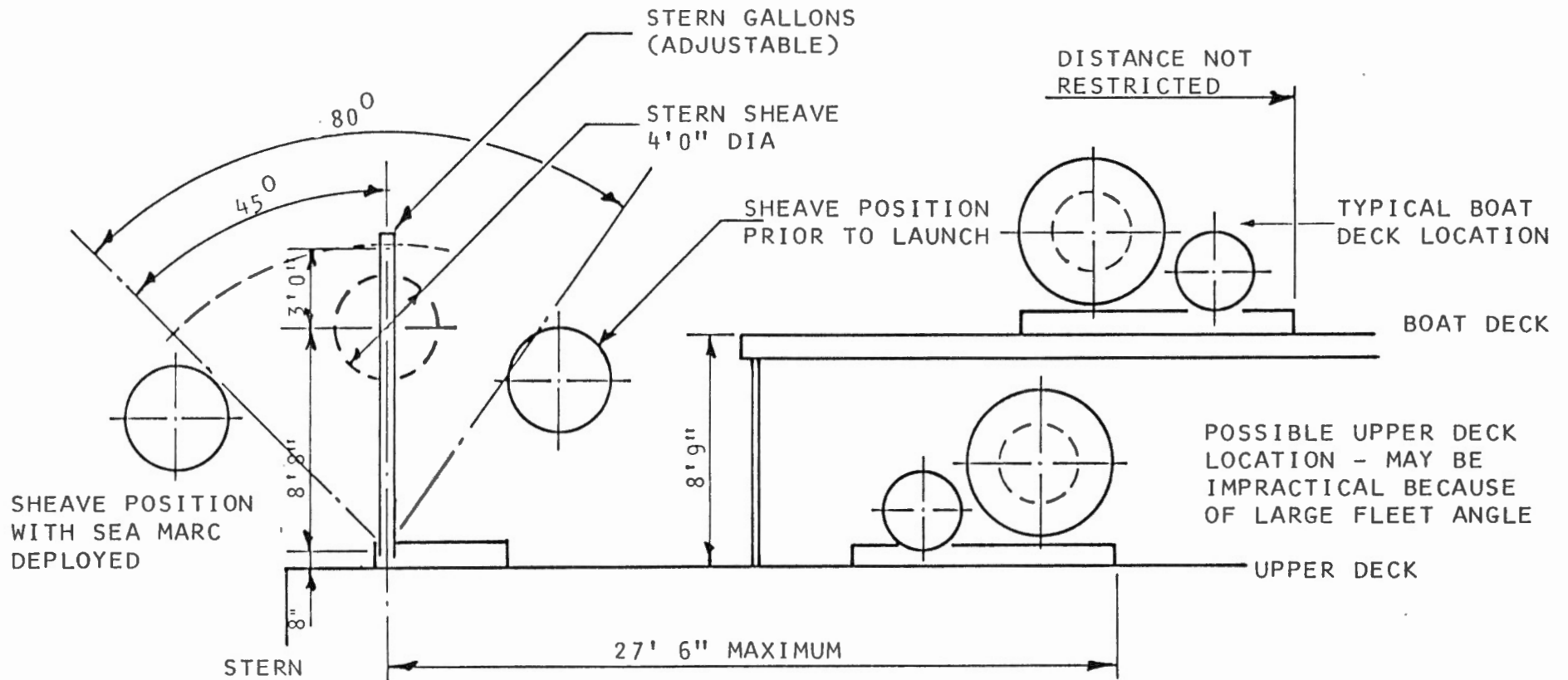

APPROXIMATE DIMENSIONS ONLY

The hydraulic power pack shall be a separate unit connected to the winch by flexible hose. As such, it is not included in the above dimensions.

With the exception of the hydraulic power pack, all components shall be mounted on a rigidly constructed mild steel frame with lifting lugs for installation and removal.

1.9 Slip Rings

Slip rings shall be installed by others at a later date. Therefore, the winch drum shaft shall be hollow and there shall be unrestricted access to one end of the shaft. The access hole shall be a minimum of 1½" diameter.

1.10 Line Metering and Tension Recording Equipment

Not required.

1.11 Operator's Controls

The operator's controls shall provide directional control, speed control and brake control. Indicator lights and a hydraulic system pressure gauge shall be provided to indicate the condition of the equipment.

The winch controls shall be so arranged that in the event the winch operator is suddenly incapacitated the winch drum shall cease rotation and the main winch brake shall be applied.

1.12 Remote Control

The facility to override the operator's controls and main winch brake and operate the winch from a remote (laboratory) location shall be provided.

The remote control option is required to accommodate prolonged (several days) operation at slow speed and is associated with the need to maintain the deep tow vehicle at a constant height above a gradually sloping sea bed. The ability to operate at high speed under remote control is not required.

1.13 Power Source

The winch shall be powered by an electro-hydraulic drive with electric power provided by the ship's

electric system. The pump must be unloaded for starting to permit electric motor starting with reduced voltage supply and a reduced voltage starter shall be supplied.

The ship's electric system is 440 VAC, 3 phase, 60Hz.

The hydraulic power unit shall be mounted on a separate frame from the winch assembly and connected to it by flexible hydraulic hoses 40 ft. in length. The frame shall be rigidly constructed and fitted with lifting lugs.

The hydraulic power unit shall be suitable for installation and operation on an exposed deck.

1.14 Hydraulic Motor

The hydraulic motor shall be installed on the main winch frame and connected to the hydraulic power unit by flexible hydraulic hose.

Hydraulic ports shall be marked to indicate related direction of rotation.

1.15 Hydraulic System

The maximum working pressure associated with the maximum line pull of 30,000 lbs. shall not exceed 3,000 psi.

The working pressure associated with a line pull of 20,000 lbs. shall not exceed 2,000 psi.

All hydraulic components shall be rated for continuous operation at 3,000 psi.

The hydraulic system shall be rated for continuous operation at a line pull of 20,000 lbs. and a line speed of 150 FPM.

The hydraulic system shall be designed to operate for a minimum period of 1/2 hr. at a line pull of 30,000 lbs.

The hydraulic system shall accommodate a range of ambient temperature from -20°F to 120°F.

The hydraulic system and components shall be designed to operate on fluid conforming to CGSB Specification 3-GP-59 Grade 2.

The hydraulic system shall incorporate a fail safe braking arrangement.

Provision shall be made to prevent damage to the system or components in the event of an overload condition.

Provision shall be made in all components for bleeding and venting entrapped air.

Adequate filtration shall be provided.

Preference will be given to a closed loop system.

1.16 System Cooling

In the event that system generated heat cannot be dissipated in the reservoir at a rate consistent with the most severe operational mode, a sea water/hydraulic fluid heat exchanger shall be supplied as part of the system.

1.17 System Piping

Inter-connecting piping shall be tested at 50% over the maximum working pressure, that is, 4,500 psi for a 3,000 psi system.

1.18 Reservoir

The reservoir shall be a fabricated structure designed to minimize contamination of the system by corrosion products and shall be furnished complete with fluid level indicators, low level alarm, clean out doors, pump suction filters or strainers, filter protected filling arrangement, conveniently located drain facilities and an air breather arrangement. Internal surfaces of the reservoir shall not be coated with any "permanent" type corrosion preventative compound. Internal baffles shall be fitted in the reservoir (roll $\pm 25^\circ$; pitch $\pm 10^\circ$) to minimize the effect of ship motion in a seaway.

1.19 Braking

The main winch brake, shall be independent of the fail safe braking arrangement incorporated into the hydraulic system and shall be capable of stopping and holding 150% of the maximum rated line pull.

1.20 Fail Safe Systems

Fail safe systems shall be provided to prevent the winch getting out of control for any reason including failure of hydraulic components, electric power failure or diesel (if appropriate) failure.

1.21 Moving Parts

All moving parts shall be provided with suitable guards to ensure safe operation.

1.22 Shock Loading

The winch assembly, power unit and all equipment shall be capable of withstanding a continuous shock loading of 0.5 g in both the horizontal and vertical directions.

1.23 Painting

All exposed steel surfaces shall be coated with a zinc rich paint and sealer after cleaning and sand blasting to a near white metal blast.

1.24 Nuts, Bolts, Washers, Drive Chains

Where appropriate nuts, bolts, washers and drive chains will be a suitable grade of stainless steel.

1.25 Drip Tray

A drip tray shall be provided beneath the winch drum and spooling mechanism(s) to prevent lubrication squeezed from the cable getting on to the deck. Each corner of the drip tray shall be fitted with a 1½" NPT female fitting (and plug) for attachment of drainage hose.

2.0 DESIGN OPTIONS

2.1 Diesel Hydraulic Power Unit

The provision of a diesel hydraulic power unit, and all associated controls and equipment to enable the deep towing winch to function independently of ship service power. The diesel to be capable of absorbing the energy generated during deployment of the vehicle.

The diesel hydraulic power unit to be mounted on a separate frame to the main winch assembly and con-

ected to the hydraulic motor by flexible hydraulic hoses. The frame to be fitted with suitable lifting lugs and the entire assembly to be suitable for installation and operation on an exposed deck.

3.0 NOTES REGARDING REQUEST FOR PROPOSAL

The 'Request for Proposal' for the manufacture and supply of the deep towing winch should advise bidders of the following requirements:

3.1 Engineering Data

The requirement for sufficient technical information at the proposal stage to permit assessment in terms of the performance requirements of the specification. The following is considered the minimum engineering data to allow a proper evaluation: (Bidders should be allowed to exercise judgement in this area and be encouraged to include additional information which will facilitate assessment of proposals.)

- (a) Description of the construction and operation of the winch with an outline drawing showing overall dimensions, location of securing bolt holes, and hydraulic connection points.
- (b) Itemized list of all major components.
- (c) Sectional arrangement drawing depicting the drive mechanism.
- (d) Approximate weight of equipment.
- (e) Efficiency at 50% and 100% of specified duty requirement.
- (f) Performance curves.
- (g) Outline of test facilities owned or available to bidder and suitable for conducting tests in accordance with requirements of the governing specification.
- (h) Schematic electrical and hydraulic system diagrams.

3.2 Financial Data

The requirement for complete financial data at the proposal stage identifying the following:

- (a) A firm price for the supply of an electro-hydraulic powered deep towing winch in accordance with the requirements of the performance specification.
- (b) A firm price for the supply of a diesel hydraulic power unit to enable the winch to function independently of ship service power.
- (c) A firm price for a spare winch drum and matching compensator sheave.
- (d) A firm price for the supply of four (4) sets of operating and maintenance manuals.
- (e) A firm price for the supply of one (1) reproducible set of assembly drawings.
- (f) A firm price for recommended spare parts on the following basis:
- Any 90 day period on board ship.
 - Sufficient spares to support the equipment for a 5 year period.
- (g) A firm per diem rate per man for field engineering services for the 12 month period following acceptance of the equipment.

3.3 Design Review

The requirement for the contractor to submit both preliminary and final design drawings for review and approval of the client prior to manufacture of the unit.

3.4 Tests

The requirement for the contractor to conduct shop tests which adequately demonstrate that the equipment meets the performance criteria in all respects.

3.5 Manuals

The requirement for the contractor to supply operating and maintenance manuals containing the following information:

- detail drawings of the winch assembly, drum assembly and all sub-assemblies.

- full technical data on all component parts.
- maintenance schedule.
- installation instructions.
- recommended spare part list on the following basis:
 - (a) Any 90 day period on board ship.
 - (b) Spares sufficient to support the equipment supplied for a period of 5 years.

3.6 Field Engineering Services

The requirement for the contractor to supply field engineering services during installation, testing, tuning or trials, as well as such other inspections as may be required from time to time. The contractor to provide per diem rates per man with travel and living at cost. These services to be provided under a separate contract.



APPENDIX 3

CABLE PERFORMANCE SPECIFICATION

CABLE PERFORMANCE SPECIFICATION
FOR A

DEEP TOWING WINCH CABLE

o Purpose

The purpose of the winch is to deploy, operate, and recover a deep tow vehicle at water depths up to 20,000 ft.

o System Description

The cable will be stored on a single drum winch of the type described in the accompanying information. The winch will employ a Lebus grooved drum, and a Lebus fleet angle compensator with positive sheave control.

o Basic Cable Specification

An electro/mechanical cable to U.S. Military Specification RG8/U and similar to that provided to Scripps Institution of Oceanography, San Diego, California, U.S.A. except where modifications can be made to enable the cable to perform more satisfactorily with the specified handling and deployment system. The Scripps handling system utilizes a traction winch with low tension storage, whereas the specified system utilizes a single drum winch with high tension storage.

o Cable Length

30,000 ft.

o Cable Diameter

0.68" diameter.

o Required Supporting Information

- Maximum storage tension
- Recommended maintenance requirements
- Details of cable construction
- Estimated fatigue life - bending cycles
- Dimensional tolerances for cable

APPENDIX 4

TERMS OF REFERENCE

TOWING WINCH ACQUISITION AND INSTALLATION STUDY

To carry out an investigation of the type, performance and feasibility of installing a winch on BIO ships (HUDSON, BAFFIN AND DAWSON), designed to meet the requirements below.

Winch Requirements

The winch is primarily to be used to tow deep-ocean survey instrumentation such as SEA-MARC to acquire survey information to 6500 mm water depths. Secondary requirement of this winch is to be capable of using it on station work with standard steel cable or special electrical/mechanical cable for piston coring to depths of 6500 mm with a 3000 lb. corer, or use in handling in BIO rock core drill in working depths of up to 3500 mm.

The cable types, their specifications and the lengths needed to carry out the above work are to be determined from discussions with the suggested list of contracts supplied. (attached)

Of primary importance is that the winch system be portable and easily moved from ship to ship as required. It is also anticipated that the winch system will be self contained probably with its own diesel powered prime mover, be capable of having multiple or interchangeable drums to allow easy changing of cable and to have the drum(s) capable of being fitted with electrical slip rings.

The installation of the HUDSON, BAFFIN and DAWSON of the winch system should be investigated for use in both the station and towing modes and the effect on the ship's stability, the location(s) proposed, the strengthening of ship structure to mount unit required and the method of leading cable over side specified.

A preliminary design of the installation should be produced outlining the major problems and possible solutions to overcome them.

The entire winch system specified shall be capable of operating satisfactorily for long periods on the open deck of ships in severe conditions imposed by use at sea. The winch must be suitably martitized to withstand the corrosive environment and the possibility of water immersion resulting from wave action on deck. Note also that fluctuating line loads are present due to transient conditions caused by ship's motion, cable elasticity as well as other forces inherent in a particular operation.

Statement of Work

The contractor shall conduct a thorough investigation of winch designs and configurations capable of meeting the requirements specified. It is also his responsibility to take into consideration the particular operational requirements of the intended applications. A source list of present users of towed systems, corers, and drills is included for further consultation.

The final report to be submitted shall include.

1. A recommendation on the type of winch required. The recommendation should be supported by a discussion of the types and arrangements considered.
2. A technical specification covering the design, manufacture, shop testing and delivery of the proposed winch. Proceed with specification after approval of Part 1.
3. A cost estimate of the proposed winch.
4. A list of proposed suppliers.
5. A preliminary design of the installation(s) on HUDSON, BAFFIN and DAWSON outlining major installation problems and possible solutions to overcome them and a budgetary cost estimate of each.

I. References on Deep Towing

1. Dr. William Ryan
Lamont-Doherty Geological Observatory
Columbia University
Pallisades, New York
U.S.A. 10964 (present owner)

Tel. (914) 359-2900
2. J. Kosalas
International Submarine Technology Ltd.
2733-152 Avenue, N.E.
Redmond, Washington
U.S.A. 98052
3. D.E. Boegeman
Engineering Section Head
Deep Tow Project
University of California, San Diego
Marine Physical Laboratory of the Scripps
Institution of Oceanography
San Diego, California
U.S.A. 82132

Tel. (714) 294-3650

II. References on Station Work Requirements

1. Dr. P. Ryall
Department of Geology
Dalhousie University
Halifax, Nova Scotia

Tel. 424-3465
2. A.H. Driscoll
Director, Coring Facilities
Graduate School of Oceanography
Ocean Engineering, Coring Facilities
University of Rhode Island
Kingston, Rhode Island
U.S.A. 02881

Tel. (401) 294-2863

III. References on Installations on BIO Ships

1. G. Totten
Ships Division
Bedford Institute of Oceanography
Dartmouth, Nova Scotia

Tel. (902) 426-7292